

<b>Subject:</b>  <b>INSTRUCTIONS FOR LABELS INCLUDED WITH REPLACEMENT HIGH VOLTAGE BATTERY PACKS</b>	<b>Service Alert No.: SA-049/25</b>
	<b>Last Issued : 10/16/2025</b>

## BULLETIN NOTES

### APPLICABLE MODEL(S)/VINS

2026 CX-90 (All)  
2026 CX-70 (All)  
2026 CX-50 Hybrid

## DESCRIPTION

Replacement battery packs for High Voltage systems are supplied with an additional label that matches the one attached to the service battery pack (refer to the sample High Voltage Battery Label image for reference). When replacing the battery pack in a 2026 or later model that has a similar label at the base of the left B-pillar, replace the label with the new one included in the service parts battery pack.

**ATTENTION:** The application of high-voltage battery labels is a regulatory requirement at both the federal and certain state levels, effective for 2026 and later model years. If you are replacing the battery pack on a 2025 model year vehicle or earlier that does not have a label at the base of the left B-pillar, applying a new label is not required, and the label may be discarded.

### CAUTION - PHEV Battery Replacement:

After replacing a PHEV battery pack, ensure that the Battery Energy Control Module (BECM) is updated to the latest software level.

For guidance, refer to the following instructional video or scan the QR Code: High Voltage Battery Removal and Replacement Steps

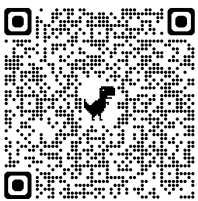

**CONSUMER NOTICE:** The information and instructions in this bulletin are intended for use by skilled technicians. Mazda technicians utilize the proper tools/ equipment and take training to correctly and safely maintain Mazda vehicles. These instructions should not be performed by "do-it-yourselfers." Customers should not assume this bulletin applies to their vehicle or that their vehicle will develop the described concern. To determine if the information applies, customers should contact their nearest authorized Mazda dealership. Mazda North American Operations reserves the right to alter the specifications and contents of this bulletin without obligation or advance notice. All rights reserved. No part of this bulletin may be reproduced in any form or by any means, electronic or mechanical---including photocopying and recording and the use of any kind of information storage and retrieval system ---without permission in writing.

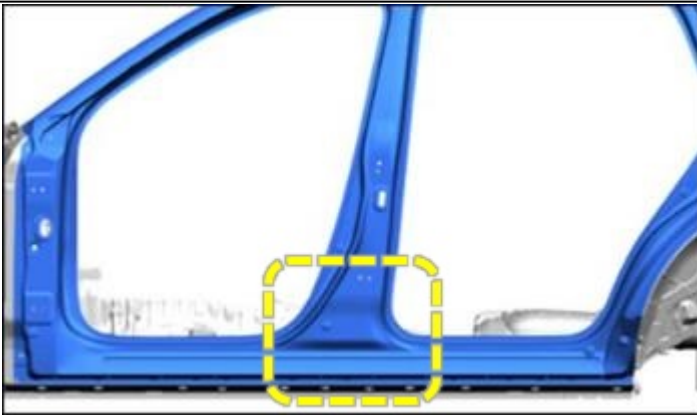
**Reference Images****Sample of High Voltage Battery Label****Left Side B-Pillar****REPAIR PROCEDURE****Label Application:**

When replacing a High Voltage Battery: refer to the Label Application Process included in the **"HIGH VOLTAGE BATTERY REMOVAL/INSTALLATION"** or **"M Hybrid Boost BATTERY REMOVAL/INSTALLATION"** procedures in the Workshop Manual for the applicable models.

In addition to the procedures outlined in the Workshop Manual, please follow these additional steps when removing an existing label to help simplify the application of the new one:

1. Apply masking tape to two sides of the old label (see Label Location example).
2. Use a heat gun to gently warm the original label before peeling it off from the B-pillar to avoid any paint damage.

**CONSUMER NOTICE:** The information and instructions in this bulletin are intended for use by skilled technicians. Mazda technicians utilize the proper tools/ equipment and take training to correctly and safely maintain Mazda vehicles. These instructions should not be performed by "do-it-yourselfers." Customers should not assume this bulletin applies to their vehicle or that their vehicle will develop the described concern. To determine if the information applies, customers should contact their nearest authorized Mazda dealership. Mazda North American Operations reserves the right to alter the specifications and contents of this bulletin without obligation or advance notice. All rights reserved. No part of this bulletin may be reproduced in any form or by any means, electronic or mechanical---including photocopying and recording and the use of any kind of information storage and retrieval system ---without permission in writing.

3. Clean and degrease the area after peeling off the label.
4. Attach the new label received with the new battery pack along the masking tape.



**Missing Label or B-Pillar Damage:**

A process for obtaining replacement labels for situations such as missing label or damage to the B-pillar that requires replacement of the original label without the need to replace the battery pack is under development. Please refer to this Service Alert for future updates on this process.

**PARTS INFORMATION**

Parts Number	Description	Qty.	Notes
****-30-210*	PACK,BATTERY	1	for PHEV
****-30-20X*	PACK,BATTERY	1	for CX-50 HYBRID
****-67-ZBX*	BATTERY-PACK	1	for MHEV48

**WARRANTY INFORMATION**

**ATTENTION:** A photograph of the old label and the new label with the repair order in the background showing VIN are required to be included on the warranty claim for processing.

**CONSUMER NOTICE:** The information and instructions in this bulletin are intended for use by skilled technicians. Mazda technicians utilize the proper tools/ equipment and take training to correctly and safely maintain Mazda vehicles. These instructions should not be performed by "do-it-yourselfers." Customers should not assume this bulletin applies to their vehicle or that their vehicle will develop the described concern. To determine if the information applies, customers should contact their nearest authorized Mazda dealership. Mazda North American Operations reserves the right to alter the specifications and contents of this bulletin without obligation or advance notice. All rights reserved. No part of this bulletin may be reproduced in any form or by any means, electronic or mechanical--including photocopying and recording and the use of any kind of information storage and retrieval system ---without permission in writing.