

October 31, 2025

Version 1

Product Update: 2024 ZDX Rear Electric Drive Module (eAxle) Replacement

APPLIES TO

Year	Model	Trim Level	VIN Range
2024	ZDX	A-Spec, Type S	Check the iN VIN status for eligibility.

BACKGROUND

During the manufacturing process of the rear electric drive module (eAxle), the mounting nut may have been improperly torqued or misaligned, potentially resulting in a loose or cross-threaded condition. This condition could lead to fluid leakage from the rear drive module, accompanied by a whine noise, possibly leading to a loss of driving force.

CLIENT NOTIFICATION

Owners of affected vehicles will be sent a notification of this product update.

Do an iN VIN status inquiry to make sure the vehicle is shown as eligible.

Some vehicles affected by this campaign may be in your new or used vehicle inventory. Repair these vehicles before they are sold.

CORRECTIVE ACTION

Replace the rear electric drive (eAxle) module assembly.

WARRANTY CLAIM INFORMATION

A-Spec

Operation Number	Description	Flat Rate Time	Defect Code	Symptom Code	Template ID	Failed Part Number
1181HS	Replace Rear Electric Drive Module eAxle (includes alignment)	4.6hr	6WY000	WMX00	B25038A	24066926

Type S

1181HR	Replace Rear Electric Drive Module eAxle with Air Suspension (includes alignment)	6.8hr	6WY000	WMX00	B25038B	24066925
--------	---	-------	--------	-------	---------	----------

CLIENT INFORMATION: The information in this bulletin is intended for use only by skilled technicians who have the proper tools, equipment, and training to correctly and safely maintain your vehicle. These procedures should not be attempted by “do-it-yourselfers,” and you should not assume this bulletin applies to your vehicle, or that your vehicle has the condition described. To determine whether this information applies, contact an authorized Acura automobile dealer.

PARTS INFORMATION

NOTE: Certain parts for this product update are controlled. Acura expects a very small number of vehicles that will require parts replacement.

* Create a Techline contact and call Techline to order part.

** Order part through normal controlled parts ordering.

Part Name	Part Number	Quantity
Rear, Electric Drive Module (eAxle) 2WD	24066917RM *	1
Rear, Electric Drive Module (eAxle) AWD	24066925RM *	1
Bolt, Rear Drive Motor Mount (M14 x 2 x 113)	11603529	2
Bolt, Rear Drive Motor Mount (M12 x 1.75 x 115.9)	11589282	1
Bolt, Rear Drive Motor Mount (M12 x 1.75 x 60)	11609605	3
Bolt, Rear Stabilizer Shaft Link	11588744	2
Bolt, Rear Shock Absorber	11589358	2
Bolt, Rear Suspension Trailing Arm	11609606	2
Bolt, Rear Suspension Inner Control Arm (Upper) (M14 x 2.0 x 75)	11610884	2
Bolt, Rear Cradle Bracket (M12 x 1.75 x 45.8)	11519538	6
Bolt, Rear Suspension Cradle (M16 x 2 x 127)	11589375	4
Harness, RR Chassis (Type S)	85051529 **	1
Harness, RR Chassis (Non-Type S)	85051530 **	1

REQUIRED MATERIALS

Part Name	Part Number	Quantity
BEVF Type PZ	08200-9025	4 quarts
LL Coolant (Type-PZ)	OL999-9033	4 gallons

TOOL INFORMATION

Tool Name	Tool Number	Quantity
Propulsion, System Lift Equivalent	KLS6227500	1
Air Suspension Charger	07AAK-TYBA102	1
Engine Lift Bracket	07-J-36857	2
Engine Support Fixture Adapter Bolts	07-J-52059	3
Transmission Fluid Fill Pan Adapter	07-DT-47784	1
Cooling System Adapter	07-GE-46143-A	1
Vac-N-Fill Coolant Refill Tool or equivalent	07-GE-47716	1

REPAIR PROCEDURE

DANGER

Always perform the High Voltage Disabling procedure prior to servicing any High Voltage component or connection. Personal Protection Equipment (PPE) and proper procedures must be followed. Failure to follow the procedures will result in serious injury or death.

NOTE: Review all [High Voltage Safety](#) information and the Job Aid: [High-Voltage Battery Storage and Handling](#) prior to starting repairs.

The High Voltage Disabling procedure includes the following steps:

- Identify how to disable high voltage.
- Identify how to test for the presence of high voltage.
- Identify conditions under which a high voltage is always present and Personal Protection Equipment (PPE) and proper procedures must be followed.

Before working on any high voltage system, be sure to wear the following Personal Protection Equipment:

- Safety glasses with appropriate side shields when within 15 meters (50 feet) of the vehicle, either indoors or outdoors.
- Certified and up-to-date Class "0" Insulation gloves rated at 1000V with leather protectors.
- Visually and functionally inspect the gloves before use. Wear insulation gloves with leather protectors at all times when working with the high voltage battery assembly, whether the system is energized or not.

Type S Only:

CAUTION

DO NOT remove the Automatic Level Control System components, the system is pressurized. Disconnecting a pressurized air line that is connected to an Automatic Level Control System component can cause damage to components and/or result in injury.

1. Before lifting the vehicle set the suspension to service mode.

To enter service mode use the vehicle's infotainment screen:

Settings > Vehicle > Suspension > Service Mode, move the slider to the right to activate **Service Mode**

2. Connect the Multiple Diagnostic Interface 2 (**MDI2**) and use the Honda Techline Connect (TLC) application to deflate the rear left and right air springs.

Follow the path to deflate the air springs:

Control Function > Automatic Level Control Module > Short Term Deflate > Select Enter and Repeat

Rear Suspension Cradle Removal

1. Follow **steps 1 and 2:** [Rear Suspension Cradle Removal and Installation](#)
2. Disconnect the 12 volt battery negative cable. [Battery Negative Cable Disconnection and Connection](#)
3. Raise and support the vehicle. [Lifting and Jacking the Vehicle](#)
4. Remove the rear wheel and tire assemblies. [Tire and Wheel Removal and Installation](#)
5. Remove the underbody rear air deflectors:
 1. [Underbody Rear Air Rear Deflector Replacement - Rear](#)
 2. [Underbody Rear Air Rear Deflector Replacement - Middle](#)
 3. [Underbody Rear Air Rear Deflector Replacement - Front](#)
6. Release both [Rear Wheelhouse Liners](#).
7. Drain the coolant from the rear drive motor:

Release the retainer [1] and remove the rear electric drive coolant hose [3]. Drain the coolant in a suitable container. Disconnect the wiring harness connector [2] and unclip the wiring harness retainers [4].

NOTE: Disconnect the coolant hoses and electrical connectors at the rear electric drive module. Move the hoses and electrical connectors out of the way to prepare the rear electric drive for removal.

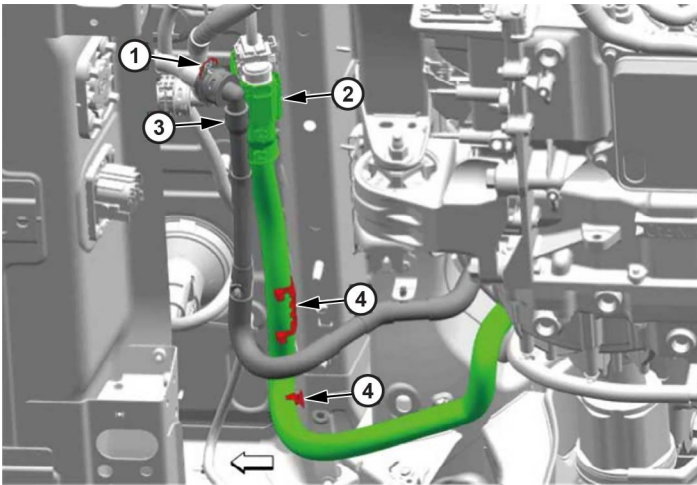

8. Release the retainer clip [1] and disconnect the drive motor control module cooling outlet hose [2]. Remove the high voltage battery heater coolant hose retainer.

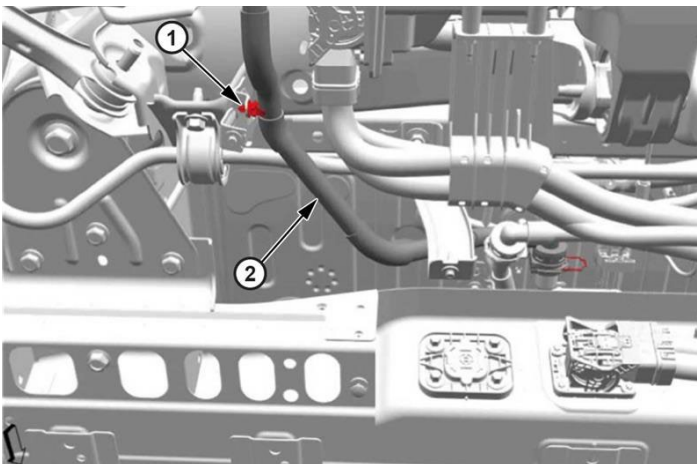

9. Release the retainer [1] and disconnect the rear drive motor control module cooling outlet hose [2]. Remove the high voltage battery heater coolant hose retainer clip [3]. Drain any remaining coolant in a suitable container.

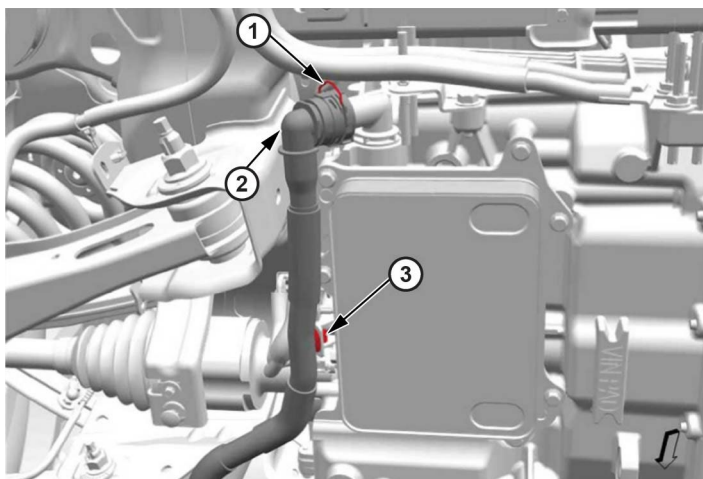

10. Disconnect the left and right electrical connector [1] and clip [2] at the rear parking brake actuator.

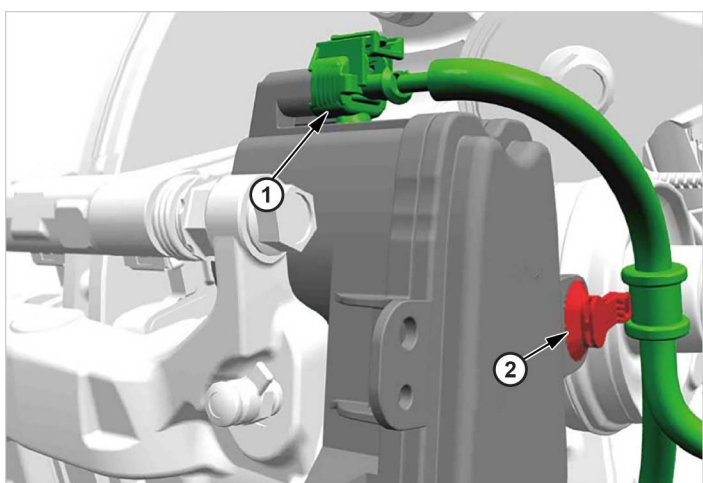

11. Remove the left and right rear brake caliper [1] guide pin bolts [2].

NOTE:

- **DO NOT** remove the rear brake caliper bracket bolts.
- **DO NOT** use air tools to remove the guide pin bolts. Use hand tools only.
- **DO NOT** disconnect the rear brake hose.

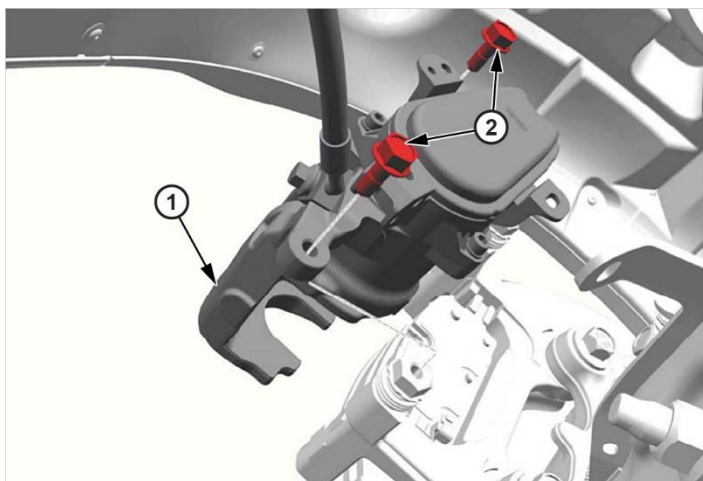

12. Remove both rear brake calipers and support them using mechanic's wire or equivalent.

NOTICE

Failure to support the brake calipers with mechanic wire or an equivalent may cause damage to the brake hose and brake fluid to leak.

13. Support the suspension control arm with a hydraulic jack or equivalent. Remove the left and right rear shock absorber bolt [1] and nut [2]. Retain the nuts, discard the bolts.

NOTE: The bolts are a must replace part.

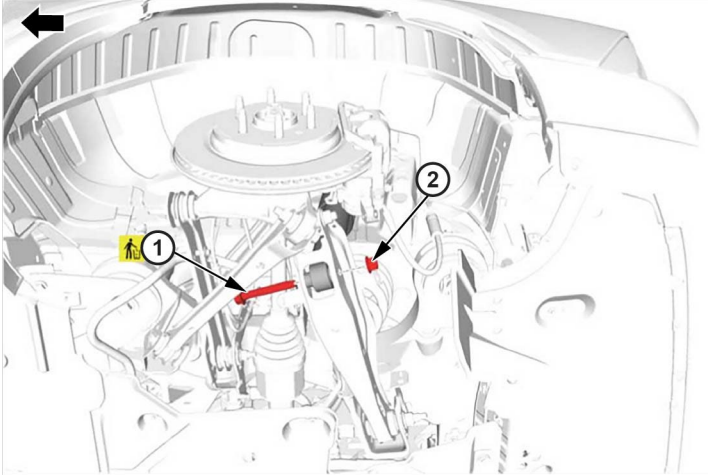

14. **Type S Only:** Secure the left and right air spring suspension to the vehicle using tie down straps [1]. Do not trap the brake hose or the air suspension lines.

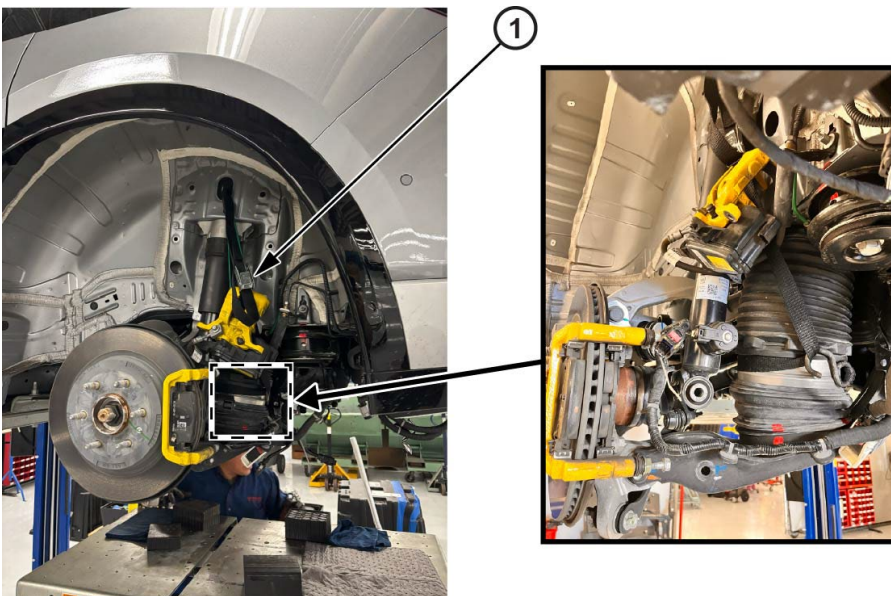

15. Follow steps 16 to 29: [Rear Suspension Cradle Removal and Installation](#)

16. Remove the body ground bolts [3] first, then remove the bolts and wiring harness brackets [4]. Leave the wire harness [2] on the retainers [1]. Reposition the body ground strap away from the rear electric drive module.

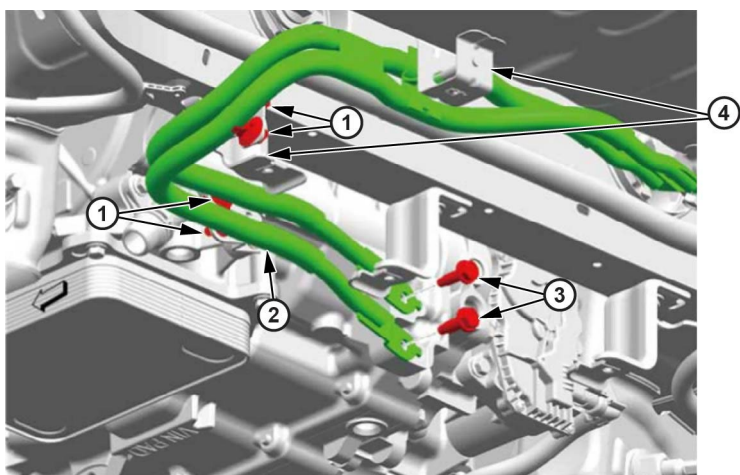

17. Follow steps **33 to 41**. [Rear Suspension Cradle Removal and Installation](#)

Rear Electric Drive Transmission Module Removal.

1. Follow **steps 1 to 6**: Separate the rear suspension cradle from the rear electric drive transmission module. [Rear Electric Drive Transmission Module Removal Procedure](#)

Type S equipped with Air Leveling Position Sensor, proceed with step 2.

Non-Type S continue to step 3.

2. Remove the rear headlamp leveling sensor bolt [1] and nut [2]. [Rear Suspension 2 or 4 Corner Air Leveling Position Sensor](#)

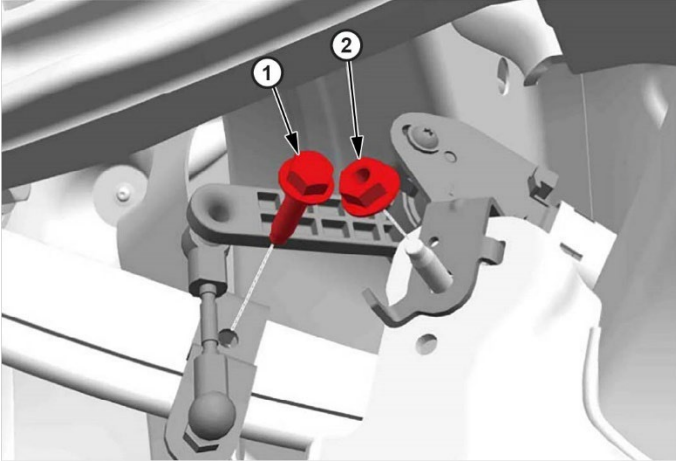

3. Remove the upper bolt [1] and upper nut [2] from the rear suspension trailing arm [3]. Repeat the procedure for both sides. Retain the nuts, discard the bolts.

NOTE: The bolts are a must replace part.

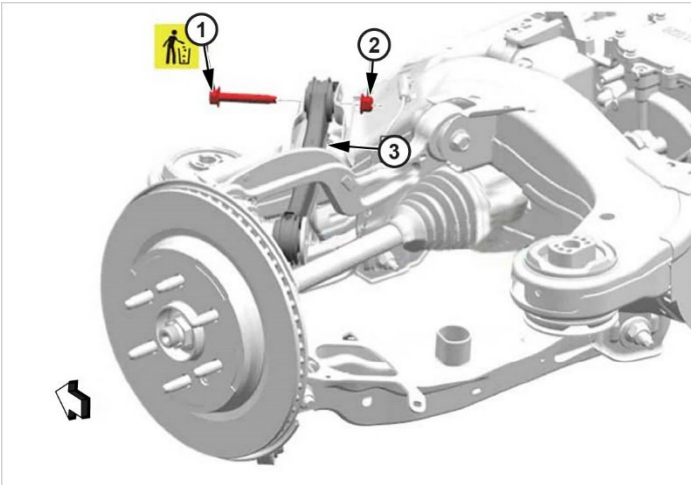

4. Remove the rear suspension upper control arm inner nut [1] and bolt [2]. Repeat the procedure for both sides. Retain the nuts, discard the bolts

NOTE: The bolts are a must replace part.

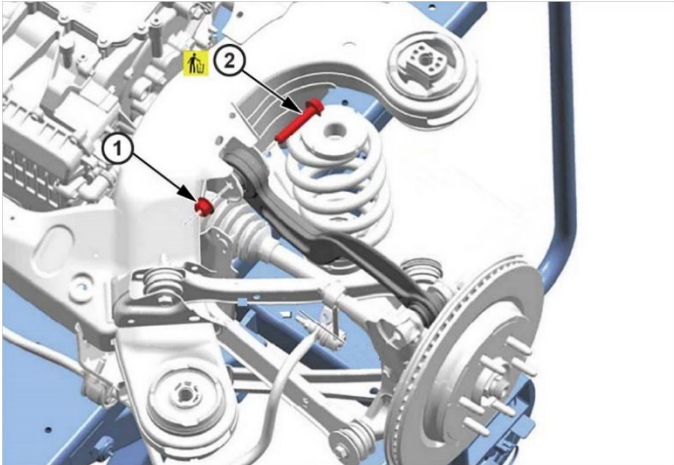

5. Follow **steps 13 to 17:** [Rear Electric Drive Transmission Module Removal Procedure](#)
6. Using the overhead engine hoist carefully separate the rear suspension cradle from the rear electric drive module. Set the rear suspension cradle on a level surface.



7. Follow **steps 19 to 23:** [Rear Electric Drive Transmission Module Removal Procedure](#)
8. Attach the engine lift bracket and support fixture adapter bolts to the **old** rear electric drive module. Use the overhead hoist and remove the rear electronic drive module off of the propulsion lift system. Set the module on flat surface, use wood blocks to level the module.



9. Transfer the engine lift bracket and support fixture adapter bolts to the **NEW** rear electric drive module, use the overhead hoist and place the **NEW** rear electronic drive module onto the propulsion lift system.

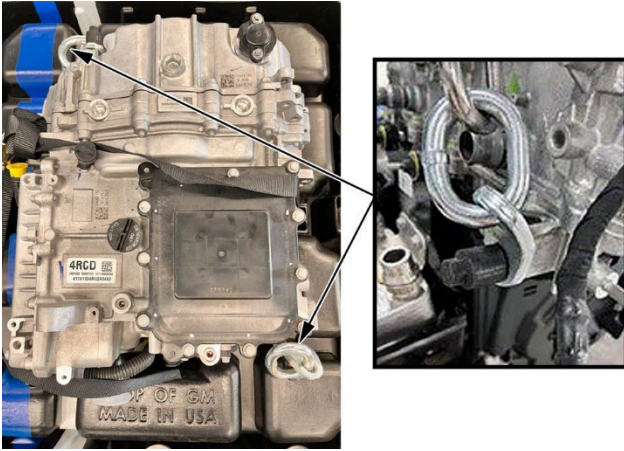

Remove and Transfer Components to the New Rear Drive Module.

1. Install a **new** rear chassis harness [1] to the **NEW** rear electric drive module.

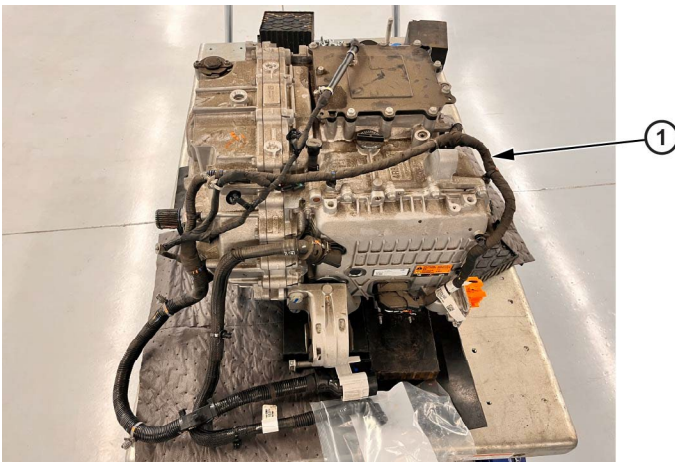
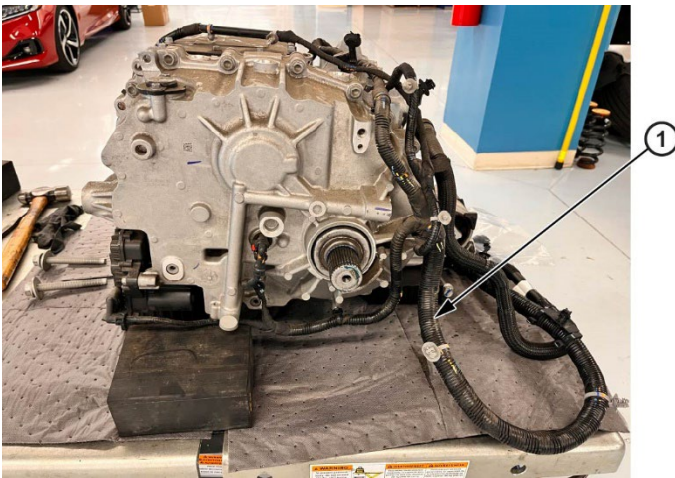

2. Transfer the rear electric drive coolant hose [1] to the **NEW** rear electric drive module.

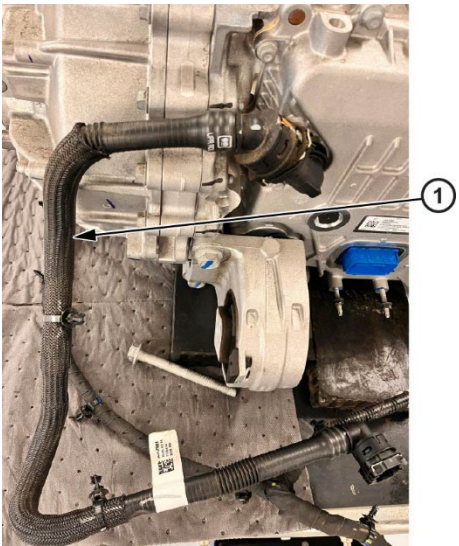

3. Transfer the rear motor mount [2] to the **NEW** rear electric drive module. Use new motor mount bolts [1] and follow the steps for torquing:
 1. Torque all bolts to the specified torque **100 N·m (74 lb-ft)**.
 2. Tighten the bolts an additional **75° degrees**.

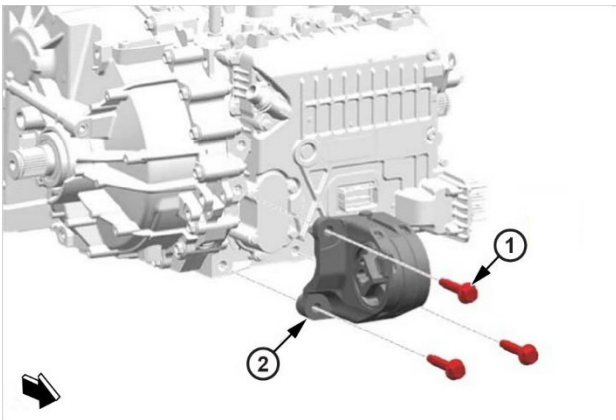

4. Attach the engine lift bracket and support fixture adapter bolts to the **old** rear electric drive module. Place the defective drive module core into the crate with all original shipping materials for return.

INSTALLATION PROCEDURE

1. Follow **steps 1 to 24** of the *Installation Procedure* to Install the rear suspension cradle onto the rear electric drive transmission module. [Rear Electric Drive Transmission Module Replacement](#)

NOTE: The new electric drive module will have the output shaft O-rings and retainer clips installed.

NOTICE

This vehicle is equipped with torque-to-yield or single use fasteners. When instructed, install **NEW** torque-to-yield or single use fastener when installing components. Failure to replace torque-to-yield or single use fastener could cause damage to the vehicle or its components.

Type S equipped with **Air Leveling Position Sensor**, proceed with step 2.

Non-Type S, continue to step 3.

2. Install the rear headlamp leveling sensor bolt [1] and nut [2]. [Rear Suspension 2 or 4 Corner Air Leveling Position Sensor](#)

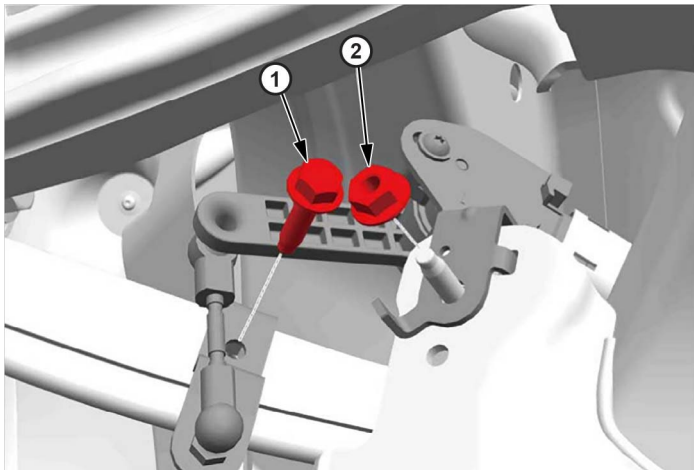

3. Follow **steps 1 to 29** of the *Installation Procedure* to install the rear cradle to the vehicle. [Rear Suspension Cradle Removal and Installation](#)

NOTICE

This vehicle is equipped with torque-to-yield or single use fasteners. When instructed, install **NEW** torque-to-yield or single use fastener when installing components. Failure to replace torque-to-yield or single use fastener could cause damage to the vehicle or its components.

After step 29, follow this step:

4. Reinstall the left and right rear brake calipers [1] and guide pins [2]. Torque the guide pins to **40 N·m (30 lb-ft)**.

NOTE: **DO NOT** use any air tools to install the guide pins. Use hand tools **only**.

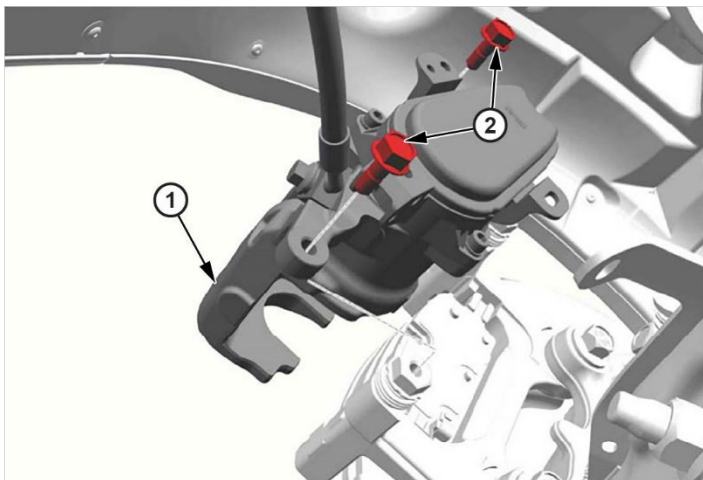

5. Follow **Installation Procedure steps 32 to 39**. [Rear Suspension Cradle Removal and Installation](#)

After step 39, follow these steps:

6. Fill the rear electric drive with new transmission fluid to the proper level. [Transmission Fluid Drain and Fill](#)
7. Enable the high voltage system. [High Voltage Enabling](#)
8. Connect the 12 volt battery negative cable. [Battery Negative Cable Disconnection and Connection](#)
9. Fill the drive motor battery cooling system to the proper level. [Drive Motor Battery Cooling System Draining and Filling](#)

10. Type S Only:

Perform the following **ONLY** if the air supply reservoir tank is empty or needs slight filling.

1. Remove the automatic level control air supply reservoir coupling cap.
 2. Install air suspension charger (P/N 07AAK-TYBA102) to the automatic level control air supply reservoir air valve and set the regulator on the nitrogen tank to **15 Bar (217.55 PSI)**.
 3. Open the air suspension charger valve on the pressure gauge to fill the automatic level control air supply reservoir.
 4. Use nitrogen to fill the automatic level control air supply reservoir to **15 Bar (217.55 PSI)**.
 5. Close the air suspension charger valve on the pressure gauge and remove from the automatic level control air supply reservoir.
 6. Install the automatic level control air supply reservoir coupling cap and tighten **2 N·m (18 lb in)**.
- 11. Type S Only:**
1. Partially lower the vehicle, **DO NOT** let the wheels touch the ground.
 2. Connect the **MDI2** and use Honda Techline Connect (TLC) to verify the automatic level control air supply tank pressure is at **15 Bar (217.55 PSI)**.
 3. Use short-term inflate to increase pressure to the rear air springs:

- **FRONT: 7 Bar (101.526 PSI)**
- **REAR: 7 Bar (101.526 PSI)**

- 12. Type S Only:** Perform [Automatic Level Control Trim Height Learn](#).

NOTE:

- The battery voltage range must be **9-15.5 volts** with the ignition set to **ON** and the engine **OFF**.
- Vehicle ride height must be within specification to complete procedure successfully. Refer to [Trim Height Inspection](#) and [Trim Height Specification](#).

13. Measure and adjust the wheel alignment. [Wheel Alignment Measure](#)
14. Verify proper operation of the transmission.
15. Inspect for coolant leaks.
16. Inspect for transmission fluid leaks.