

Title: 12 Volt Maintainer Install

Applicability: All 2020 and newer Karma vehicles

Market Region: All

As per the owner manual in “Vehicle Storage” section Connect an approved Absorbed Glass Mat (AGM) compatible battery maintainer to prevent it from discharging. In order to best care for the 12Volt battery in a vehicle that sees extended storage, Karma recommends the installation and use of a battery maintainer. The preferred charger is a “NOCO genius 10.”

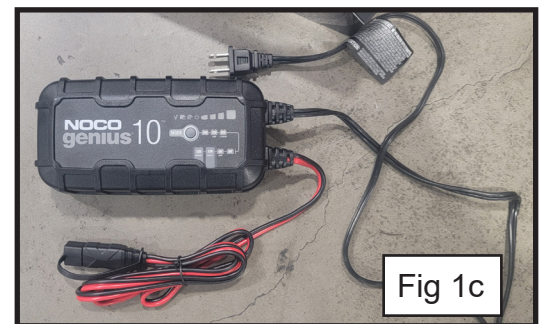
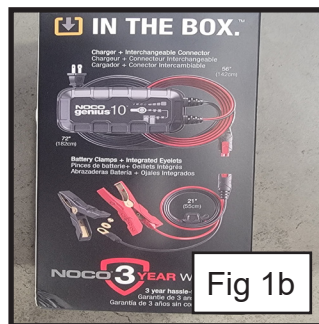
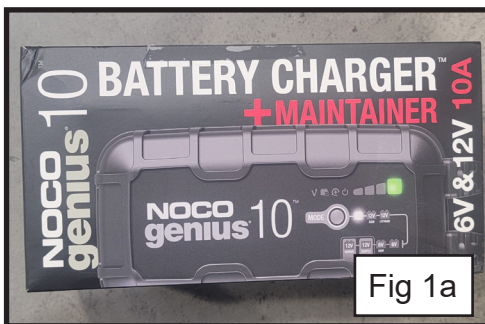

Prepare the Connectors: the alligator clips will need to be removed to install the pigtail on the battery. This is done using a 3mm Allen key. (Fig2a, 2b, 2c, 2d)

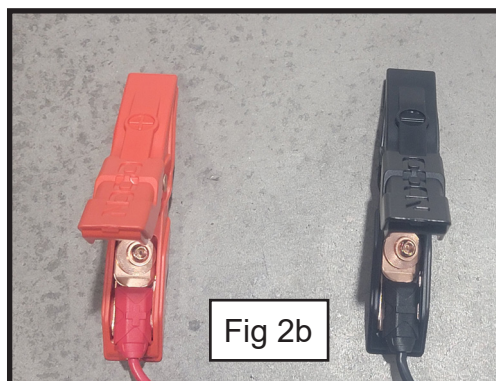

The eyelet terminals are now ready for install on to the 12 V battery. (Fig 3a, 3b)

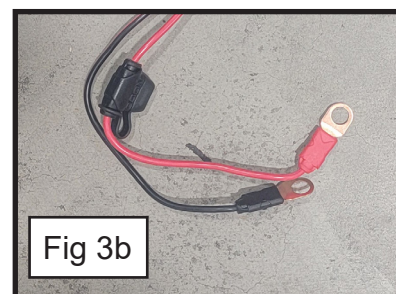
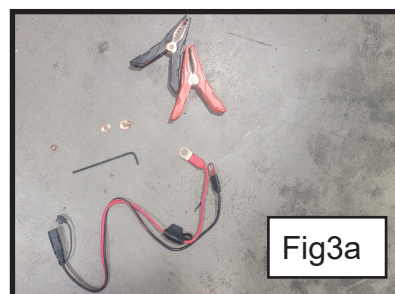

Karma Automotive Bulletins and service documents are intended for use by experienced and trained Technicians. If you lack the skills, tools, equipment and a suitable workshop for any procedure described in this document, we suggest you leave such repairs to a Karma retailer and service provider. See your service provider for advice on whether your vehicle may benefit from the information contained within this document. The information contained in the Karma Bulletin is accurate at the date of publication. However, Karma Automotive regularly updates technical information. Please check with your Karma Automotive Retailer and Karma Automotive service provider that the bulletin you intend to use contains the latest available information.

Title: 12 Volt Maintainer Install

Applicability: All 2020 and newer Karma vehicles

Market Region: All

To provide access to the 12V battery.

1. Rack the vehicle. Loosen the wheel with the appropriate 22mm socket and a breaker bar (Fig. 4). Lift to a comfortable height to remove the wheel.

(Reassembly torque is 220Nm.) Remove the wheel well arch liner.



2. Remove the 10 (ten clips on the liner) begin with the front three body clips, of the wheel liner. (Fig.5a, Fig. 5b).

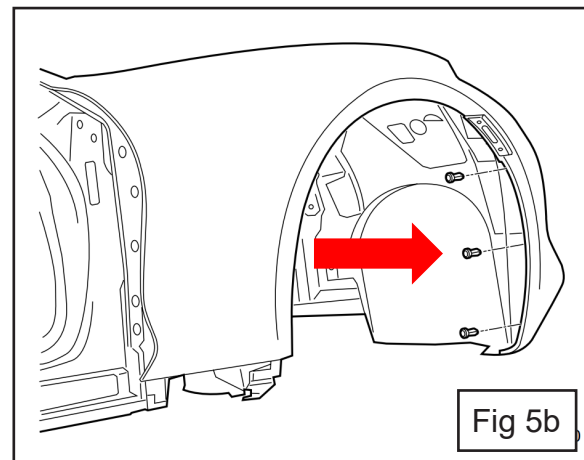
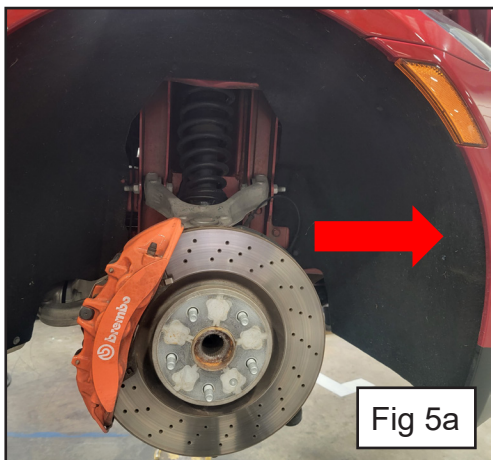

Karma Automotive Bulletins and service documents are intended for use by experienced and trained Technicians. If you lack the skills, tools, equipment and a suitable workshop for any procedure described in this document, we suggest you leave such repairs to a Karma retailer and service provider. See your service provider for advice on whether your vehicle may benefit from the information contained within this document. The information contained in the Karma Bulletin is accurate at the date of publication. However, Karma Automotive regularly updates technical information. Please check with your Karma Automotive Retailer and Karma Automotive service provider that the bulletin you intend to use contains the latest available information.

Title: 12 Volt Maintainer Install

Applicability: All 2020 and newer Karma vehicles

Market Region: All

Continue around the liner and remove the remaining body clips of the wheel liner (Fig.6a, Fig. 6b).

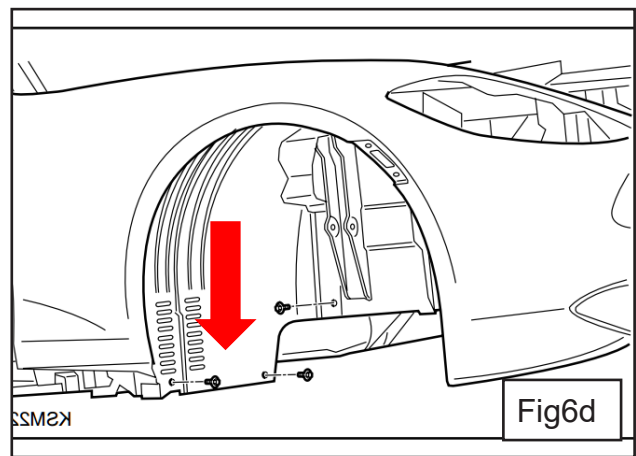
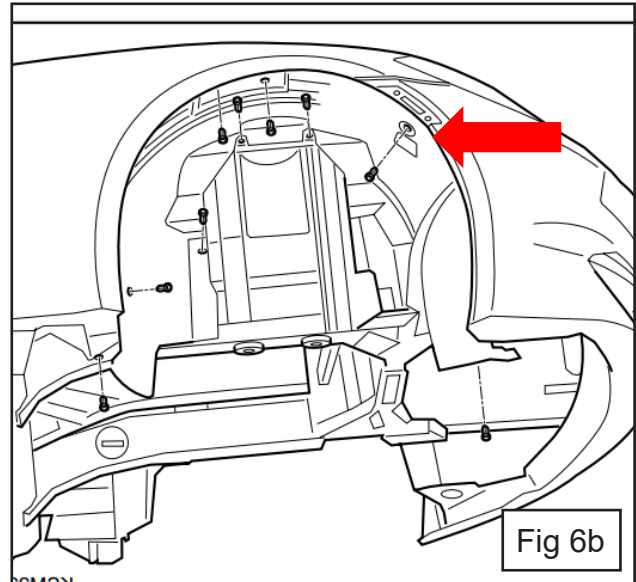
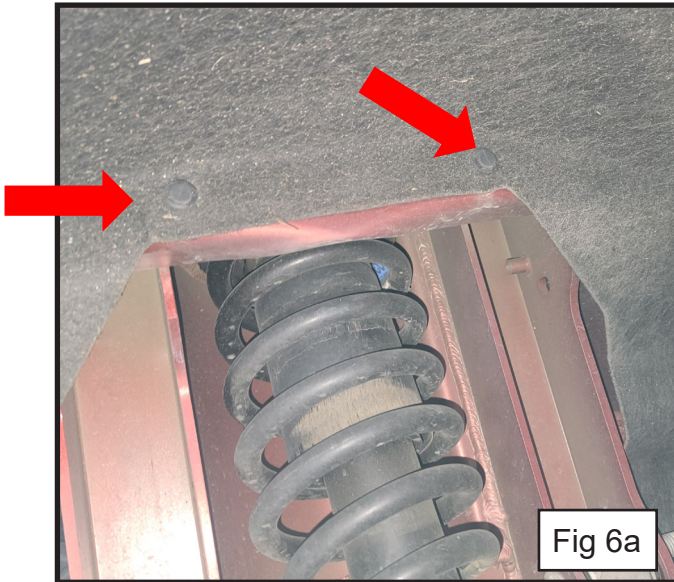

The aluminum wheel liner bracket will stay attached to the wheel liner upon removal (Fig. 6c and Fig.6d)

Karma Automotive Bulletins and service documents are intended for use by experienced and trained Technicians. If you lack the skills, tools, equipment and a suitable workshop for any procedure described in this document, we suggest you leave such repairs to a Karma retailer and service provider. See your service provider for advice on whether your vehicle may benefit from the information contained within this document. The information contained in the Karma Bulletin is accurate at the date of publication. However, Karma Automotive regularly updates technical information. Please check with your Karma Automotive Retailer and Karma Automotive service provider that the bulletin you intend to use contains the latest available information.

Title: 12 Volt Maintainer Install

Applicability: All 2020 and newer Karma vehicles

Market Region: All

3. Once the clips have been removed, pull down the wheel liner, remove, and set aside (Fig. 7a).

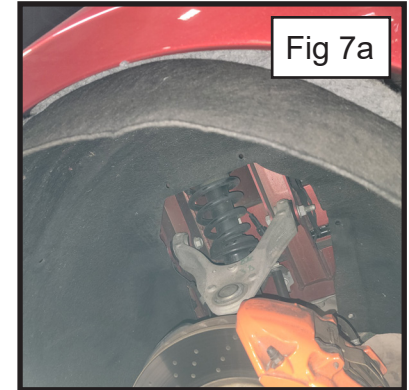

The Battery is visible now. Reach in and undo the tie down. Battery terminal bolts are 13mm.

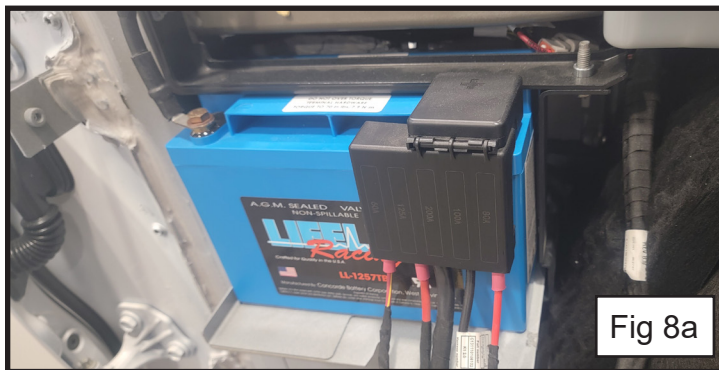

Shown here is the battery without a fender to aid in visualization (Fig 8a, 8b, 8c).



Karma Automotive Bulletins and service documents are intended for use by experienced and trained Technicians. If you lack the skills, tools, equipment and a suitable workshop for any procedure described in this document, we suggest you leave such repairs to a Karma retailer and service provider. See your service provider for advice on whether your vehicle may benefit from the information contained within this document. The information contained in the Karma Bulletin is accurate at the date of publication. However, Karma Automotive regularly updates technical information. Please check with your Karma Automotive Retailer and Karma Automotive service provider that the bulletin you intend to use contains the latest available information.

Title: 12 Volt Maintainer Install

Applicability: All 2020 and newer Karma vehicles

Market Region: All

Attach the pigtail ends to the appropriate terminal, red to red, black to black. (Fig 9a) Route the pig tail up by the reservoir to provide engine room access for the battery maintainer (Fig 9b).

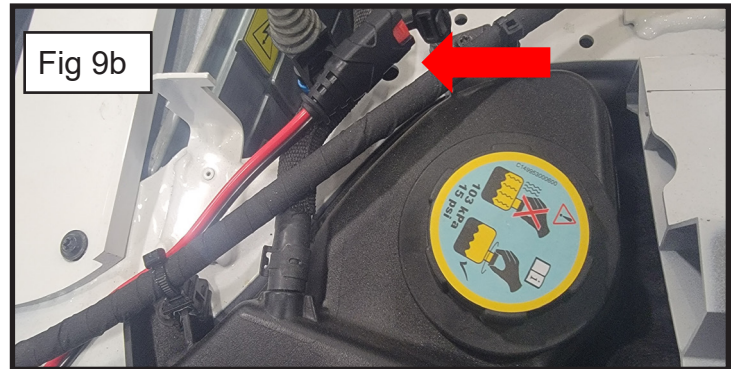
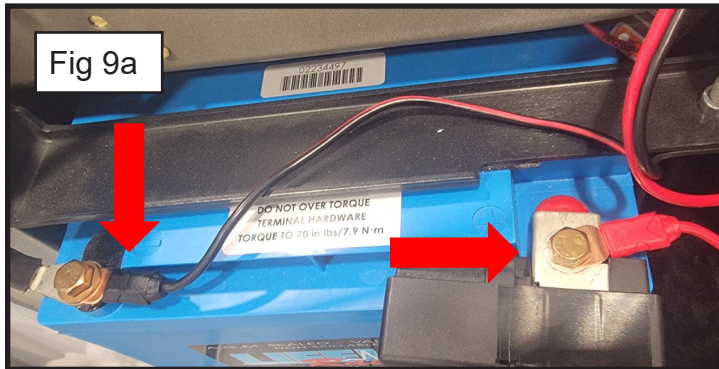

This battery maintainer is an aftermarket part install. As per the warranty guide under "ACCESSORIES COVERAGE", standard 12 month part warranty on the part for defects, from the install date regardless of mileage, unless otherwise specified in the documentation included with the accessory.