

Subject: A CREAKING NOISE COMING FROM THE ACTIVE DRIVING DISPLAY	Bulletin No.: 09-037/25
	Last Issued : 10/01/2025

BULLETIN NOTES

APPLICABLE MODEL(S)/VINS

2024-2026 CX-90 (All)
2025-2026 CX-70 (All)

DESCRIPTION

Some vehicles may exhibit a creaking noise from the area around the Active Driving Display on the dash pad while driving. This may be caused by the hole cover of the Active Driving Display and the internal components of the dash pad interfering with each other.

Customers having this concern should have their vehicle repaired using the following repair procedure.

REPAIR PROCEDURE

1. Verify the customer concern.
2. Prepare the non-woven fabric (black, thickness = 5mm) from the noise repair kit.
3. Cut three pieces of the non-woven fabric to a size of 80mm in length × 10mm in width.

NOTE: To make it easier to apply, process the cut non-woven fabric as shown in the diagram below (not to scale). At this time, cut off 20mm of only the non-woven fabric and remove it to create a peel-off margin using the release paper.

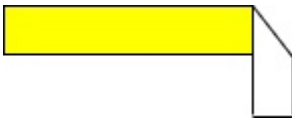

Processing Method (Yellow : Non-woven Fabric Side, White: Release Paper)

Top View



Side View



Release Paper on the Back Side

- a. Carefully cut only 20mm of the non-woven fabric in this section.



CONSUMER NOTICE: The information and instructions in this bulletin are intended for use by skilled technicians. Mazda technicians utilize the proper tools/ equipment and take training to correctly and safely maintain Mazda vehicles. These instructions should not be performed by "do-it-yourselfers." Customers should not assume this bulletin applies to their vehicle or that their vehicle will develop the described concern. To determine if the information applies, customers should contact their nearest authorized Mazda dealership. Mazda North American Operations reserves the right to alter the specifications and contents of this bulletin without obligation or advance notice. All rights reserved. No part of this bulletin may be reproduced in any form or by any means, electronic or mechanical--including photocopying and recording and the use of any kind of information storage and retrieval system ---without permission in writing.

b. Fold over the release paper as shown.



4. From the top surface of the dash pad, check the gap between the dash pad hole cover and the Heads-Up Display (HUD).

5. Insert the three pieces of non-woven fabric into the gap between the dash pad hole cover and the HUD, with the non-woven side facing upward.

NOTE: Parts removal is not necessary.

Front of the vehicle

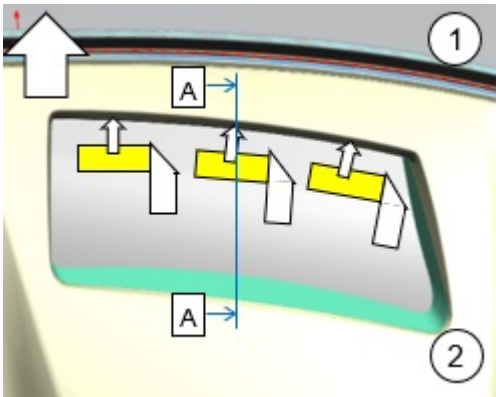

(1) Windshield

(2) Top Surface of the dash pad

Front of the vehicle

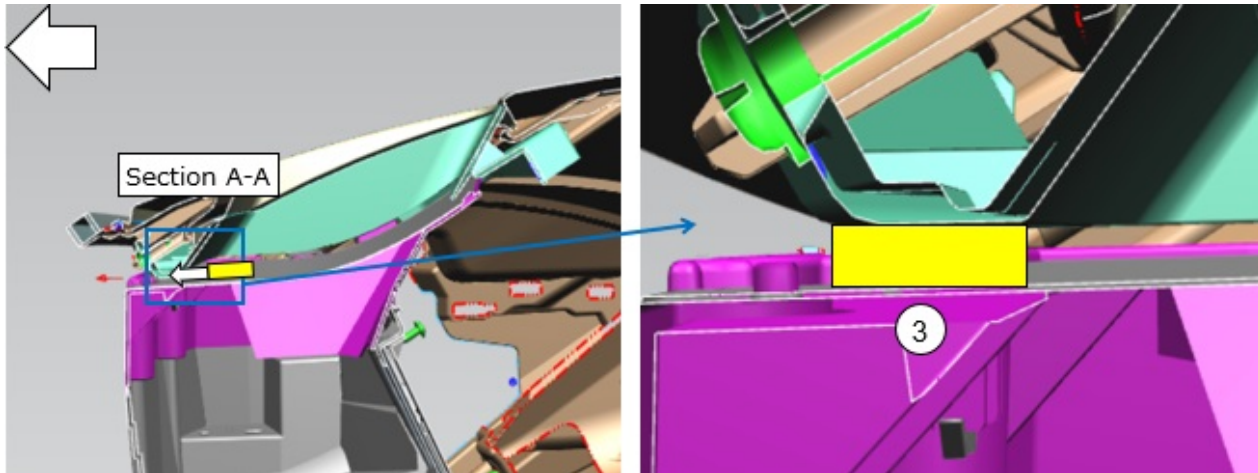

(3) Insert the non-woven fabric up to the corner of the hole c

Page 2 of 5

CONSUMER NOTICE: The information and instructions in this bulletin are intended for use by skilled technicians. Mazda technicians utilize the proper tools/ equipment and take training to correctly and safely maintain Mazda vehicles. These instructions should not be performed by "do-it-yourselfers." Customers should not assume this bulletin applies to their vehicle or that their vehicle will develop the described concern. To determine if the information applies, customers should contact their nearest authorized Mazda dealership. Mazda North American Operations reserves the right to alter the specifications and contents of this bulletin without obligation or advance notice. All rights reserved. No part of this bulletin may be reproduced in any form or by any means, electronic or mechanical---including photocopying and recording and the use of any kind of information storage and retrieval system ---without permission in writing.

over.

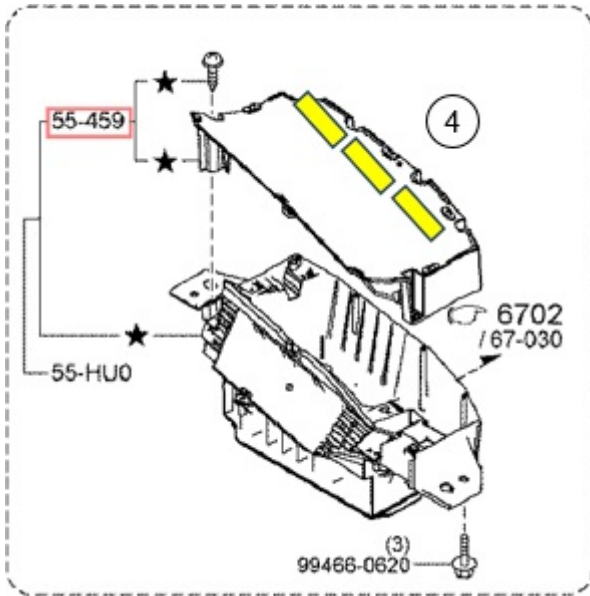

(4) Insert the non-woven fabric into this part of the HUD component.

6. After insertion, peel off the release paper and using a removal tool, press down on the non-woven fabric to prevent it from coming out of the gap.

CAUTION: DO NOT use metal tools to prevent scratches.



(5) Removal tool

(6) Pull out only the release paper.

CONSUMER NOTICE: The information and instructions in this bulletin are intended for use by skilled technicians. Mazda technicians utilize the proper tools/ equipment and take training to correctly and safely maintain Mazda vehicles. These instructions should not be performed by "do-it-yourselfers." Customers should not assume this bulletin applies to their vehicle or that their vehicle will develop the described concern. To determine if the information applies, customers should contact their nearest authorized Mazda dealership. Mazda North American Operations reserves the right to alter the specifications and contents of this bulletin without obligation or advance notice. All rights reserved. No part of this bulletin may be reproduced in any form or by any means, electronic or mechanical---including photocopying and recording and the use of any kind of information storage and retrieval system ---without permission in writing.

7. After peeling off the release paper, press the top surface of the dash pad downward to adhere the non-woven fabric.

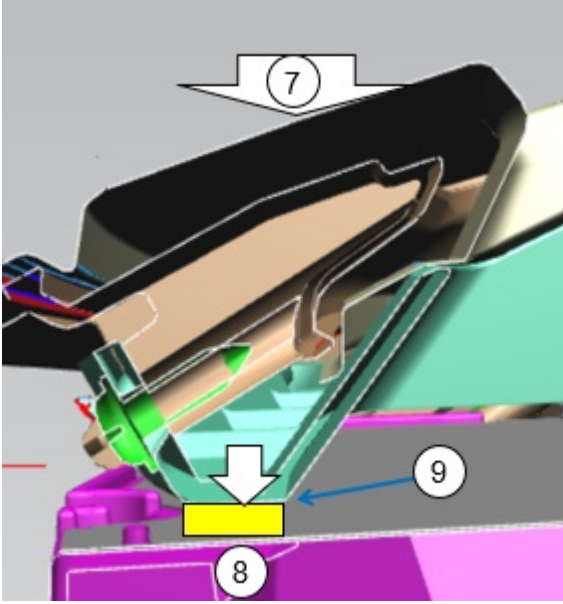

(7) Press Down

(8) Firmly Attach the non-woven fabric to the HUD

(9) Using a removal tool to press down is also an effective method

8. After completing the application, clean the surrounding area.

CAUTION: DO NOT use detergents or chemicals, as they may damage the surface coating. Use a soft, fine-textured cloth like glasses wipe to clean.

NOTE: If the tape is installed slightly off, it will not affect the display onto the windshield.



9. Verify the repair.

CONSUMER NOTICE: The information and instructions in this bulletin are intended for use by skilled technicians. Mazda technicians utilize the proper tools/ equipment and take training to correctly and safely maintain Mazda vehicles. These instructions should not be performed by "do-it-yourselfers." Customers should not assume this bulletin applies to their vehicle or that their vehicle will develop the described concern. To determine if the information applies, customers should contact their nearest authorized Mazda dealership. Mazda North American Operations reserves the right to alter the specifications and contents of this bulletin without obligation or advance notice. All rights reserved. No part of this bulletin may be reproduced in any form or by any means, electronic or mechanical---including photocopying and recording and the use of any kind of information storage and retrieval system ---without permission in writing.

PARTS INFORMATION

Parts Number	Description	Qty.	Notes
K001-W0-225	Int. Noise Repair Kit	1	Only use the non-woven sheet Size: 11.8 x 9.4 x 0.2 inch (300 x 240 x 5 mm) One sheet can repair 10 vehicles. (3 pieces of 80 x 10 mm) 240 x 30

WARRANTY INFORMATION**NOTE:**

- This warranty information applies only to verified customer complaints on vehicles eligible for warranty repair.
- This repair will be covered under Mazda's New Vehicle Limited Warranty term.
- Additional diagnostic time cannot be claimed for this repair.

Warranty Type	A
Symptom Code	82
Damage Code	98
Part Number Main Cause	***-55-HU0* (Specify the applicable ADD part number)
Quantity	0
Operation Number / Labor Hours:	XXX2XARX / 0.4 Hrs.

NOTE: Claim a portion of the Int. Noise Repair Kit (K001-W0-225) using 5555-25-003B.

CONSUMER NOTICE: The information and instructions in this bulletin are intended for use by skilled technicians. Mazda technicians utilize the proper tools/ equipment and take training to correctly and safely maintain Mazda vehicles. These instructions should not be performed by "do-it-yourselfers." Customers should not assume this bulletin applies to their vehicle or that their vehicle will develop the described concern. To determine if the information applies, customers should contact their nearest authorized Mazda dealership. Mazda North American Operations reserves the right to alter the specifications and contents of this bulletin without obligation or advance notice. All rights reserved. No part of this bulletin may be reproduced in any form or by any means, electronic or mechanical---including photocopying and recording and the use of any kind of information storage and retrieval system ---without permission in writing.