

# Technical Service Bulletin

<b>Topic</b>	Bentayga, Continental GT/C and Flying Spur 25 Model Year - Garage Door Opener Programming Procedure
<b>Market area</b>	Bentley: worldwide (2WBE),China 796 VW Import Comp. Ltd (Vico), Beijing (6796)
<b>Brand</b>	Bentley
<b>Transaction No.</b>	2077318/2
<b>Level</b>	EH
<b>Status</b>	Released for publishing
<b>Release date</b>	Sep 23, 2025

## New customer code

Object of complaint	Complaint type	Position
entire vehicle -> accessories -> owner's literature -> vehicle owner's manual	component, automotive fluids -> incomplete	

## Vehicle data

---

## Sales types

Type	MY	Brand	Designation	Engine code	Gearbox code	Final drive code
4V1*	2025	E		*	*	*
4V1*	2026	E		*	*	*
Z23*	2025	E		*	*	*
Z23*	2026	E		*	*	*
Z24*	2025	E		*	*	*
Z24*	2026	E		*	*	*
Z32*	2025	E		*	*	*
Z32*	2026	E		*	*	*
ZV1*	2025	E		*	*	*

## Documents

<b>Document name</b>
<a href="#">master.xml</a>

---

## Condition

Incomplete or missing garage door operation and programming instructions in owner's manual for 2025 Model year vehicles.

HomeLink instructional video is not current for all 2025 Model year .

## Technical Background

### 2025 Model year vehicles.

The owner's manual for the affected models does not include instructions on how to operate and program the vehicle integrated garage door opener. This feature allows owners to program their vehicle to open compatible garage doors, gates or automation systems directly from the interior controls. To address this, see the 'Measure' section of this TPI for the correct steps to programme and operate the garage door opener interior controls.

The HomeLink instructional video currently shows only a touchscreen interface to operate and programme the garage door opener. This is incorrect as an interior button located under the rear view mirror is used alongside the HMI screen to operate and programme the garage door opener.

Bentley specific videos via HomeLink will be updated shortly and made available soon. In the short term use the video link ⇒ <https://www.youtube.com/watch?v=TwAWf51IoRY>

To inform customers of the correct procedure to programme and operate their garage door opener.

## Production Solution

### Service

#### DANGER

Prior to programming, ensure that the area surrounding a device (e.g a garage door) is clear, as the device may operate during programming. Failure to do so could result in damage or personal injury. Always ensure that the path of any programmed device that opens or closes is kept clear, to avoid damage or personal injury. Do not use the programmable remote with any device that is not fitted with a 'safety stop and reverse' feature, or which does not meet all applicable safety standards.

#### NOTICE

After having programmed the garage door opener, check if the device needs to be synchronised with the receiver. Refer to the instructions from the garage door manufacturer. Programming the garage door opener remote transmitter can take up to 30 seconds. Make sure that the car and the batteries of the

remote control (hand-held transmitter) are fully charged.

**NOTICE**

The garage door opener can be programmed to configure up to three hand-held remotes, and can be used to operate devices such as garage doors, electric gates and outdoor lighting systems. Retain the original remote control for future programming procedures (ie., new vehicle purchase). If the vehicle is sold, the programmed buttons should be erased for security purposes. Setting up a new device is done by using the Bentley Infotainment system from inside the vehicle. The garage door opener is compatible with both fixed code and rolling code garage door systems.

**NOTICE**

The following instructions apply only to Bentley 2025 model year vehicles.

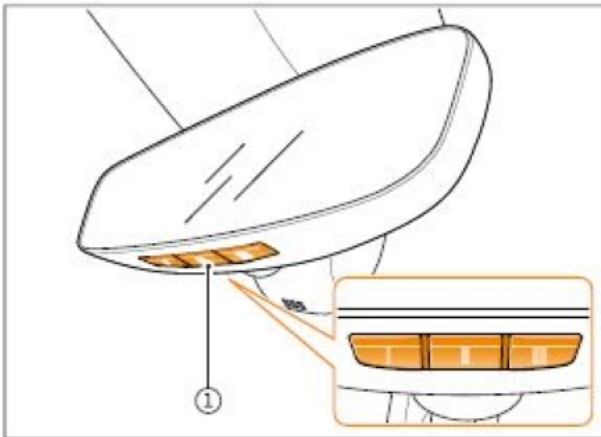

*Garage Door Opener*

The buttons for the garage door opener are located on the rear view mirror (1) and can be used once they have been programmed in the infotainment touchscreen.

To manage this feature, press the following icons the Infotainment touchscreen.



**Programming instructions**

**NOTICE**

Your vehicle must be within the operating range of the gate or garage door opener and the ignition should be switched on. Make sure you comply with the safety instructions even when synchronising the rolling

code.

1. To programme the button for the first time:
2. Switch on the ignition. **Do not start the engine.**
3. Press the button on the rear view mirror button you want to programme and follow the instructions displayed on the infotainment touchscreen.
4. If required, the remaining two buttons can be programmed.

*If you have a rolling code continue with the instructions in the next section.*

Follow the instructions below for rolling code synchronisation (the procedure will take less time with a second person to help).

1. Locate the training button (programming button) on the gate or garage door opener motor head unit. The exact location and colour of the button may vary by gate or garage door opener brand (refer to the operating instructions of your gate or garage door opener).
2. Switch on the ignition. **Do not start the engine.**
3. Press the button on the rear view mirror you want to synchronise.
4. Press the programming button on the gate or garage door opener motor head unit (which will usually activate a "programming status" light).
5. Proceed again with the instructions on the infotainment touchscreen.

*The gate or garage door opener should now recognise the programmed devices signal and activate when the appropriate button is pressed.*