

Field Campaign

Modification Bulletin

20-0033 - MB - EUR - YT - CAM0187 air intake damper and aftertreatment cover (DOT only)

Created Date : 9 September, 2025

Version	Changed Date	Group	Number
A	16 Sep 2025	20_Engine	0033

Air intake damper and aftertreatment cover YT193 DOT

i Introduction :

During the initial phase of series production of the YT193 DOT vehicle, Terberg implemented several product improvements aimed at enhancing reliability and uptime:

- **Aftertreatment System Cover:** The shape of the cover has been redesigned to prevent contact with the air inlet.
- **Air Intake Noise Damper:** The damper on the compressor air intake has been reinforced to better withstand vibrations and improve durability.

To ensure these improvements are applied to vehicles already in the field, we are launching a campaign to retrofit the updated components.

Important Note:

Some vehicles were already equipped with the improved noise damper during production. Therefore, the attached VIN list includes a column indicating whether the noise damper requires replacement for each specific vehicle.

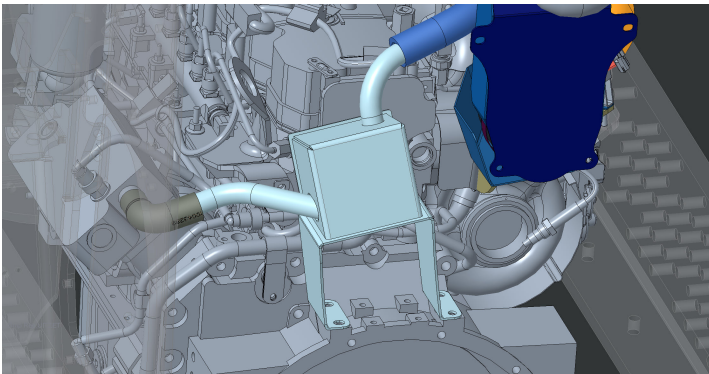

figure 1, noise damper on engine (old design)

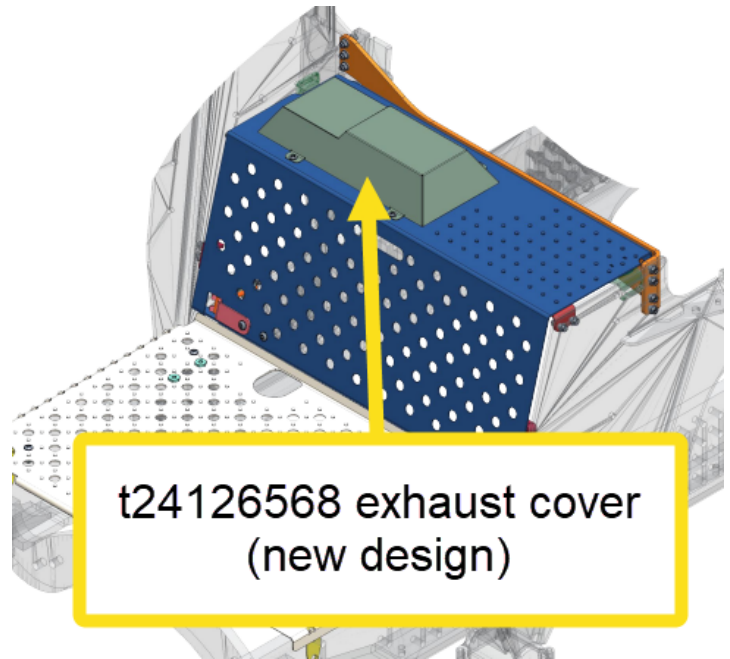

figure 2, exhaust cover

Parts and tools :

List of required parts :

Part	Qty	Description	Mandatory/Optional
t10043429	1	noise damper	Mandatory if required on VIN list
t24126568	1	exhaust cover	Mandatory
t10112217	1	air intake	Optional

List of required tools :

The modification can be performed with standard tools.

Recommended Action :

WARNING



Before starting any work make sure you read, understand and follow all safety measures and warnings in the driver and maintenance manual that are applicable to this vehicle.

Note: step 2 to 7 only apply if the noise damper needs replacment.

1. Park the vehicle in a safe place, apply park brake and switch engine off.
2. Tilt the cabin fully.
3. Remove the hoses that connect tot the air intake damper.
4. Reomove the bolts that connect the damper to engine housing.
5. Install new damper, re-use flange bolts M8x20, t29064192. Torque these bolts to 25Nm.

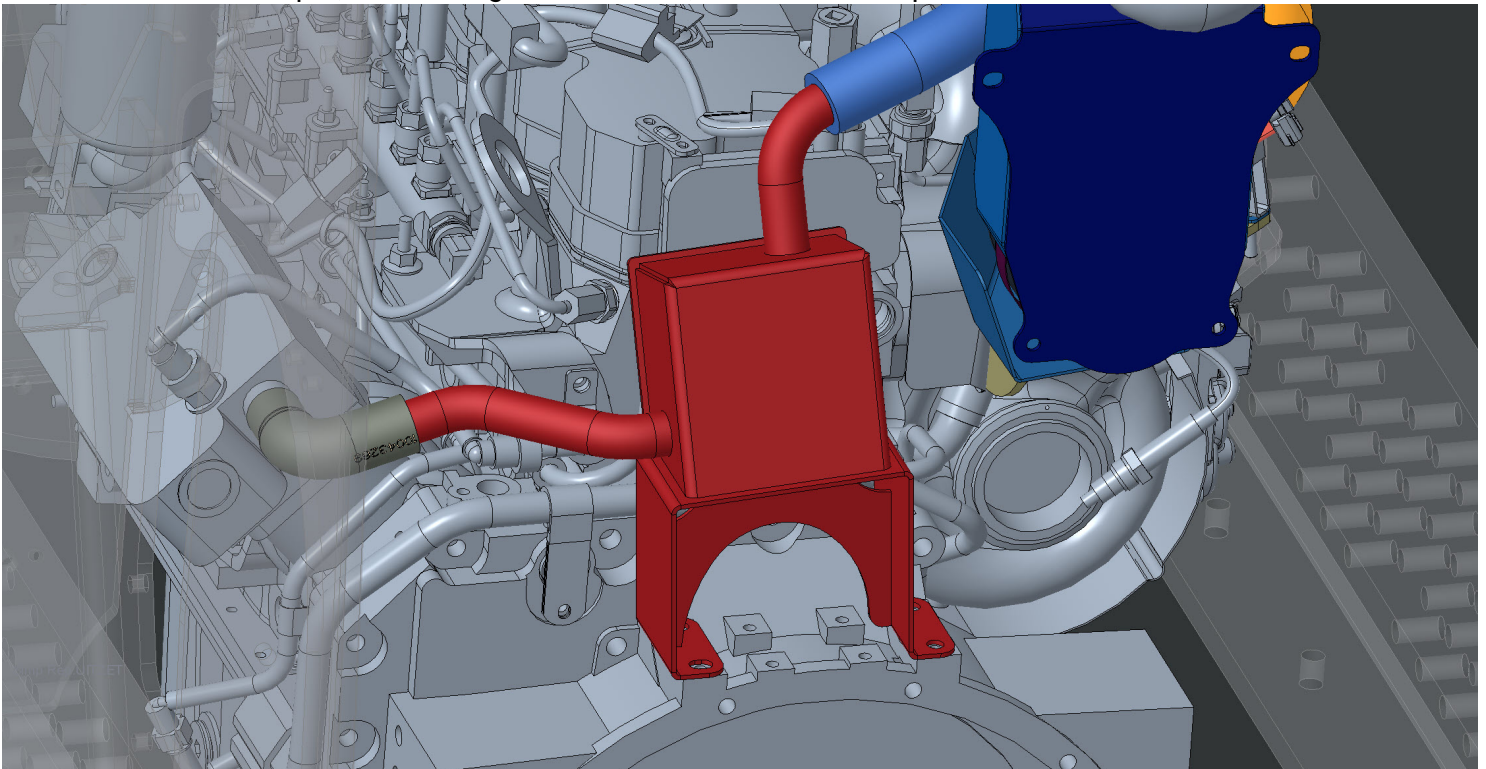

figure 3, damper t10043429 new design.

6. Re-install the hoses tot he air intake damper.
7. Finish work under the cab and lower cabin.

8. Remove the cover t24126568 from the exhaust/aftertreatment cover.
9. Check if the cover has been wearing on the air intake hose t10112217. Replace this intake hose when visibly worn due to contact with the cover. See figure 4.

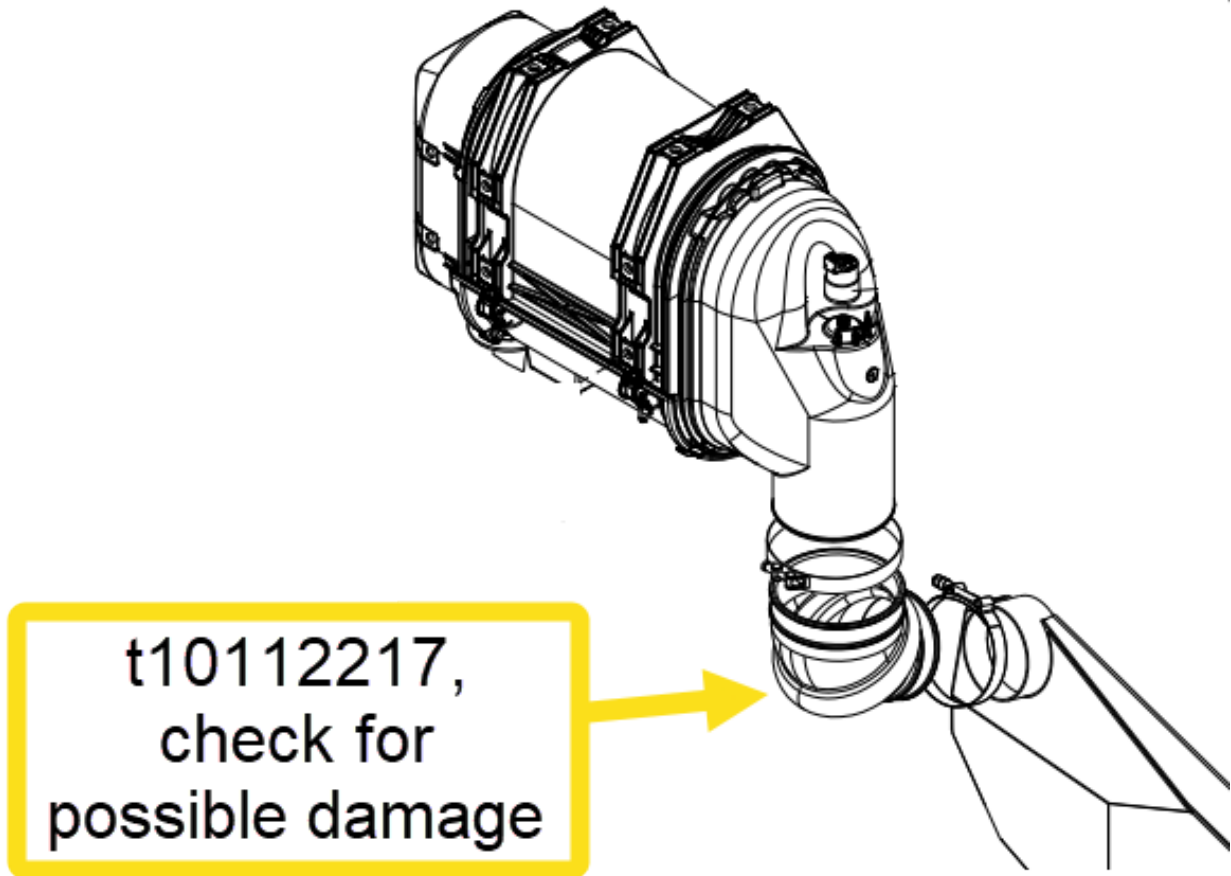

figure 4, intake hose t10112217

10. Install the new cover t24126568 with the stepped design, as in figure 2.
11. Re-use the 4 bolts t29010326 M8x20 and tighten to 25 Nm.
12. Modification done.

1 Warranty Instructions for this Campaign :

1.1 General :

Campaign Name :	Air intake damper and aftertreatment cover (DOT only)
Campaign Number :	CAM0187

1.2 Priority :

End Date :	July first, 2026 When this end date cannot be met please contact our warranty department before the end date.
Campaign Type :	Field Campaign
Priority level :	Medium
Explanation :	Components can fail when campaign is not performed, but this will not immediately harm the vehicle

1.3 Labour :

Max. amount of labour to be claimed :	0,75 hour when exhaust cover and air intake damper need replacement 0,25 hour when only exhaust cover needs replacement
Administration fee : (this includes ordering parts, software etc)	0,5 hour

1.4 Software Required :

- YES** → Use of product support portal mandatory
 NO

1.5 Travel costs :

Travel costs for visiting the vehicle can't be claimed as the campaign must be combined with a planned service visit. When no service visit will be planned before the end date of the campaign a warranty pre authorization ticket must be made, in which authorization for travel costs is requested.

1.6 Parts costs :

All parts that are marked with 'mandatory' in the parts overview paragraph can be claimed. Part marked with Optional can be claimed when a good picture is added in the warranty claim that explains why this part was replaced.

1.7 Involved vehicles :

A list with affected VIN numbers is supplied per e-mail to a distributor. Vehicles that are not on the list are not part of the campaign. In the warranty portal the campaign is made available for these VIN's as well.

Note: the VIN list does contain a list that states if the noise damper requires replacement or not.

1.8 Reporting and Claiming :

1. Create a warranty request to claim the required costs for this modification.
2. Use warranty type campaign
3. Choose campaign number (PIP number): CAM0187
4. Warranty department will process your request.
5. You will receive a credit note.