

TECHNICAL INSTRUCTIONS

FOR

25LD01

REAR TRACTION MOTOR CABLE CORROSION

**CERTAIN 2022-2024 NX350h/ NX450h+, CERTAIN 2023-2024 RX350h,
CERTAIN 2024 RX450h+ VEHICLES**

The repair quality of covered vehicles is extremely important to Lexus. All dealership technicians performing this LSC are required to successfully complete the most current version of the E-Learning course "Safety Recall and Service Campaign Essentials". To ensure that all vehicles have the repair performed correctly, technicians performing this LSC repair are required to currently hold at least one of the following certification levels:

- LIC209A - Electrified Powertrain Vehicle Repair
or
- MCR225A - (Electrified Powertrain Safety and Power Down)

It is the dealership's responsibility to select technicians with the above certification level or greater to perform this LSC repair. Carefully review your resources, the technician skill level, and ability before assigning technicians to this repair. It is important to consider technician days off and vacation schedules to ensure there are properly trained technicians available to always perform this repair.

I. OPERATION FLOW CHART

The flow chart is for reference only. **DO NOT** use it in place of the full technical instructions. Follow **ALL** steps outlined in the full technical instructions to confirm that the campaign is completed correctly.

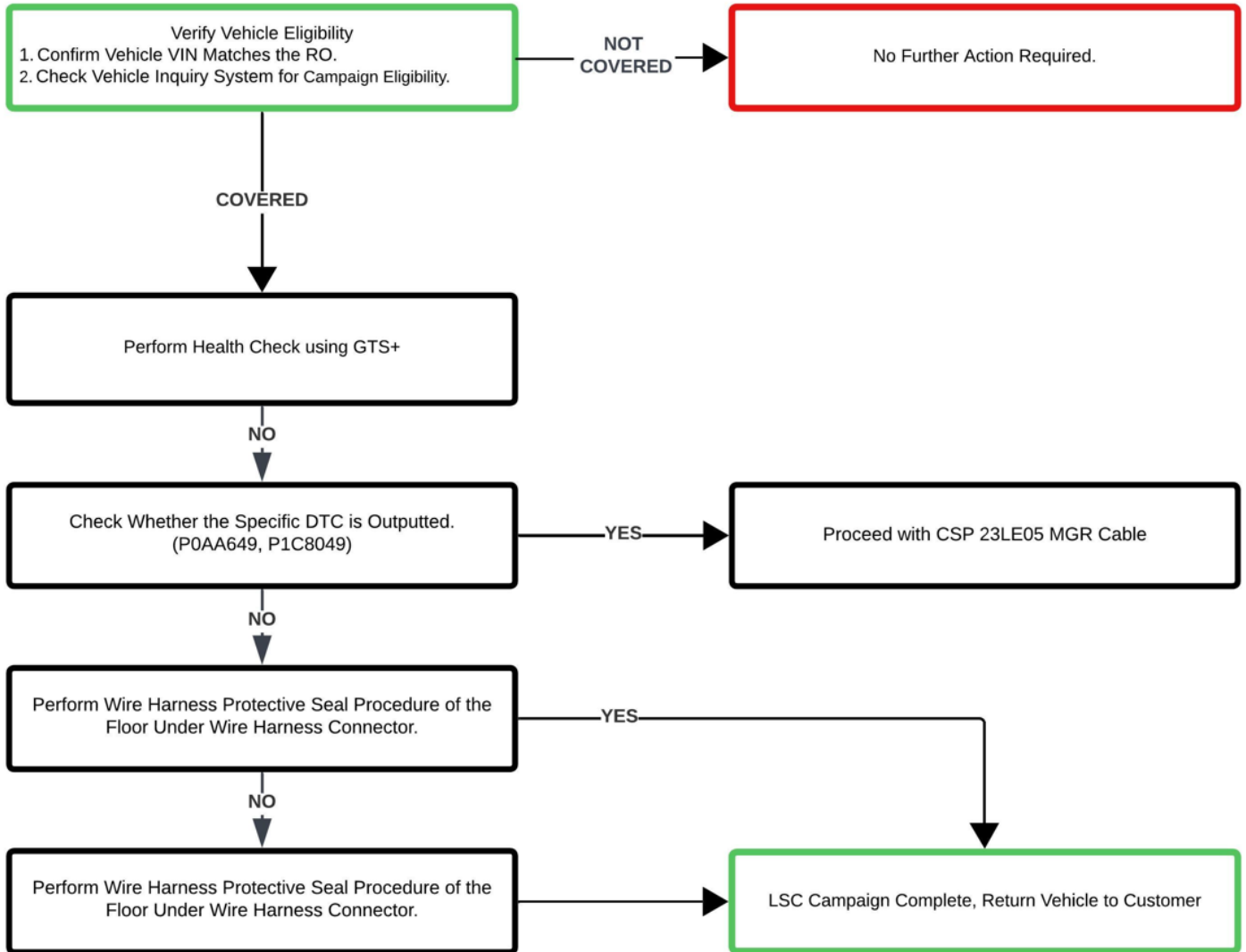

Note: If the relevant DTCs are detected after performing the health check, and for any reason, the CSP repair cannot be performed on that service visit, the codes should **NOT** be cleared and the customer.

III. WORK PROCEDURE TABLE OF CONTENTS

BACKGROUND	SECTION IV.
SAFETY PRECAUTIONS	SECTION V.
CHECK FOR DTCs	SECTION VI.
INSPECT FLOOR UNDER WIRE CONNECTOR	SECTION VII.
HYBRID VEHICLE POWER DOWN PROCEDURE	SECTION VIII.
A. DISCONNECT AUXILIARY BATTERY	
• NX350h	
• RX350h	
B. PERFORM VEHICLE POWER DOWN PROCEDURE	
WATERPROOF FLOOR UNDERWIRE CONNECTOR	SECTION IX.
RETURN VEHICLE TO ITS ORIGINAL CONDITION	SECTION X.
APPENDIX	SECTION XI.

IV. BACKGROUND

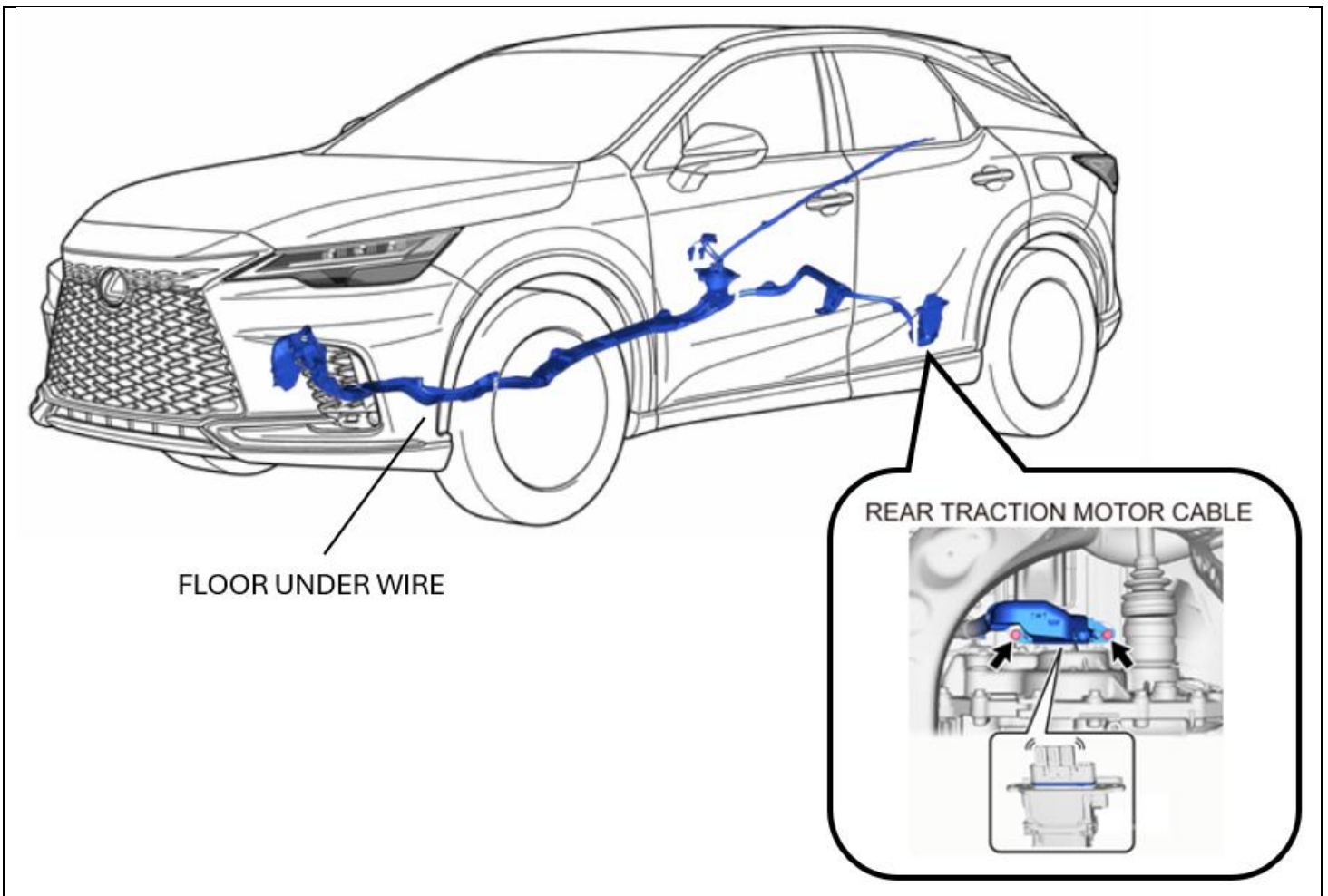

V. SAFETY PRECAUTIONS

A. PRECAUTIONS WHEN WORKING ON THE HIGH VOLTAGE SYSTEM



- Always remember “SAFETY FIRST”.
- Be extremely careful when handling high voltage components.
- TIC209A or Completion of MCR225C is Required!

1. CAUTION WITH "WORKING AT HIGH VOLTAGE" SIGN

- a. Put a "WORKING AT HIGH VOLTAGE" sign on the roof to caution other technicians.

NOTE: The next page illustrates a caution sign sheet. Print out a copy and use it.

2. BEWARE OF PERSONAL EFFECTS FOR SHORT-CIRCUIT PREVENTION

NOTE: To prevent short circuits, DO NOT wear metal goods, such as wristwatches or jewelry.

3. TOOL INSULATION

- a. Use insulated tools to prevent a short circuit.

4. WEAR INSULATING GLOVES

- a. Wear insulating gloves to prevent electric shock when working with or around the high-voltage circuit (orange wires and connectors).
- b. **DO NOT** use wet or damaged insulating gloves.
- c. When the insulating gloves are dirty, clean them before using them and follow the instructions in the glove manual.
- d. Use both sets of insulated gloves if possible.

5. HANDLE PROPERLY THE SERVICE PLUG GRIP

- a. Before working with a high-voltage system, disconnect the negative terminal of the auxiliary battery and then the service plug grip. Wait at least 10 minutes to discharge the high-voltage capacitor inside the inverter with converter assembly.
- b. Keep the removed service plug grip in your pocket to prevent other technicians from accidentally installing it while servicing the vehicle.

6. INSULATE AFTER DISCONNECTION OF HIGH VOLTAGE CIRCUIT

7. Soon after removing the connectors and terminals in a high-voltage system, insulate them with insulation tape.

8. CONNECT HIGH VOLTAGE TERMINAL

- a. To prevent defects such as burnout due to poor connection, check the following:
 - Do not allow any foreign matter or water to enter the inverter with converter assembly.
 - Use a torque wrench to check the tightening torques of the terminals.

9. **DO NOT** USE AN AIR TOOL OR A POWER TOOL

- a. Once the cover is removed, **DO NOT** use an air or power tool to remove dust.



**CAUTION:
HIGH-VOLTAGE
DO NOT TOUCH.**

Person in charge: _____

**CAUTION:
HIGH-VOLTAGE
DO NOT TOUCH.**

Person in charge: _____



When performing work on the HV system, fold this sign and put it on the roof of the vehicle.

VI. CHECK FOR DTCs

1. CHECK FOR DTCs

- Perform Health Check using GTS+
- Confirm whether any of the following DTCs are present:

DTC:

- P0AA649 (Hybrid/EV Battery Voltage System Isolation Internal Electronic Failure)
- P1C8049 (Hybrid/EV Battery Voltage System Isolation (Rear Motor Area) Internal Electronic Failure)
- Check the HV System for any isolation fault codes.

Judgment	DTCs	Action
NO	Not present	Proceed to Section VII .
YES	Present	<ul style="list-style-type: none">If P0AA649 or P1C8049 or AM Static is present: CSP 23LE05 will need to be performed.Proceed to Section X.If any other HV System isolation fault codes are present: Codes must be diagnosed and repaired prior to performing this LSC.

VII. INSPECT FLOOR UNDER WIRE CONNECTOR

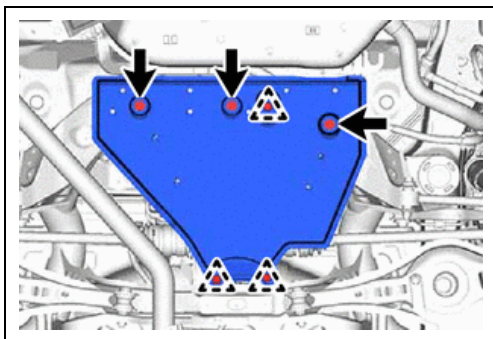

1. REMOVE THE NO. 1 FLOOR UNDER COVER (IF APPLICABLE)

- Raise the vehicle on a lift.
- Remove the (3) bolts, (3) clips, and No. 1 floor under cover from the rear suspension member sub-assembly.



DO NOT touch the floor under wire harness or the connector.

2. VISUALLY INSPECT THE FLOOR UNDER WIRE CONNECTOR

- Confirm if the vehicle has the updated floor under wire harness connector currently installed.



DO NOT touch the floor under wire harness or the connector. Only a visual inspection of the connector housing will be performed.

Does the vehicle currently have the updated connector installed?

- UPDATED:** LSC not applicable. Return the vehicle to its original condition, then return the vehicle to the customer.
- NON-UPDATED:** Proceed to [Section VIII](#): Hybrid Vehicle Power Down Procedure.

Updated connector has a protruding orange seal present.

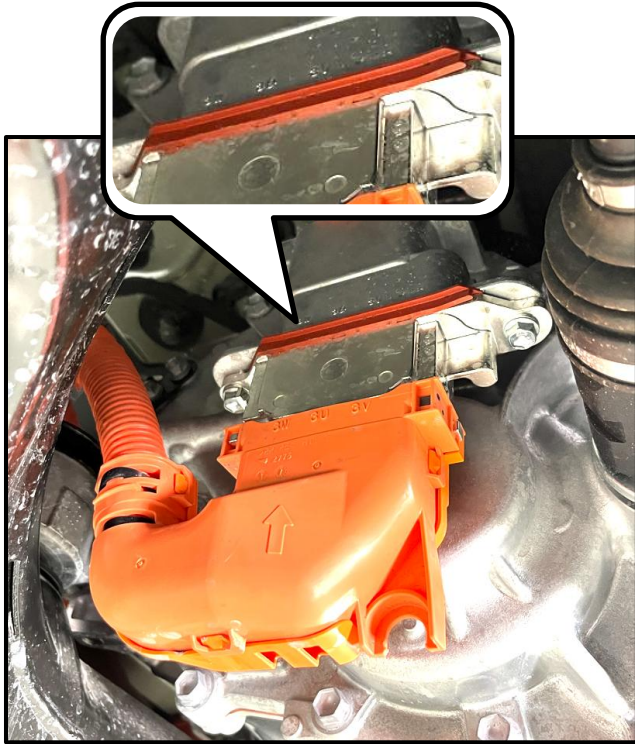

Non-updated connector has a flush black seal present.

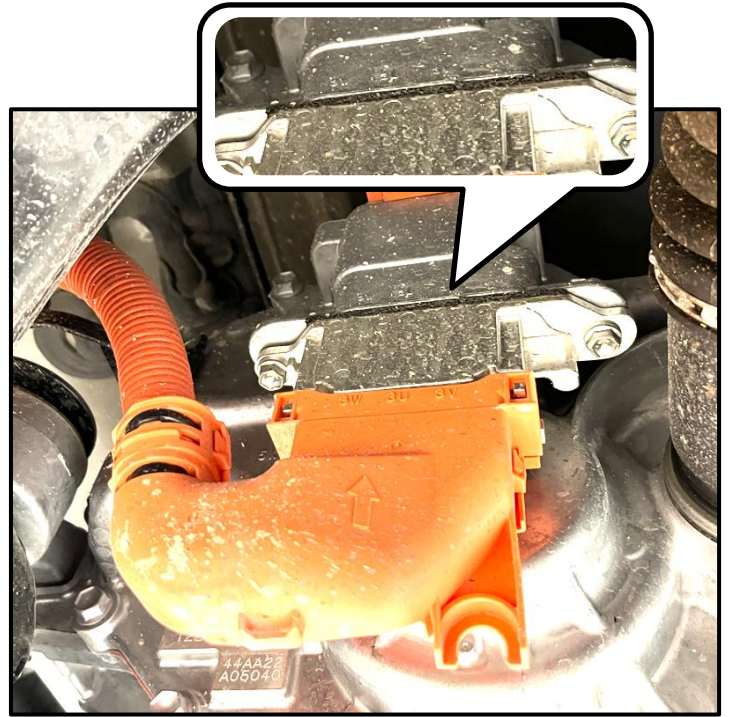

VIII. HYBRID VEHICLE POWER DOWN PROCEDURE

A. DISCONNECT AUXILIARY BATTERY

NX350h & NX450h+

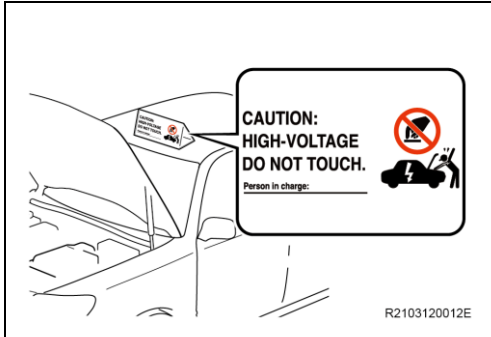

1. **PLACE THE PROVIDED CAUTION SIGN ON THE ROOF OF THE VEHICLE**
 - a. Put a "CAUTION HIGH-VOLTAGE DO NOT TOUCH" sign on the roof to caution other technicians.

NOTE: A safety precautions sheet is available in [Section VI](#), **SAFETY PRECAUTIONS**. Make a copy and use it when you work.

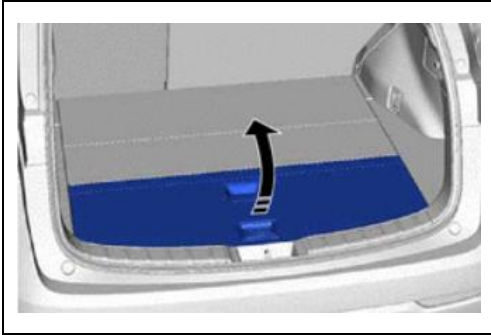

2. **REMOVE DECK BOARD ASSEMBLY**
 - a. Remove the deck board assembly.

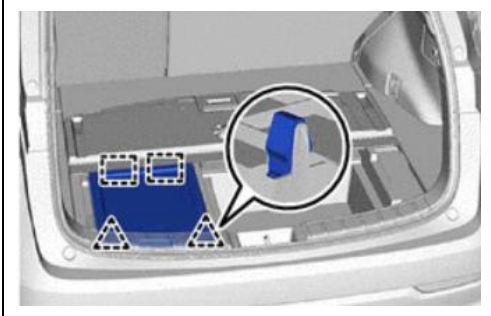

3. **REMOVE REAR NO. 2 FLOORBOARD**
 - a. Detach the (2) clips and (2) guides and remove the luggage trim service hole cover.



4. **DISCONNECT CABLE FROM NEGATIVE AUXILIARY BATTERY TERMINAL**
 - a. Loosen the nut and disconnect the cable from the negative (-) auxiliary battery terminal.

RX350h & RX450h+

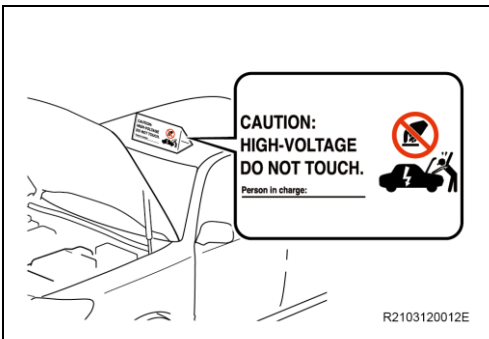

1. **PLACE THE PROVIDED CAUTION SIGN ON THE ROOF OF THE VEHICLE**
 - a. Put a "CAUTION HIGH-VOLTAGE DO NOT TOUCH" sign on the roof to caution other technicians.

NOTE: A safety precautions sheet is available in [Section VI](#), **SAFETY PRECAUTIONS**. Make a copy and use it when you work.

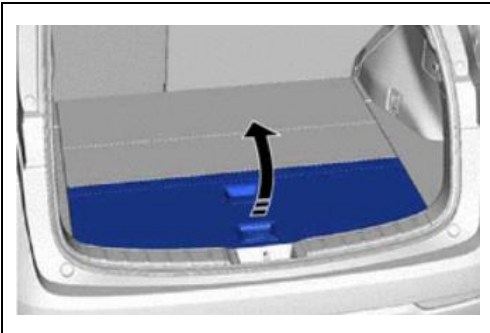

2. **REMOVE DECK BOARD ASSEMBLY**
 - a. Remove the deck board assembly.

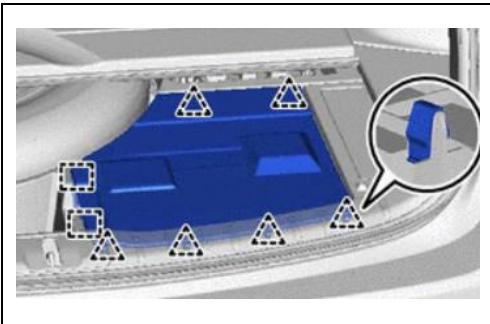

3. **REMOVE REAR NO. 2 FLOORBOARD**
 - a. Detach the (4) clips and (2) guides and remove the luggage trim service hole cover.

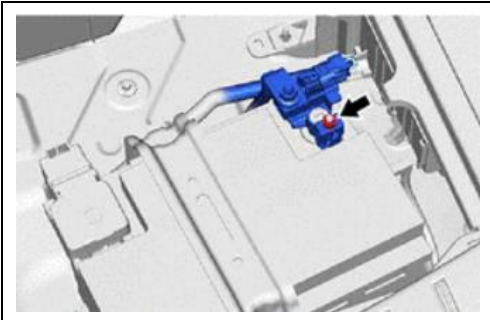

4. **DISCONNECT CABLE FROM NEGATIVE AUXILIARY BATTERY TERMINAL**
 - a. Loosen the nut and disconnect the cable from the negative (-) auxiliary battery terminal.

B. PERFORM POWER DOWN PROCEDURE

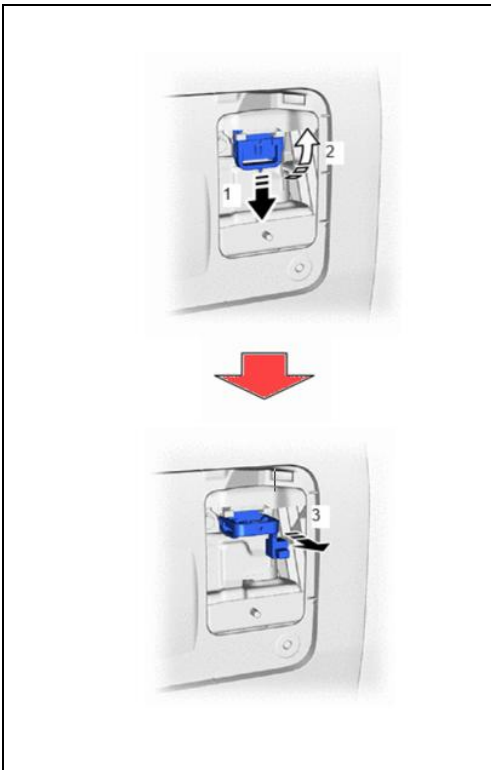

Service_Plug_Grip.MOV



1. REMOVE SERVICE PLUG GRIP

CAUTION: Be sure to wear insulated gloves.

- a. Refer to the following Repair Manual link for the proper procedure:
HYBRID / BATTERY CONTROL: SERVICE PLUG GRIP: REMOVAL:

- NX350h: [2022-2025](#)
- RX350h: [2023-2024](#)

HINT: Waiting at least 10 minutes is required to discharge the high-voltage capacitor inside the inverter with converter assembly.

NOTE:

- Keep the removed service plug grip in your pocket to prevent other technicians from accidentally installing it while servicing the vehicle.
- After removing the service plug grip, turning the ignition switch on (READY) may cause a malfunction. Do not turn the ignition switch on (READY) unless instructed by the repair manual.
- Do not touch the terminals of the service plug grip.

HINT: Review the video for the service plug grip removal process.

2. REMOVE CONNECTOR COVER ASSEMBLY

CAUTION: Be sure to wear insulated gloves.

- a. Remove the bolt (B).
- b. Using a T25 "TORX" socket wrench, remove the bolt (A) and connector cover assembly from the inverter with converter assembly.

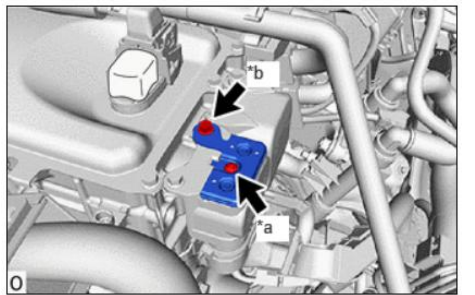

*a	Bolt (A)
*b	Bolt (B)

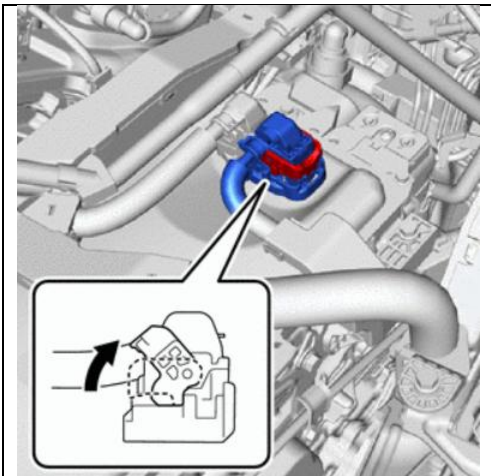

3. DISCONNECT ENGINE ROOM MAIN WIRE

2. Move the lock lever while pushing the lock on the connector and disconnect the inverter with the converter assembly connector.

NOTE: Do not allow any foreign matter or water to enter the inverter with converter assembly.

HINT: Review the video for engine room harness connector removal.

Disconnect_EngineRoom_Main Wire.MP4



4. CHECK TERMINAL VOLTAGE

CAUTION: Be sure to wear insulated gloves.

- a. Using a voltmeter, measure the voltage between the terminals of the 2-phase connectors.

Standard Voltage: 0 V DC

NOTE: DO NOT allow any foreign matter or water to enter the inverter with converter assembly.

HINT: Use a Class III (600V) rated voltmeter.

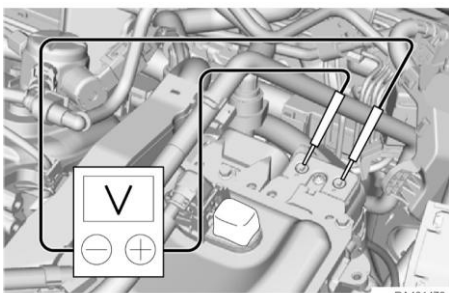

RA431470



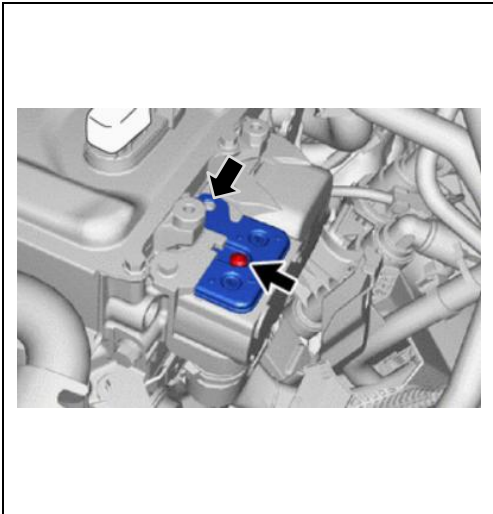

5. INSTALL CONNECTOR COVER ASSEMBLY

CAUTION: Be sure to wear insulated gloves.

3. Temporarily install the connector cover assembly to the inverter with the converter assembly.
 - a. Using a T25 "TORX" socket wrench, install the bolt.

Torque:

4.5 N·m {40 in·lbf}

- b. Install the 10mm bolt. (bolt B).

Torque:

8.0 N·m {71 in·lbf}

IX. WATERPROOF THE FLOOR UNDERWIRE CONNECTOR

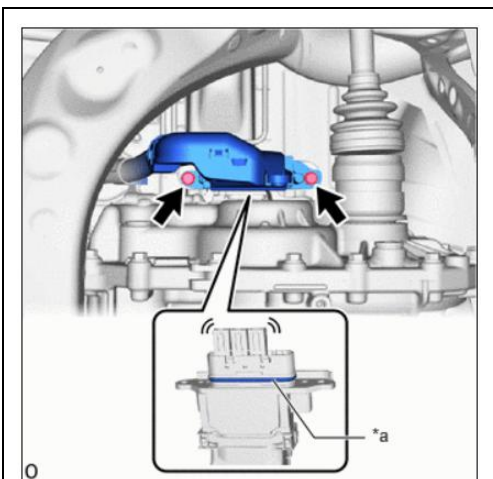

0

*a Waterproof Seal

1. DISCONNECT FLOOR UNDER WIRE

- a. Remove the (2) bolts and HV floor under wire from the rear traction motor with transaxle assembly.

NOTE:

- *Do not damage the terminals, interlock connector or rear traction motor with transaxle assembly during disconnection.*
- *Do not touch the waterproof seal or terminals of the connector.*
- *Do not allow any foreign matter or water to enter the rear traction motor with transaxle assembly.*
- *Although the connector may feel loose, this is not due to a malfunction.*

MGR_Cable_Unplug.MOV

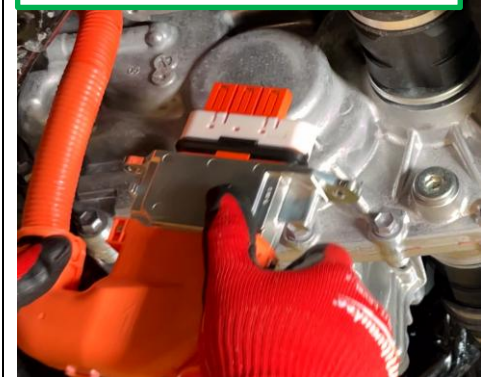

HINT: Review the video of the MGR cable removal process.



b. Disconnect the harness clamp.

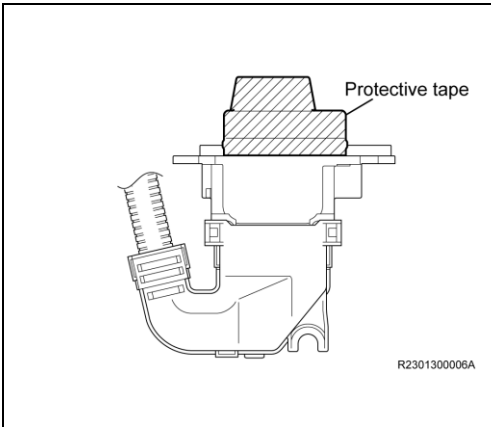

2. APPLY PROTECTIVE TAPE

a. Apply protective tape to the harness connector.

HINT: Review the video for applying tape to the MGR connector.

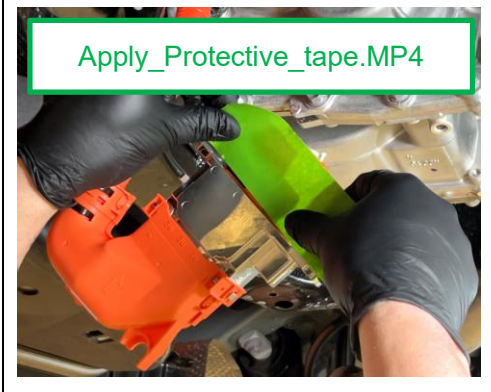

3. REMOVE WIRING HARNESS PROTECTOR

- a. Disengage the (5) claws to separate the wiring harness protector cover (for type A and type B).
- b. Disengage the (4) claws to separate the wiring harness protector cover (for type C).

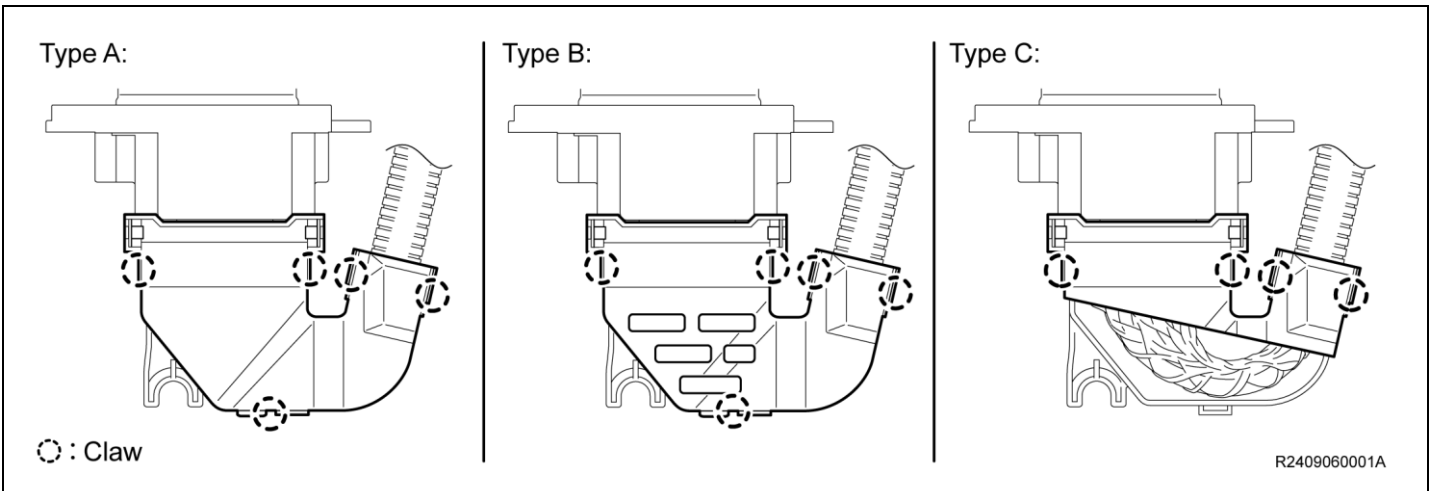

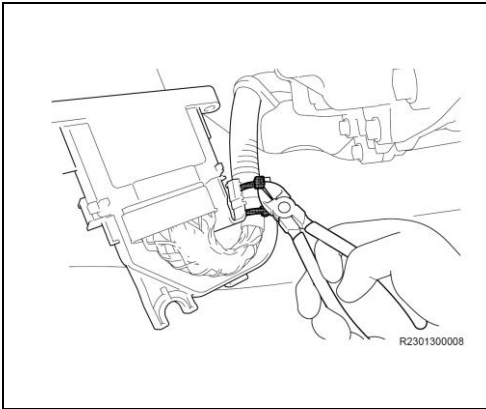

- c. Cut the (2) zip ties to remove the wiring harness protector from the floor under wire.

Front_MGR_Cover_Removal.MOV



Remove_Zipties.MOV



HINT: Review the videos for removing the MGR cable cover.



DO NOT use brake cleaner or any other solvent to clean the connector housing.

4. CLEAN THE CONNECTOR

- a. Confirm the cleaning area.
 - Clean all around the connector and the base of the wire harness as indicated in the video below.



- b. Use 200-400 grit sandpaper and brass wire brush to clean.

HINT: Brass brush may wear quickly, be sure to replace the brass brush when brass bristles are worn or ineffective.

NOTICE: DO NOT USE STEEL WIRE BRUSH to clean the connector base. Damage to the wire harness shielding will occur!

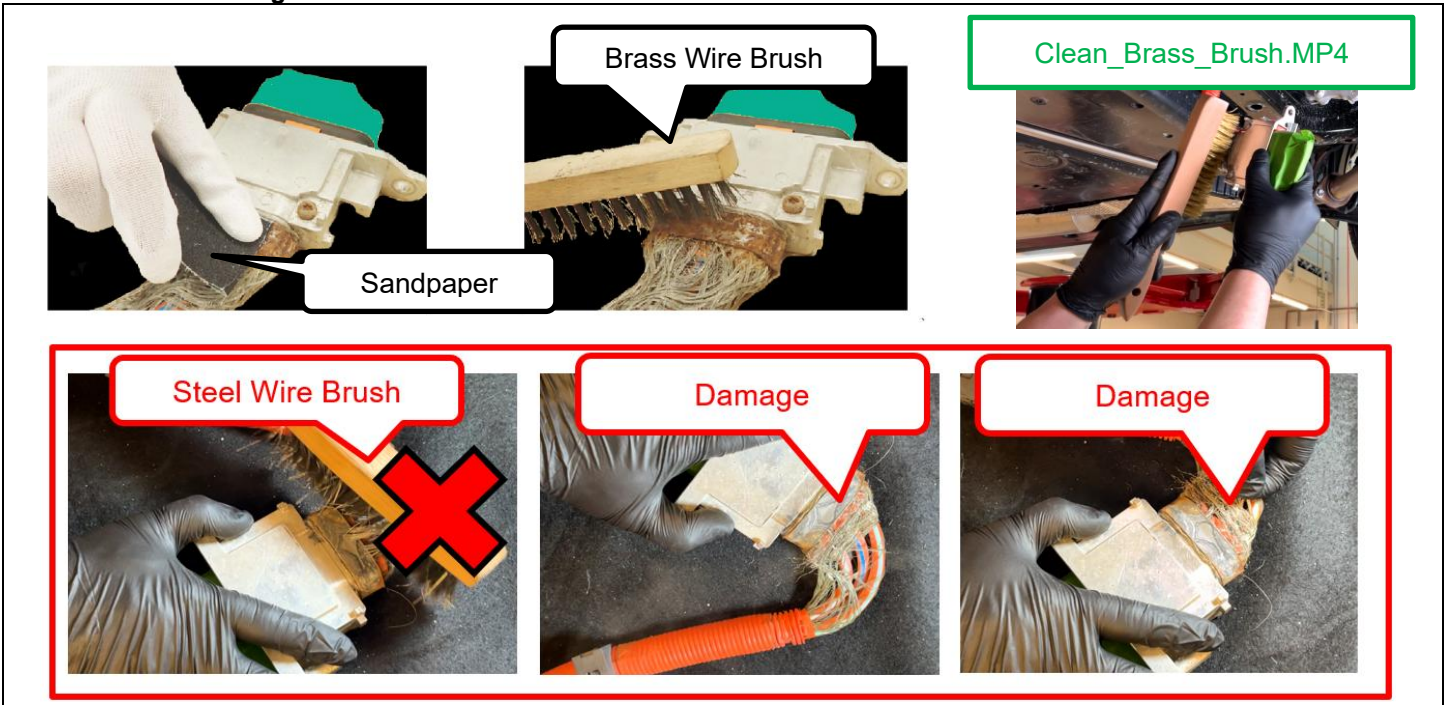

c. Confirm that the corrosion is properly removed.

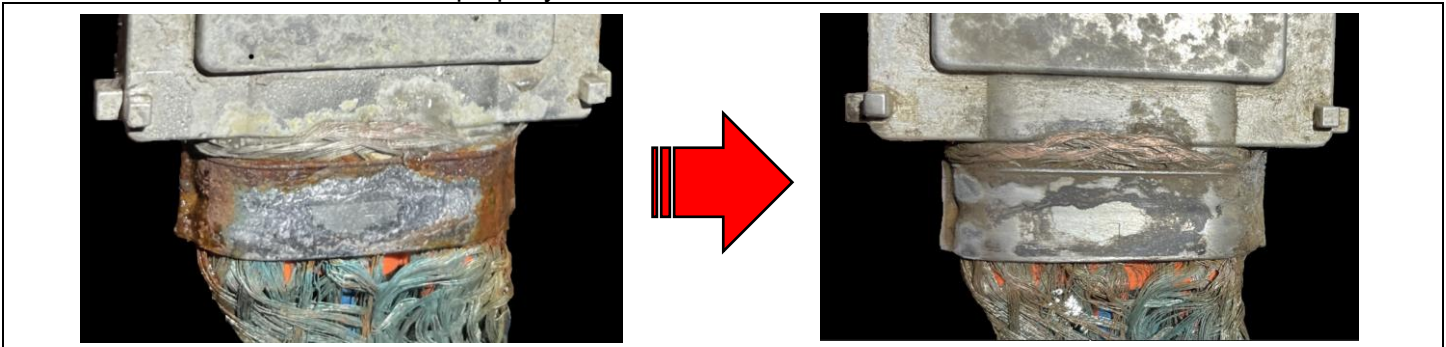

d. Add tape to the connector housing opening to prevent debris from entering. Then, using a wire brush and sandpaper, remove any corrosion from the inverter with converter assembly mating surface area.

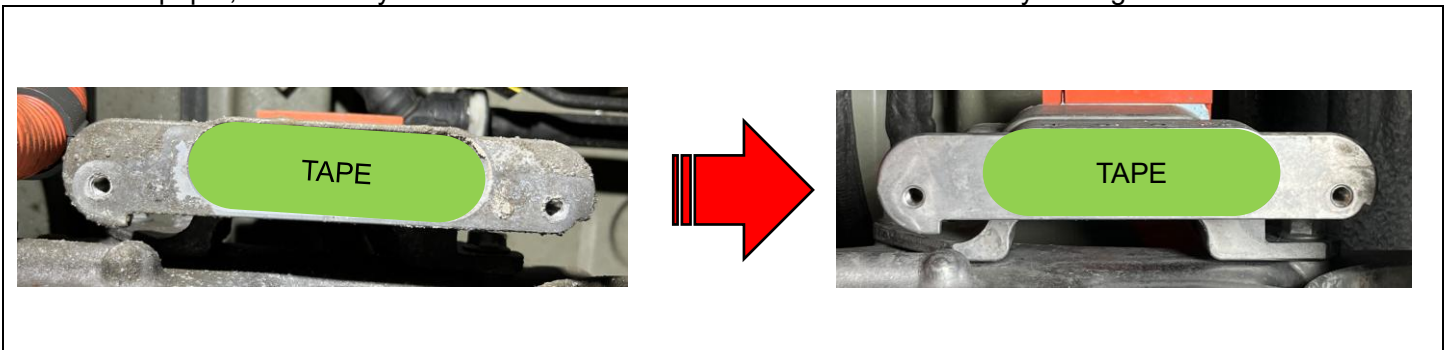

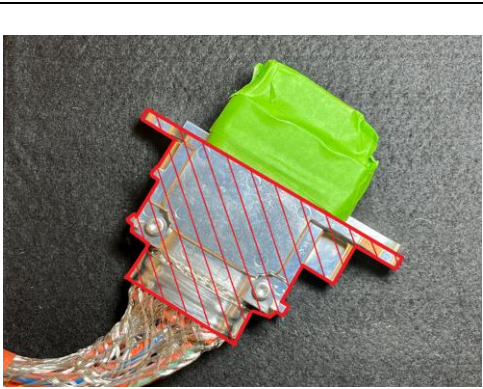

DO NOT use brake cleaner or any other solvent to clean the connector housing.

- e. Using an **isopropyl alcohol wipe**, gently clean the connector housing in the red shaded area as seen in the illustration.

NOTE: **ONLY** apply the **isopropyl alcohol wipe** in the areas indicated in red, as shown in the corresponding illustrations.



- f. Use a heat gun to dry the connector surface.

HINT: Review the video for the drying process.

NOTICE: (When using a heat gun)

- **Damage can occur to the connector if the harness is overheated.**
- **DO NOT** apply heat from a heat gun to the same area for an extended period.
- **Focus heat on the mesh shielding portion of the connector.**
- **Use shop air to blow out any residual moisture and/or debris from connector clamp and mesh shielding.**
- **Check to ensure the cleaned area is completely dry before proceeding with the repair. Use shop air to blow out any remaining moisture and debris from the connector mesh shielding and clamp.**

5. APPLY WIRE HARNESS REPAIR TAPE

- a. Review the numbered sections of wire harness repair tape.

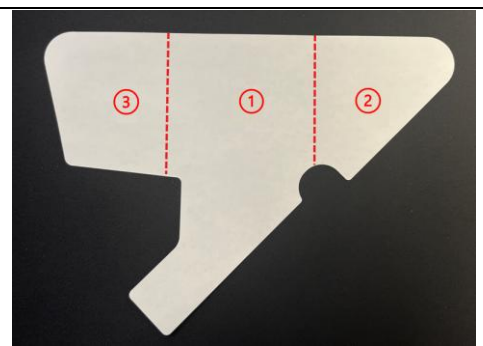

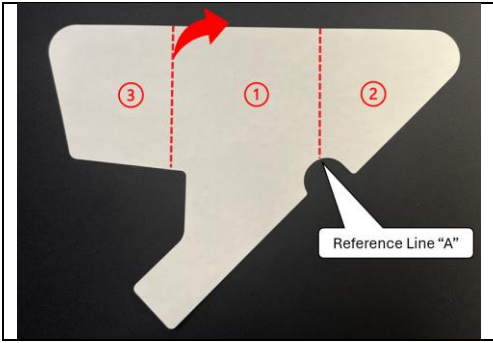

b. Remove the backing paper ① and confirm the position of reference line "A".

c. Align the reference line "A" and align the tape top edge with the reference line "B" then apply the repair tape.

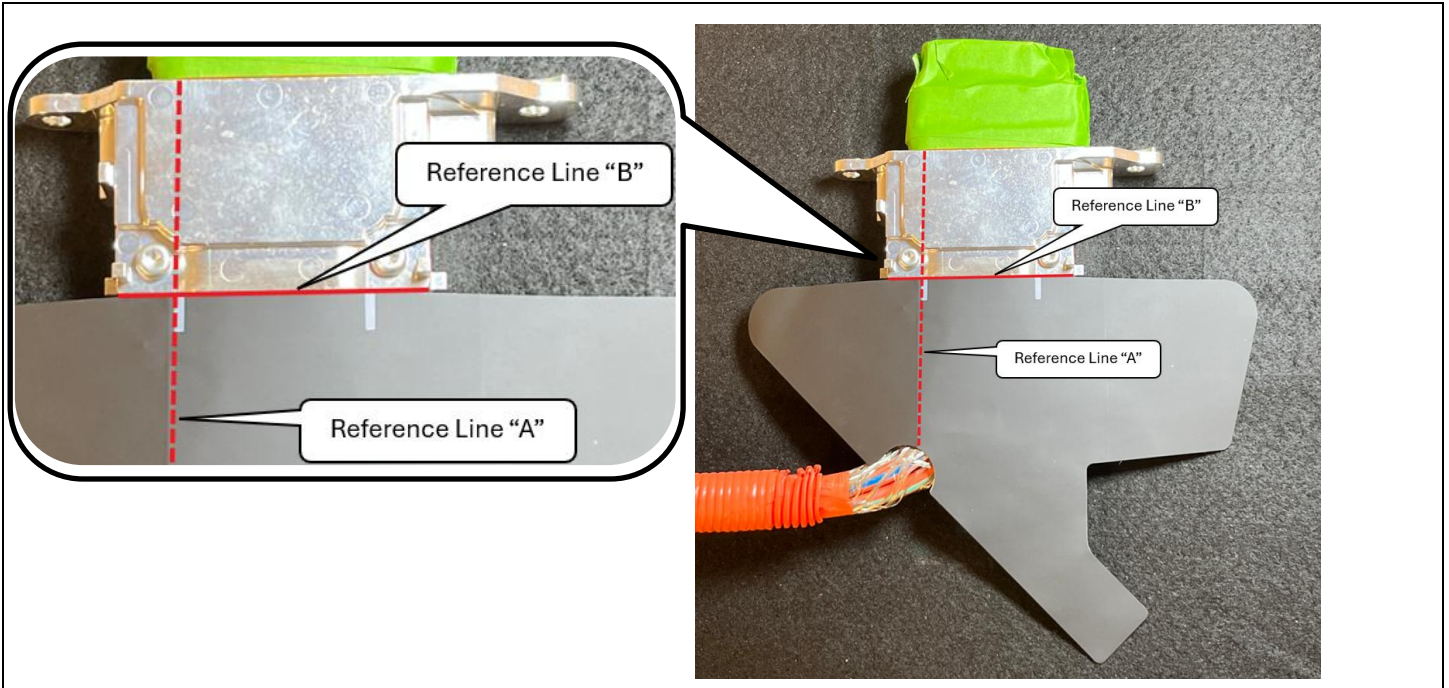

d. Remove the backing paper ② and apply repair tape, pulling it to align the top edge and reference line "C".

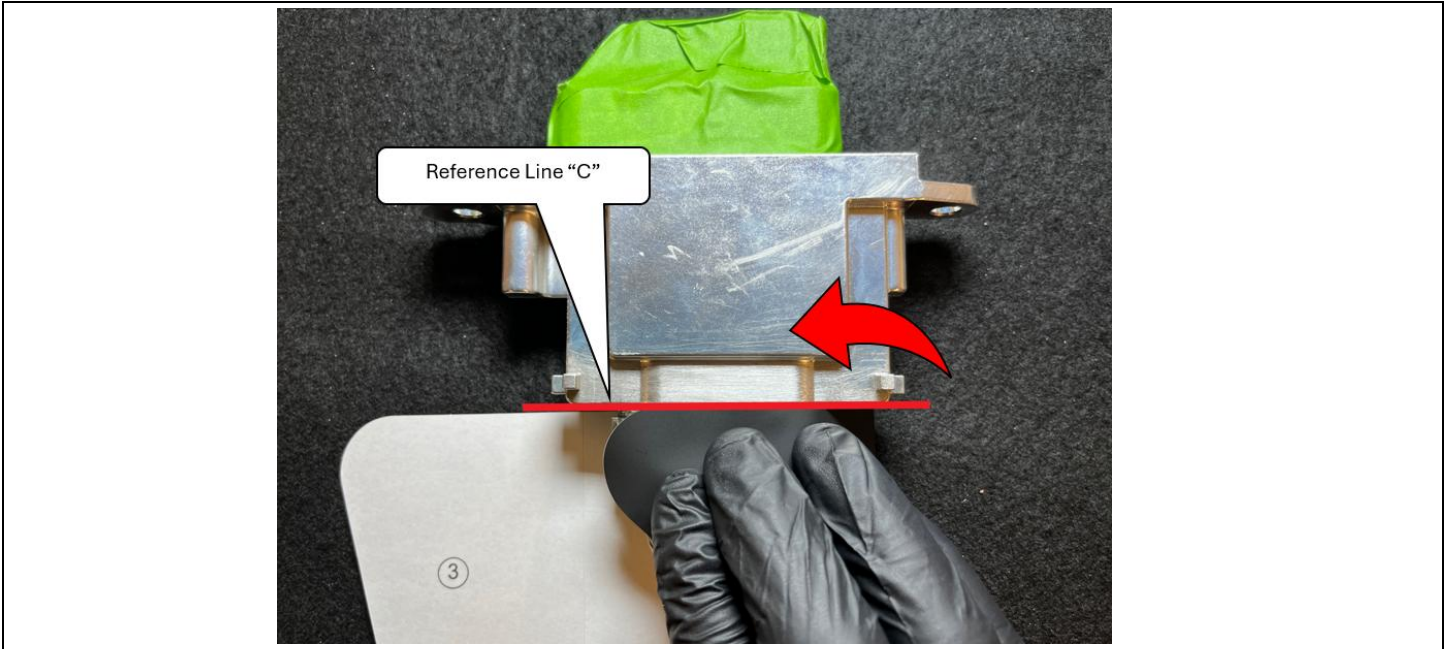

e. Remove the backing paper ③ and apply tape, pulling it so that the tape's top edge and reference line "C" are aligned.

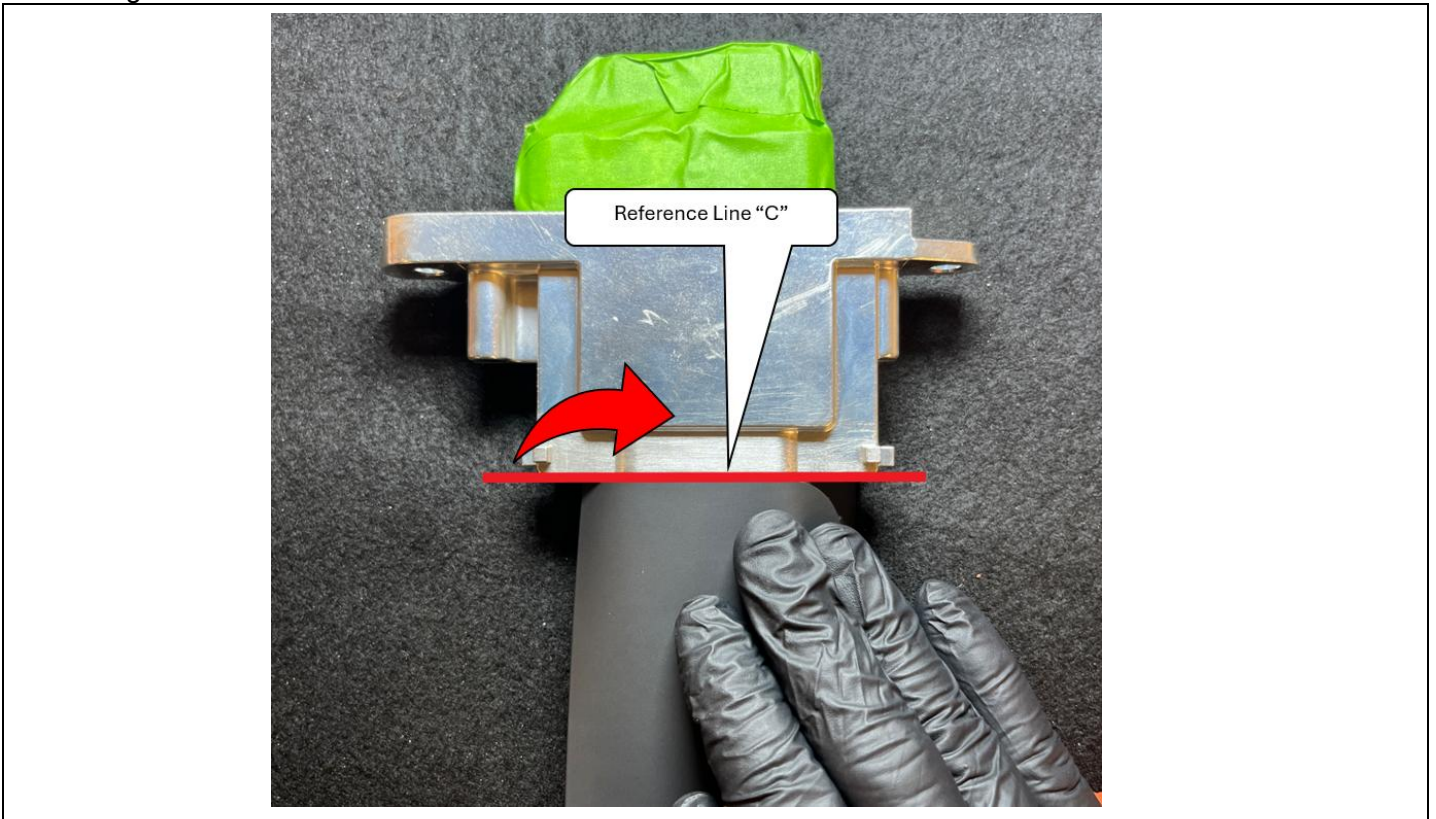

f. Apply the rest of the tape by pulling then wrapping it snug to the harness connector.



Zipper_Tubing_Application.MP4



HINT: Review the video to perform the vehicle's MGR repair tape installation procedure on the vehicle.

g. Confirm that the tape is applied correctly.

NOTE: Tail end of tape may leave small gap before orange tubing begins. Do Not attempt to add extra tape or FIPG to this section.

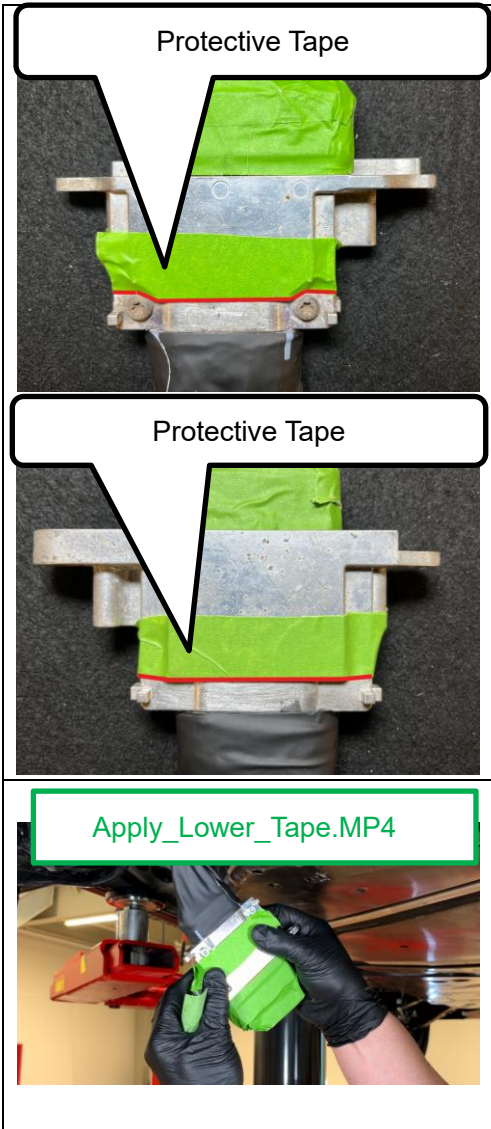

6. APPLY FIPG TO THE FLOOR UNDER WIRE CONNECTOR

- a. Apply protective tape to avoid adhesion of FIPG to the upper portion of the MGR connector.

NOTE: Be sure to match the bottom of the tape with the **red line** in the illustrations.

HINT: Review the video for tape installation.

- b. Review the area where FIPG will be applied to the connector in **red**.

HINT: Trim the FIPG nozzle to ensure the correct bead is applied to the connector.

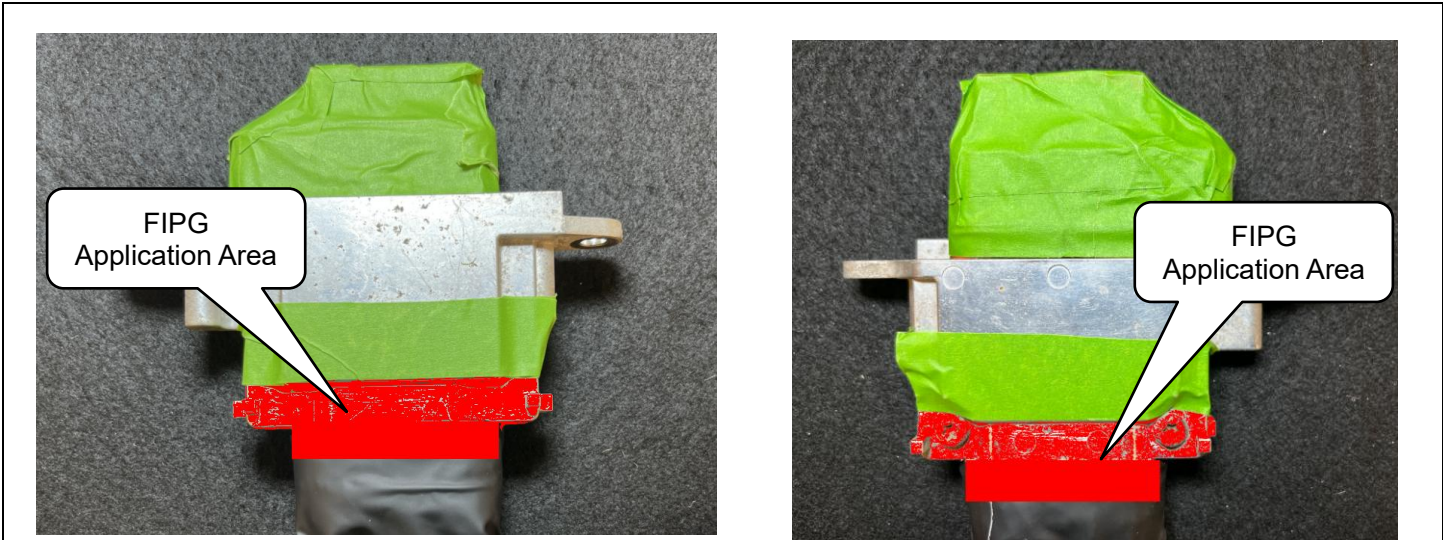



FIPG_Application_Lower_Connect or.MP4



c. Trim the FIPG nozzle to the 2nd notch to ensure the proper amount is applied to the connector surface.

- d. Apply FIPG all around the connector cover contacting area and the base of the wire harness.
- e. After applying FIPG, smooth the packing surface using a spatula to free the surface from gaps or air bubbles.

HINT: Review the video for the FIPG application on the vehicle.

- f. Check that the FIPG surface is free from gaps and air bubbles.
- g. Remove the masking tape.

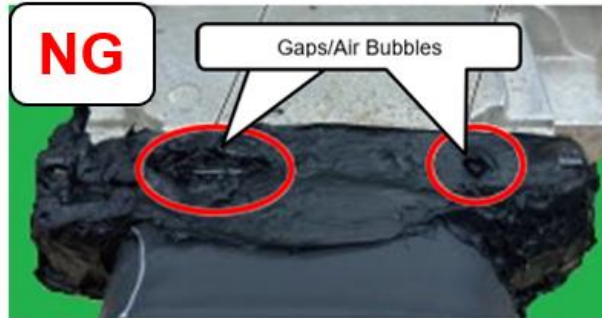

Judgment	Condition	Action
OK	FIPG is appropriately applied.	<ul style="list-style-type: none"> • Proceed to Step 7.
NG	Air pockets or gaps exist.	<ul style="list-style-type: none"> • Reapply FIPG to the connector, recheck for air pockets and gaps, and repeat Step 6e.

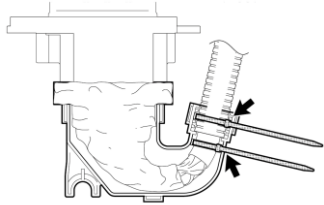

R2301300012

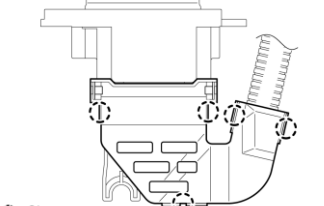

○ : Claw

R240900002A

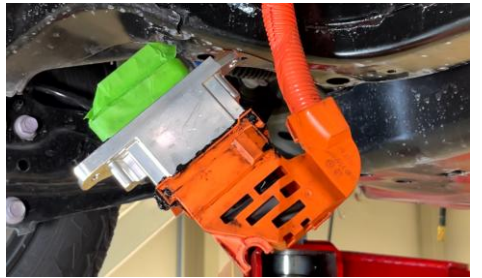

Cover_Installation.MP4



7. INSTALL NEW MGR CONNECTOR COVER

- Remove the protective tape installed in step 3(a).
- Set the **NEW** MGR connector cover on the floor under the wire.
- Secure the MGR connector cover with (2) **NEW** zip ties.
- Cut off the excess portion of the zip ties.

- Engage the (5) claws to install the **NEW** MGR connector cover.

HINT: Review the video for installing the MGR connector cover.

- Confirm that the FIPG extends around the circumference of the connector.



- g. Clean the connector housing to remove any excess FIPG remaining on the connector cover.

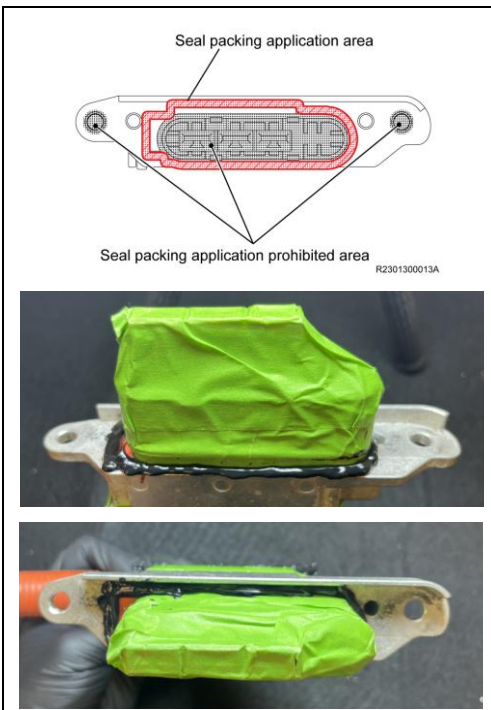

8. APPLY FIPG TO CONNECTOR MATING SURFACE

- a. Review the area that requires FIPG application.

FIPG_Application_Upper_Connect
or.MP4

- b. Fill FIPG into the gap of the connector mating surface as shown.

HINT: Review the video for the FIPG upper connector application.

NOTE: Be careful so the FIPG does not contact the bolt holes.

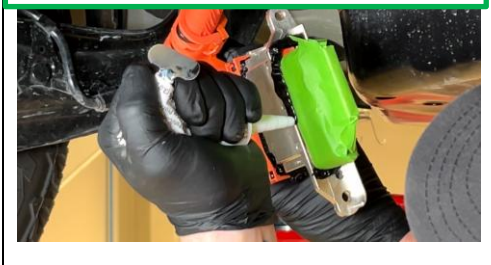

X. RETURN VEHICLE TO ITS ORIGINAL CONDITION

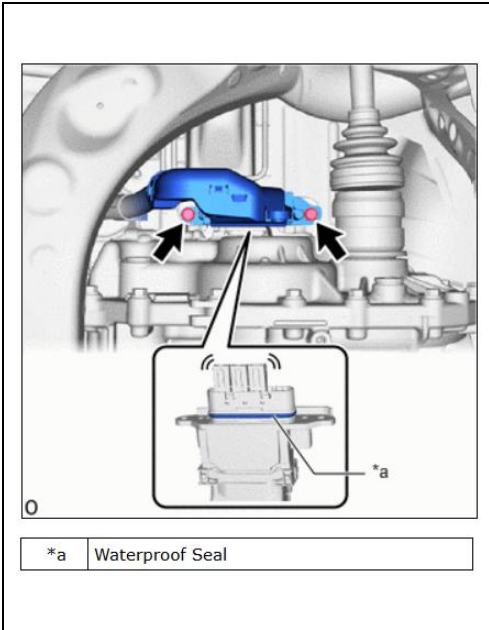

1. RECONNECT FLOOR UNDER WIRE

CAUTION: Be sure to wear insulated gloves.

- Install the (2) bolts and the HV floor under wire from the rear traction motor with transaxle assembly.

Torque:

8 N·m {71 in·lbf}

NOTE:

- Do not damage the terminals, interlock connector or rear traction motor with transaxle assembly during disconnection.
- Do not touch the waterproof seal or terminals of the connector.
- Do not allow any foreign matter or water to enter the rear traction motor with transaxle assembly.
- Although the connector may feel loose, this is not due to a malfunction.



- Smoothen out any excess FIPG that may have squeezed out during reinstallation.

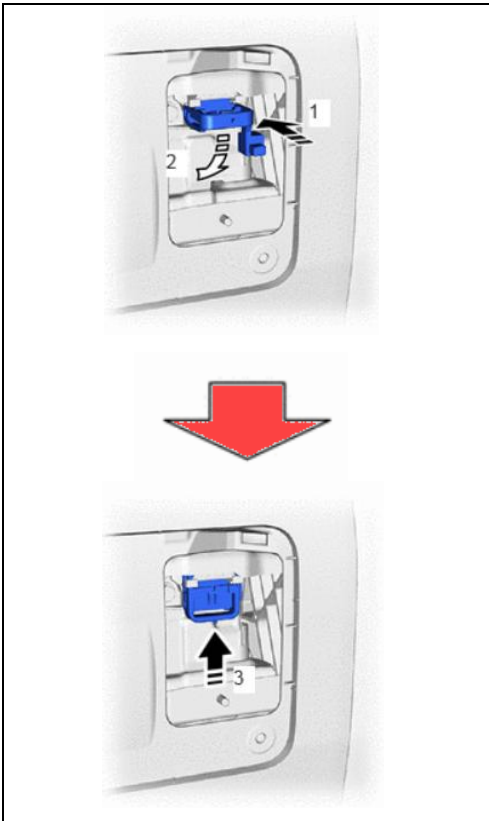

2. INSTALL SERVICE PLUG GRIP

NOTICE:

- Be sure to wear insulated gloves.
- Before installing the service plug grip, check that no parts or tools remain, and that the high voltage terminals and connectors are connected securely.

- Refer to the following Repair Manual link for the proper procedure:

HYBRID / BATTERY CONTROL: SERVICE PLUG GRIP: INSTALLATION:

- NX350h:** [2022-2024](#)
- NX450h+:** [2022-2024](#)
- RX350h:** [2023-2024](#)
- RX450h+:** [2024](#)

- While wearing insulated gloves, temporarily install the service plug grip as indicated by the arrow (1) in the illustration.
- Rotate the handle of the service plug grip 90° toward the HV battery and slide it in the direction indicated by the arrow (3) shown in the illustration until a click sound is heard to install the service plug grip.

◀ VERIFY REPAIR QUALITY ▶

- Confirm that the MGR connector is properly reinstalled.
- Confirm that the service plug grip is properly reinstalled.
- Confirm that the high-voltage system is properly restored.
- Confirm no DTCs are present after repair.

If you have any questions regarding this update, please contact your regional representative.

XI. APPENDIX

A. CAMPAIGN DESIGNATION DECODER

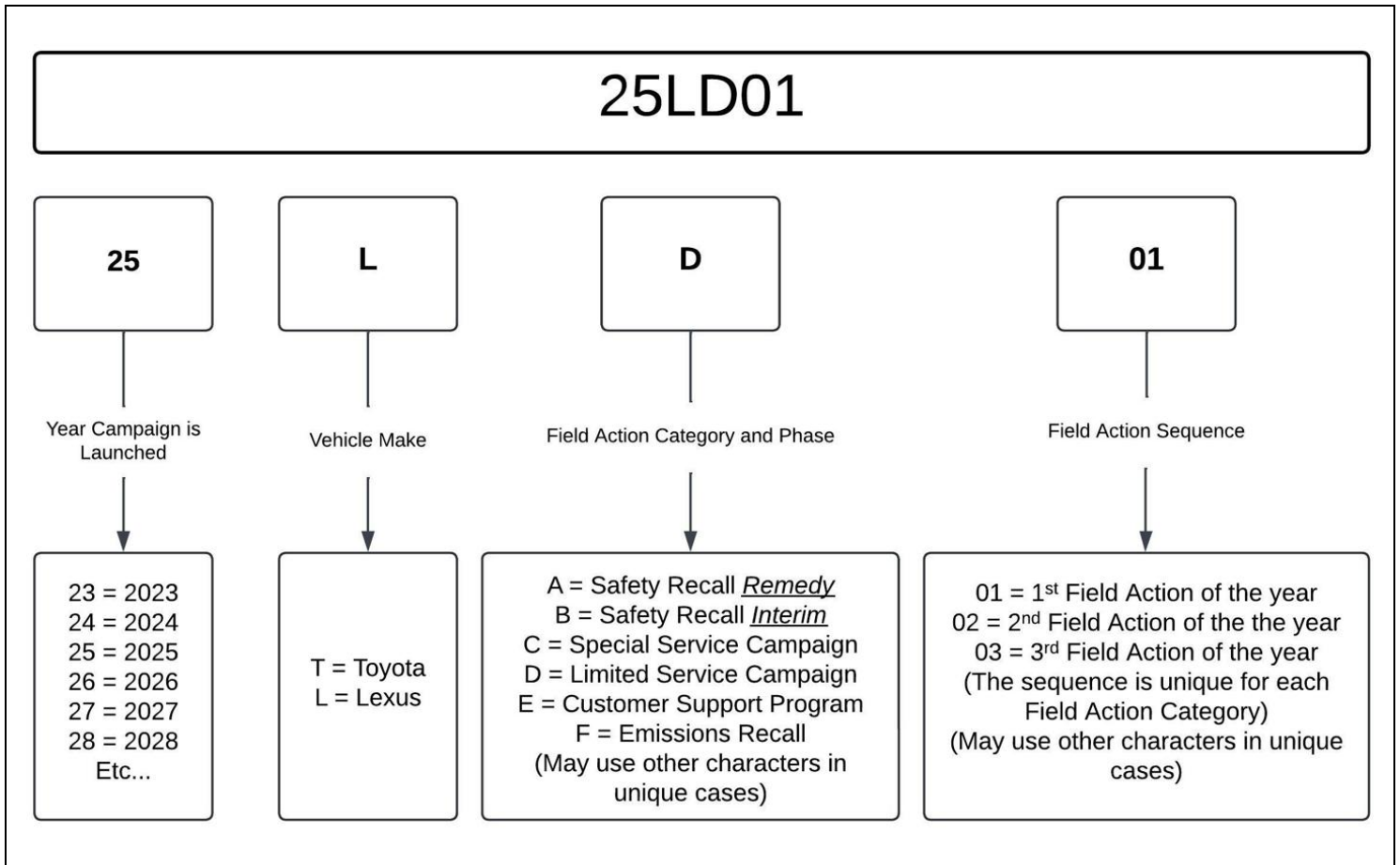

Examples:

19TA01 = Launched in 2019, Toyota, Safety Recall Remedy Phase, 1st Safety Recall Launched in 2019

20TC02 = Launched in 2020, Special Service Campaign, 2nd Special Service Campaign Launched in 2020

21TE05 = Launched in 2021, Customer Support Program, 5th Customer Support Program Launched in 2021

B. CAMPAIGN PARTS DISPOSAL

As required by Federal Regulations, please make sure all campaign parts (original parts) removed from the vehicle are disposed of in a way they will not be reused, **unless requested for parts recovery return.**