

Technical Information

FROM: Maserati TSO

TO: Maserati Network

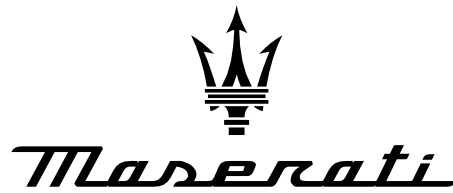

PERSONAL SERVICE LAB

MASTERS OF CARE

V6 Nettuno Engine Oil Pump Bearing Serviceability

DATE: September 16, 2025

This bulletin introduces the serviceability of the oil pump bearing on the V6 Nettuno engine. The bearing can now be replaced individually, eliminating the need for complete engine or long block replacement when noise is traced to this component.

Models Involved:

- Grecale V6 (All MY)
- GranTurismo V6 / GranCabrio V6 (All MY)
- MC20 / MC20 Cielo / MC20 Pura (All MY)

Condition

In some cases, engine noise has been traced to the oil pump bearing. For reference, **see the sample videos of a Grecale V6 included with this bulletin.**

Component Information

The following spare part is now available:

- **P/N 670050996 – Ball Bearing**
 - Spare Parts Catalogue → Section **01.61-1** → Component **24**.

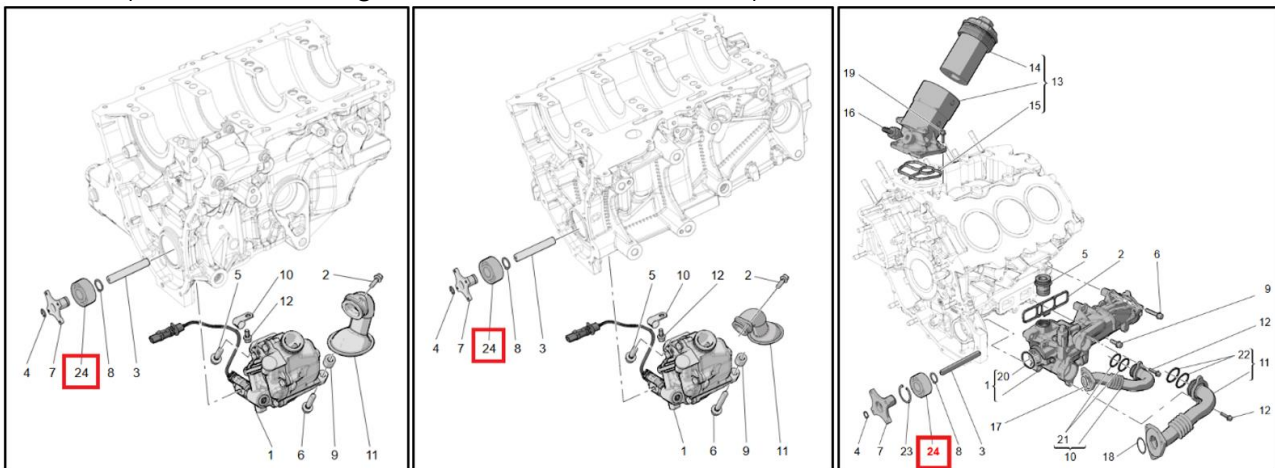

Grecale

GranTurismo

MC20

This part number applies to all models listed above. Always refer to the most recent **Technical Documentation** or contact the Maserati Helpdesk for updates.

Workshop Procedure (TechDocs)

The official replacement procedure is published in the Technical Documentation:

- **Procedure Reference:** #1.61.034 – Bearing for Complete Engine Oil Pump Control Unit

Special Tools

This procedure requires the following special tool:

- **P/N 900100036**

