



To: All Subaru Retailers
From: Subaru of America, Inc. – Service Quality
Date: September 12, 2025
Re: *WRD-25 Solterra HVAC ECU Reprogramming Safety Recall and Stop Sale – Stop Sale Procedure*

We are happy to provide an update regarding the WRD-25 25 Solterra HVAC ECU Reprogramming Safety Recall and Stop Sale.

The WRD-25 recall status for the 2023-2025 Solterra models included in the stop sale have been updated from “Open-Remedy not yet available” to “Open- Limited parts available.” Retailers should use the service procedure included at the end of this message to address in-stock stop sale units. **Coverage must be confirmed by using the Vehicle Coverage Inquiry function on subarunet.com prior to repair.**

The repair procedure outlined below is meant **only for stop sale vehicles in retailer inventory**. We will communicate additional information for the remaining affected vehicles in the coming weeks. Please be sure to review the service procedure in its entirety. It is imperative that the technician is aware of the production date of the vehicle in order to understand the proper repair procedure for an affected stop sale vehicle.

This repair procedure will also be available on STIS later in the day on Friday, 9/12. In the rare instance that an affected vehicle requires a compressor kit, the vehicle will remain on HOLD until recall remedy parts are available.



Once we have sufficient parts available, the VIN status for the remaining recall population will be updated to allow repairs to begin. Retailers will be notified when this update occurs.

STOP SALE SERVICE PROCEDURE INFORMATION

IMPORTANT: The repair procedure outlined below is meant **only for stop sale vehicles in retailer inventory**. We will communicate additional information for the remaining affected vehicles in the coming weeks.

PART INFORMATION:

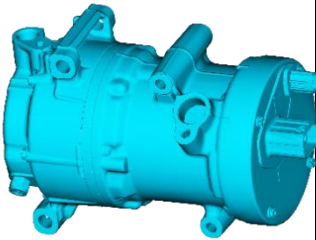
A part kit for vehicles requiring electrical compressor replacement is currently in development. Information regarding order placement will be provided once made available.

Part Name		Part Number	Qty	Details
WRD-25 COMPRESSOR KIT		0400530242	1	-
①	COMPRESSOR ASSY, W/M	-	1	
②	RECEIVER ASSY	-	1	
③	O-RING	-	2	O-RING Dimensions ID : 13.4mm / OD : 18.2mm
④	O-RING	-	2	O-RING Dimensions ID : 17.2mm / OD : 22.0mm
⑤	O-RING	-	3	O-RING Dimensions ID : 10.8mm / OD : 15.6mm
⑥	O-RING	-	2	O-RING Dimensions ID : 6.7mm / OD : 10.3mm



.CUW FILE INFORMATION:

The following files can be located in the ECU Data folder within the TechStream files located on the Subaru Desktop.





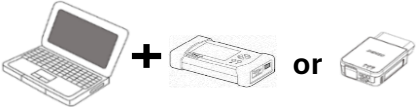

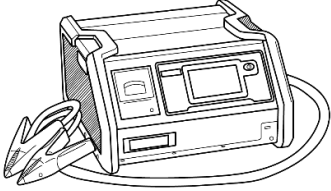



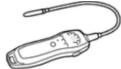

MY	File Description	Target CID	New CID
23	NA(23MY)_8865F4216000.cuw	8865F42 13100	8865F42 16000
24-25	NA(24-25MY)_8865F4228100.cuw	8865F42 220A0 or 8865F42 28000	8865F42 28100

REQUIRED TOOLS FOR REPROGRAMMING:

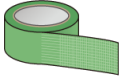
Tool Description	Applications	Image
Laptop DST-i or DST-010	For DTC inspection and Reprogramming	
GTS+		
< MIDTRONICS > DCA-8000	Required to maintain battery voltage during the reprogramming procedure	

REQUIRED TOOLS FOR A/C COMPRESSOR REPLACEMENT (IF REQUIRED):

Tool Description	Applications	Image
Refrigerant Recovery and Filling Device (compatible with 1234yf)	For air conditioner gas recovery and refilling	
Air conditioner gas leak tester	Inspect for refrigerant leak	
Insulated Tool Set and Insulated Gloves	For working with high-voltage components	

Circuit Tester	For checking voltage	
Insulating tape	For connector protection	
Protective Tape	For protecting parts	
Torque Socket Wrench E8	For removing / installing compressor	
Cable Tie	For holding parts (20-30cm)	
Cloths	For cleaning	
Protective Equipment	For protecting hands and eyes	
General Tools	For work purposes	
Torque Wrench	Check tightening torque	

SERVICE PROCEDURE FLOW CHART:

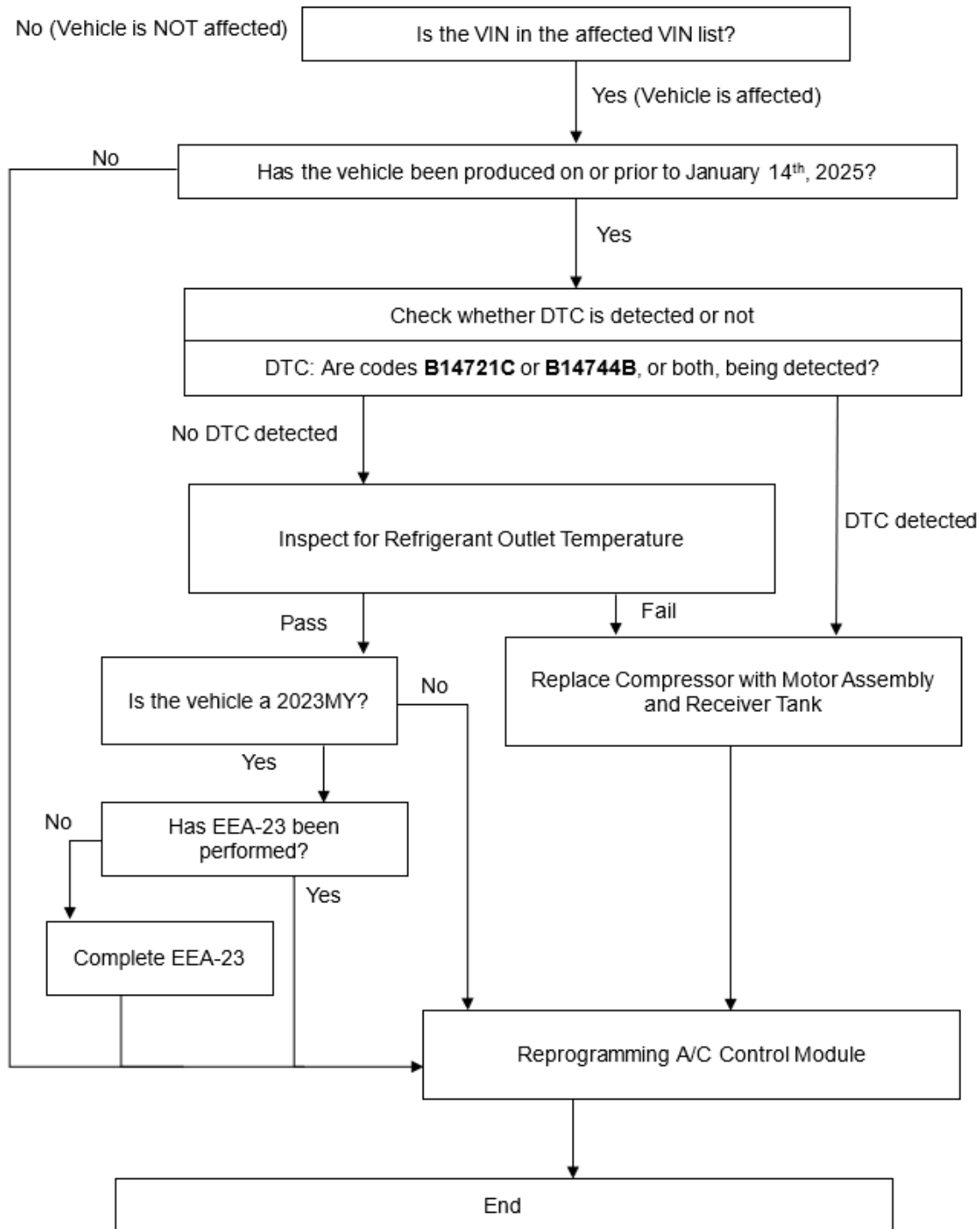

NOTE: PRIOR to attempting any reprogramming, complete all required inspection and where necessary related repairs outlined in the above flow chart. 2023MY vehicles MUST require the software outlined in EEA-23 to be installed prior to reprogramming. ALWAYS confirm the target CID prior to reprogramming. When necessary, install the EEA-23 update before attempting to install the WRD-25 software.

COMPONENT LOCATION:

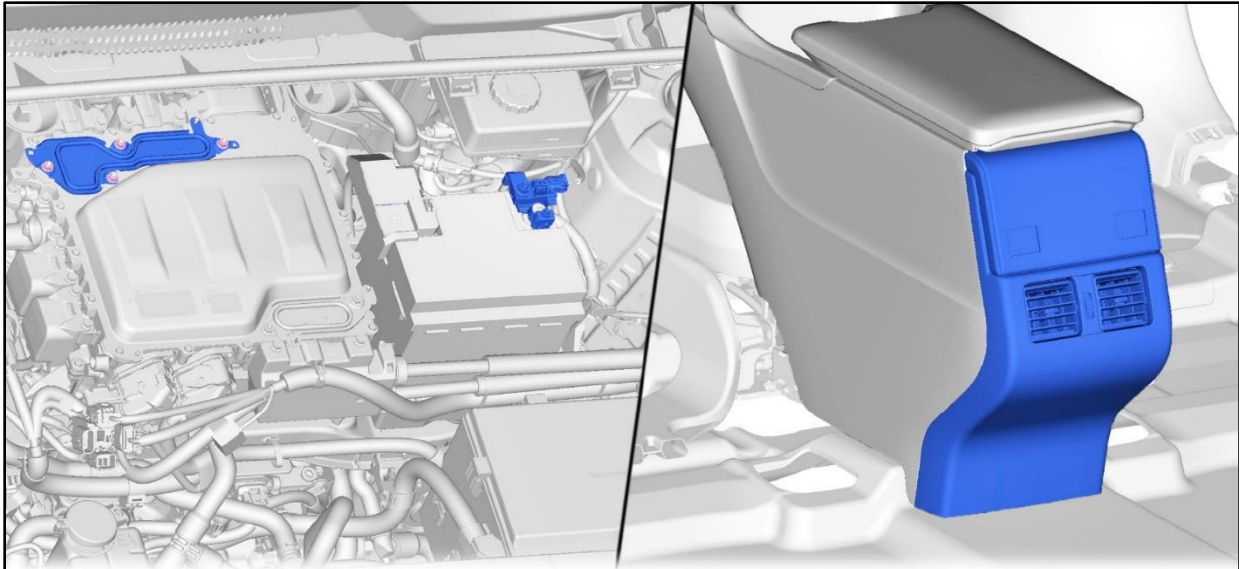

NEGATIVE AUXILIARY
BATTERY TERMINAL

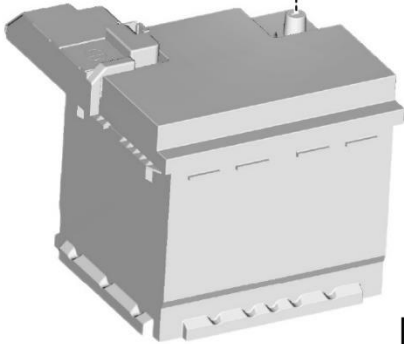

NO. 2 TERMINAL COVER

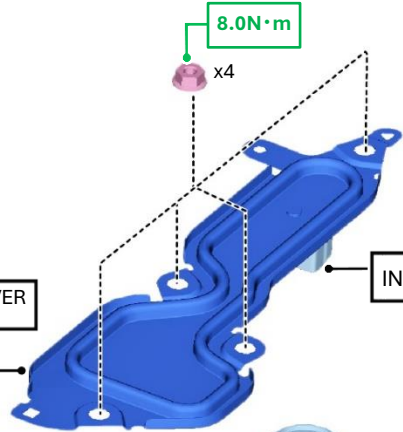

INTERLOCK



SERVICE PLUG GRIP



CONSOLE REAR END PANEL SUB-ASSEMBLY

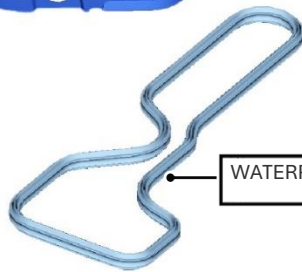

WATERPLOOP SEAL

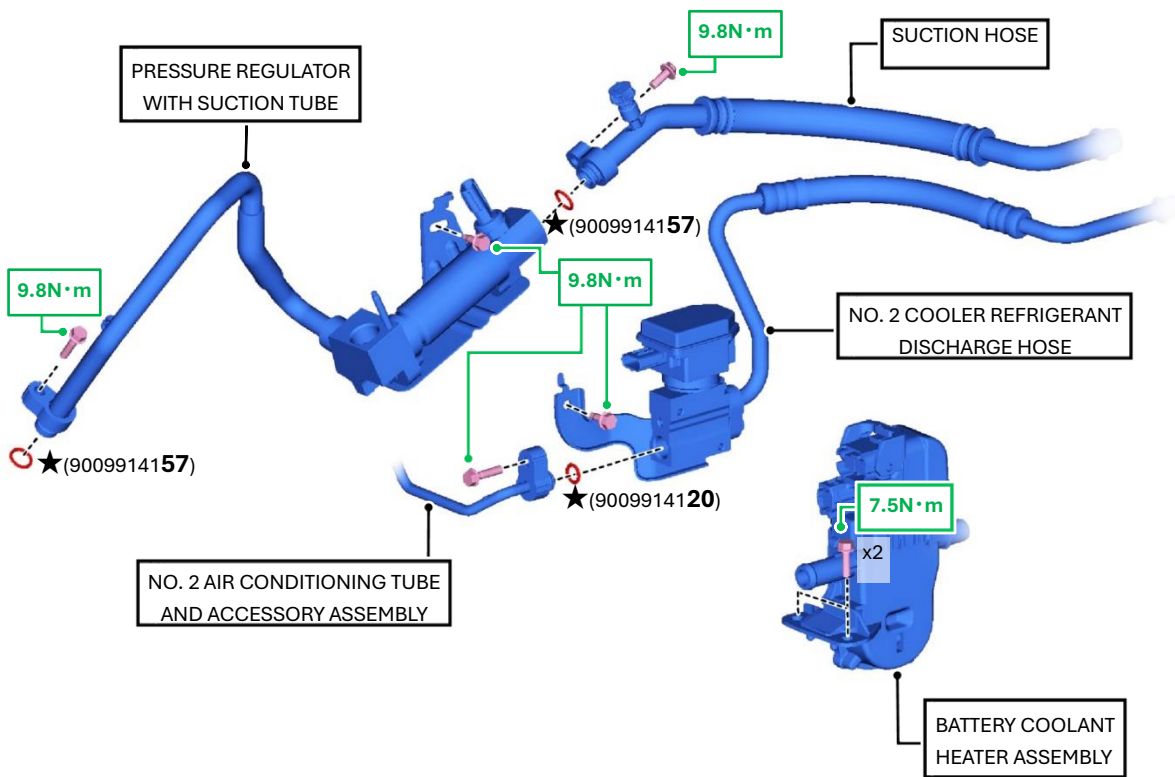
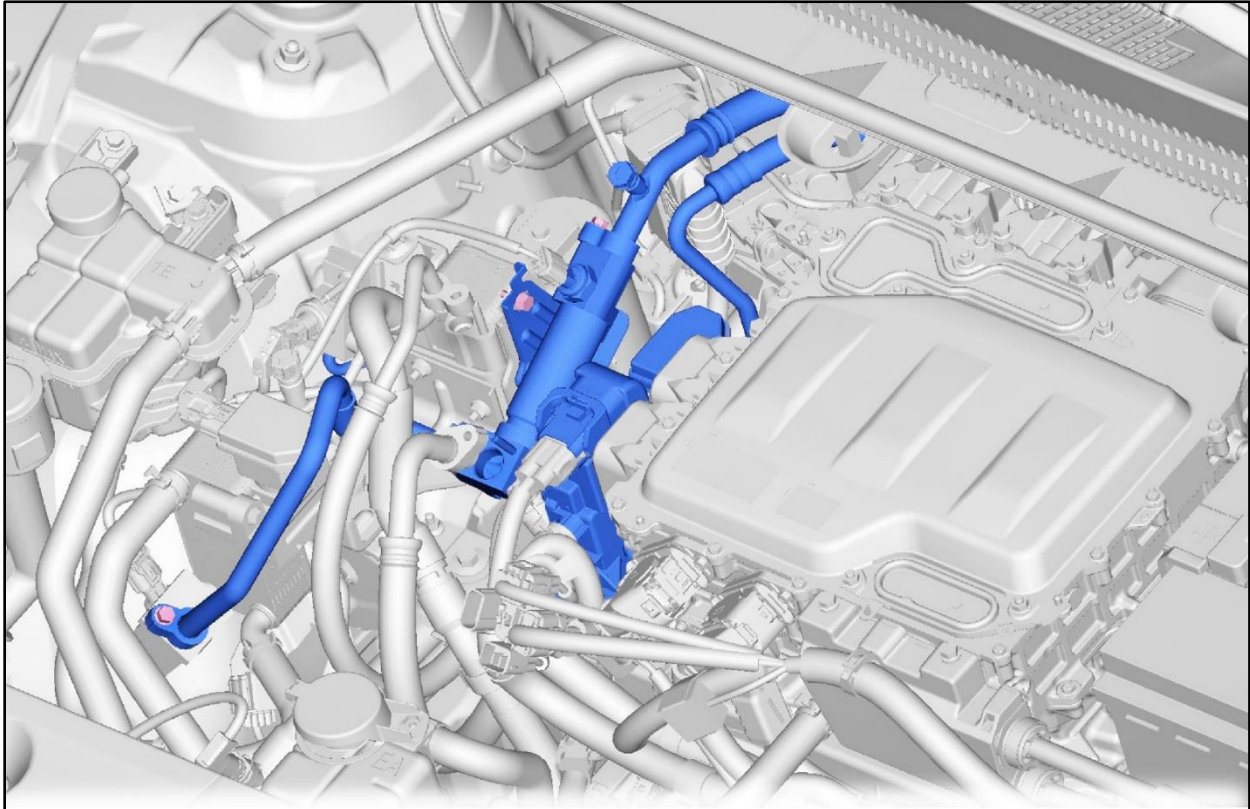

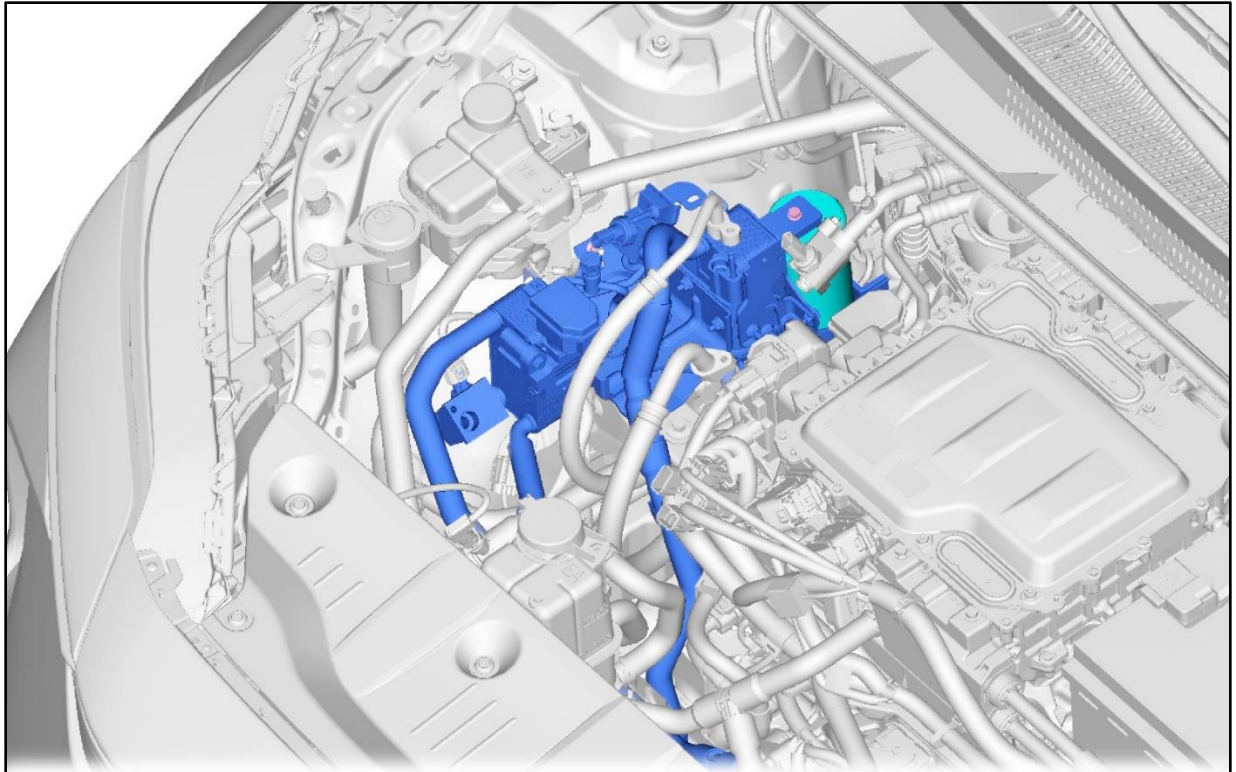

CONDENSER ASSEMBLY WITH
HEAT EXCHANGER UNIT SUB-ASSEMBLY

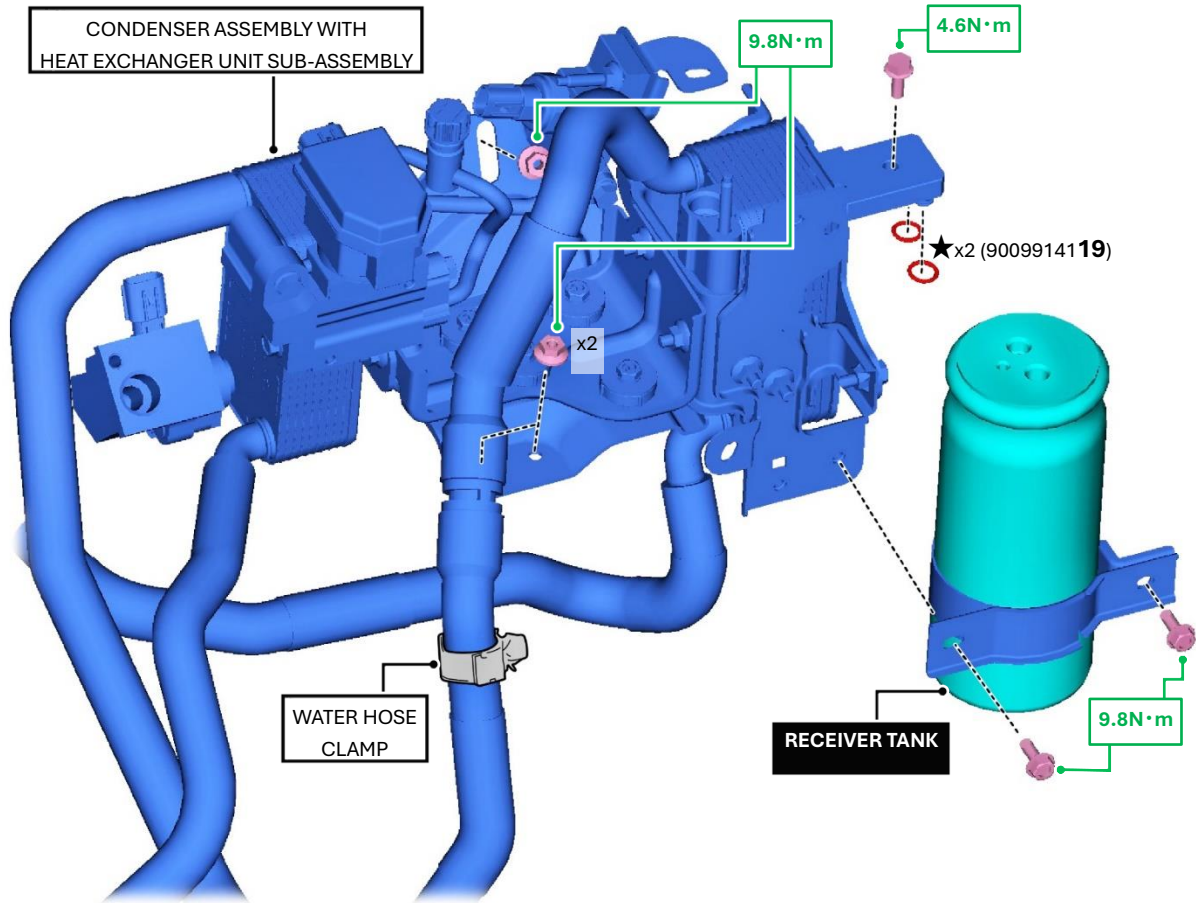

SERVICE PROCEDURE:

STEP 1: Has the vehicle been produced prior to January 14, 2025? This can be confirmed by the vehicle inquiry.

YES: Proceed to Step 2.

NO: Proceed to Step 17.

STEP 2: Perform a Health Check using GTS+. Check for any faults detected by the Air Conditioner system. Refer to the table below to confirm the next course of action.

JUDGMENT CRITERIA		
<p>Are any or both of the following DTCs current or stored?</p> <p>DTC : B14721C (A/C Inverter High Voltage Output Circuit Voltage Out of Range)</p> <p>DTC : B14744B (A/C Inverter Cooling/Heating Over Temperature)</p>		
Inspection Result		Next Step
NO	No DTC detected	Proceed to the next step.
YES	DTC detected	TBD until part supply becomes sufficient.

STEP 3: Confirm the ignition switch is “READY ON”. Check the status of the ambient temperature displayed on the instrument cluster. This temperature will confirm the A/C settings for the required inspection mode performed in the next step.

Outside Temperature	Inspection Mode
Below 77°F (25°C)	A/C OFF
77°F (25°C) or above	A/C ON

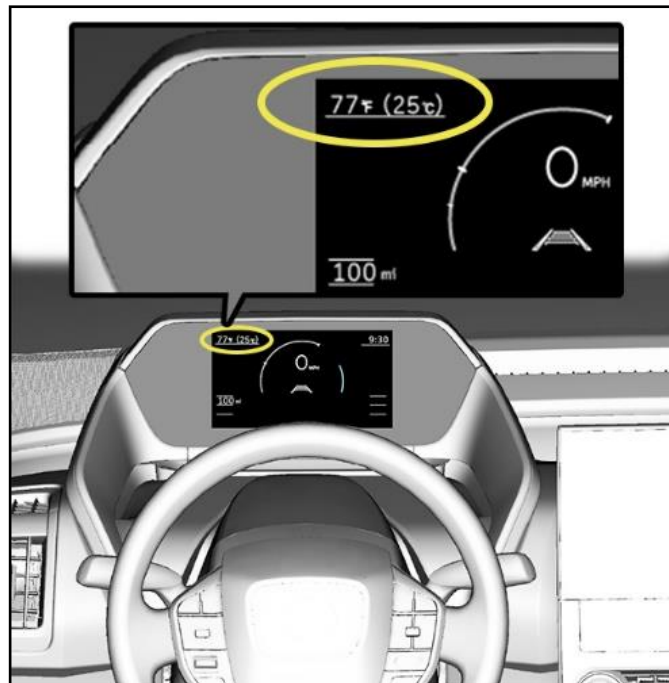

STEP 4: Using the result from the previous step, confirm and apply the A/C settings required for the inspection mode.

Below 77°F (25°C) (Inspection Mode : A/C OFF)		A/C Settings	77°F (25°C) or above (Inspection Mode : A/C ON)	
ON * After operating to FOOT mode, the indicator turns off.		AUTO		ON * After operating to FOOT mode, the indicator turns off.
OFF		A/C		ON
FOOT		Airflow mode control		FOOT
OUTSIDE		Outside/recirculated air mode		INSIDE
MAX HOT		Temperature control (Both drivers and passenger seat)		MAX HOT
DO NOT TOUCH	/	Fan Speed	/	DO NOT TOUCH
OFF		ECO		OFF
ON		SYNC		ON
OFF		S-FLOW		OFF
READY ON	/	Ignition Switch	/	READY ON
CLOSE ALL	/	Window / Door	/	CLOSE ALL

NOTE: If you change the Airflow mode control to FOOT after operating the AUTO switch, the AUTO switch operation indicator light will turn off, but you will need to operate the AUTO switch to operate the Fan Speed with automatic setting.

CAUTION:

- Confirm the correct A/C settings are applied to confirm an accurate inspection.
- Even if the A/C indicator is off, the A/C may still be operating. If you need to turn it off, first turn the A/C on and then turn it off.
- Even if the displayed temperature is below 77°F (25°C), if the vehicle protection control indicates a situation where the actual rotation remains at 0 rpm and below 1000 rpm for 30 seconds after the active test shows 5200 rpm, perform the A/C under conditions of 77°F (25°C) or higher.
- **DO NOT** perform any reprogramming prior to performing the inspection mode. The new software will cause inaccurate results.

STEP 5: Using the GTS+, click on “Air Conditioner” located in the “System Select” column.

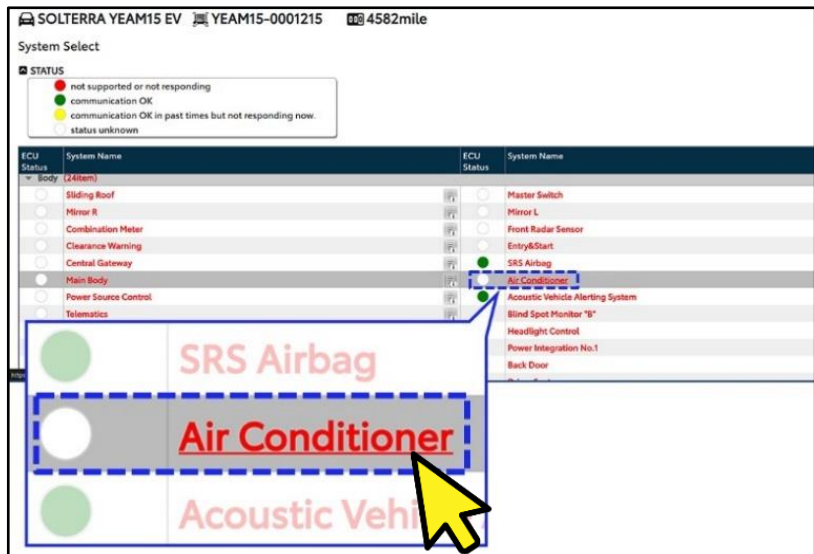

STEP 6: Click on “Active Test” and “Compressor Target Speed”. Click the “Next” button to continue.

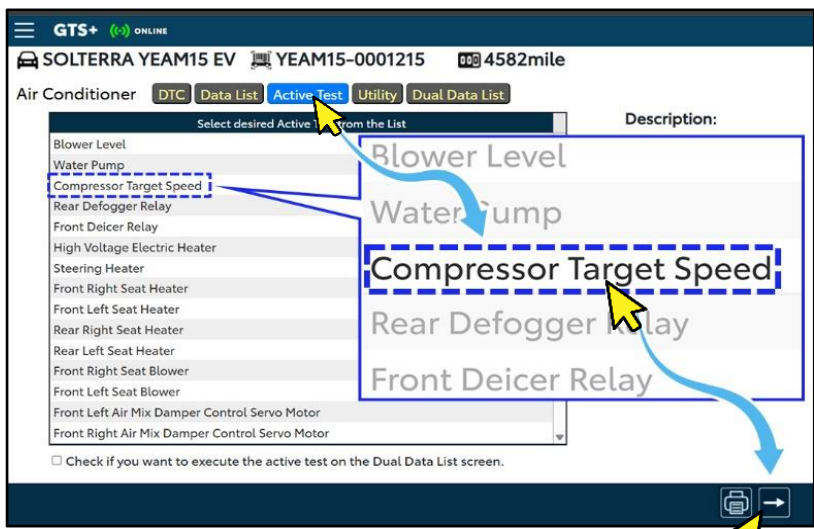

STEP 7: Using the adjustment buttons, set the compressor target speed to **5200**.

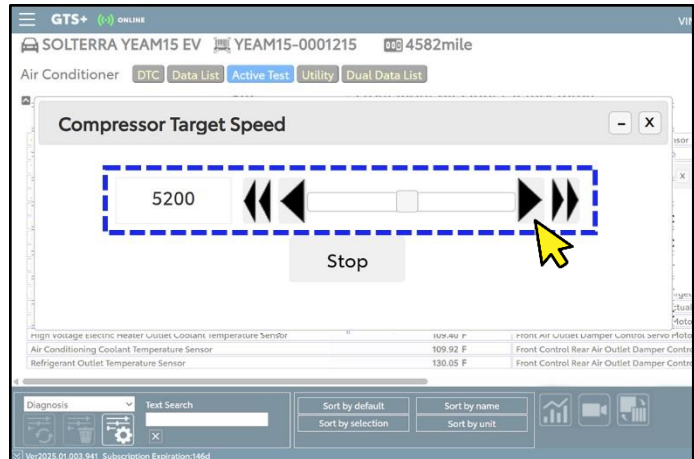

STEP 8: Select the item from “Diagnosis” to “All Data”.

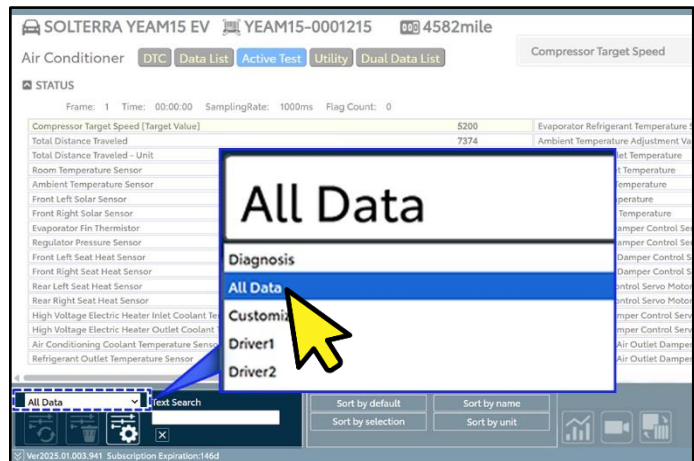

STEP 9: Select “Refrigerant Outlet Temperature Sensor” & “Compressor Actual Speed” then click the “Graph” button to continue.

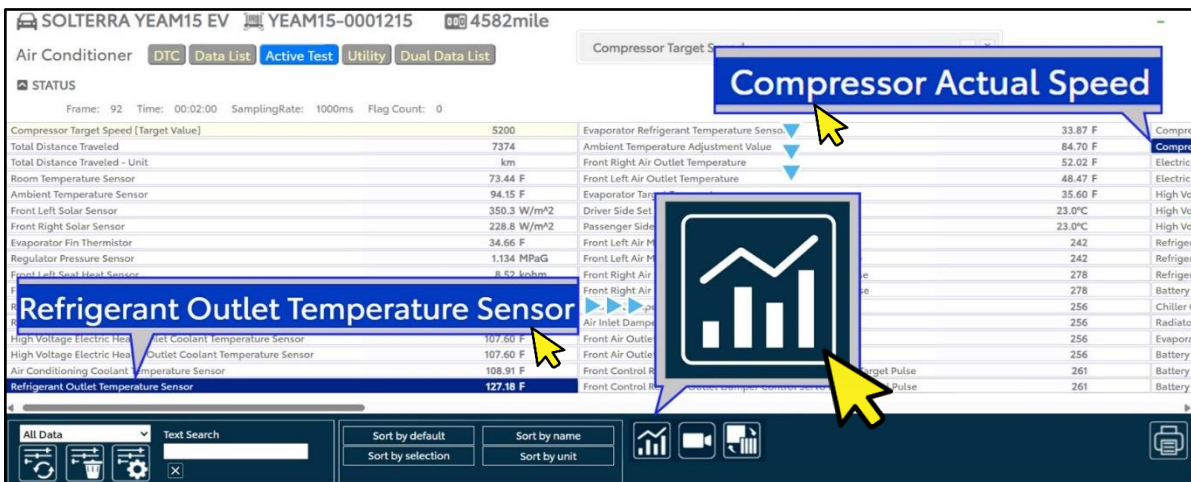

STEP 10: Click the “Snapshot” button then click the “Snapshot Configuration” button. Set the duration to ten minutes. Click the “OK” button to continue.

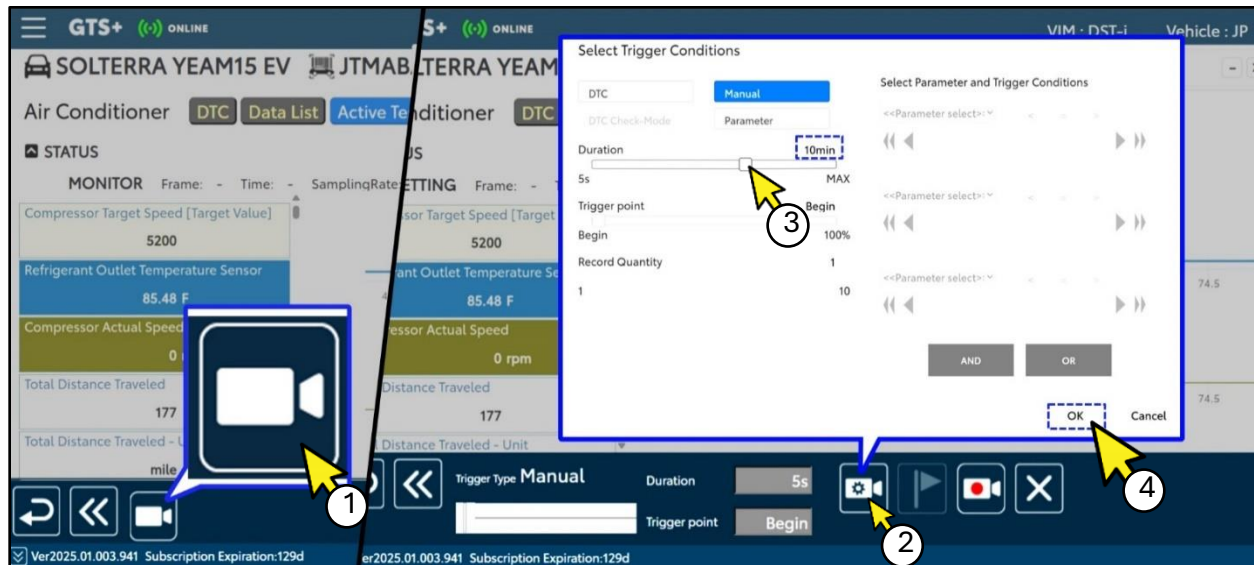

1. Snapshot Button
2. Snapshot Configuration Button
3. Duration Adjustment
4. OK Button

STEP 11: Click the “Record” button. Allow the ten minute recording to begin. Allow the ten minute time period for recording.

CAUTION: If the outside temperature displayed on the meter is below 77°F (25°C) and the inspection mode is set to "Air Conditioner OFF," check the "Actual Electric Compressor RPM" again before recording. If it is still within the 0-1000 rpm range after 30 seconds, switch the inspection mode to "Air Conditioner ON," just as if the temperature were 77°F (25°C).

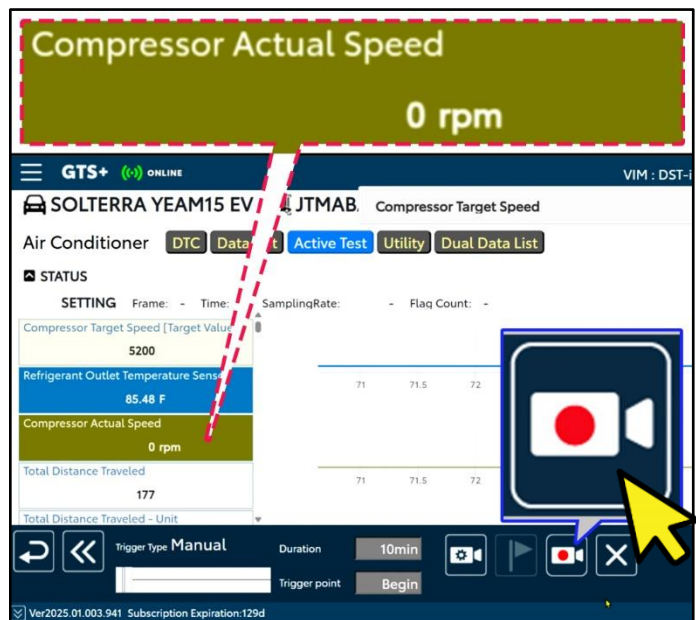

NOTE: If the graph does not appear, click the graph setting icon and change the Y-axis to "AUTO".

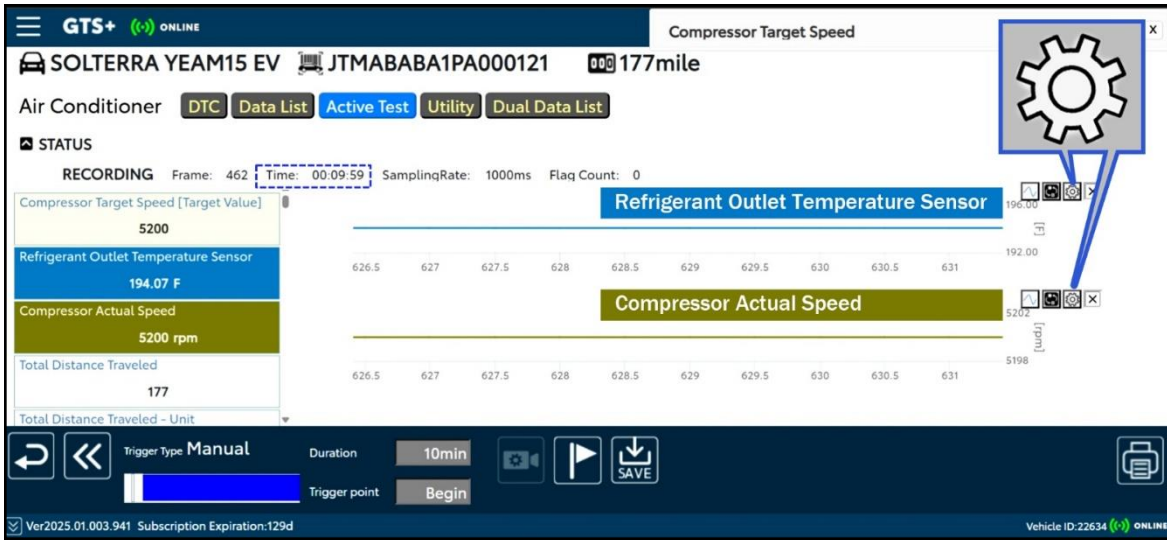

STEP 12: After the ten minute recording has been completed, a pop-up will display asking if the data is to be saved. Click "Yes", select a destination for the data, and click "OK". Once saving is completed, click "OK" to continue.

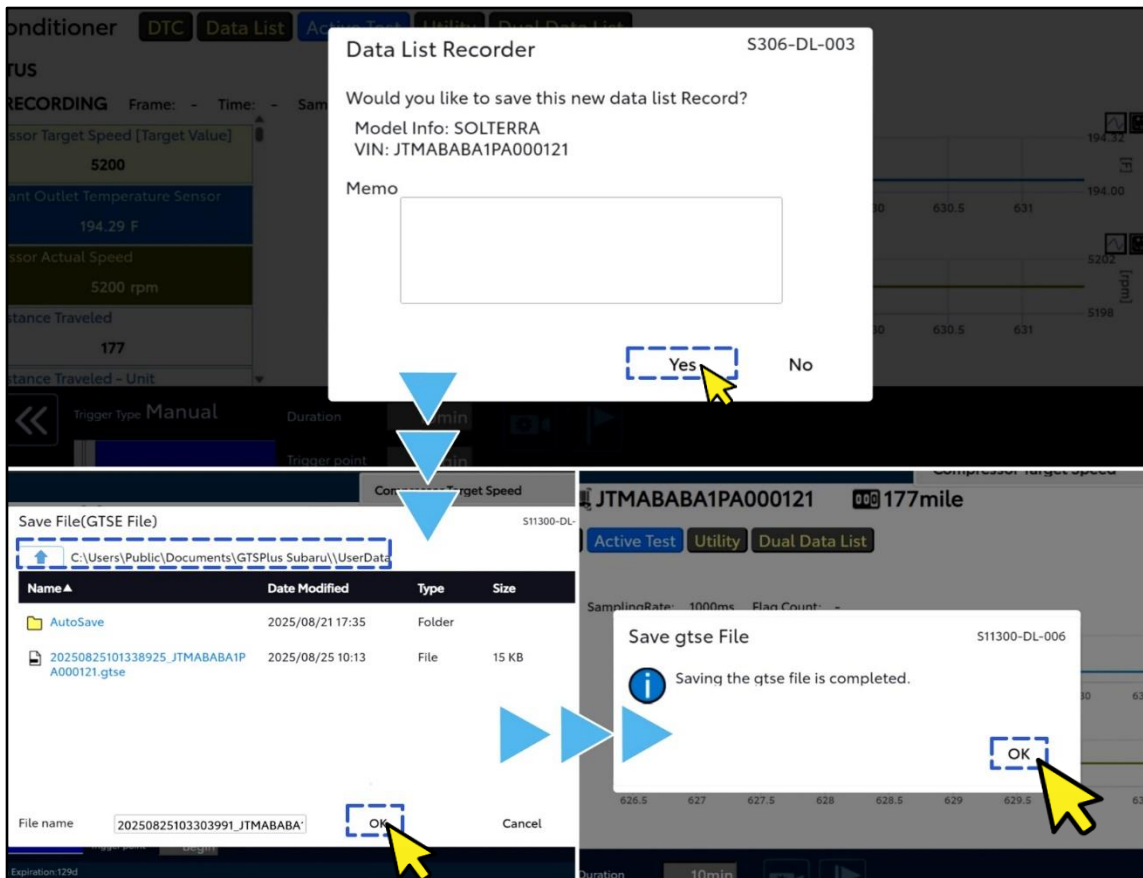

STEP 13: Select “Exit to Home” located in the top left corner of the GTS+ application. The home screen will then be displayed. Select the “Open Scan Data File” icon.



Select the saved file and click “OK” to continue.

NOTE: The file size, date, and time can help ensure the correct file is selected.

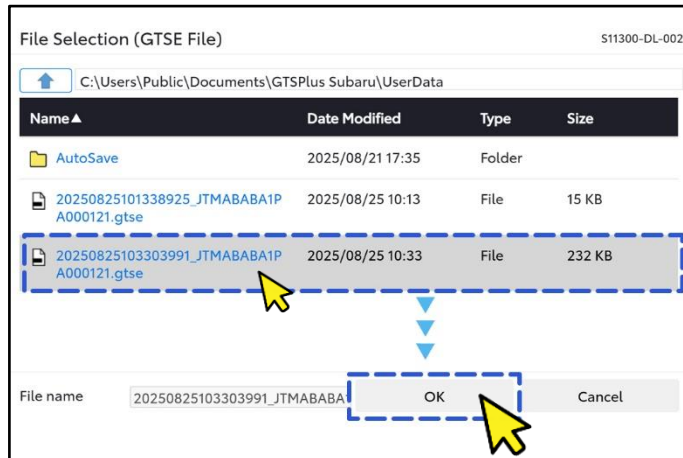

STEP 14: Click the file icon located in the upper left corner. Open “Air Conditioner” and then “Active Test”. Click the saved data.

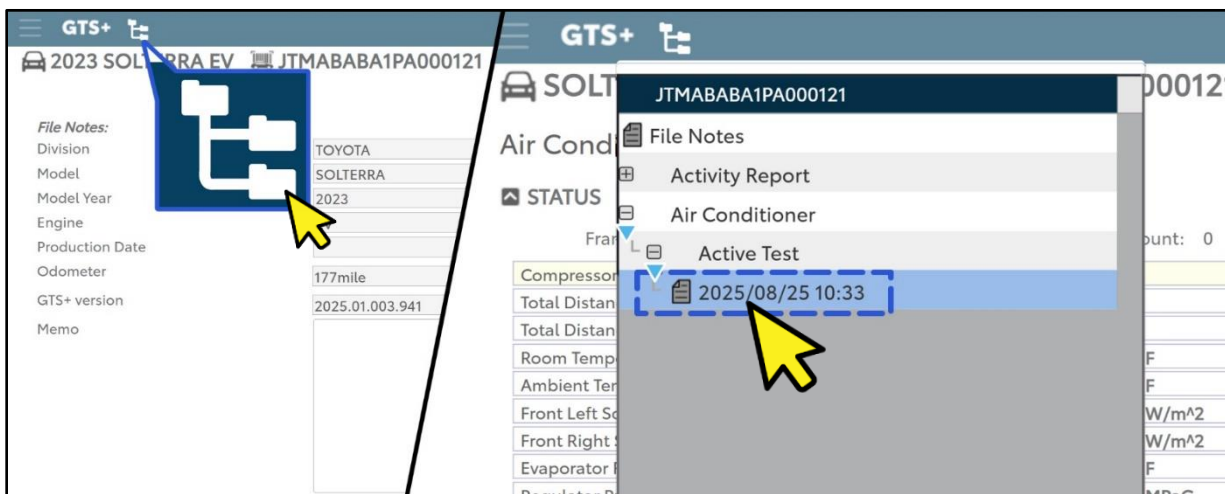

STEP 15: Select “Refrigerant Outlet Temperature Sensor” and then click the “Graph” button. This will allow the ten minute recording to be viewed.

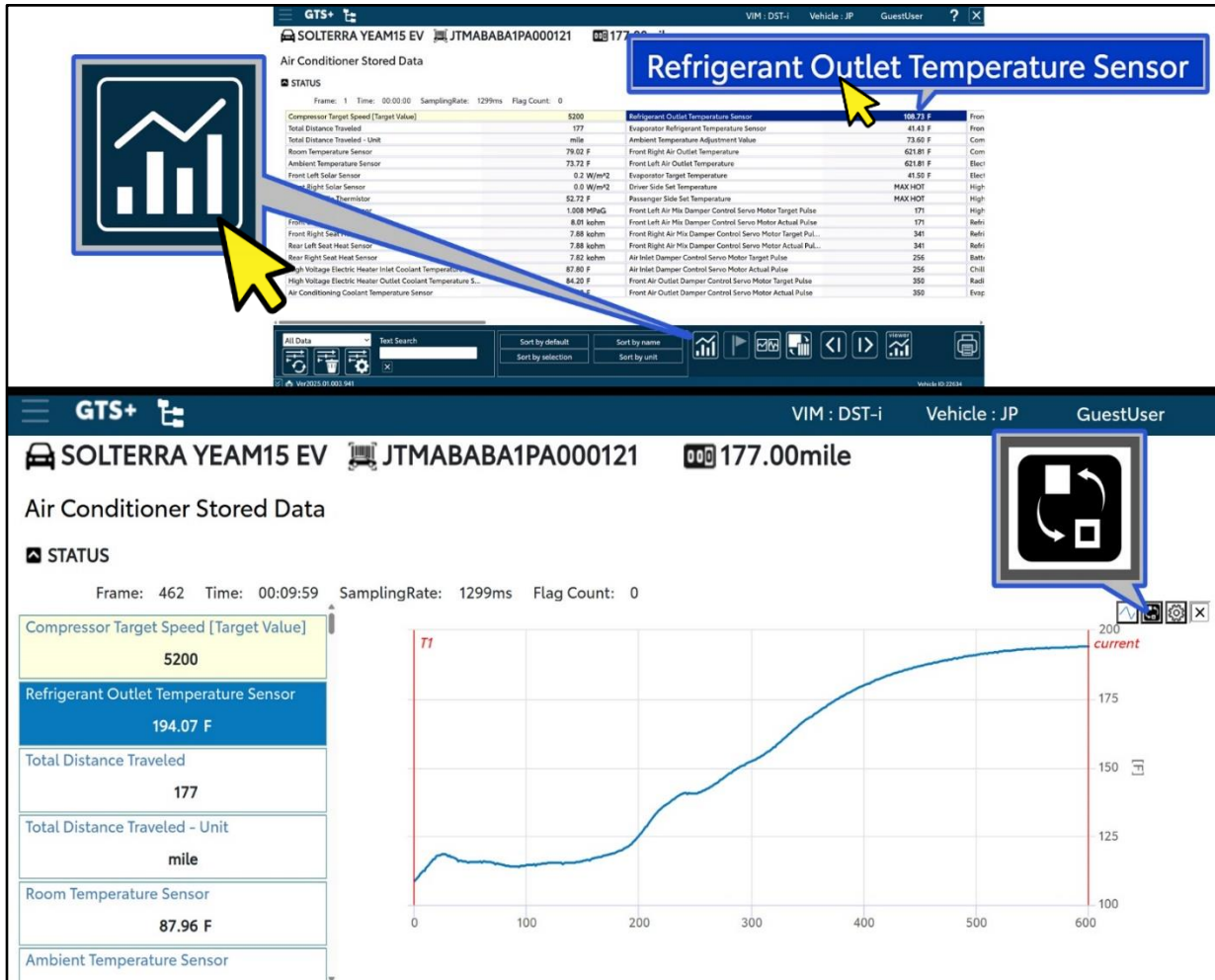

NOTE: If the outside temperature is under 77°F (25°C) and the inspection mode is A/C OFF, click " Change graph" and change the display format to "Meter" to make it easier to determine the maximum temperature.

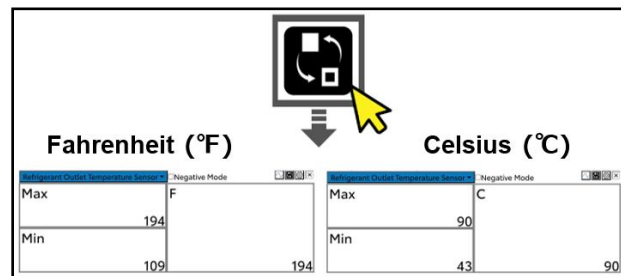

STEP 16: Check the refrigerant outlet temperature and determine if the compressor requires replacement. Refer to the tables below.

CAUTION: The method for checking data differs depending on the inspection mode with the A/C on or off. This selection is based on the ambient air temperature confirmed in step 3.

JUDGMENT CRITERIA

Inspection Mode	Inspection Method
<p>77°F (25°C) or above</p> <p>A/C ON</p>	<p>Confirm Refrigerant Outlet Temperature after 5 to 10 minutes.</p>

Did the Refrigerant Outlet Temperature reach 230°F (110°C) after 5 to 10 minutes?

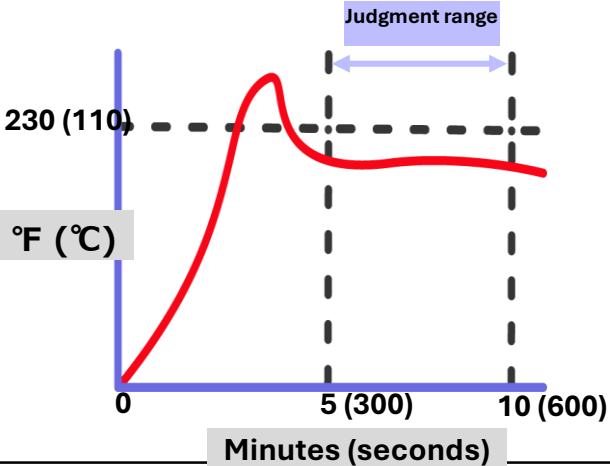
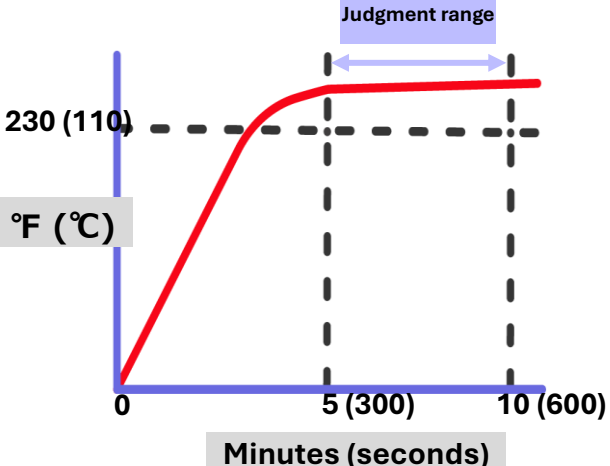
Inspection Result	Next Step
<div style="background-color: #00b050; color: white; text-align: center; font-size: 2em; font-weight: bold; padding: 20px;">NO</div> <p style="text-align: center; color: green; font-weight: bold;">After 5-10 minutes the temperature never reached 230°F (110°C).</p>  <p style="text-align: center;">Minutes (seconds)</p>	<p style="font-size: 1.2em; font-weight: bold;">Proceed to Step 17</p>
<div style="background-color: #ff0000; color: white; text-align: center; font-size: 2em; font-weight: bold; padding: 20px;">YES</div> <p style="text-align: center; color: red; font-weight: bold;">After 5-10 minutes the temperature was over 230°F (110°C).</p>  <p style="text-align: center;">Minutes (seconds)</p>	<p>TBD until part supply becomes sufficient.</p>

JUDGMENT CRITERIA

Inspection Mode	Inspection Method	
Below 77°F (25°C) A/C OFF	Confirm Refrigerant Outlet Temperature for 10minutes.	
At any time during the 10 minute inspection did the Refrigerant Outlet Temperature reach 239°F (115°C)?		
Inspection Result	Next Step	
NO	<p style="color: green; text-align: center;">The temperature never reached 239° (115°C) F in 10 minutes.</p>	<p style="font-size: 1.2em; font-weight: bold;">Proceed to Step 17</p>
YES	<p style="color: red; text-align: center;">Within 10 minutes the temperature reached 239°F (115°C).</p>	<p>TBD until part supply becomes sufficient.</p>

STEP 17: Reprogram the Air Conditioning Control Unit using the normal GTS+ reprogramming procedures and applicable file listed below. See TSB 14-30-24R for further details regarding GTS+ reprogramming.

CAUTION: DO NOT perform any reprogramming prior to performing the inspection mode. The new software will cause inaccurate results.

MY	File Description	Target CID	New CID
23	NA(23MY)_8865F4216000.cuw	8865F42 13100	8865F42 16000
24-25	NA(24-25MY)_8865F4228100.cuw	8865F42 220A0 or 8865F42 28000	8865F42 28100

NOTE: 2023MY vehicles MUST require the software outlined in EEA-23 to be installed prior to reprogramming. ALWAYS confirm the target CID prior to reprogramming.

CLAIM INFORMATION:

Solterra HVAC ECU Reprogramming ONLY			
Labor Description	Labor Operation #	Fail Code	Labor Time
A/C ECU Reprogramming Only	A180-555	WRD-25	0.7

Solterra HVAC ECU Programming & Compressor Inspection			
Labor Description	Labor Operation #	Fail Code	Labor Time
Reprogramming & DTC Check, and Compressor Check	A170-600	WRD-25	1.2
Reprogramming & DTC Check, Compressor & Receiver Replacement	A170-601	WRD-25	4.0
Reprogramming & DTC Check, Compressor Check, and Compressor & Receiver Replacement	A170-602	WRD-25	4.3

IMPORTANT REMINDERS:

- SOA strongly discourages the printing and/or local storage of service information as previously released information and electronic publications may be updated at any time.
- Always check for any open recalls or campaigns anytime a vehicle is in for servicing.
- Always refer to STIS for the latest service information before performing any repairs.

SERVICE PROGRAM IDENTIFICATION LABEL:

Type or print the necessary information on a Campaign Identification Label. The completed label should be attached to the vehicle's left side radiator support bracket located behind the driver side headlamp. Additional labels are available through normal parts ordering channels. The part number is **MSA6P1302**, which comes as one sheet of 20 labels.

Part Number	Applicability	Description	Order Quantity
MSA6P1302	All Models	Campaign Completion Labels (contains one sheet of 20 labels)	1

SUBARU
Campaign Code
WRD-25
COMPLETED
DIST./DEALER NO.
SERIAL NO.
DO NOT REMOVE