

**Diagnostic Sheet**

FROM: Maserati TSO

TO: Maserati Network



**Maserati**

PERSONAL SERVICE LAB

MASTERS OF CARE

# HVAC DIAGNOSTIC WORKSHEET



**IMPORTANT NOTICE** This bulletin supersedes MAS004757 DS 25-16 released on May 30, 2025. It contains updated information, please ensure all previous versions are discarded.

DATE: SEPTEMBER 05, 2025

This Diagnostic Sheet serves as a guide and provides a diagnostic path to help determine the root cause of certain HVAC concerns. **This Diagnostic Sheet requires a BOL to be submitted.**

**MODELS:** Grecale, GT/GC, MC20 (All MY)

**WHEN DEALING WITH HVAC CONCERNS SUCH AS “AC NOT BLOWING COLD,” DO NOT ASSUME IT IS DUE TO LOW REFRIGERANT. DO NOT EVAC AND RECHARGE THE HVAC SYSTEM UNTIL ADVISED TO DO SO BY THE BOL TEAM!**

Perform and complete the inspection procedures starting on the next page. Once completed. Open a BOL “Support Request”, report all results, and attach pages 2 and 3 along with all EVO reports.

If any of the below information is missing, Maserati reserves the right to request it before providing support/approval or feedback to Blue On Line. Maserati reserves the right to deny coverage for repairs not performed to factory standards. For additional questions or support, please contact Maserati Technical Service Operations.

# DIAGNOSTIC PROCEDURES

## A) General HVAC Pre-diagnostic Inspections

1. Perform a walk-around visual inspection of the vehicle exterior for damage, especially the front bumper and grill for condenser damage, and the driver-side mirror where the ambient sensor is located.
2. Perform a visual inspection of the engine bay, air vents, and Cabin Filter. Check the outside recirc vents for debris. Inspect the accessory belt, AC compressor, all related lines, and fittings for issues.

## B) HVAC STATIC and DYNAMIC performance inspections

1. Run the engine at IDLE until fully warmed up. While the engine is running, create a DTC and Parameter report in PDF format of the following modules: **ECC, ECM, BCM, ICS, and (ICS-R if equipped)**.

### STATIC PERFORMANCE INSPECTION

This test is essential for evaluating the **resting (static) pressures** of the A/C system and provides a baseline for diagnosing potential refrigerant-related issues.

1. What is Shop Ambient Temp during the test above? \_\_\_\_\_
2. What is Shop Ambient Humidity during the test above? \_\_\_\_\_
3. With the engine OFF for a minimum of 15 minutes (To allow pressures to equalize), hook up your HVAC manual gauges and document LOW and HIGH side pressures (Take a picture of gauges (High and Low) and attach it to BOL and Label "ENGINE OFF – PRESSURES")

### DYNAMIC PERFORMANCE INSPECTION

This test is essential for evaluating **real-time system performance under load**, ensuring that the air conditioning system is functioning within manufacturer specifications.

**The following tests must be performed with all doors closed and windows rolled up.**

1. Start the vehicle up and let the engine run at IDLE, then set the HVAC to the following:
  - a. AC: MAX ON
  - b. MODE: Center Dash Vents
  - c. Blower: MAX
  - d. TEMP: LOW (Dr. and Pass. sides)
  - e. AUTO: OFF

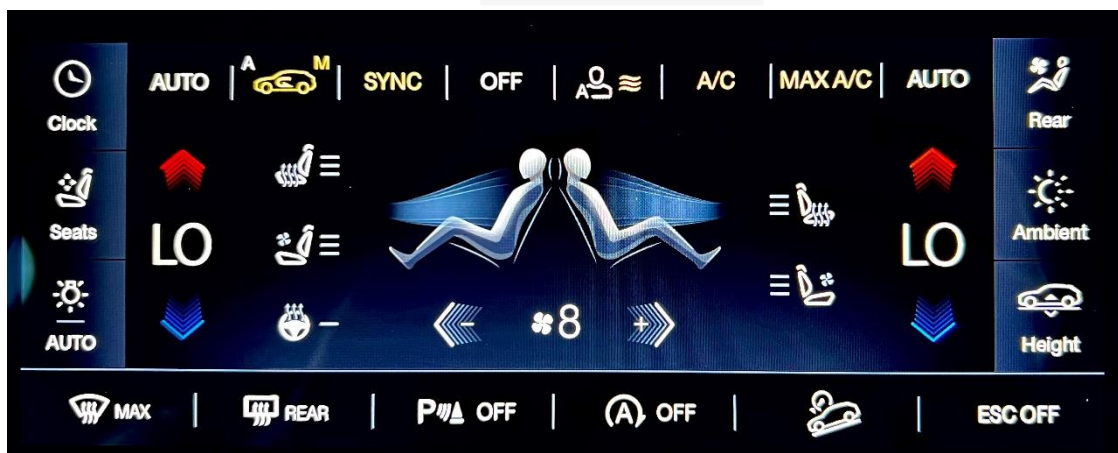

2. Wait 5 minutes and then use the EVO to run a report of the **BCM, ECM, and ECC modules**. PARAMETERS & DTCS and SAVE as PDF then Attach to BOL.
3. Place a DIGITAL Temp Gauge in the Dash Center Vent(s) and document the LH Temp. (Driver's Side) and RH Temp (passenger side).
4. Take photos of HVAC pressure gauges (High and Low) attach them to BOL and Label them "ENGINE RUNNING – PRESSURES"

**a. DYNAMIC (IDLE) LOW PRESSURE READING \_\_\_\_\_ BAR**

**b. DYNAMIC (IDLE) HIGH PRESSURE READING \_\_\_\_\_ BAR**

5. Measure the air temperature from the front-facing vents using a digital thermometer. Set the HVAC TEMP to LOW with the fan speed on HIGH. Air distribution to front-facing vents. Attach a picture of the MIA of the front dash and A/C controls.
6. Attach another picture of the A/C machine with the engine fully warmed up and running with engine speed at 2500RPM Hold the engine there for 5 minutes then take a picture. Also, perform and attach another full vehicle report during this time so we can see and monitor parameter values. Attach the report to the BOL.

**a. DYNAMIC (2500 RPM) LOW PRESSURE READING \_\_\_\_\_ BAR**

**b. DYNAMIC (2500 RPM) HIGH PRESSURE READING \_\_\_\_\_ BAR**

### TRI-ZONE SYSTEM (Optional on some vehicles)

If the customer has concerns regarding this system, check the ICS-R for DTCs along with performing the same diagnosis.

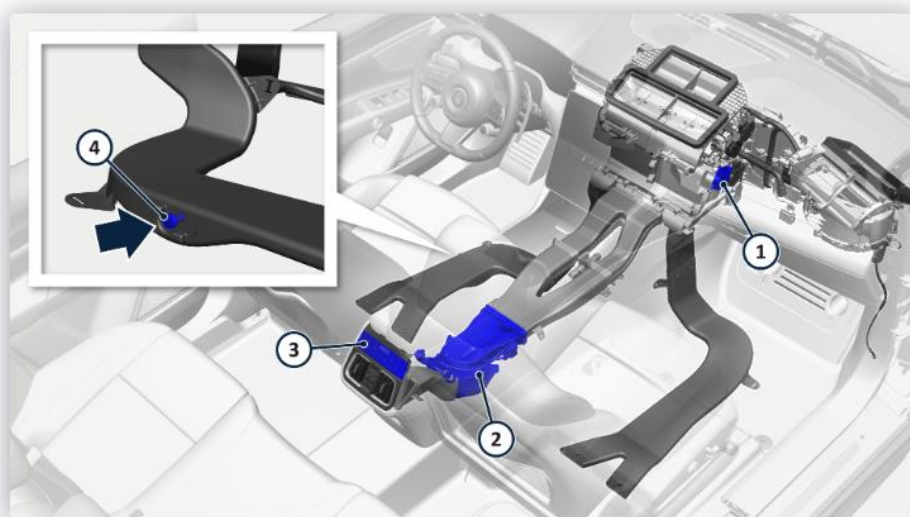

1. Rear temperature control actuator
2. Rear fan unit
3. Integrated Center Stack Rear (ICS\_R)
4. Rear left footwell temperature sensor