



Subject: NEW AUTOMATIC TRANSMISSION FLUID (ATF-A7)	Service Alert No.: SA-040/25
	Last Issued : 08/26/2025

BULLETIN NOTES

This Service Alert supersedes the previously issued SA(s) listed below. The changes are noted in Red.

Previous SAs:	Date(s) Issued:
SA-055/24	08/13/24
SA-055/23	09/28/23
SA-063/22	10/04/22

APPLICABLE MODEL(S)/VINS

- 2023-2026 CX-30 (2.5L)
- 2024-2025 CX-5 (2.5L)
- 2024-2026 CX-90 (MHEV and PHEV)
- 2025-2026 CX-70 (MHEV and PHEV)
- 2023-2026 Mazda3 (2.5L)

DESCRIPTION

A New Automatic Transmission Fluid (ATF-A7) is being used for some 2023-2026 models. ATF-A7 is an extremely low viscosity formulation with low friction to achieve best-in-class fuel economy and driving performance.

- For easy identification, ATF-A7 is colored Red and ATF-FZ is colored Blue.
- There is NO interchangeability between ATF-A7 and ATF-FZ.
- For CX-30, Mazda3, and CX-5, some 2.5L and all 2.5T engines still use ATF-FZ. Verify the type of ATF according to what is in MGSS (TRANSMISSION/TRANSAXLE TECHNICAL DATA) or what is marked on the dipstick (see below).

CONSUMER NOTICE: The information and instructions in this bulletin are intended for use by skilled technicians. Mazda technicians utilize the proper tools/ equipment and take training to correctly and safely maintain Mazda vehicles. These instructions should not be performed by "do-it-yourselfers." Customers should not assume this bulletin applies to their vehicle or that their vehicle will develop the described concern. To determine if the information applies, customers should contact their nearest authorized Mazda dealership. Mazda North American Operations reserves the right to alter the specifications and contents of this bulletin without obligation or advance notice. All rights reserved. No part of this bulletin may be reproduced in any form or by any means, electronic or mechanical---including photocopying and recording and the use of any kind of information storage and retrieval system ---without permission in writing.

CAUTION: When you need to change or refill the Automatic Transmission Fluid (ATF) for this ATX, always make sure to use “ATF-A7”. If any ATF other than “ATF-A7” is used in the ATX, Mazda cannot guarantee the performance or reliability of the above ATX. Any malfunction caused by usage of ATF other than “ATF-A7” WILL NOT be covered by warranty. Also, DO NOT use ATF-A7 for any other ATX, otherwise it could cause serious issues with the ATX.

For the ATX that requires ATF-A7, “A7” is marked on the dipstick as shown.

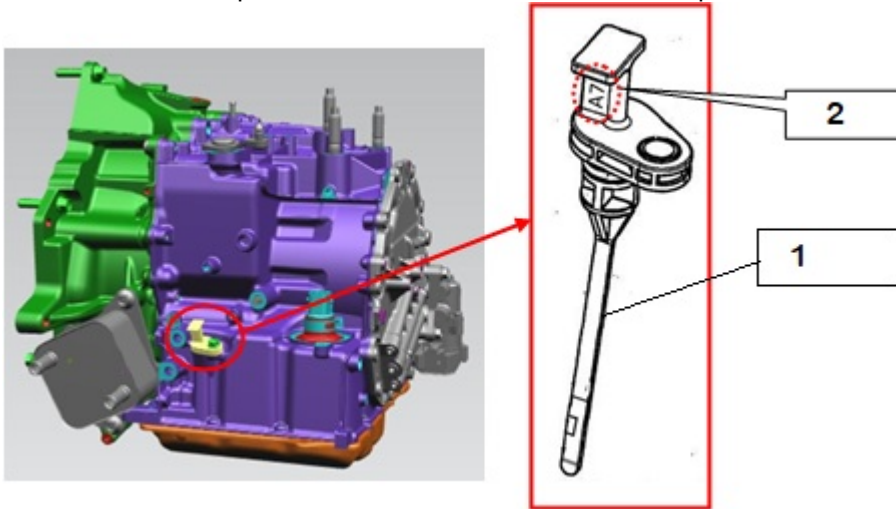

1	Dipstick
2	"A7"

NOTE: The dipstick is marked "FZ" for ATX that uses "FZ" ATF and any ATF other than "ATF-FZ" cannot be used.



PARTS INFORMATION

Product Name	Mazda Original Oil ATF A7
Part Number	0000-A7-115-QT
Packaging	12 bottles per box
Size of Bottles	1 Quart

CONSUMER NOTICE: The information and instructions in this bulletin are intended for use by skilled technicians. Mazda technicians utilize the proper tools/ equipment and take training to correctly and safely maintain Mazda vehicles. These instructions should not be performed by "do-it-yourselfers." Customers should not assume this bulletin applies to their vehicle or that their vehicle will develop the described concern. To determine if the information applies, customers should contact their nearest authorized Mazda dealership. Mazda North American Operations reserves the right to alter the specifications and contents of this bulletin without obligation or advance notice. All rights reserved. No part of this bulletin may be reproduced in any form or by any means, electronic or mechanical---including photocopying and recording and the use of any kind of information storage and retrieval system ---without permission in writing.



CONSUMER NOTICE: The information and instructions in this bulletin are intended for use by skilled technicians. Mazda technicians utilize the proper tools/ equipment and take training to correctly and safely maintain Mazda vehicles. These instructions should not be performed by "do-it-yourselfers." Customers should not assume this bulletin applies to their vehicle or that their vehicle will develop the described concern. To determine if the information applies, customers should contact their nearest authorized Mazda dealership. Mazda North American Operations reserves the right to alter the specifications and contents of this bulletin without obligation or advance notice. All rights reserved. No part of this bulletin may be reproduced in any form or by any means, electronic or mechanical--including photocopying and recording and the use of any kind of information storage and retrieval system ---without permission in writing.