

# RCA-18-24-001-3: Tighten Hub to Knuckle Fasteners

Rivian is initiating a customer satisfaction campaign for some model year 2023-2024 R1T and R1S vehicles. On these vehicles, the wheel hub to knuckle joint may have been assembled with an updated fastener using a torque value intended for the previously-used fastener. A fastener torqued to the previously-used lower value may cause an audible noise while driving at low speeds but will not impact vehicle performance. Rivian will retorque the affected fasteners and, if necessary, replace them. Rivian is launching this campaign for customer satisfaction and to ensure the quality of Rivian vehicles.



**Note:** This document supersedes RCA-18-24-001-2. Revision 3 updates the approximate build dates.

<b>Document Type</b>	Customer Satisfaction Campaign Bulletin
<b>Date</b>	August 1, 2025
<b>Affected Region(s)</b>	USA, Canada
<b>Affected Model(s)</b>	R1T, R1S
<b>Model Year(s)</b>	2023-2024
<b>Approximate Build Dates</b>	March 2023-August 2024
 Refer to <b>Open Containments</b> in ServiceOS to determine if this document applies to a specific vehicle.	
<b>Vehicle System</b>	18 - Suspension
<b>Minimum Service Location</b>	Mobile

## Potentially Required Parts

Part Number	Quantity	Engineering Name	Service Name/Notes
SC00006346-B	4	BOLT - M10X1.5X50 HX FL WSHR LOCK SPCL CL10.9 R105G	
SC00006315-A	16	BOLT - M12X1.25X50 HX FL CL10.9 R107G	



**Attention:** The parts listed in this table are only for unique steps that are called out in this bulletin. Some sections of this bulletin might refer to Service Manual procedures which require additional parts. Always review the bulletin and all potentially related Service Manual procedures before ordering parts and beginning work.

## Required Special Tools:

Tool Number	Tool Name
TSN01556-300-A	LOW PROFILE R1 HUB SOCKET, 18MM
TSN01561-100-A	3/8" DR. WOBBLE EXTENSION, 3" LONG
TSN01562-100-A	3/8" DR. WOBBLE EXTENSION, 10" LONG



**Attention:** The special tools listed in this table are only for unique steps that are called out in this bulletin. Some sections of this bulletin might refer to Service Manual procedures which require additional special tools. Always review the bulletin and all potentially related Service Manual procedures before beginning work.

# Inspection

1.
  - If using a vehicle lift: Raise and Support Vehicle (refer to service manual procedure 981020017).
  - If not using a vehicle lift:
    - a. Set the ride height to highest.
    - b. On the center display: Turn on **Tire Change** mode.
2. Inspect the marking on the heads of the highlighted fasteners.
  - LH and RH front:

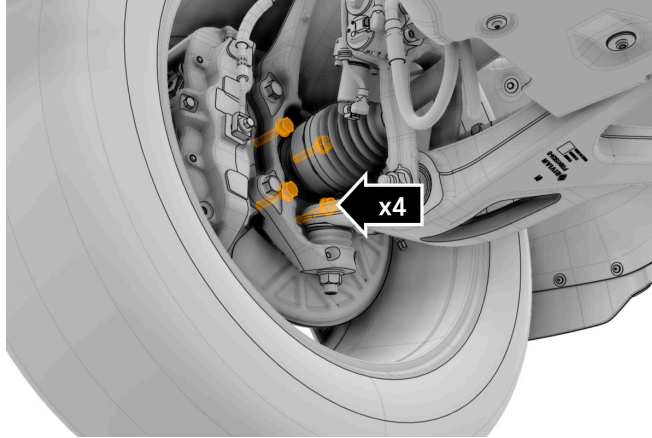

- LH and RH rear:

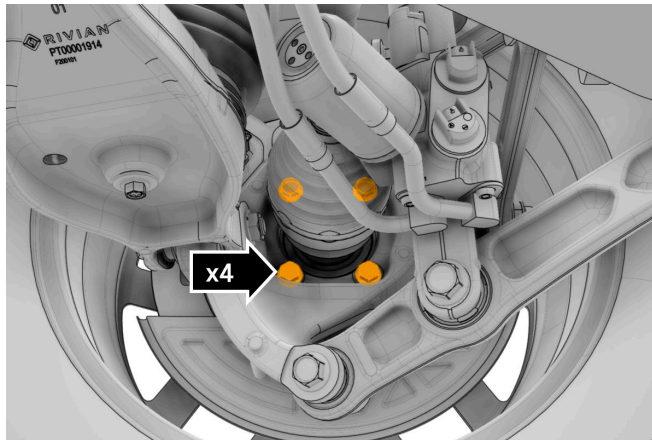

Each fastener will have **A&A** or **SPF** marked on it. If any hub has a combination of both **A&A** and **SPF** fasteners, or if the markings on any fastener is not readable: Replace all fasteners on that hub. Refer to the appropriate section of this bulletin:

- [Replace Front Hub - Knuckle Fasteners](#)
  - [Replace Rear Hub - Knuckle Fasteners](#)
3. Perform the [Retorque Hub - Knuckle Fasteners](#) section of this bulletin.



**Note:** Do not retorque any fasteners that were replaced as result of the previous step.

## Retorque Hub - Knuckle Fasteners

1. LH and RH front: Using the 18 mm hub socket and wobble extension: Tighten:

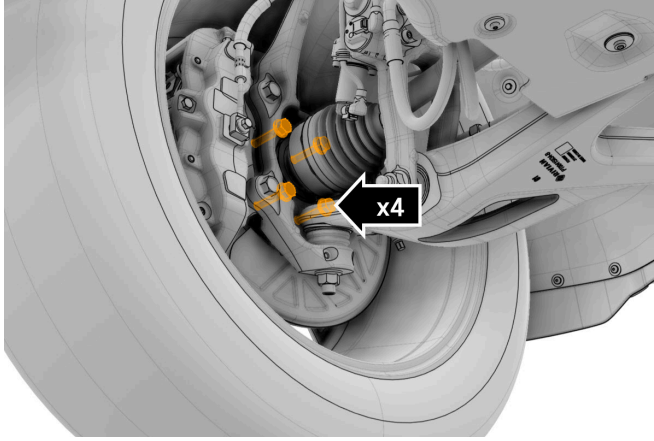

**i** **Tip:** If necessary: Add a standard extension between the torque wrench and wobble extension.

2. LH and RH rear: Using the 18 mm hub socket and wobble extension: Tighten:

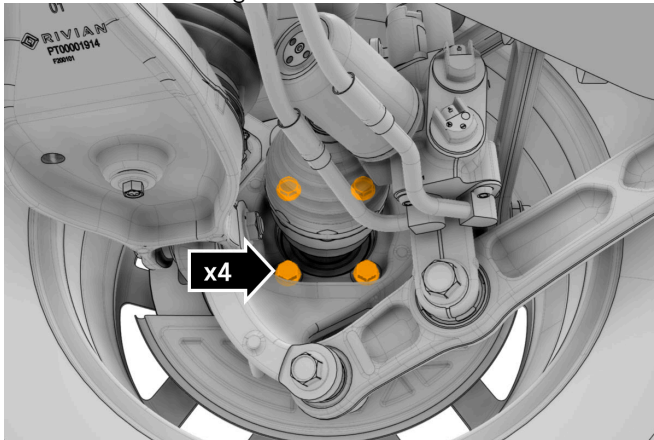

**i** **Tip:** If necessary: Add a standard extension between the torque wrench and wobble extension.

#### Torque specifications in this section

Step Number	Torque (Nm)
Hubs with all <b>A&amp;A</b> fasteners	105
Hubs with all <b>SPF</b> fasteners	135

## Replace Front Hub - Knuckle Fasteners

Perform this section only when directed, based on the results of the [Inspection](#) section.

1.

- Vehicles with 21 inch wheels: Remove: Cover, Wheel (refer to service manual procedure 221025010).
- Other vehicles: Remove:



**Note:** Pry in the highlighted area(s).

2. Remove and discard:

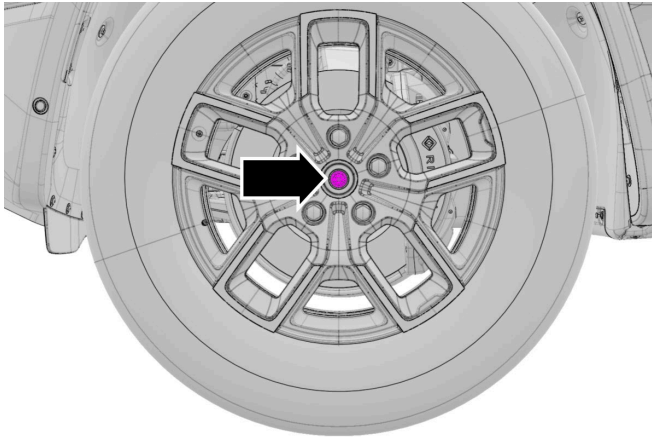

**CAUTION:** Non-reusable component(s).

- Using a 3/8 inch drive 17 mm deep socket: Press in on the front halfshaft as much as possible, then brace the socket against the inner lip of the wheel to keep the halfshaft in place.

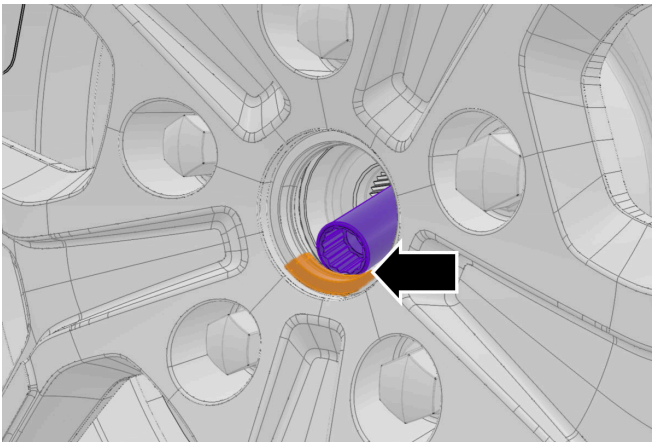
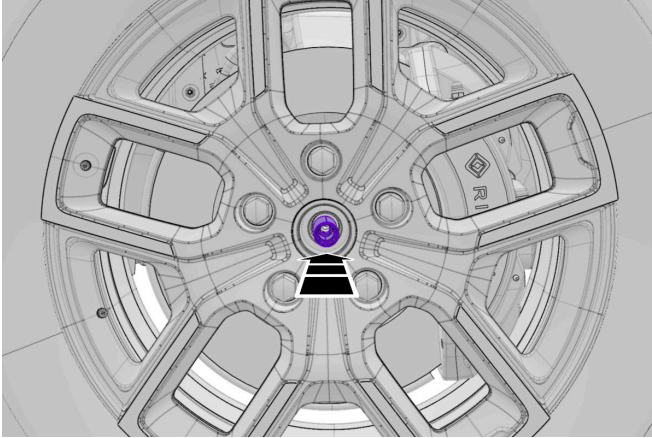

- Using the 18 mm hub socket and wobble extension: Replace:

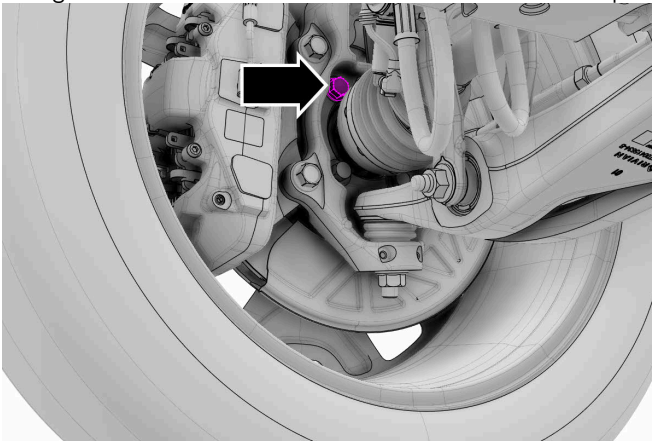

 **Tip:** If necessary: Add a standard extension between the torque wrench and wobble extension.

- Repeat step 4 on the other 3 fasteners that secure this hub. Replace one fastener at a time.

 **CAUTION:** Do not remove more than one fastener at a time.

6.

**Warning:** Put on work gloves to avoid a pinch condition in the next step.

7. Remove the socket that was installed in step 3.

8. Make sure that the halfshaft is properly seated within the knuckle.

9. Install, using new component(s):



**Note:** When installing the halfshaft bolt:

- a. Use a new bolt.
- b. Torque the bolt to 80 Nm.
- c. Loosen the bolt 1 turn.
- d. Torque the bolt to 128 Nm.

10. Reinstall the components that were removed in step 1.

**Torque specifications in this section**

Step Number	Torque (Nm)
4	135
9	128

## Replace Rear Hub - Knuckle Fasteners

Perform this section only when directed, based on the results of the [Inspection](#) section.

1.

- Vehicles with 21 inch wheels: Remove: Cover, Wheel (refer to service manual procedure 221025010).
- Other vehicles: Remove:

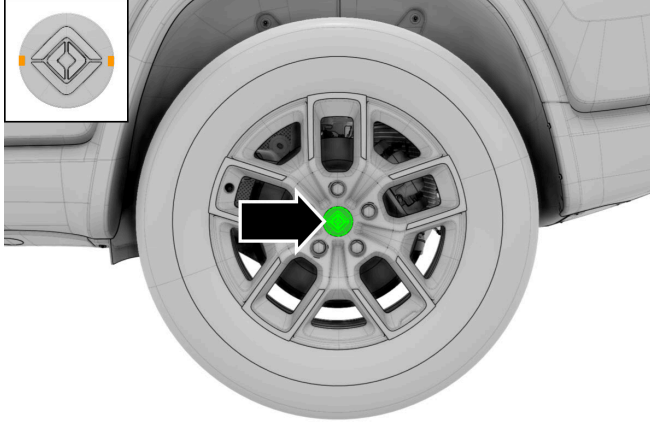

**Note:** Pry in the highlighted area(s).

2. Remove and discard:



**CAUTION:** Non-reusable component(s).

- Using a 3/8 inch drive 17 mm deep socket: Press in on the rear halfshaft as much as possible, then brace the socket against the inner lip of the wheel to keep the halfshaft in place.

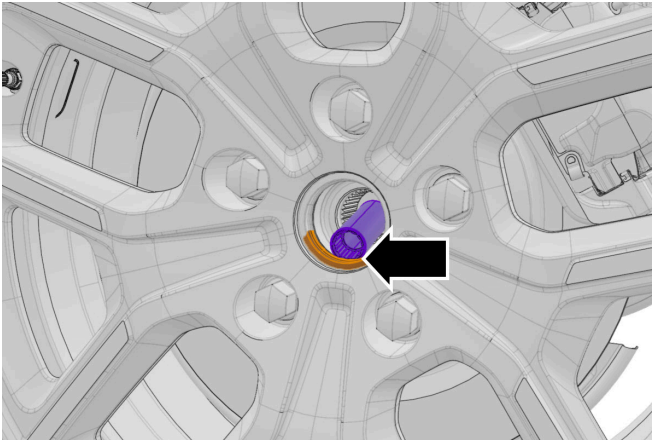

- Using the 18 mm hub socket and wobble extension: Replace:

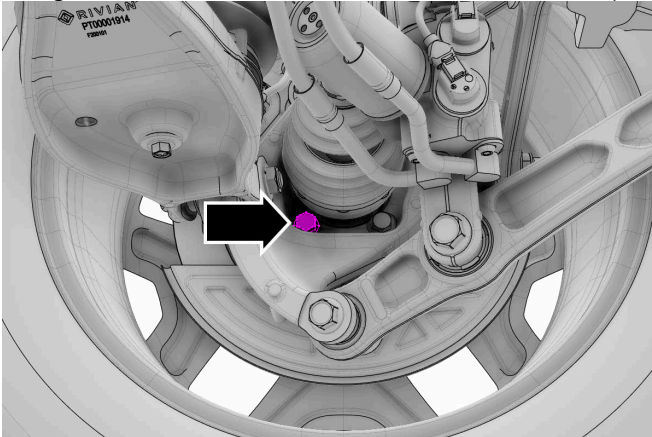

 **Tip:** If necessary: Add a standard extension between the torque wrench and wobble extension.

- Repeat step 4 on the other 3 fasteners that secure this hub. Replace one fastener at a time.

 **CAUTION:** Do not remove more than one fastener at a time.

6.

**Warning:** Put on work gloves to avoid a pinch condition in the next step.

7. Remove the socket that was installed in step 3.

8. Make sure that the halfshaft is properly seated within the knuckle.

9. Install, using new component(s):



**Note:** When installing the halfshaft bolt:

- a. Use a new bolt.
- b. Torque the bolt to 80 Nm.
- c. Loosen the bolt 1 turn.
- d. Torque the bolt to 128 Nm.

10. Reinstall the components that were removed in step 1.

**Torque specifications in this section**

Step Number	Torque (Nm)
4	135
9	128

## Labor Codes

Labor Code	Description
RCA182400100	RCA-18-24-001 not applicable
RCA182400101	Obsolete labor code
RCA182400102	Tighten hub to knuckle fasteners in 4 locations
RCA182400103	Tighten hub to knuckle fasteners in 3 locations, replace fasteners in 1 location
RCA182400104	Tighten hub to knuckle fasteners in 2 locations, replace fasteners in 2 locations
RCA182400105	Tighten hub to knuckle fasteners in 1 location, replace fasteners in 3 locations
RCA182400106	Replace hub to knuckle fasteners in 4 locations
Contact <a href="mailto:ServiceDocumentFeedback@rivian.com">ServiceDocumentFeedback@rivian.com</a> regarding labor codes and document content.	