



FIELD SERVICE CAMPAIGN – 24213

04 August 2025

SUBJECT:

Hill Hold Assist Installation

MODELS INVOLVED:

IC Bus™ Electric CE Series school bus

DEFECT DESCRIPTION:

Certain IC Bus™ Electric CE Series school buses may need the installation of the Hill Hold Assist components.

SUBJECT DESCRIPTION:

Installing Hill Hold Assist (HHA) feature onto the vehicle using the installation kit. This kit includes pneumatic lines, fittings, valves, electrical terminated harnesses, and a switch. The pneumatic lines and fittings will be used to connect to the HHA valve assembly from the air tank, rear valve, and foot valve. The HHA valve assembly will be controlled with a switch. The electrical harnesses will be installed to the HHA solenoid valve, through the chassis harness, and to the Antilock Brake System (ABS) module. Refer to the most current IC Bus™ Electric CE Series Operation and Maintenance Manual for more details.

ELIGIBILITY:

This procedure applies ONLY to vehicles marked in the International® Service PortalSM with FSC 24213. Also complete any other open campaigns listed on the Service Portal at this time.

TOOLS REQUIRED:

| Description | Tool Number | Quantity |
|---|-------------|----------|
| Audio Unit Removal Tool | ZTSE4715 | 1 |
| Battery Charger 55 amp | PSC550CC | 1 |
| EZ-Tech® or EST with Service Diagnostics Solutions (SDS) Software | N/A | 1 |

Table 1 Tool Information

PARTS REQUIRED:

NOTE: See parts catalog for BOM if individual parts are needed.

| Part Number | Description | Quantity |
|-------------|--|----------|
| 8000989C91 | KIT, PART, HILL HOLD ASSIST INSTALLATION | 1 |
| 3578733C1 | LIGHT, INDICATOR, LED ON (GREEN) | 1 |

| Part Number | Description | Quantity |
|-------------|--|---|
| 3533928C1 | LIGHT, INDICATOR, LED BACKLIGHT (AMBER) | 1 |
| 8000988C91 | ANTILOCK BRAKE SYSTEM (ABS) CONTROL MODULE, UNPROGRAMMED | 1 (If Needed) See iKNow Article link in Step 6 |

Table 2 Parts Information

WORK INSTRUCTIONS

WARNING! To prevent personal injury or death, wear and use approved high-voltage Personal Protective Equipment (PPE) when near a high-voltage electric vehicle. Inspect PPE before use. Do not use gloves or other PPE with expired dates, holes, cracks or damage. NEVER touch energized ORANGE high-voltage cables or high-voltage components without wearing approved high-voltage PPE.

WARNING! To prevent personal injury or death, or damage to property, NEVER service a high-voltage vehicle without completing High-Voltage Safety training. Before working on vehicle, read and obey all High-Voltage Safety and Lock-Out Tag-Out procedures and information.

WARNING! To prevent personal injury or death, or damage to property, read all information in the Safety Information and High-Voltage Safety sections of the service manual.

WARNING! To prevent personal injury and / or death, or damage to property, park vehicle on hard flat surface, turn the engine off, set the parking brake, and install wheel chocks to prevent the vehicle from moving in both directions.

WARNING! To prevent personal injury and / or death, always wear safe eye protection when performing vehicle maintenance.

WARNING! To prevent personal injury and / or death, or damage to property, if the vehicle must be raised, do not work under the vehicle supported only by jacks. Jacks can slip or fall over.

WARNING! To prevent personal injury and / or death, or damage to property, keep flames or sparks away from vehicle and do not smoke while servicing the vehicle's batteries. Batteries expel explosive gases.

1. Park vehicle on a dry and level surface.
2. Put drive mode selector in Neutral and set parking brake.
3. Release air pressure from vehicle air tanks. Refer to appropriate service manual for detailed instructions.
4. Turn ignition to Key OFF position.
5. Install wheel chocks.

NOTE: The ABS module has a special order process and the VIN must be provided when ordering as a critical order.

6. Using the iKNow article [IK0400171](#), determine the status of the VIN:

[IK0400171](#)

- a. If VIN is on the list, order ABS module for Step 80. Continue to Step 7.
 - b. If VIN is not on the list, do not order ABS module. Continue to Step 7.
7. Turn 12V disconnect switch OFF. Refer to appropriate technician manual for instructions.
 8. Perform High-Voltage Isolation Level 2. Refer to appropriate technician manual for instructions.
 9. Unlatch and open hood.

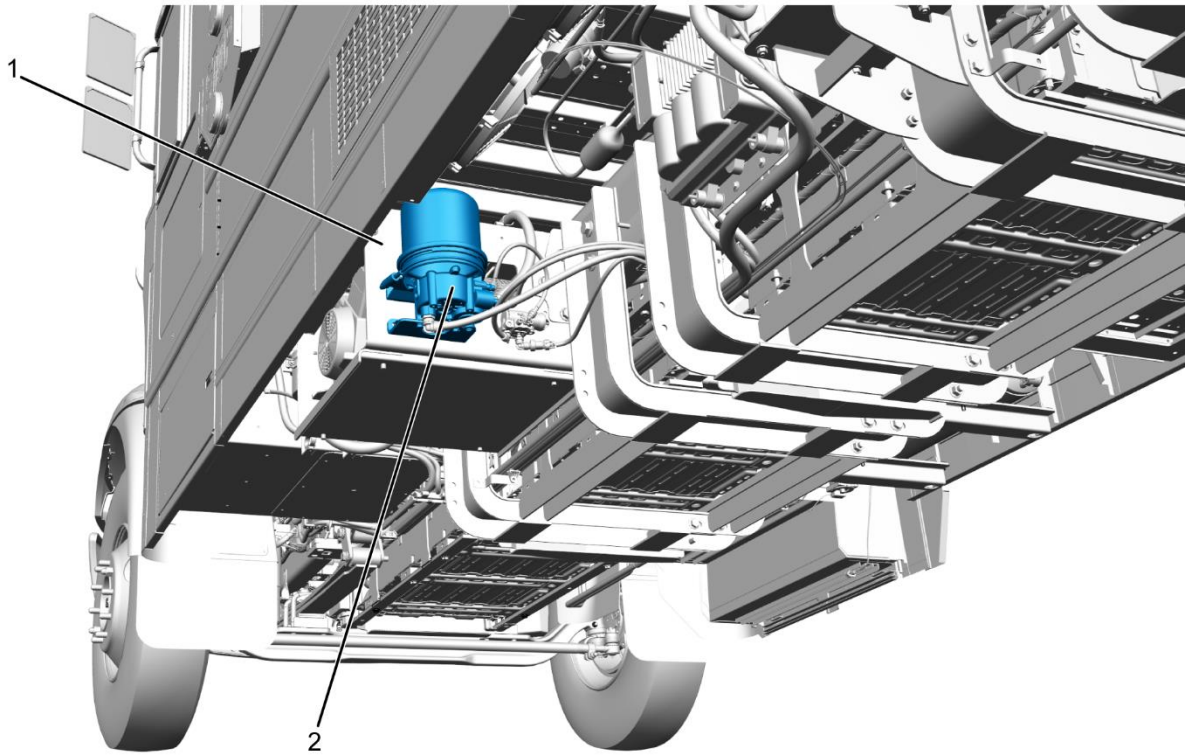

0000490638

Figure 1. Air Dryer Location

1. Outboard side of high-voltage air compressor box
2. Air dryer

10. Keep vehicle lifted to gain access to air dryer (Figure 1, Item 2).

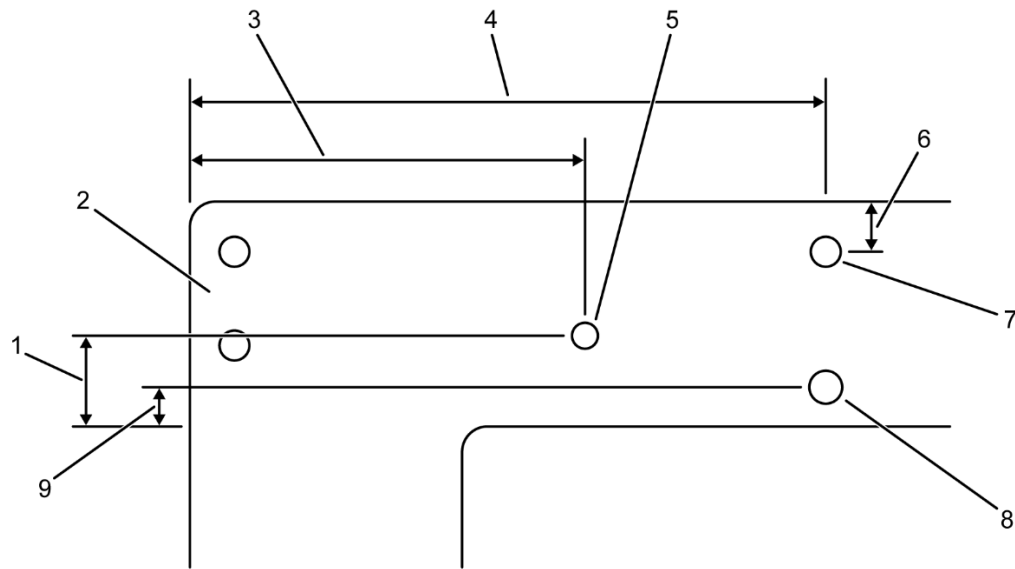

0000490639

Figure 2. Mounting Hole Locations (Outside of the Box)

1. Bottom edge to center of 1/4 in (6.35 mm) discharge line bracket hole: 2 3/8 in (60 mm)
 2. Outboard side of high-voltage air compressor box
 3. Right edge of box to center of discharge line bracket hole: 10 in (254 mm)
 4. Right edge of box to center of 0.7 in (16 mm) mounting hole: 15 in (26 mm)
 5. Discharge line bracket hole
 6. Top edge of box to center of 0.7 in (16 mm) alignment tab hole: 0.9 in (22 mm)
 7. Alignment tap hole
 8. Mounting bolt hole
 9. Bottom edge of box to center of 0.6 in (16 mm) mounting hole: 1 in (26 mm)
11. Using a light-colored paint marker, mark mounting hole locations (Figure 2, Items 5, 7 and 8) on outboard side of high-voltage air compressor box (Figure 2, Item 2) next to air dryer.
 12. Install 5/8 in (16 mm) diameter drill bit into drill.
 13. Drill one hole on the side of high-voltage air compressor box for HHA valve assembly support bracket using measurements (Figure 2, Items 4 and 9).
 14. Drill one alignment hole on the side of high-voltage air compressor box for alignment tab using measurements (Figure 2, Items 4 and 6).
 15. Install 1/4 in (6.35 mm) diameter drill bit into drill.

16. Drill one hole on the side of high-voltage air compressor box for discharge line support bracket using measurements (Figure 2, Items 3 and 5).
17. Debur drilled holes on the side of high-voltage air compressor box.

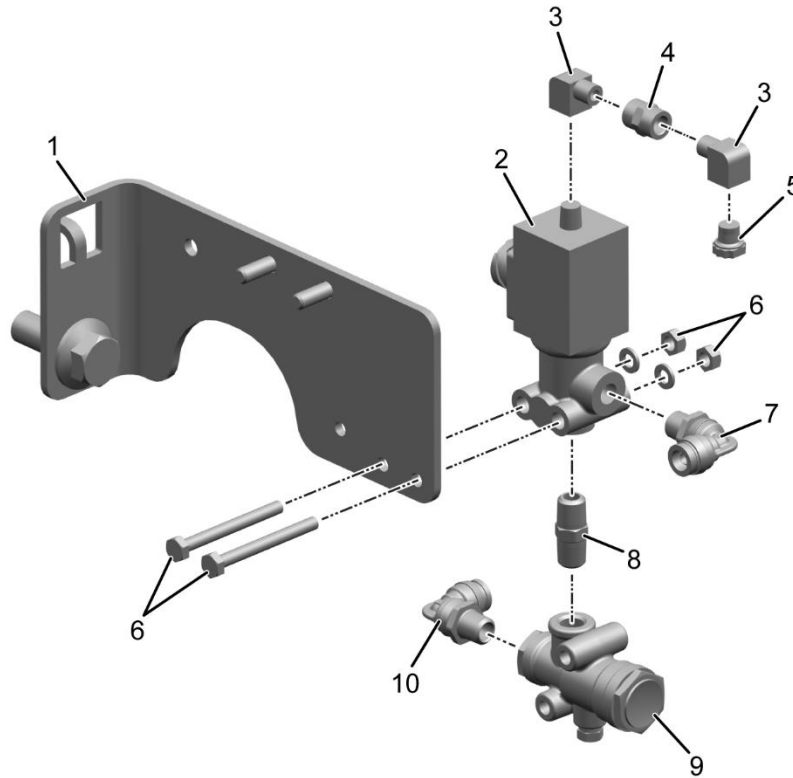

0000490640

Figure 3. Hill Hold Assist (HHA) Solenoid Valve Assembly

1. Bracket
2. HHA solenoid valve
3. Brass elbow fitting (2)
4. Pipe union
5. Release valve
6. Bolt, washer, and nut (2)
7. Composite elbow fitting
8. Pipe coupling
9. RV-3 pressure reducing valve
10. Composite elbow fitting

18. Install HHA solenoid valve (Figure 3, Item 2) onto HHA valve assembly bracket (Figure 3, Item 1).
19. Torque nut to 117 lb-in (13 N·m).

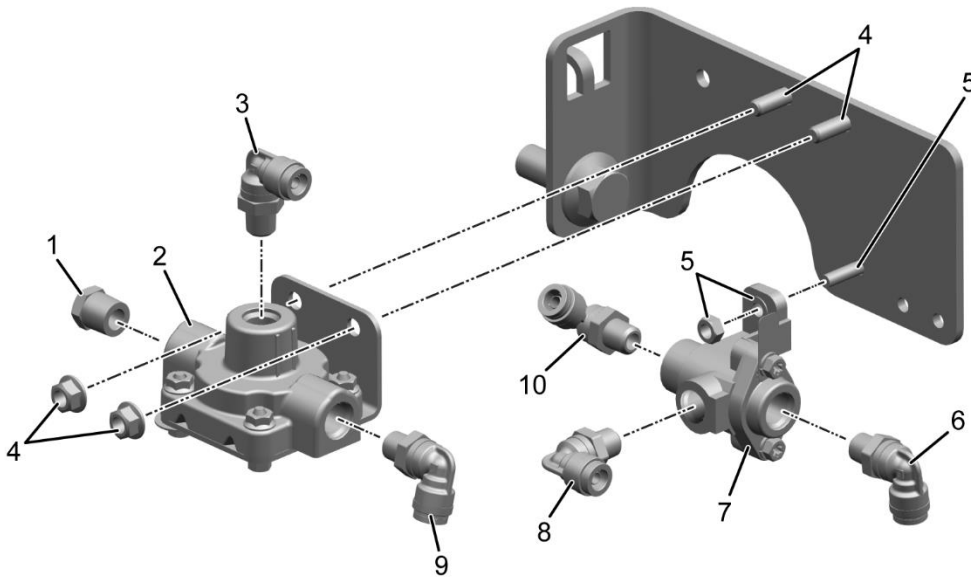

0000490641

Figure 4. Quick Release Valve (QRV) and Double Check Valve (DCV) Assembly

1. Brass plug fitting
2. QRV
3. Composite elbow fitting
4. Bracket stud (2)
5. Bolt, nut, and washer (1)
6. Composite elbow fitting
7. DCV
8. Composite elbow fitting
9. Composite elbow fitting
10. Composite elbow fitting

20. Install QRV (Figure 4, Item 2) onto HHA valve assembly bracket studs (Figure 4, Item 4).
21. Torque nut to 117 lb-in (13 N·m).
22. Install DCV (Figure 4, Item 7) onto HHA valve assembly bracket.
23. Torque nut to 117 lb-in (13 N·m).

NOTE: All the composite fittings can swivel into the appropriate position after torqued to specification

24. Install pipe coupling (Figure 3, Item 8) onto bottom of HHA solenoid valve (Figure 3, Item 2).
25. Install RV-3 pressure reducing valve (Figure 3, Item 9) onto pipe coupling (Figure 3, Item 8).
26. Position RV-3 pressure reducing valve to be perpendicular to HHA valve assembly bracket (Figure 3, Item 1).
27. Install control port brass elbow fitting (Figure 3, Item 3) to top of the HHA solenoid valve exhaust port.
28. Install pipe union (Figure 3, Item 4) to control port brass elbow fitting (Figure 3, Item 3).
29. Install control port brass elbow fitting (Figure 3, Item 3) to pipe union.
30. Position elbow brass fitting downward.
31. Install release valve (Figure 3, Item 5).
32. Install composite elbow fitting (Figure 3, Item 7) into control port of HHA solenoid valve (Figure 3, Item 2).
33. Install composite elbow fitting (Figure 3, Item 10) onto supply port of RV-3 pressure reducing valve (Figure 3, Item 9).
34. Install brass plug fitting (Figure 4, Item 1) to quick release valve delivery port (Figure 13, Item 4).
35. Install composite elbow fitting (Figure 4, Item 9) to remaining quick release valve delivery port.
36. Install composite elbow fitting (Figure 4, Item 3) to quick release valve supply port.
37. Install three elbow fittings (Figure 4, Items 6, 8, and 10) to double check valve.

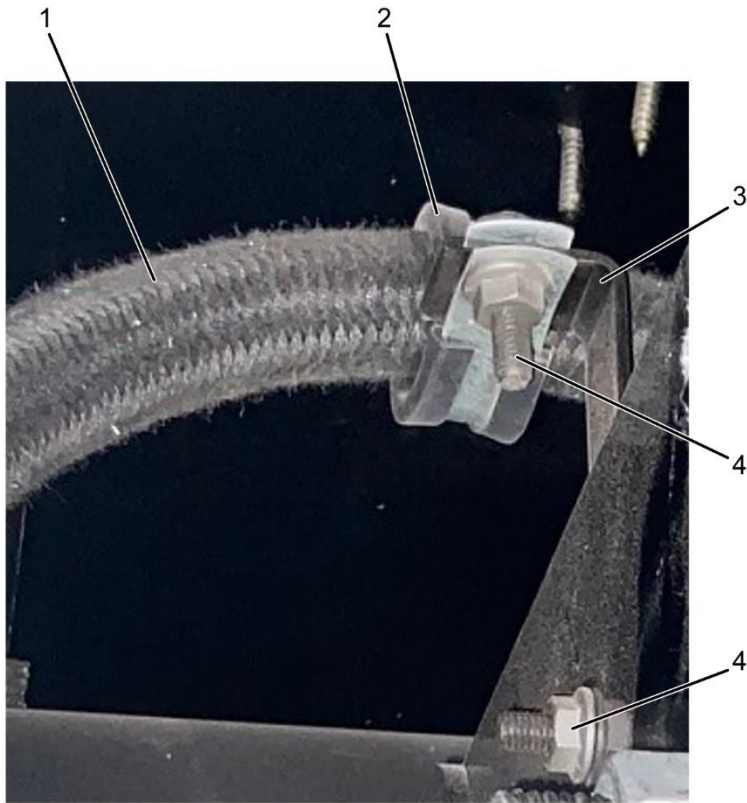

000490642

Figure 5. Air Compressor Discharge Hose

1. Air compressor discharge hose
 2. P-clamp
 3. Hose support bracket
 4. Bolt and nut assembly (2)
-
38. Remove bolt and nut assembly (Figure 5, Item 4) on P-clamp (Figure 5, Item 2) and high-voltage air compressor box.
 39. Remove hose support bracket (Figure 5, Item 3).
 40. Remove and discard P-clamp.

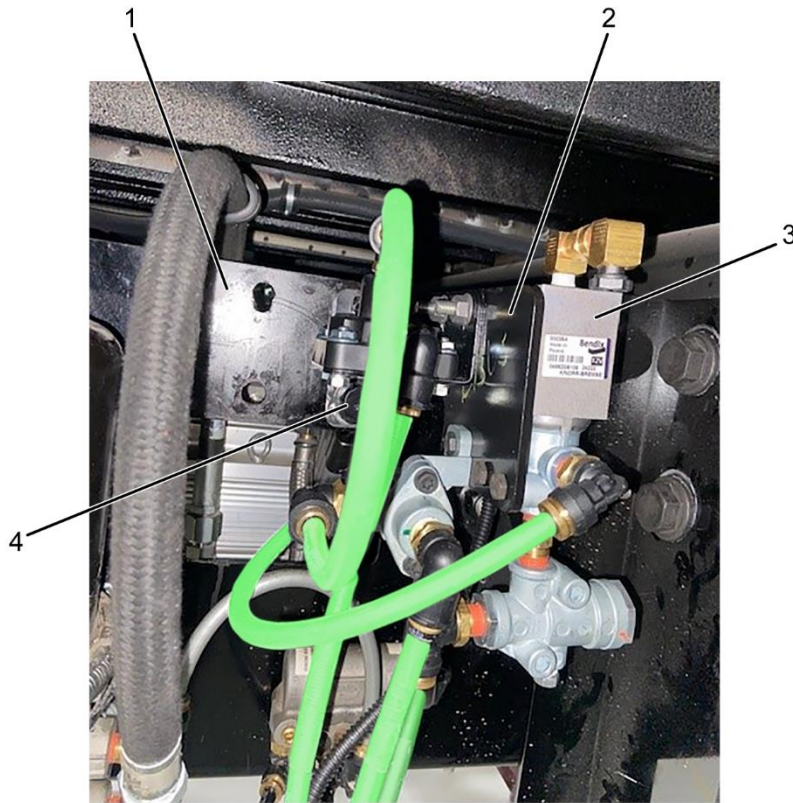

0000490643

Figure 6. HHA Valve Assembly Location

1. High-voltage air compressor box
2. HHA valve assembly bracket
3. HHA valve assembly
4. HHA valve assembly bracket mounting bolt and nut (not shown)

41. Install HHA valve assembly (Figure 6, Item 3) to side of high-voltage air compressor box (Figure 6, Item 1).
42. Torque HHA valve assembly mounting nut (Figure 6, Item 4) to 195–240 lb-ft (265–325 N·m).

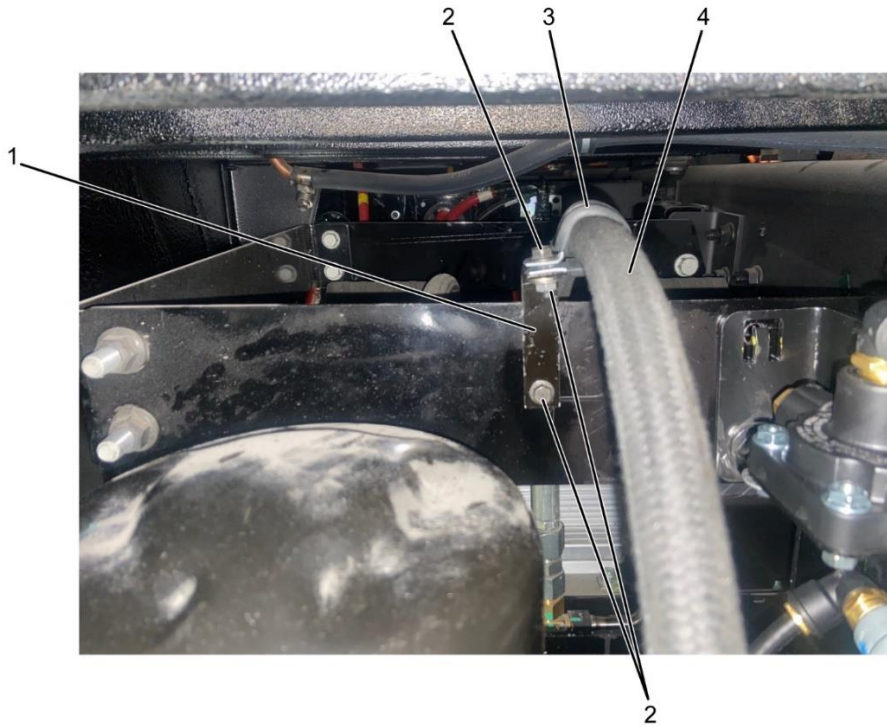

0000490644

Figure 7. Air Compressor Discharge Hose

1. Hose support bracket
 2. Bolt and nut assembly (2)
 3. P-clamp
 4. Air compressor discharge hose
-
43. Using bolt and nut assembly (Figure 7, Item 2), install hose support bracket (Figure 7, Item 1) to high-voltage air compressor box.
 44. Torque bolt and nut assembly to 90 lb-in (10 N·m).
 45. Position air compressor discharge hose (Figure 7, Item 4) onto P-clamp (Figure 7, Item 3) inboard of frame.
 46. Install new P-clamp (Figure 7, Item 3).
 47. Torque bolt and nut assembly to 90 lb-in (10 N·m).

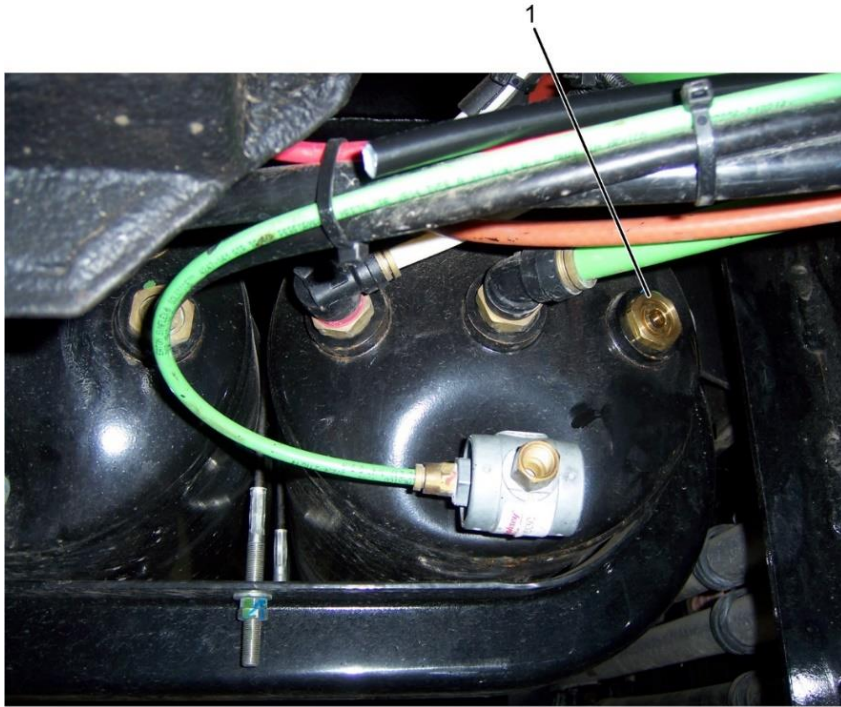

0000490645

Figure 8. Air Tank Routing

1. Air tank fitting
48. Locate extra plug on primary air tank.
49. Remove the plug and install air tank fitting (Figure 8, Item 1) to air tank.

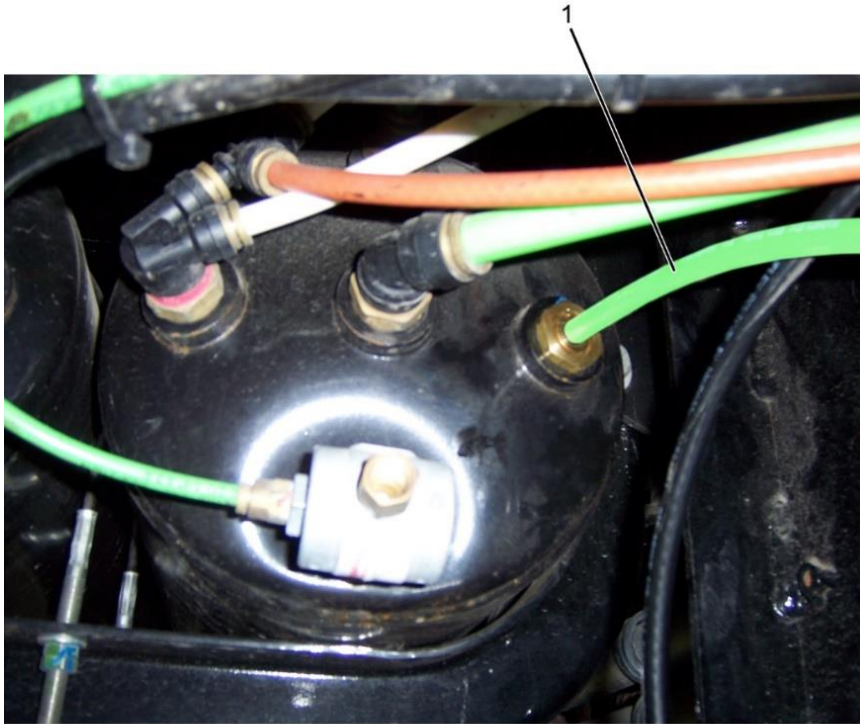

0000490646

Figure 9. Air Tank Routing

1. New green air line
50. Install new GREEN air line (Figure 9, Item 1) to new brass fitting on primary air tank.
51. Route new GREEN air line from the primary air tank fitting along driver-side frame rail to the HHA valve assembly.

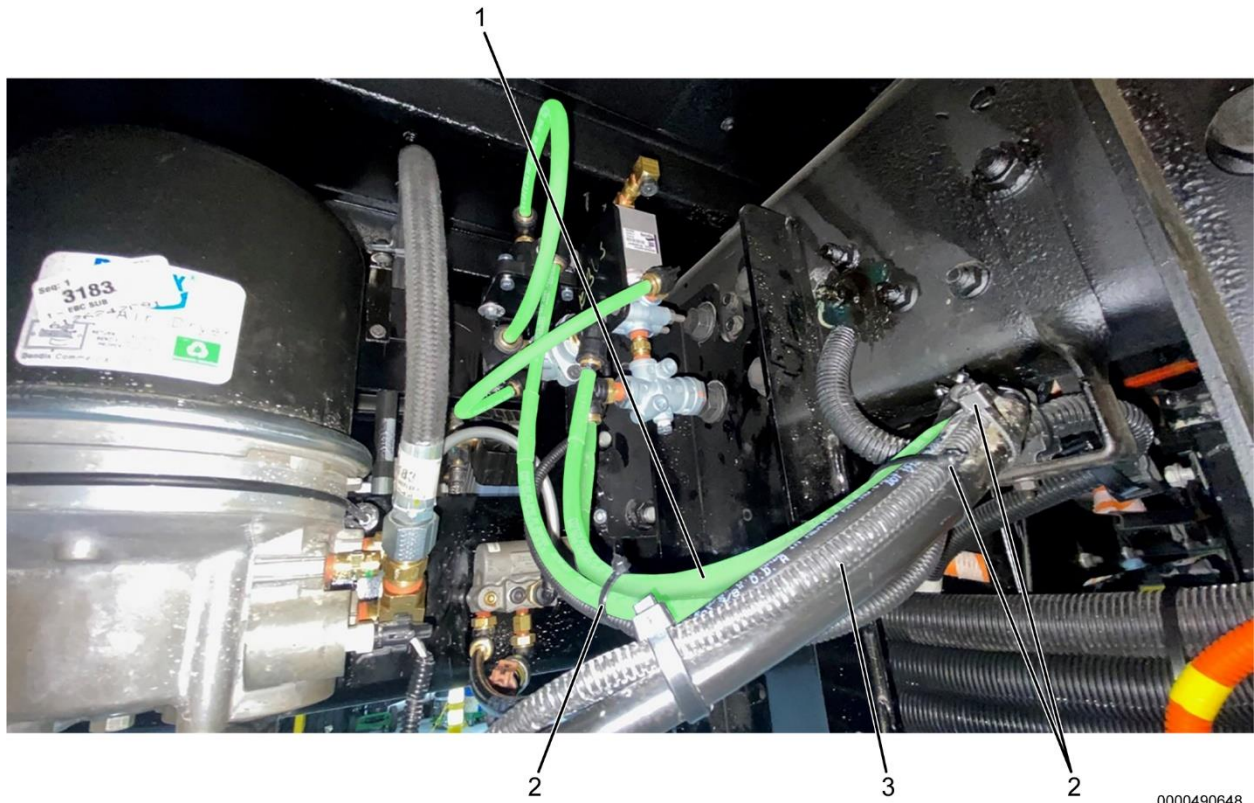

0000490648

Figure 10. Air Line Routing at HHA Valve Assembly

1. New airline route and bend
 2. Cable tie location (3)
 3. Existing electrical and air line routing
52. Cut new air line to appropriate length and route to reach the air line fitting. Refer to Figure 10 for appropriate routing and attachment points.

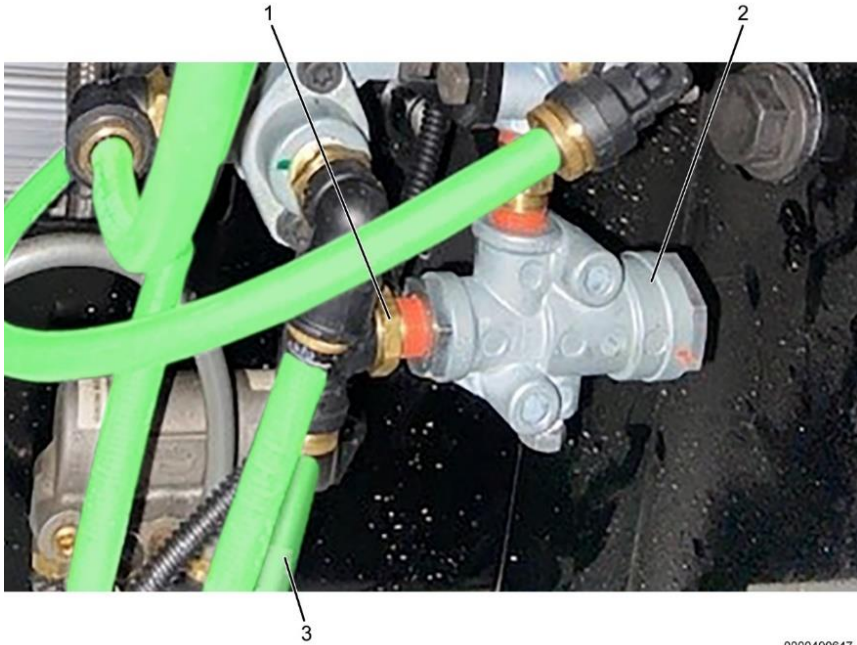

0000490647

Figure 11. RV-3 Pressure Reducing Valve

1. Composite elbow fitting
2. RV-3 pressure reducing valve
3. New air line from air tank

53. Install air line (Figure 11, Item 3) into composite elbow fitting (Figure 11, Item 1) on RV-3 pressure reducing valve (Figure 11, Item 2).

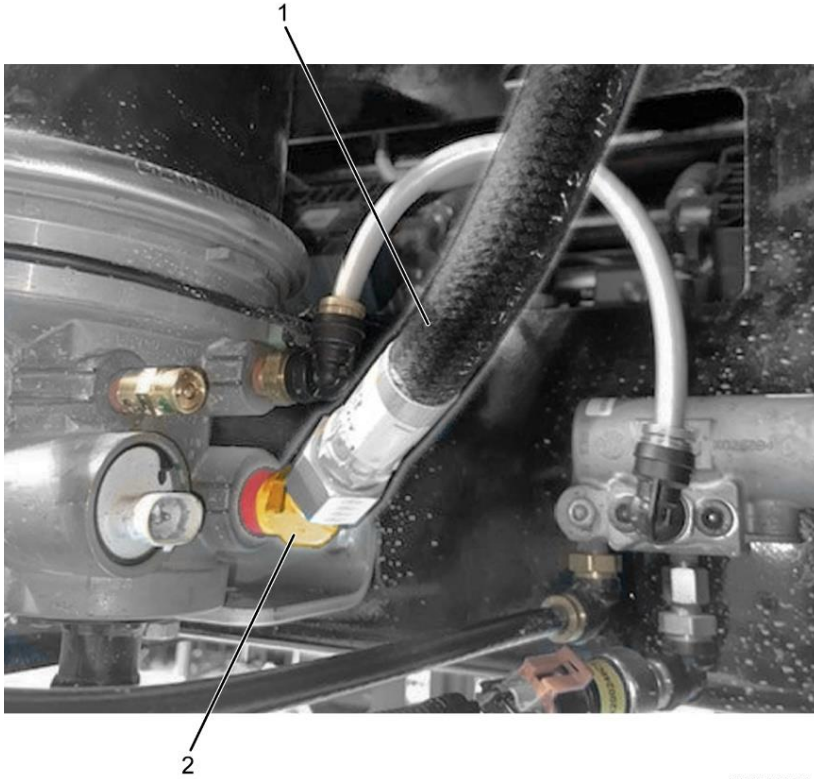

0000490739

Figure 12. Compressor Air Hose

1. Air hose
2. Brass elbow fitting

54. Remove compressor air hose (Figure 12, Item 1) from air dryer.
55. Remove brass elbow fitting (Figure 12, Item 2) from air dryer.

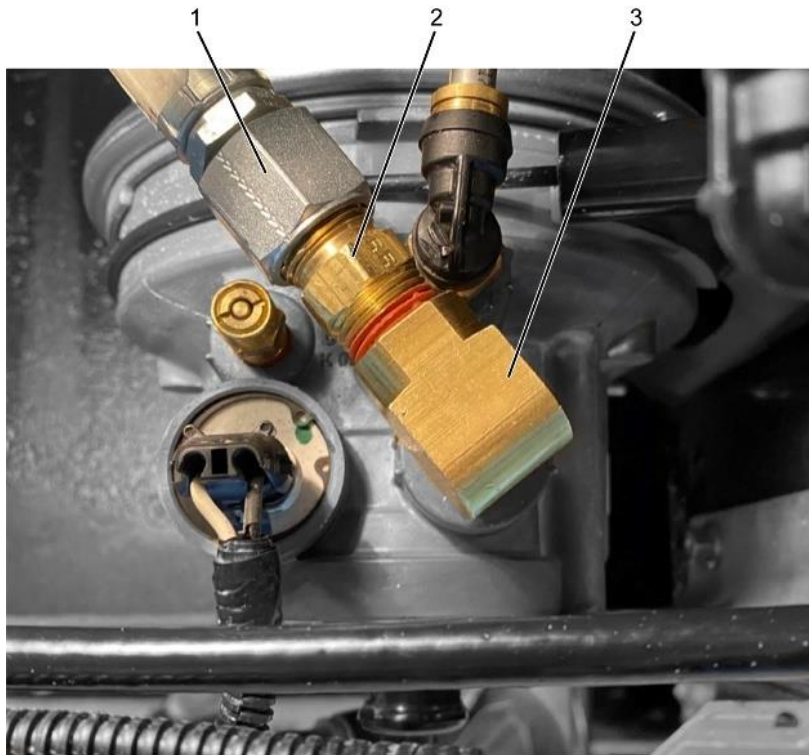

0000490740

Figure 13. Compressor Air Hose

1. Compressor air hose
2. Pipe coupler
3. Brass elbow fitting

56. Install 90° brass elbow fitting (Figure 13, Item 3).

57. Install pipe coupler (Figure 13, Item 2).

58. Install compressor air hose (Figure 13, Item 1).

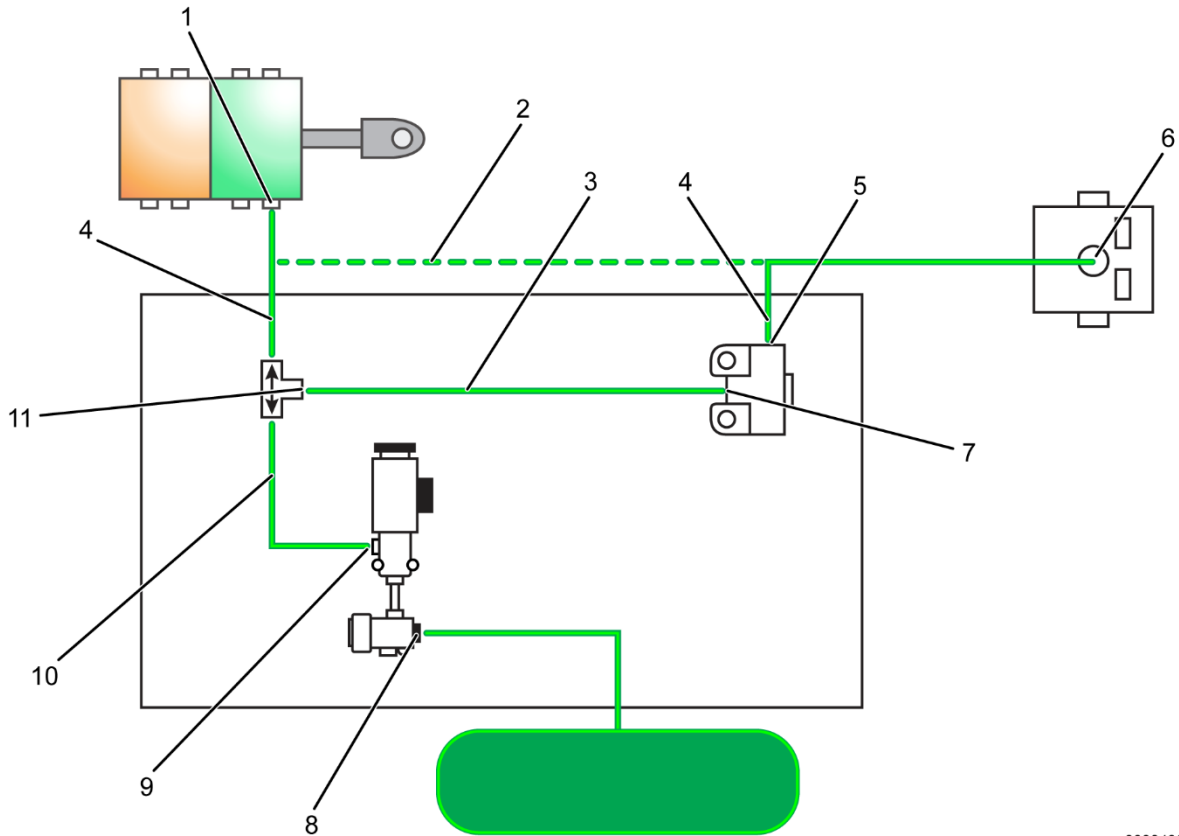

0000490741

Figure 14. Air Line Routing Overview

1. Foot valve delivery port
2. Original air line on vehicle
3. 14 in (356 mm) new green air line
4. 16 in (406 mm) new green air line
5. Quick release valve delivery port
6. Rear traction relay valve control port
7. Quick release valve supply port
8. RV-3 pressure reducing valve
9. HHA solenoid valve control port
10. 12 in (305 mm) new green air line
11. Double check valve delivery port

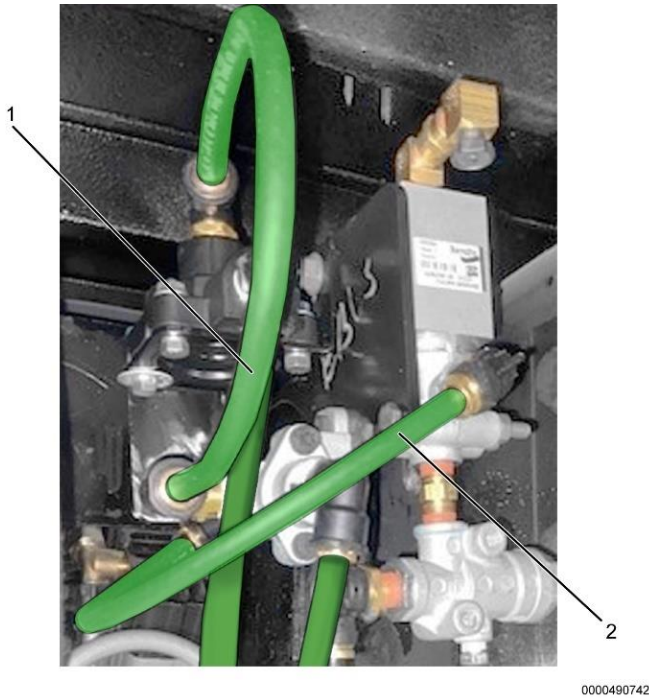

0000490742

Figure 15. Air Line Connection

1. 14 in (356 mm) green air line
2. 12 in (306 mm) green air line

59. Install a 14 in (356 mm) GREEN air line (Figure 15, Item 1) to quick release valve supply port (Figure 14, Item 7) and double check valve delivery port (Figure 14, Item 11).
60. Install a 12 in (305 mm) GREEN air line (Figure 15, Item 2) from double check valve supply port to HHA solenoid valve control port (Figure 14, Item 9).

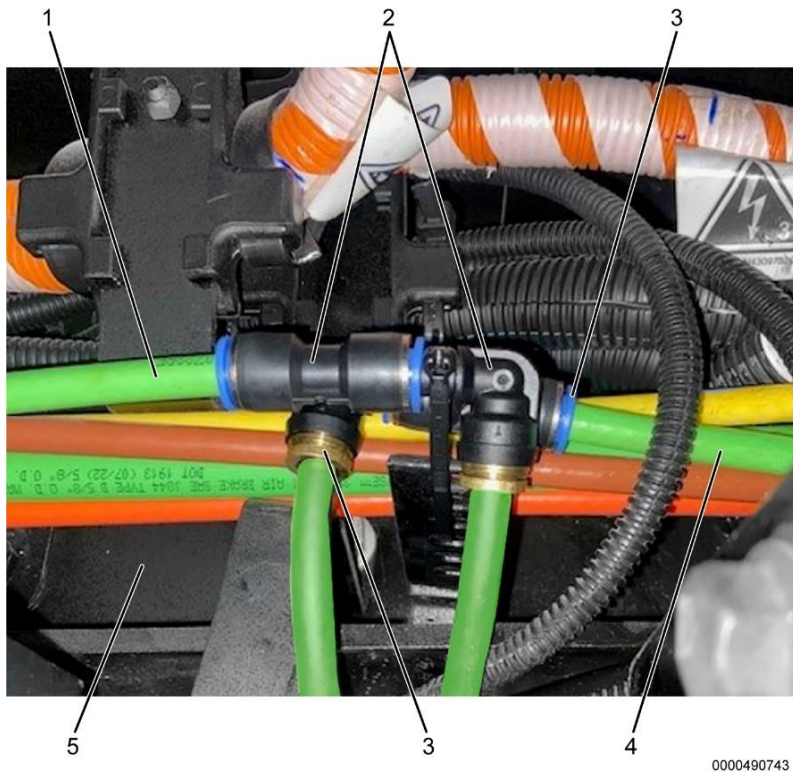

0000490743

Figure 16. Air Line Fitting Location

1. Green air line from rear traction relay valve
2. New air line fitting, straight and 90° elbow (2)
3. New air line fitting, straight and 90° elbow (2)
4. Green air line from foot valve
5. Driver-side frame rail

61. Locate GREEN air line (Figure 16, Items 1 and 4) from rear traction relay valve to foot valve inside of driver-side frame rail next to HHA valve assembly.
62. Cut air line.
63. Attach new air line fittings (Figure 16, Item 3) to GREEN air line from foot pedal (Figure 16, Item 4).
64. Attach new air line to fitting (Figure 16, Item 2) to GREEN air line from rear traction relay valve (Figure 16, Item 1).

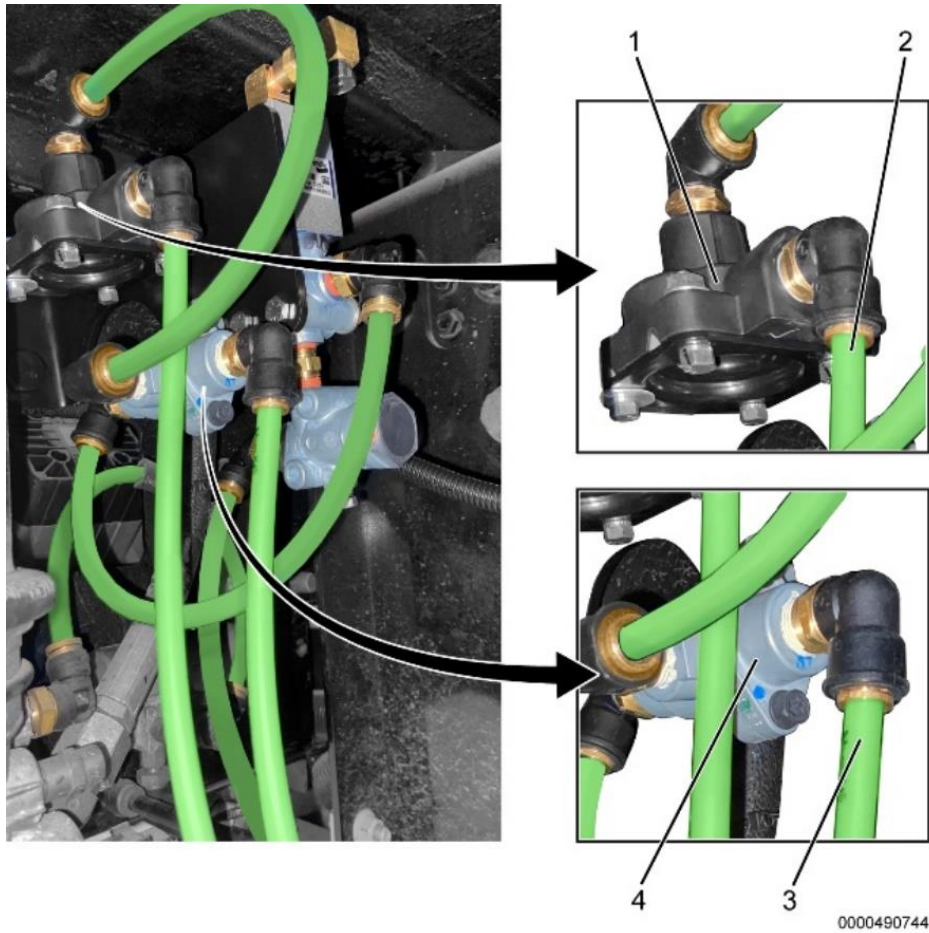
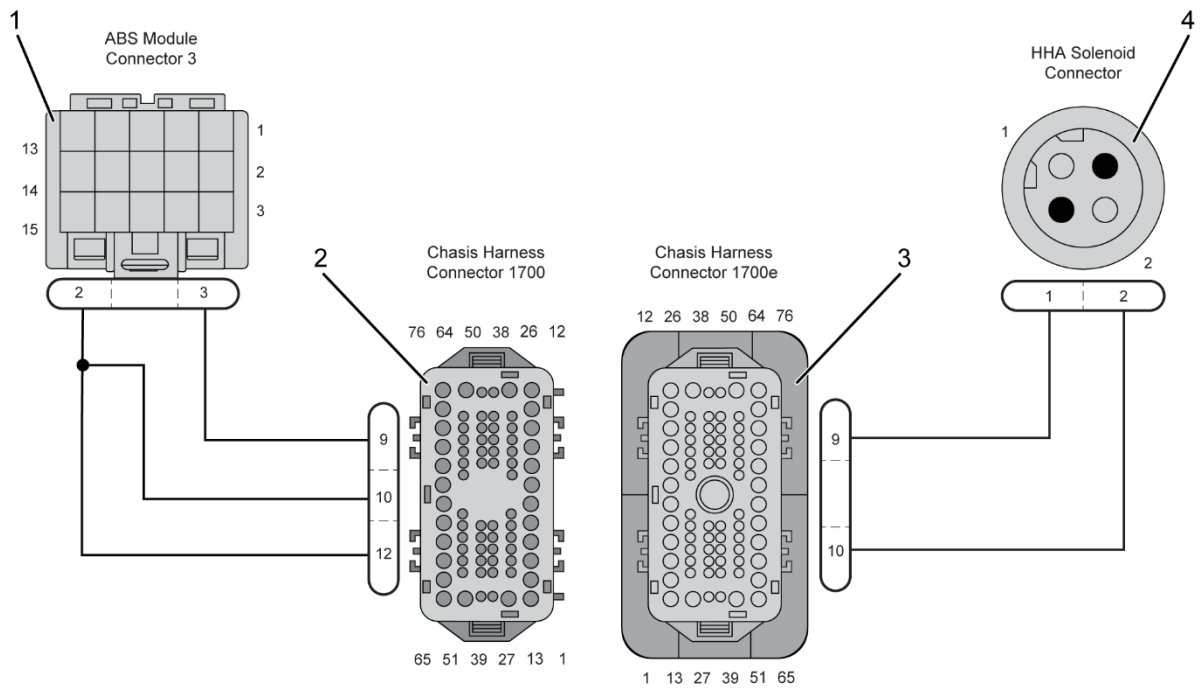

Figure 17. HHA Air Line Connection

1. Quick release valve
2. New green air line from rear traction relay valve
3. New green air line from foot valve
4. Double check valve

65. Install new GREEN air line from rear traction relay valve (Figure 17, Item 2) to quick release valve (Figure 17, Item 1).

66. Install new GREEN air line from foot valve (Figure 17, Item 3) to double check valve (Figure 17, Item 4).



0000490745

Figure 18. Connector Mating View

1. ABS X3 connector
2. Chassis harness connector 1700
3. Black forward chassis harness connector 1700e
4. HHA solenoid connector



0000490746

Figure 19. Harness Layout

1. HHA solenoid to black forward chassis harness connector 1700e harness (under hood)
 2. HHA solenoid connector female end
 3. Terminal for harness connector 1700e (2)
67. Connect harness (Figure 19, Item 1) to HHA solenoid male connector end (Figure 18, Item 4).
68. Route and secure the harness with the air line and electric harness along driver-side frame rail to the 1700e connector (Figure 18, Item 3).

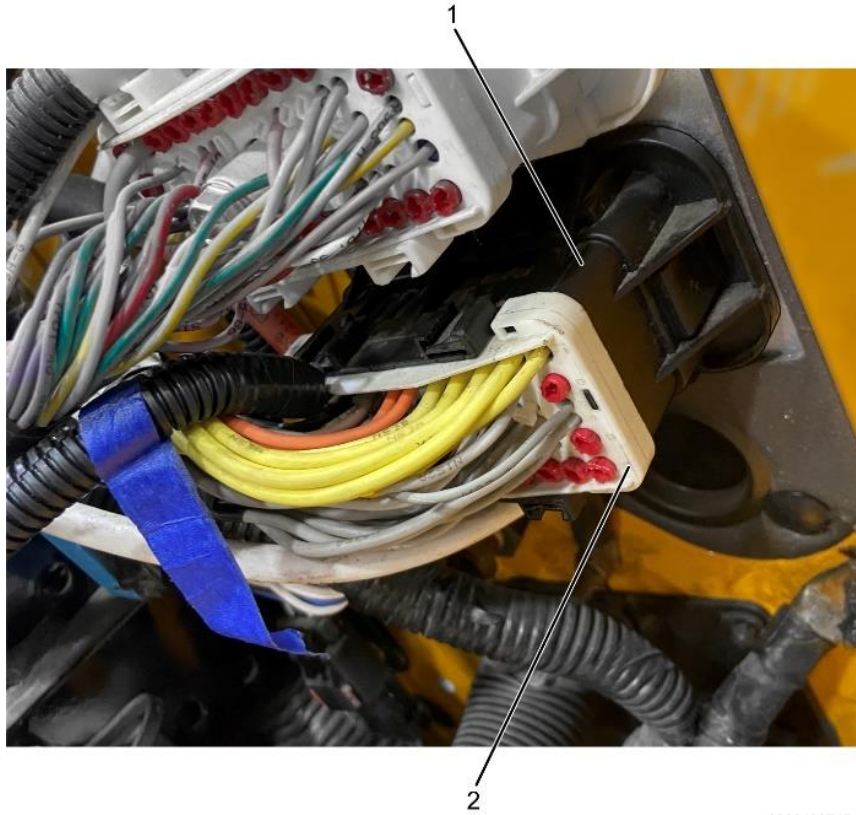

0000490747

Figure 20. BLACK Chassis Harness Connector 1700e Location

1. Black forward chassis harness connector 1700e
2. Terminal number

NOTE: Pin identification numbers are located on the sides of BLACK chassis connector.

69. Locate BLACK forward chassis harness connector 1700e (Figure 20, Item 1) under hood at driver-side bulkhead.
70. Carefully disconnect BLACK chassis harness connector 1700e (Figure 20, Item 1).

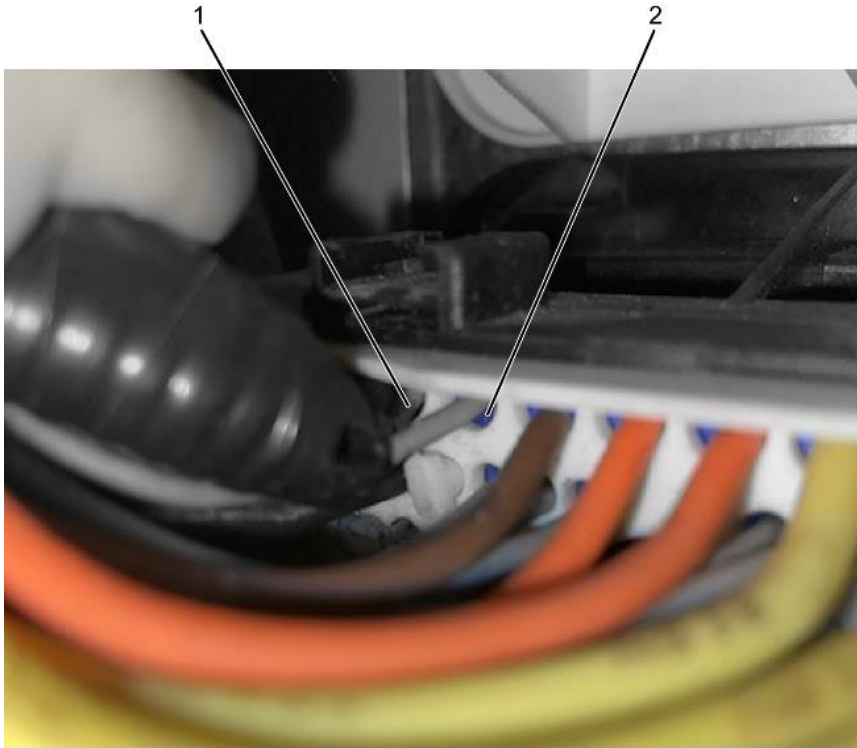

0000490748

Figure 21. Rear Chassis Connector 1700e Pin Identification

1. Cavity 10
 2. Cavity 9
-
71. Populate one end of harness (Figure 19, Item 3) into cavity 9 (Figure 21, Item 2) and cavity 10 (Figure 21, Item 1) of chassis harness connector 1700e (Figure 20, Item 1).
 72. Access ABS Control Module. Refer to appropriate technician manual for instructions.

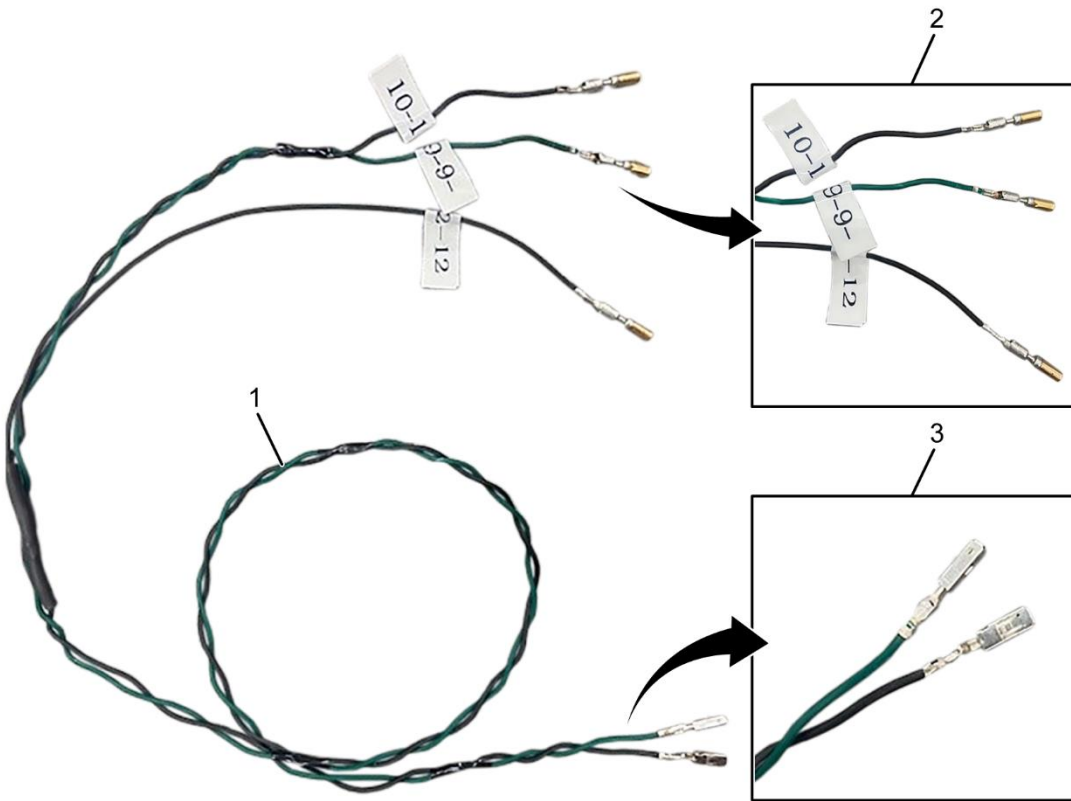

0000490681

Figure 22. Harness Layouts

1. Black forward chassis harness connector 1700 harness (interior) to ABS connector 3
2. Terminal for chassis harness connector 1700 (3)
3. Terminal for ABS X3 connector (2)



0000490682

Figure 23. ABS Module Connector 3 Pin Identification

1. Pin 3
2. Pin 2
3. ABS harness connector 3

NOTE: Pin identification numbers are located on the ABS harness connector 3 (Figure 23, Item 3) next to pin 3 (Figure 23, Item 1) for ease of pin identification.

NOTE: Any de-pinned wires need to be taped up and secured back. They will not need to be repinned.

73. Disconnect ABS harness connector 3 (Figure 23, Item 3).

74. De-pin terminal 3 in ABS harness connector 3 and tape up and secure wire.

75. Populate one end of harness (Figure 22, Item 3) into pin 2 (Figure 23, Item 2) and pin 3 (Figure 23, Item 1) of ABS harness connector 3 (Figure 23, Item 3).

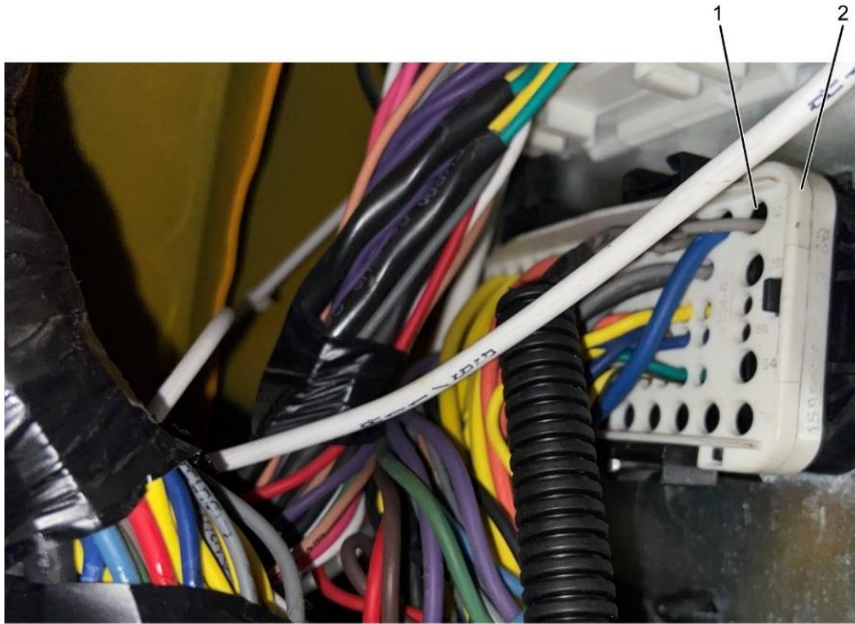

0000490683

Figure 24. BLACK Chassis Harness Connector 1700

1. Terminal 12
 2. Chassis harness connector 1700
76. Disconnect chassis harness connector 1700 (Figure 24, Item 2) located at inside driver-side dash panel.
 77. De-pin terminal 12 (Figure 24, Item 1) in chassis harness connector 1700.
 78. Populate other end of harness (Figure 22, Item 2) into cavities 9, 10, and 12 of chassis harness connector 1700.
 79. Route and secure harness by following existing wiring harness above ABS module and up to chassis harness connector 1700.
 80. Determine replacement status of ABS module:
 - a. If replacement of ABS module is necessary and VIN is on list, replace ABS module. Refer to the appropriate service manual for detailed instructions. After the replacement is complete, continue to Step 81.
 - b. If ABS module does not need to be replaced and VIN is not on list, continue to Step 81.
 81. Connect all connectors.



0000490684

Figure 25. HHA Switch

82. Using Audio Unit Removal Tool, release appropriate switch pack mounted on instrument panel from dash.
83. Slowly pull out switch pack and disconnect appropriate connectors.
84. Remove switch pack from vehicle.
85. Remove switch cover and install HHA switch (Figure 25) into IP switch packs.

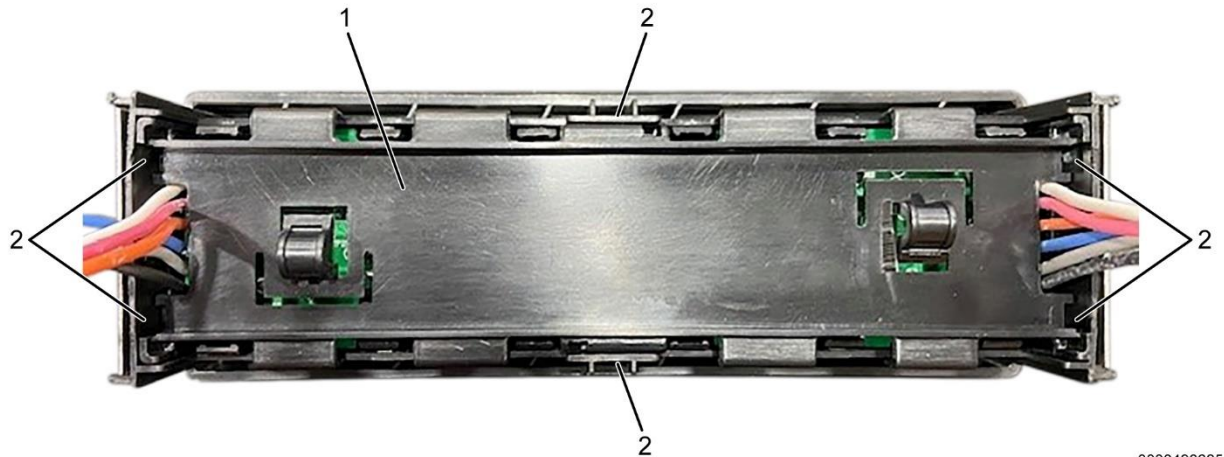

0000490685

Figure 26. Rear Cover

1. Rear cover
2. Snap (6)

86. Carefully remove six snaps (Figure 26, Item 2) in rear cover (Figure 26, Item 1).

NOTE: Each bulb is keyed to be installed into the printed circuit board in only one orientation. If the bulb will not insert into the circuit board, rotate the bulb one-half turn and try again. Turn the bulb into place with a short clockwise rotation.

87. Install light bulb with WHITE base onto the top of the circuit board for GREEN ON indicator.

88. Install light bulb with BLACK base onto the bottom of the circuit board for AMBER back lighting.

89. Install rear cover.

90. Install all appropriate Manual Service Disconnects (MSD) that were removed in Step 9. Refer to appropriate service manual for detailed instructions.

91. Turn ON 12V disconnect switch. Refer to appropriate service manual for detailed instructions.

92. Turn ON high-voltage disconnect switch. Refer to appropriate service manual for detailed instructions.

93. Connect battery charger / maintainer to vehicle battery.

94. Turn vehicle ignition to Key ON position.
95. Perform leak test on front, rear brake systems and HHA air line connections. Check for leaks.

NOTE: If the VCU has not been updated, please see [FSC 24107](#).

96. Launch Service Diagnostics Solutions (SDS) software.
97. Determine if VCU is updated to V10000.
 - a. If VCU is not updated to V10000, then complete FSC 24107.
 - b. If VCU is updated to V10000, then go to Step 98.
98. Close SDS application.
99. Cycle ignition key from ON position to OFF position, then back to ON position.
100. Launch Diamond Logic® Builder (DLB) software.

NOTE: The EV Cluster update may take up to 30 min to complete.

101. Select EDIT, then Update Software, then Update All Software to update all modules that are capable of being updated.
102. Select Program.

| Detected Modules | | | | | | Selected Module | | Detected | |
|--|---------|------------------|------------------|--------|---------------|-----------------|-----------|----------|--|
| Module | Address | Data Link | In Configuration | Kernel | Description | ESC | ESC | | |
| ESC | 33 | Drivetrain J1939 | | 632 | | | | | |
| EV Cluster | 23 | Drivetrain J1939 | ✓ | 50914 | Serial | 222850119 | 222850119 | | |
| Unknown module | 90 | Drivetrain J1939 | | | Hardware | 505 | 505 | | |
| Battery Pack Monitor | 243 | Drivetrain J1939 | | | Configuration | 17 | 17 | | |
| Battery Thermal Management System (BTMS) | 202 | Drivetrain J1939 | | | Kernel | 632 | 632 | | |
| Brakes - System Controller | 11 | Drivetrain J1939 | | | Data Version | 462 | 462 | | |
| Cabin Heater Electric Coolant Pump | 182 | Drivetrain J1939 | | | State | | | | |
| Cruise Control | 17 | Drivetrain J1939 | | | | | | | |
| DC to DC Converter #1 | 179 | Drivetrain J1939 | | | | | | | |
| DC to DC Converter #2 | 176 | Drivetrain J1939 | | | | | | | |
| Engine | 0 | Drivetrain J1939 | | | | | | | |
| Fan Control Module | 78 | Drivetrain J1939 | | | | | | | |
| HVAC Control Module | 25 | Drivetrain J1939 | | | | | | | |
| Onboard Charger Interface (OCI) | 128 | Drivetrain J1939 | | | | | | | |
| Power Electronics Electric Coolant Pump | 181 | Drivetrain J1939 | | | | | | | |

0000490686

Figure 27. DLB Module List

1. Data version

103. Verify BCM / ESC is data version (Figure 27, Item 1) 450 or greater.

104. Verify EV Cluster is data version (Figure 27, Item 1) 05.09.07 or greater.

| Feature | Description | Installed |
|---------|---|-------------------------------------|
| 0595LBS | BC PROG, HILL START AID Use with Electric Vehicles | <input checked="" type="checkbox"/> |
| 0595RAY | BC PROG, TURN SIGNALS/BRAKE Hazard Lights, with ... | <input type="checkbox"/> |
| 0595QAX | BC PROG, ELECTRICAL GRID CONT EV Bus Architecture | <input type="checkbox"/> |
| 0595QAR | BC PROG, NEUTRAL CONFIRMATION, GEN 4 Enhanced Ar... | <input type="checkbox"/> |
| 0595QAJ | BC PROG, CRANK INHIBIT, GEN 4 Enhanced Architecture | <input type="checkbox"/> |
| 0595QAH | BC PROG, KEY SWITCH GEN 4 Enhanced Architecture | <input type="checkbox"/> |
| 0595JBJ | BCM PROG, Noise Suppression Switch for eBus | <input type="checkbox"/> |
| 0595JAK | BC PROG, BODY CONTROLLER for Bus, GEN 4, 505 Har... | <input type="checkbox"/> |
| 0595BZR | BC PROG, TRACTION CONTROL IND (Bendix ATC Off Ro... | <input type="checkbox"/> |
| 0595BZF | BC PROG, INTERLOCK WHEELCHAIR for EV Bus | <input type="checkbox"/> |
| 0595BZH | BC PROG, IP CONFIGURATION for EV Bus, Cluster | <input type="checkbox"/> |
| 0595BYX | BC PROG, ENGINE PARAMETERS International A26 Eng... | <input type="checkbox"/> |
| 0595BFD | BC PROG, FRIDL With 1000/2000 6 Speed Transmiasi... | <input type="checkbox"/> |
| 0595BNA | BC PROG, BRAKE LT W/RETARDER ECE or ADR Complian... | <input type="checkbox"/> |
| 0595BDH | BC PROG, AIR COMPRESSOR MOTOR INHIBIT for High V... | <input type="checkbox"/> |
| 0595BDG | BC PROG, REGENERATIVE BRAKING SYSTEM for Electri... | <input type="checkbox"/> |
| 0595BDE | BC PROG, FARK / MARKER LIGHTS Dual Output, 20AMP... | <input type="checkbox"/> |
| 0595BAZ | Fog Lights for Bus with Rocker Switch only | <input type="checkbox"/> |
| 0595BAU | BC PROG, HEADLIGHT REMINDER for Bus | <input type="checkbox"/> |
| 0595AYC | BC PROG, WINDSHIELD WIPER Without Low Washer Flu... | <input type="checkbox"/> |
| 0595ARV | BC PROG, SHIFT SELECTOR INHIBIT for electric dri... | <input type="checkbox"/> |

0000490687

Figure 28. Feature 595LBG Check Box

1. Feature 595LBG
2. Check box

105. Determine if feature 595LBG (Figure 28, Item 1) is visible and has a check in check box (Figure 28, Item 2):

- If feature is not visible and check in check box is missing, go to Step 106.
- If feature is visible and check in check box is present, go to Step 107.

106. Select feature 595LBG and select Program.

107. Download and save Bendix Retrofit file:

[Bendix Retrofit File](#)

NOTE: If the ABS ECU update does not process properly, verify the wiring was installed properly. The update will not process if it does not see the ABS solenoid for HHA is installed.

NOTE: Bendix ACOM report parameters pertaining to HHA will still show disabled after completing programming.

108. Launch Bendix Retrofit software.

109. Enter following credentials:

- a. Username: BCI2024-328
- b. Password: International 2025!

110. Select LOGIN.

111. Determine correct Job ID by the last digit of vehicle VIN.

- a. VIN last digit is 0 or 1: Select Job ID 10001523.
- b. VIN last digit is 2 or 3: Select Job ID 10001524.
- c. VIN last digit is 4 or 5: Select Job ID 10001525.
- d. VIN last digit is 6 or 7: Select Job ID 10001526.
- e. VIN last digit is 8 or 9: Select Job ID 10001527.

112. Select appropriate communication link.

113. Select J1939 Baud Auto Channel 1 baud rate.

114. Select PRE-CHECK button.

115. Enter part number and serial number listed below:
- a. Part Number: K242888A000
 - b. Serial Number: 1M0519G000
116. Select OK.
117. Once precheck status is complete, select PERFORM UPDATE.
118. Check the check box if battery voltage is above 10 volts.
119. Select OK.
120. Disconnect battery charger / maintainer from vehicle battery.
121. Verify operation of HHA system.
122. Verify operation of light in HHA switch.
123. Remove wheel chocks.

LABOR INFORMATION

Operation number must appear on all claims.

| Operation Number | Description | Time |
|------------------|------------------------------------|----------|
| A40-24213-1 | Hill Hold retrofit installation | 2.65 hrs |
| A40-24213-2 | ABS ECU installation (if required) | 0.2 hrs |
| A40-24213-3 | High-Voltage isolation level 2 | 0.9 hrs |

Table 3 Labor Information

WARRANTY CLAIMS

Warranty claim expense is to be charged to Warranty. Claims are to be submitted in the normal manner, making reference to Field Service Campaign 24213.

Section 7 of the Warranty Policy and Procedures Manual contains further information related to the submission and processing of AFC / Recall claims.

As with all claim submissions, items acquired locally must be submitted in the “Other Charges” tab. The cost of any bulk items (such as a bag of cable tie straps, roll of wire, barrel of oil, or tube of silicone) should be prorated for the cost of the individual pieces / amount used during each repair.

To make sure that this important improvement is made in a timely manner, all claims for 24213 activity must be submitted by 04 August 2026 or within the normal warranty period for the component, if after 04 August 2026.

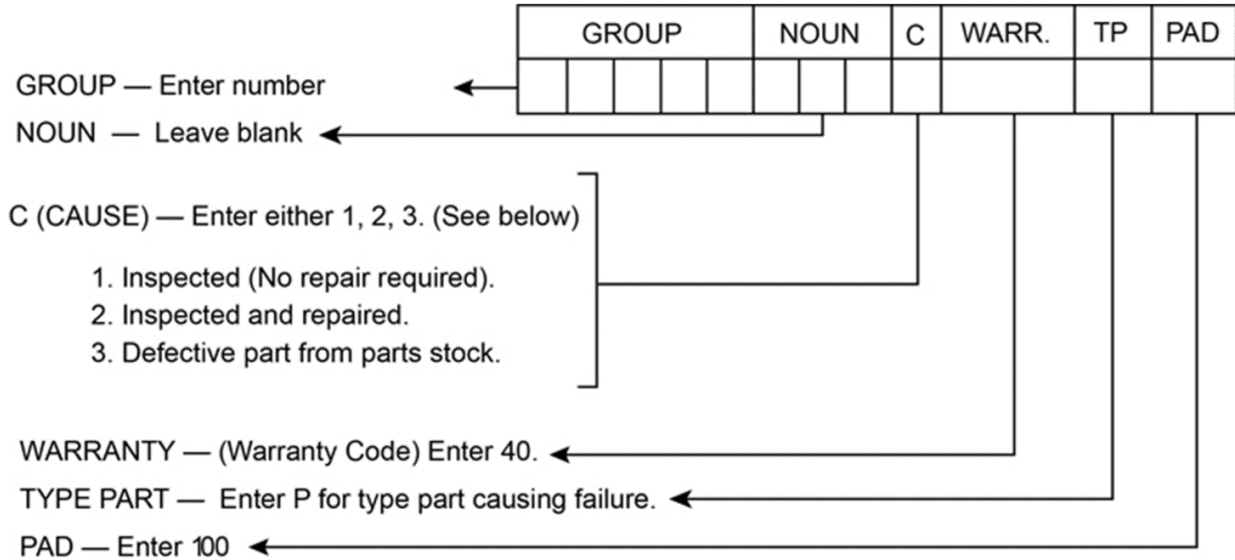

0000047910