

- ATTENTION:**
- GENERAL MANAGER
 - PARTS MANAGER
 - CLAIMS PERSONNEL
 - SERVICE MANAGER

IMPORTANT - All Service Personnel Should Read and Initial in the boxes provided, right.

© 2025 Subaru of America, Inc. All rights reserved.



QUALITY DRIVEN® SERVICE

SERVICE PROGRAM BULLETIN

APPLICABILITY: 2017 MY Forester (turbo) **NUMBER:** WRA-25R
 2017 MY WRX **DATE:** 06/27/25

SUBJECT: Rear Catalyst (Center Exhaust Pipe) **REVISED:** 08/11/25
 Non-Compliance

INTRODUCTION

In the interest of customer satisfaction, Subaru of America, Inc. (Subaru) is initiating a new voluntary emissions recall for certain 2017 model year WRX and Forester vehicles equipped with a 2.0L turbo engine.

REASON FOR THIS VOLUNTARY EMISSIONS RECALL

The performance of the rear catalyst (Center Exhaust Pipe) may cause the affected vehicles to exceed exhaust emission standards.

REMEDY

Subaru will replace the rear catalyst (Center Exhaust Pipe) with an improved one on all affected vehicles. Subaru will also reprogram the Electronic Control Unit (ECU) on affected vehicles equipped with a manual transmission. This repair will be performed at no cost to the customer.

AFFECTED VEHICLES

A total of 42,847 U.S. vehicles will be affected by this recall, as listed below. Not all vehicles in the production range listed may be affected by this recall. Coverage must be confirmed by using the Vehicle Coverage Inquiry function on subarunet.com prior to repair.

Model Year	Carline	Production Date Range
2017	Forester (turbo)	March 24, 2016 – April 28, 2017
2017	WRX	February 3, 2016 – April 5, 2017

<p>CAUTION: VEHICLE SERVICING PERFORMED BY UNTRAINED PERSONS COULD RESULT IN SERIOUS INJURY TO THOSE PERSONS OR TO OTHERS.</p> <p>Subaru Service Bulletins are intended for use by professional technicians ONLY. They are written to inform those technicians of conditions that may occur in some vehicles, or to provide information that could assist in the proper servicing of the vehicle. Properly trained technicians have the equipment, tools, safety instructions, and know-how to do the job correctly and safely. If a condition is described, DO NOT assume that this Service Bulletin applies to your vehicle, or that your vehicle will have that condition.</p>	<p style="text-align: center;">Subaru of America, Inc. is ISO 14001 Compliant</p> <p>ISO 14001 is the international standard for excellence in Environmental Management Systems. Please recycle or dispose of automotive products in a manner that is friendly to our environment and in accordance with all local, state and federal laws and regulations.</p>
--	--

Continued...

RETAILER RESPONSIBILITY

Any vehicles listed in any recall/campaign that are in retailer stock must be:

- Immediately identified
- Tagged or otherwise marked to prevent their delivery or use prior to repair
- Repaired in accordance with the repair procedures outlined in the Product Campaign Bulletin





Retailers are to promptly perform the applicable service procedures, to correct all affected vehicles in their inventory (used, demo & SSLP). Whenever a vehicle subject to this recall is taken into retailer inventory necessary steps should be taken to ensure the recall correction has been made before selling or releasing the vehicle.

OWNER NOTIFICATION



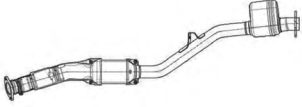

Subaru will notify affected vehicle owners by first class mail on June 30, 2025.

PART INFORMATION:

The following parts kits can be ordered through PRIME.

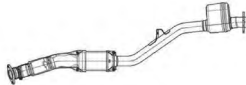
Manual Transmission				
Part Description		Part Number	Qty	Image
PIPE AY GSKT KIT MT		X4461AB240	1	
1	PIPE AY CTR-EXH,R		1	
2	GASKET		1	
3	GASKET(CR)		1	
4	FLANGE NUT		2	

Continued...

CVT				
Part Description		Part Number	Qty	Image
PIPE AY GSKT KIT CVT		X4461AB250	1	
1	PIPE AY CTR-EXH,R		1	
2	GASKET		1	
3	GASKET(CR)		1	
4	FLANGE NUT		2	

SERVICE PROCEDURE FLOW CHART:

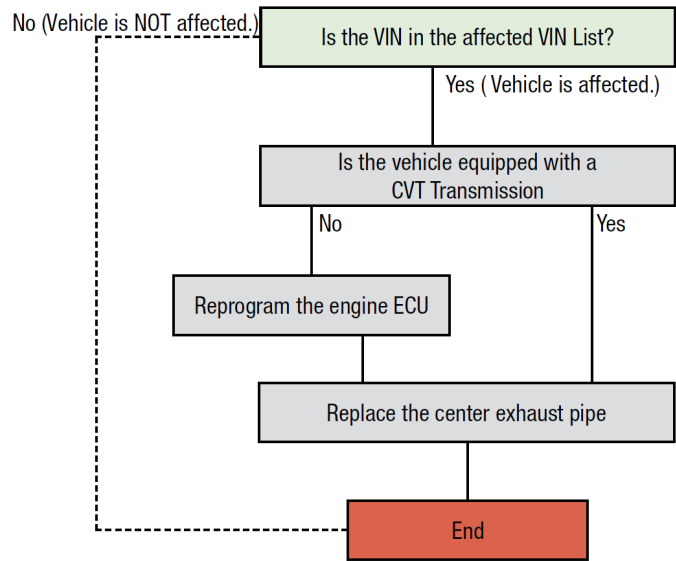







IMPORTANT NOTE: Manual Transmission equipped vehicles require successful reprogramming to complete this campaign. Vehicles with modified ECMs may not be able to be programmed preventing completion of the campaign. Always confirm the ECM can be successfully updated **BEFORE** proceeding with any parts replacement. Refer to the Service Procedures on Page 6 for more details.

PAK FILE INFORMATION:

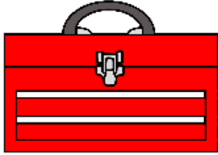
Model Year	Model	PAK File Name	New ECM Part Number	Description Keyword	New CID Number
2017	WRX 6MT	22765AK387.PAK	22765AK387	06B14459	LF79130P

Continued...

REQUIRED TOOLS & MATERIALS:

Description	Image	Details
General hand tools		
Torque wrench		Required for torquing hardware
Heat resistant gloves		Required for Technician safety
Air gun		Required for cooling heated area
WD-40 Lubricant		Required for hardware lubrication
Wire brush		Required for hardware cleaning
MINI-DUCTOR VENOM MDV-777		Automatically shipped one per retailer at no additional cost as SOA635186



For any service and support concerns, please visit their website [Induction Heating Tools - Induction Innovations](#) or reach out to them via phone at 877-688-9633. Their website also includes ‘how to’ and knowledge resources should you need assistance understanding how to use the Mini-Ductor tool.

IMPORTANT NOTE:

The coil included in the MINI-DUCTOR VENOM kit will require some modification to be performed prior to the service procedure. This is needed to provide optimum temperature during usage.



Continued...

Reprogramming Equipment Required for MANUAL TRANSMISSIONS ONLY		
Part Name	Image	Details
PC, DST-I and/or DST-010		Required for software reading and installation.
SSM4		
DCA-8000		Required to maintain battery voltage during the reprogramming procedure.

AFTERMARKET PROCESS

If a Technician encounters a vehicle affected by the WRA-25 recall equipped with non-OEM specification parts **or modified ECU software** that in some way prevent the retailer from performing recall, please refer to section 9.4.1 in the Claims Policies & Procedures Manual for additional information and repair order documentation and submit an NQR and an URFCAs outlined below.

1. Submit an NQR (Non -Quality Report), selecting the “To document a recall repair as directed by SOA in a recall/service campaign bulletin” reason, and use failure code WRA. All NQR submissions should contain specific details and photos as to what the retailer is encountering that is preventing them from completing the recall repair.
2. Submit an Urgent Request for Customer Assistance (URFCA), which can be found in the Service Operations & Technical menu on Subarunet. When completing the URFCAs, please select the Warranty does not apply reason type. The description should include detailed comments as to the non-OEM components or modifications that are preventing the retailer from completing the recall and the NQR#. Please attach a copy of the NQR when submitting the URFCAs.

NOTE: The NQR and URFCAs are being requested for documentation purposes only. While the recall will still remain open on these vehicles unless the owner brings the vehicle back to original specification, it is helpful in our reporting to the EPA and CARB.

COMPONENT CONFIGURATION:

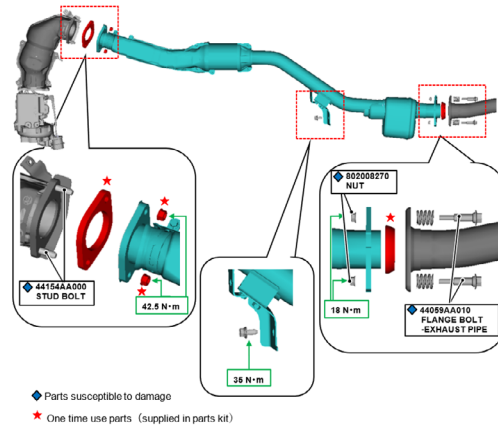

Continued...

SERVICE PROCEDURE:

For CVT-equipped vehicles, proceed to Step 2.

STEP 1: (MANUAL TRANSMISSION ONLY): Review the battery charging information supplied in the **APPENDIX A** section of this bulletin. Reprogram the ECM using the normal Flashwrite procedures. Once successfully reprogrammed, proceed to Step 2.

If the reprogramming is not successful contact Techline using TechShare to see if CID and CVN are factory. Use [Techline Case Submission Now Through TechShare Special Edition TechTIP](#) for instructions on submitting a CID and CVN case. Be sure to upload a project file that includes CID and CVN information. If immediate assistance is required for WRA-25 after the case has been started via TechShare, please call Techline directly for prompt support with CID and CVN confirmation as responds may take up to 24 hours.

If the CID and/or CVN are not factory, please document on the RO and advise the owner that they will need to return the ECM back to factory specification in order for the recall to be completed.

Caution: DO NOT proceed with center pipe replacement if it is determined that the ECM software has been modified. If the reflash cannot be performed due to modified ECM software, the retailer will not be reimbursed for the center pipe replacement, as this does not complete the recall.

This recall requires both the rear catalyst and ECM to be reflashed for manual vehicles. Completing one without the other results in an incomplete repair and will not be reimbursed, as it does not fulfill the recall requirements.

NOTE: Always note the original Calibration Identification number (CID) the vehicle came in with on the repair order **before** reprogramming and, make sure to list the **NEW** CID for any newly-installed programming (as confirmed from the actual control module **AFTER** installation). The **NEW** CID **MUST** also be noted on the repair order as this information is required for entry in the **Claims Specific Data area** during claim submission.

STEP 2: Prepare the coil attachment supplied in the MINI-DUCTOR VENOM tool by winding the coil five rotations around a 17mm socket. This will help optimize the heat application to the exhaust components.

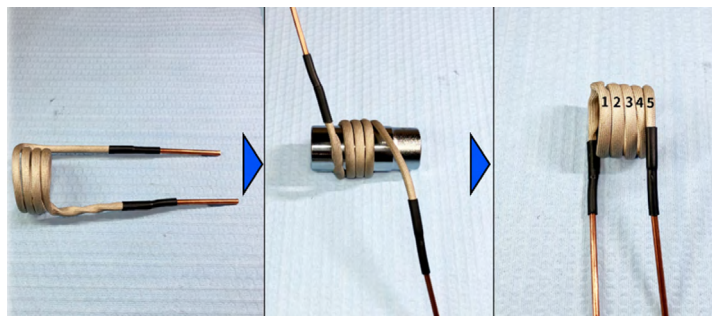

STEP 3: Raise the vehicle following the procedure specified by the lift manufacturer.

CAUTION: The vehicle exhaust components may be extremely hot after driving. If required, use protective safety equipment to prevent any burns or excessive heat exposure to the skin.

NOTE: If aftermarket parts are found that prevent the retailer from performing the recall, please refer to the **Aftermarket Parts Process** section on page 5 of this bulletin.

Continued...

STEP 4: Remove the lower engine/transmission cover.

STEP 5: Using a wire brush, remove all rust located on both nuts and studs of the front center exhaust pipe connection.

NOTE: The amount of rust may vary depending on the vehicle. The example image below is to be used as reference.

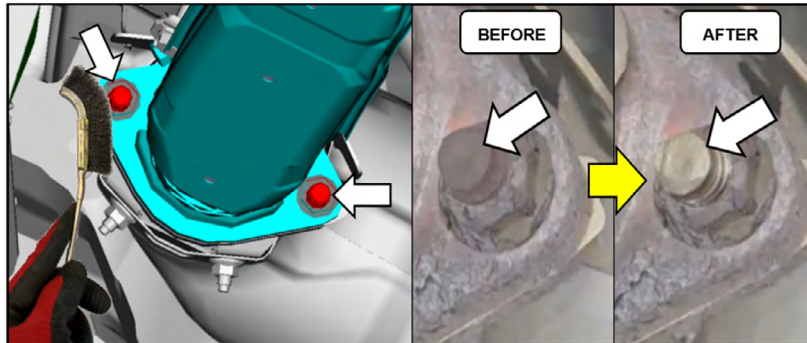

STEP 6: Using the MINI-DUCTOR VENOM, apply heat to the left side nut/stud for **1 MINUTE**.

CAUTIONS:

- **DO NOT** attempt to loosen the nut prior to applying heat.
- Use protective equipment such as heat resistant gloves and sleeves to prevent any burning of the skin.
- Continuous operation of the induction tool for a time period over 2 minutes may cause overheating and damage to the tool.
- If components become red hot, discontinue heat application and proceed to the next step.

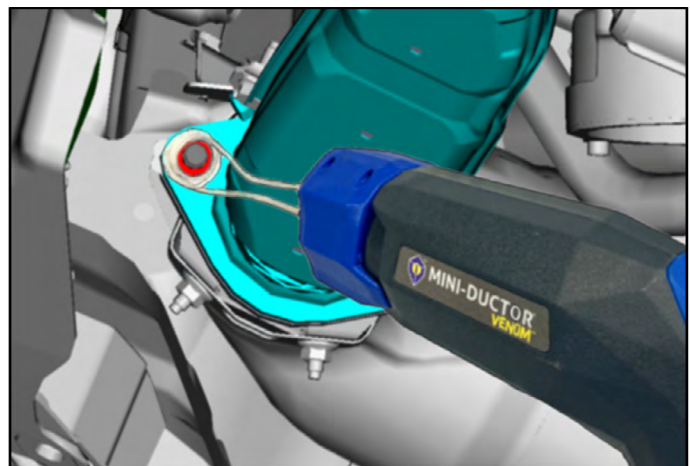

STEP 7: After the heat has been applied, **CAREFULLY** loosen the nut 15 degrees.

CAUTION: **DO NOT** attempt to loosen the nuts completely. This may cause nut to seize.

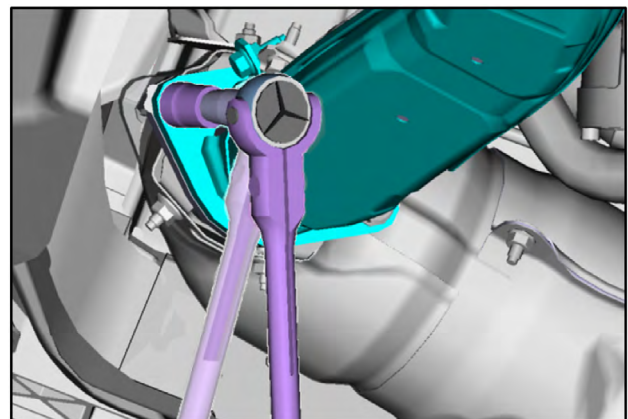

Continued...

NOTE: When encountering cases of the nut not loosening (exceeding a turning torque of 100 Nm (74ft-lbs), apply turning force in the clockwise direction, repeat the one minute heat application, and attempt to loosen again.

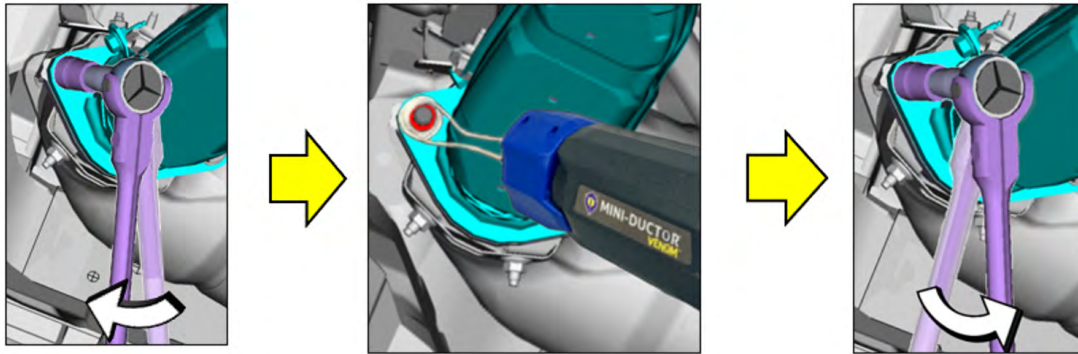

STEP

8: Always allow at least **1 MINUTE** of rest time for the MINI-DUCTOR VENOM to cool after usage. Apply heat to the right side nut/stud for **1 MINUTE**.

CAUTIONS:

- The duty cycle of the MINI-DUCTOR VENOM is one minute on and one minute off.
- Continuous operation of the induction tool for a time period over 2 minutes may cause overheating and damage to the tool.
- If components become red hot, discontinue heat application and proceed to the next step.

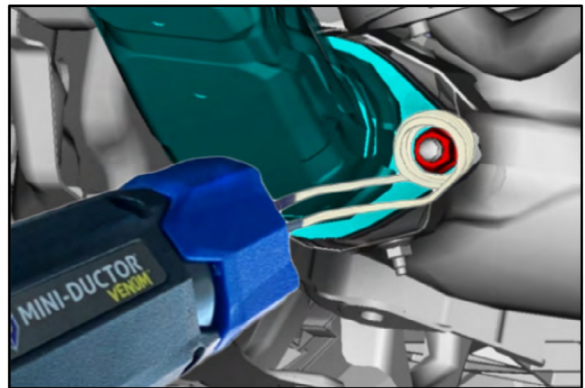

STEP 9: After the heat has been applied, CAREFULLY loosen the nut 15 degrees.

CAUTION: DO NOT attempt to loosen the nuts completely. This may cause nut to sieze.

NOTE: When encountering cases of the nut not loosening (exceeding a turning torque of 100 Nm (74ft-lbs), apply turning force in the clockwise direction, repeat the one minute heat application, and attempt to loosen again.

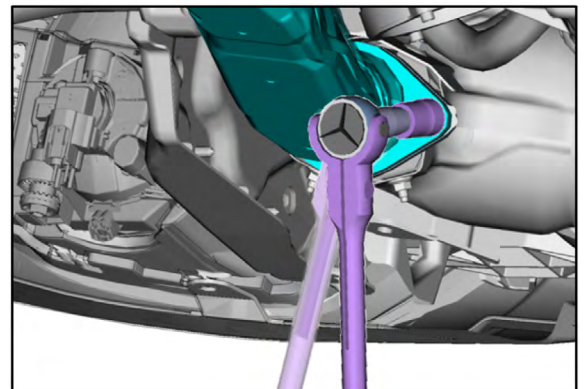

STEP 10: Using an air gun, apply shop air to both nuts for a period of 1 MINUTE to cool.

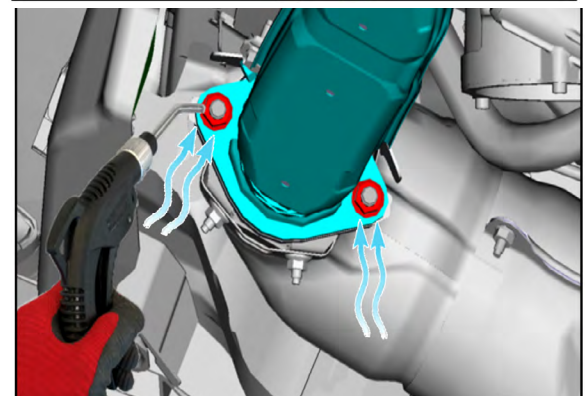

Continued...

STEP 11: Apply WD-40 lubricant to both the left and right stud/nuts.

CAUTION: If sufficient cooling of the components has not been met, the lubricant will evaporate and not penetrate effectively.

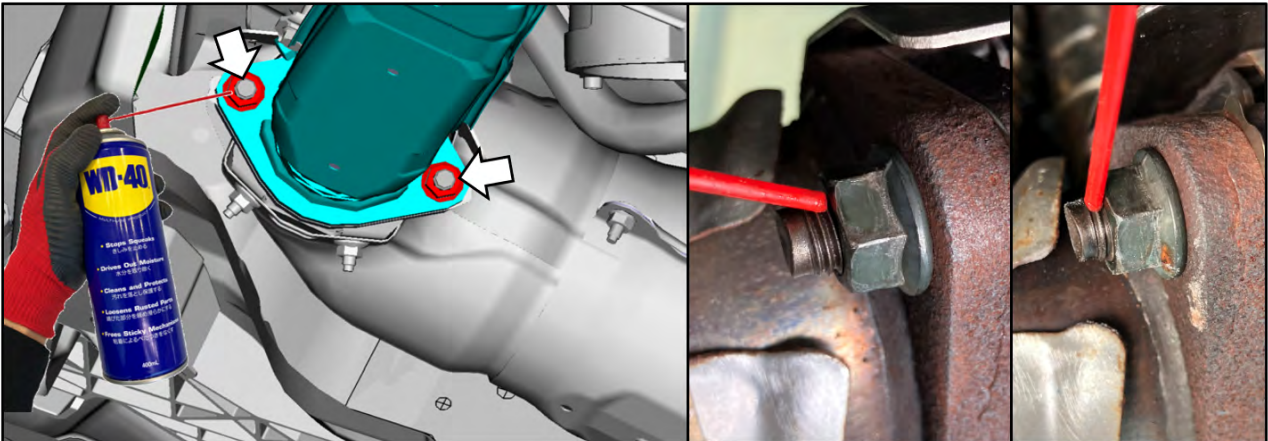

STEP 12: CAREFULLY loosen both nuts.

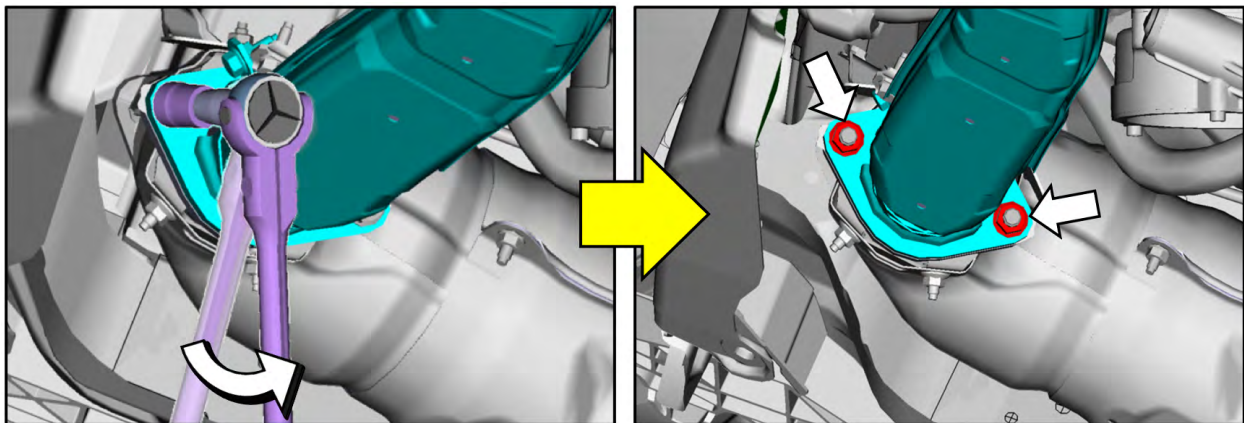

NOTE: When encountering cases of the nut becoming tight while loosening, slightly turn the nut in the clockwise direction, re-apply WD-40 lubricant, and loosen the nut. **PATIENCE IS KEY!**

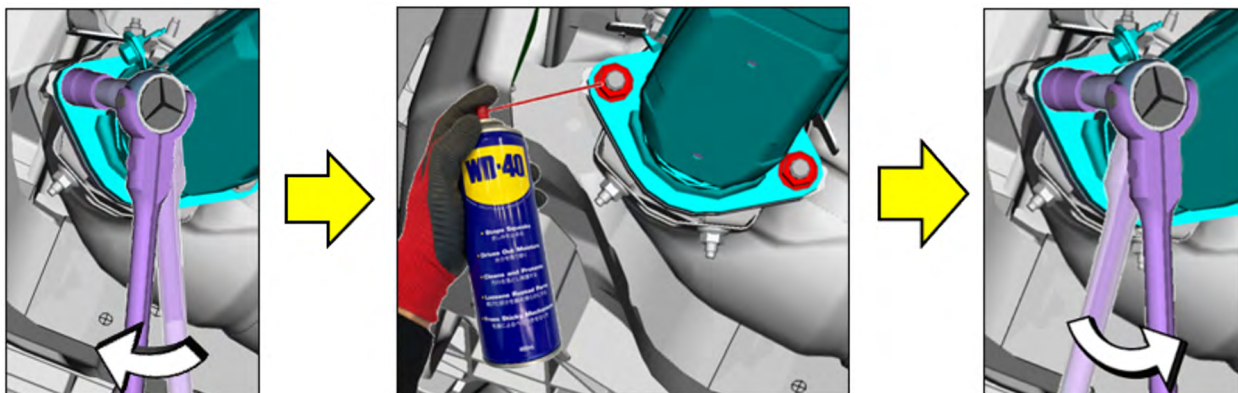

CAUTION: When encountering cases of the stud becoming excessively damaged during removal, replacement of the affected stud will be required. Refer to the service procedure outlined in the **APPENDIX B** section of this bulletin and then proceed to Step 14.

Continued...

STEP 13: Remove the rear flange mounting bolts and nuts and separate the exhaust.

NOTE: If needed, WD-40 and the wire brush can be used to aid in removal.

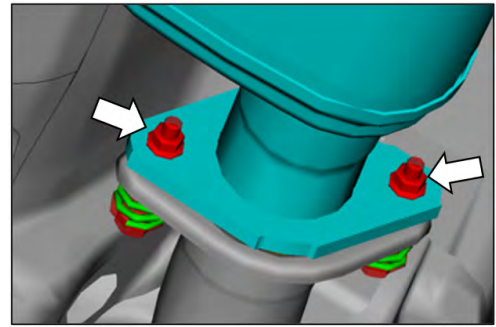

STEP 14: Remove the mounting bolt holding the center pipe to the hanging bracket.

NOTE: If needed, WD-40 and the wire brush can be used to aid in removal.

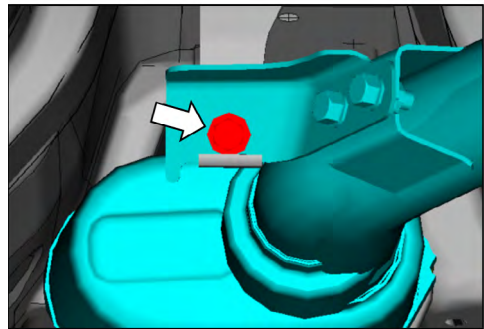

STEP 15: Remove the center exhaust pipe from the vehicle.

IMPORTANT: If excessive stud damage has occurred, refer to the **APPENDIX B** section of this bulletin. Once the additional service procedure is completed, continue to Step 15 below.

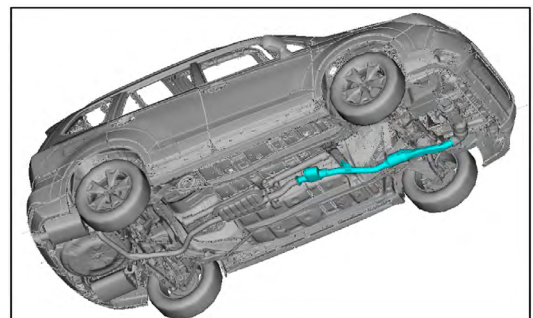

STEP 16: Clean and degrease the mounting studs.

STEP 17: Install the new exhaust gaskets supplied in the part kit.

STEP 18: Install the new exhaust pipe. Secure the pipe to the hanger bracket with the mounting bolt and torque to 35Nm (26ft-lbs).

STEP 19: Install the flange bolts, springs and new nuts. Torque to 18Nm (13ft-lbs).

STEP 20: Install the new mounting nuts to the front studs. Torque the nuts to 42Nm (31ft-lbs).

STEP 21: Remove the heat shield from the original center exhaust pipe.

STEP 22: Cut the catalytic converter into a 11 inch section. Refer to the image below.



Continued...

STEP 23: Prepare the catalytic converter for shipment using the 16in x 8in x 8in cardboard box provided with the replacement center exhaust pipe.

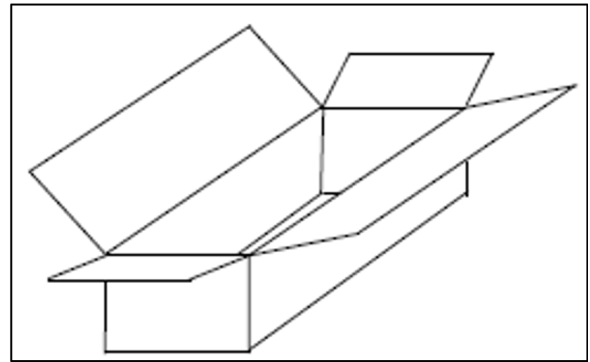

IMPORTANT: ONLY the box provided in the service kit PN is to be used for return shipping to the PCC. If the included return box is not available, a suitable replacement box not to exceed 18 in x10 in x10 in may be used. The retailer’s AR statement will be charged shipping costs for all other returned packaging types exceeding the dimensions listed above. A \$100 dollar processing fee will also be billed to the retailer’s AR statement for WRA-25 shipments exceeding these dimensions beginning September 1st, 2025. See TSB 09-51-08R for general converter return procedures.

STEP 24: Ship the catalytic converter section to the Parts Collection Center (PCC): **3701 David Howarth Drive Lafayette IN 47909** using only the specifically designated catalytic converter shipping account in the returns shipping portal. As is standard practice, a RO copy and a copy of the return request must accompany the part to avoid a potential debit of the claim.

Subaru of America>>RETURNS Routing Guide

Please enter your origin and destination below.

Please select the type of return

Enter Origin Zip Code:

Enter Destination Zip Code:

Enter Shipment Weight:

Any single package is greater than 130 inches in length and girth combined or is this on a pallet

Any single package is greater than 108 inches in length

Is the shipment 10 non stackable pallets (42" X 48") or greater or more than 750 cu ft or in excess of 20 Linear feet?

[How to Comply with Federal Hazardous Materials Regulations](#)

STEP 25: The heat shield and flanged ends can be discarded.

CALIFORNIA “VEHICLE EMISSION RECALL - PROOF OF CORRECTION” CERTIFICATE

The California Air Resources Board and the Department of Motor Vehicles Registration/Recall Program requires that all emission related Recall/Campaign or Service Program repairs be completed before a vehicle registration is renewed. Please provide owners of vehicles registered in the state of California a completed “Vehicle Emission Recall - Proof of Correction” certificate. Vehicle owners should be advised to retain this certificate because the California Department of Motor Vehicles may require they provide proof this service program repair has been completed. Additional certificates are available through normal parts ordering channels using part number MSA6P1301. Quantity 1 = 1 booklet of 50 certificates.

Vehicle Emission Recall - Proof of Correction				
License Number	Make	Year Model	Body Type	Vehicle Identification Number
	Manufacturer	Subaru of America, Inc.		Recall Number
The above described vehicle has been repaired, modified and/or equipped with new emission control devices to meet applicable California Emission Control Laws				
Dealer's Name		Address, City, State and Zip		
Date	Dealership's Authorized Signature			
	X			
Return this certificate to DMV only when required-otherwise retain for your records.				

Continued...

SERVICE PROGRAM IDENTIFICATION LABEL:

Type or print the necessary information on a Campaign Identification Label. The completed label should be attached to the vehicle’s upper radiator support. Additional labels are available through normal parts ordering channels. The part number is **MSA6P1302**, which comes as one sheet of 20 labels.

Part Number	Applicability	Description	Order Quantity
MSA6P1302	ALL MODELS	CAMPAIGN COMPLETION LABELS (CONTAINS ONE SHEET OF 20 LABELS)	1

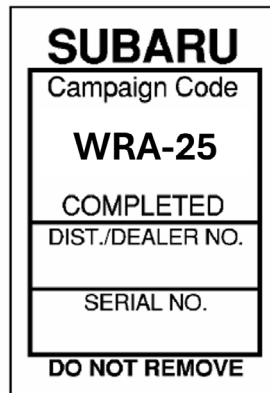

CLAIM REIMBURSEMENT AND ENTRY PROCEDURES:

Credit to perform this recall will be based on properly completed repair order information. Retailers may submit claims through Subarunet.com.

Labor Description	Labor Operation #	Labor Time	Fail Code
REAR CATALYST NON-COMPLIANCE - CVT	B106-301	0.7H	WRA-25
REAR CATALYST NON-COMPLIANCE – MT (INCLUDES ECM REPROGRAMMING)	B106-302	1.0H	

IMPORTANT REMINDERS:

- SOA strongly discourages the printing and/or local storage of service information as previously released information and electronic publications may be updated at any time.
- Always check for any open recalls or campaigns anytime a vehicle is in for servicing.
- Always refer to STIS for the latest service information before performing any repairs.

Continued...

APPENDIX A

BATTERY CHARGING INFORMATION: Subaru of America, Inc. (SOA) highly recommends utilizing either the Subaru Midtronics DCA-8000 Dynamic Diagnostic Charging System or the Subaru Midtronics GR8-1100 Diagnostic Battery Charger to the vehicle in the Power Supply Mode feature anytime a vehicle control module is being reprogrammed. Once the Midtronics charger is connected to the vehicle, if the battery is fully charged, it will take less than three (3) minutes to boot-up the charger, select the Power Supply Mode, and have the battery voltage stabilized and ready for reprogramming.

NOTES:

- For instructions on using the Power Supply Mode, reference the applicable User Manual for the Midtronics DCA-8000 Dynamic Diagnostic Charging System and the Midtronics GR8-1100 Diagnostic Battery Charger on STIS.
- Confirm all electrical loads such as lights, audio, HVAC, seat heaters, and rear defroster are all switched OFF before setting up the charger for Power Supply Mode.
- Select the correct battery type (Enhanced Flooded, Flooded, Gel, AGM or AGM Spiral).
- Input the CCA which matches the vehicle's battery. **NOTE:** OE and replacement batteries have different CCA ratings. Always confirm the battery's CCA rating before proceeding.
- If using a DCA-8000 Dynamic Diagnostic Charging System, set the power supply voltage to 13.5 Volts.
- DO NOT connect the DST-i or DST-010 until the Power Supply mode function has completed its battery test mode and the Charging Voltage has dropped to and shows a steady 13.5 Volts on the display.
- Once Power Supply Mode reaches a steady 13.5 Volts, connect the DST-i or DST-010 to the OBD connector and proceed with initiating the normal FlashWrite reprogramming process.
- Amperage will fluctuate based upon the vehicle's demand for power. **NOTE:** If the voltage rises beyond 14 Volts while programming is in process, the procedure will abort. This can indicate a need to test or charge the vehicle battery before any further attempt at programming is made.
- ALWAYS set the power supply voltage to 13.5 Volts when using Power Supply Mode. NEVER turn the ignition switch on when charging at voltages 15 Volts or higher.

REMINDER: If the DCA-8000 or GR8-1100 indicates the vehicle's battery must be charged, charge the battery fully before proceeding to reprogram the vehicle while using the Power Supply Mode.

NOTE: Control module failures resulting from battery discharge during reprogramming are not a matter for warranty. Should any DTCs reset after the reprogramming update is performed, diagnose per the procedure outlined in the applicable Service Manual.







VERY IMPORTANT: This information is applicable to the Subaru Midtronics DCA-8000 Dynamic Diagnostic Charging System and the Subaru Midtronics GR8-1100 Diagnostic Battery Charger **ONLY**. It does not apply to any other brand / type of "generic" battery charger whatsoever. **ONLY** the DCA-8000 and the GR8-1100 and their Power Supply Mode feature have been tested and approved by SOA.

Continued...

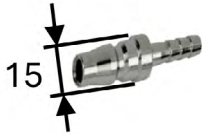
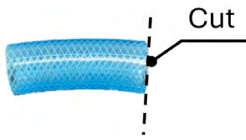
APPENDIX B

ADDITIONAL SERVICE PROCEDURES FOR STUD REMOVAL:

The following service procedures are to be applied when encountering difficulties removing the exhaust hardware resulting in damage to the stud(s). The procedures were developed to provide assist when removing seized hardware. Depending on the available equipment two different penetrate oil application methods have been outlined.

Additional Required Tools & Materials		
Tool Description	Image	Details
Vacuum brake bleeder (Option A)		Required for pulling lubricant through threads
Air hose nipple (Option A)		Required for pulling lubricant through threads
Rubber hose (Option A)		Diameter: 9/16-7/8 inch Length: 3 inch Required for pulling lubricant through threads
14mm deep socket (Option B)		Required for applying lubricant using pressure
Cushion tape (Option B)		Required for applying lubricant using pressure
Heat gun		Required for flange heat application
Pipe wrench or stud bolt remover		Required for turning stud
		

Continued...

STEP 1: Prepare the coil attachment supplied in the MINI-DUCTOR VENOM tool by winding the coil five rotations around a 27mm socket. This will provide the needed width for the heat application to the exhaust components.

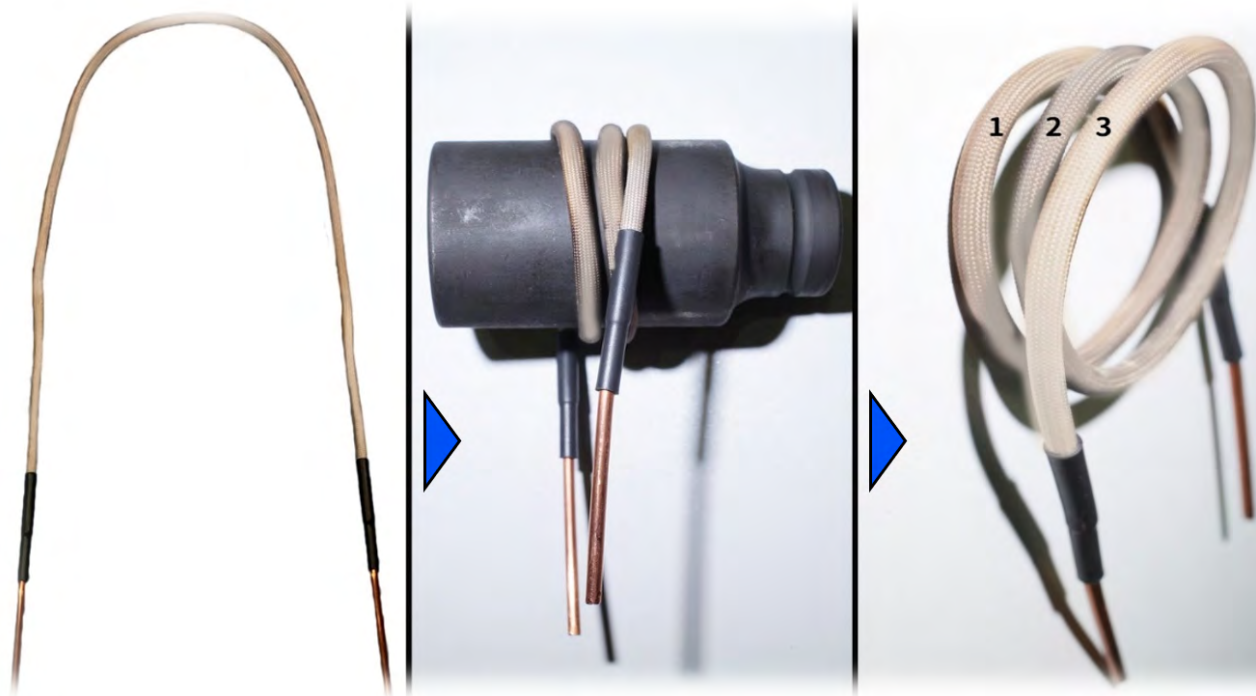

Caution:

The IH heater coil should be set to heat the base of the stud bolt and the front and back of the flange. If the heating method is incorrect, the target temperature (250° C) will not be reached, and the bolt will not loosen.

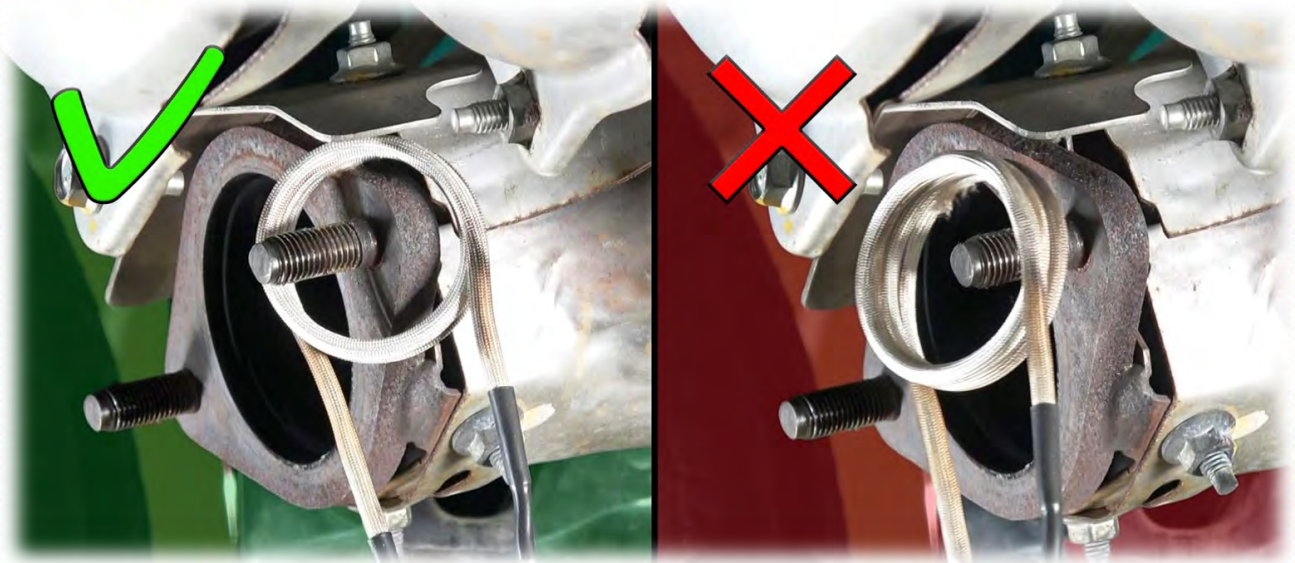

STEP 2: Remove the center exhaust pipe (service procedure Steps 12-14 reference). This will allow sufficient workspace.

Continued...

STEP 3: Using a heat gun, apply heat to the flange area for 3 MINUTES. Once completed, apply heat for 2 MINUTES using the MINI-DUCTOR VENOM.

CAUTION: DO NOT exceed heat application with the MINI-DUCTOR VENOM for more than 2 MINUTES.

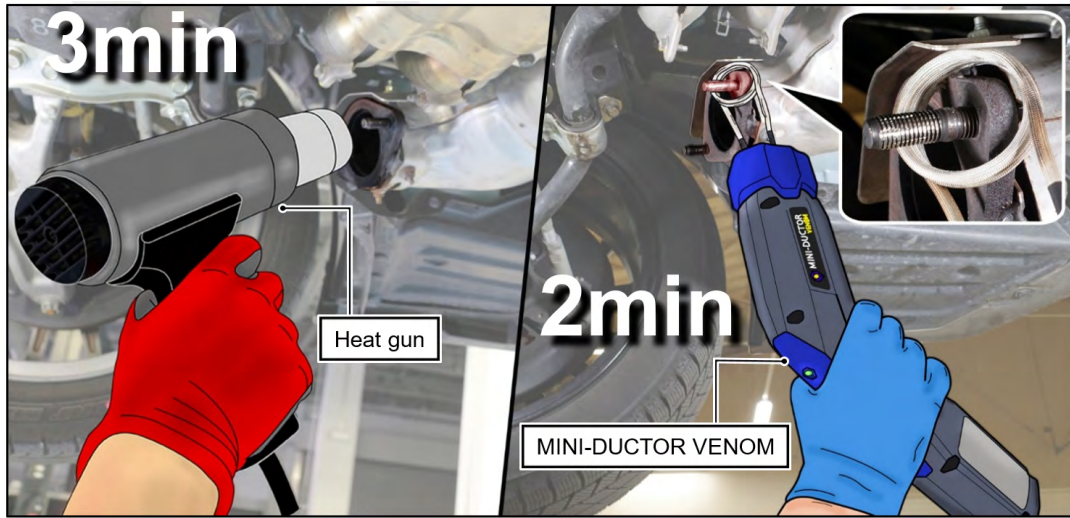

STEP 4: CAREFULLY loosen the heated stud using a stud remover or pipe wrench. Once the stud starts to turn, proceed to the next Step.

CAUTION: DO NOT fully remove the affected stud.

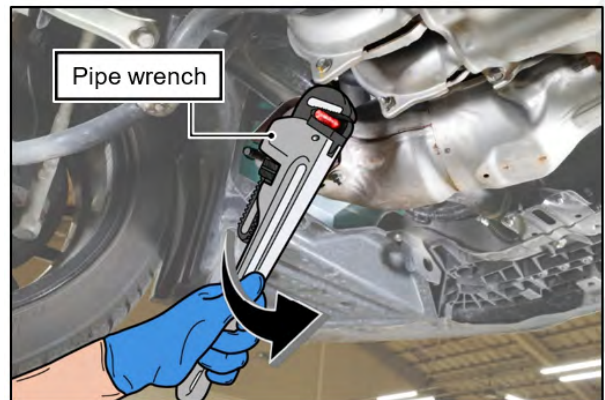
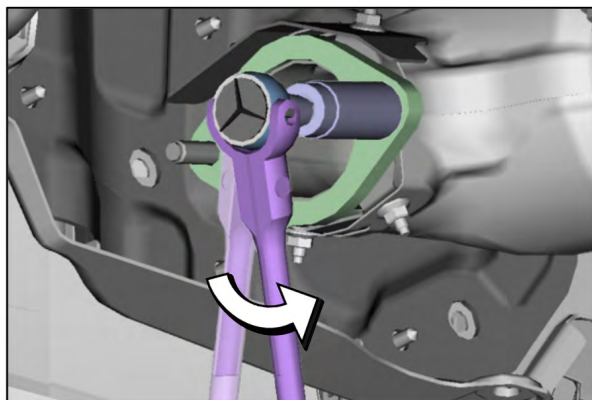

IMPORTANT: When encountering cases of the stud being unable to loosen, slightly tighten the stud, reapply heat, and re-attempt to loosen.

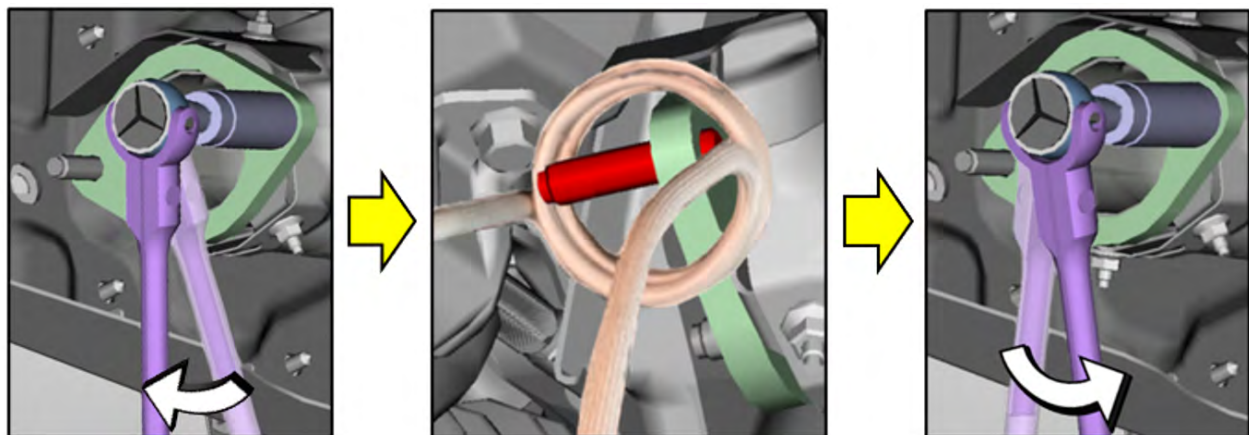

Continued...

STEP 5: Using an air gun, apply air to the affected area for **1 MINUTE**.

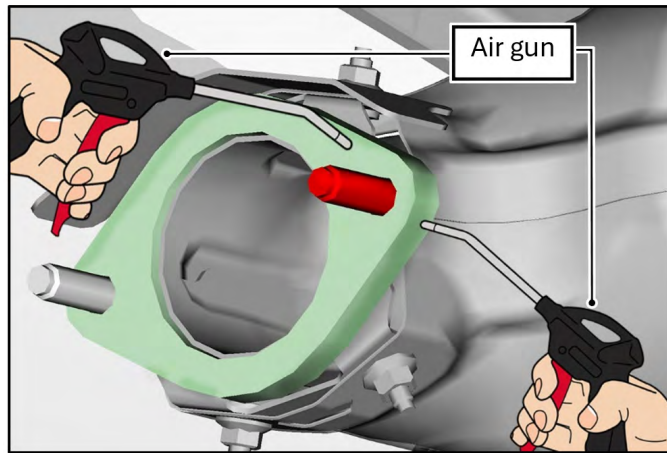

STEP 6: Depending on the available equipment, two methods have been provided for applying lubricant to the affected area. Option A requires the use of a vacuum brake bleeder and option B uses **a socket and an air gun** to apply the lubricant.

OPTION A:

1. Assemble the brake bleed hose tip, air hose nipple, and a hose cut with an outside diameter of 9/16-7/8 (15-21mm) and length of 3 inch (80mm).

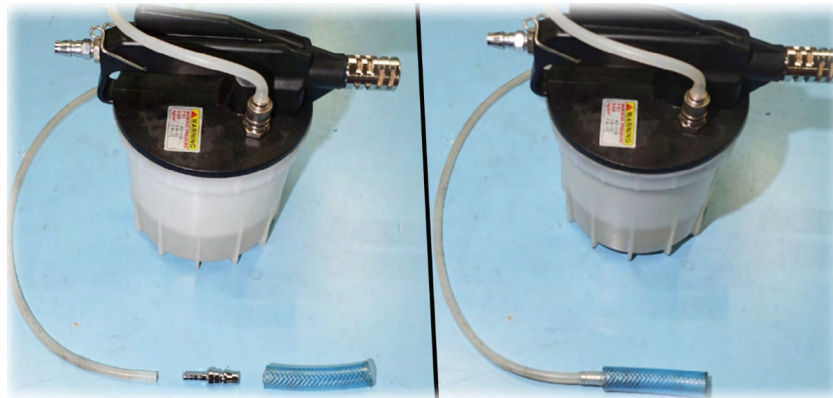

2. Apply vacuum to the affected stud. Maintain flush contact with the hose and flange to ensure sufficient vacuum.
3. Spray the lubricant (WD-40) on the opposite side of the flange to the stud threads. Once the lubricant has fully penetrated the threads, proceed to Step **7**:

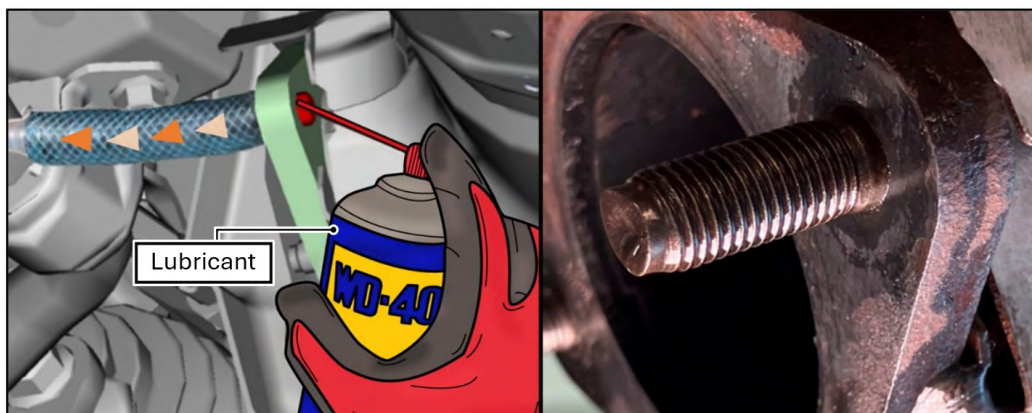

Continued...

OPTION B:

Prepare the socket and tap by applying the tape to face of the socket. Ensure the tape is fully wrapped to ensure a sufficient seal.



Apply lubrication (WD-40) to the exposed threads on the connection side of the flange.

Install the pre-prepared socket over the stud. Insert the air gun in the back of the socket and close all air gaps with a cloth or rag. While pressing the socket against the flange, Apply air to the socket. This pressure will allow the lubricant to penetrate the threads.

Repeat the lubrication process until lubrication is detected on the opposite side of the flange. Once sufficient lubrication has been confirmed, proceed to Step 7.



STEP 7: Using a stud remover or pipe wrench, **CAREFULLY** remove the affected stud.

CAUTION: If the stud becomes tight while removing, apply additional lubricant and continue removal.

STEP 8: Install the new stud (p.n. 44154AA000). Proceed to **Step 15** of the original service procedure.

IMPORTANT NOTE: If damage occurs to the front catalyst refer to part ordering/release information provided on the next page.

Continued...

PART RELEASE PROCESS:

In rare instances when the technician follows the repair procedure outlined in this bulletin and the front pipe requires replacement, the retailer should submit an order for the kit part number below and include the last eight characters of the VIN in the PO field. This kit includes a front converter, heat shields, an exhaust gasket, and 4 self-locking nuts.

Part Number	Description
X4461AB070	PIPE AY GSKT KIT FR

This part is on hold and all orders will be reviewed prior to the part being released.

NOTE: Failure to order to part correctly and not include the last 8 characters of the VIN in the PO field will directly result in your order being cancelled.

Once the appropriate part is received and the vehicle has been repaired, please submit a claim using the labor operations in the Claim Reimbursement and Entry Procedures section of this bulletin.

Continued...

This notice applies to the VIN identified in the address section printed below



Subaru of America, Inc.
P.O. Box 9103
Camden, NJ 08101-9877
844-373-6614
www.subaru.com

Subaru Service Program WRA-25
Voluntary Emissions Recall
June 2025

Dear Subaru Owner:

We would like to thank you for your selection of a Subaru vehicle. We take pride in our products and are committed to your continued satisfaction.

Subaru of America, Inc. (Subaru) is initiating a new voluntary emissions recall for certain 2017 model year WRX and Forester vehicles equipped with a 2.0L turbo engine. You have received this notice because our records indicate that you currently own one of these vehicles.

REASON FOR THIS VOLUNTARY EMISSIONS RECALL

The performance of the rear catalyst may cause your vehicle to exceed exhaust emission standards.

REMEDY

Subaru will replace the rear catalyst with an improved one on all affected vehicles. Subaru will also reprogram the Electronic Control Unit (ECU) on affected vehicles equipped with a manual transmission. This repair will be performed at no cost to you.

WHAT YOU SHOULD DO

Please contact your Subaru retailer for an appointment to have this repair performed at no cost to you.

HOW LONG WILL THE REPAIR TAKE?

The actual time to replace the rear catalyst is approximately 45 minutes. For vehicles equipped with a manual transmission, an additional 20 minutes will be required to reprogram the ECU. Your retailer can provide you with a better estimate of the overall time for this service visit, as it may be necessary to make your vehicle available for a longer period of time for scheduling purposes.

CALIFORNIA REGISTERED OWNERS

The California Air Resources Board requires that emission-related campaigns be completed prior to California's vehicle registration renewal process; without this repair, you will not be able to register your vehicle during your next annual registration. Upon completion of this campaign, your California dealer will complete and provide you a "Proof of Correction Certificate."

Continued...

If required, present the certificate to the California Department of Motor Vehicles (the "DMV") when renewing your California registration as proof of campaign completion. If the DMV does not request the certificate, we recommend that you keep it for your records.

In addition, the State of California requires that every vehicle must pass an emission test (SMOG Check) every two years and before it is sold. Without the service we are providing at no charge, your vehicle may not pass this test. In order to ensure your full protection under the emission warranty provisions, it is recommended that you have your vehicle serviced as soon as possible. Failure to do so could be determined as lack of proper maintenance of your vehicle.

CHANGED YOUR ADDRESS OR SOLD YOUR SUBARU?

If you have moved or sold your vehicle, please go to <https://www.subaru.com/support/customer-support.html> to send us your information.

IF YOU NEED FURTHER ASSISTANCE:

To locate the nearest Subaru retailer, you can access our website at www.subaru.com and select 'Find a Retailer.' For additional information, please go to: <http://www.wra25.service-campaign.com>.

If you need additional assistance, please contact us directly:

- By e-mail: Go to www.subaru.com, Customer Support and select 'Contact Us'
- By telephone: 1-844-373-6614
Monday through Friday between 8:00 a.m. and 7:00 p.m. ET
- By U.S. Postal mail: Write us at Subaru of America, Inc.,
Attn: Customer Advocacy Department,
P.O. Box 9103, Camden, NJ 08101-9877

Please contact us immediately if the Subaru retailer fails or is unable to make the necessary repairs free of charge. Your continued satisfaction with your Subaru is important to us. Please understand that we have taken this action in the interest of your vehicle's proper operation. We sincerely apologize for any inconvenience this matter may cause and urge you to schedule an appointment as soon as possible to have this repair performed.

Sincerely,
Subaru of America, Inc.

A subsidiary of SUBARU CORPORATION