



GROUP	MODEL
ELE	2025MY K4 (CL4)
NUMBER	DATE
385	August 2025

TECHNICAL SERVICE BULLETIN

SUBJECT: **BODY DOMAIN CONTROLLER (BDC) REPLACEMENT (CA2507)**

This bulletin provides information regarding the Body Domain Control unit (BDC) on certain 2025MY K4 (CL4) vehicles manufactured from June 1, 2024 through May 1, 2025. Due to a communication issue between the key fob and the BDC, the affected vehicles may exhibit a NO START condition when the ignition 'START' button is pressed accompanied by the inability to move the shifter out of the Park (P) position; however, all other Key Fob functions such as the Lock/Unlock, Trunk Release, Alarm and Remote Start continue to operate normally. Follow the procedure outlined in this publication to replace the Body Domain Control unit 'BDC'. Before conducting the procedure, verify that the vehicle is included in the list of affected VINs.



NOTICE

A Technical Service Bulletin is a field fix repair program without customer notification that may be performed during the warranty period.

This bulletin should only be performed with valid customer complaint of vehicle not starting when pressing the 'START' Button and/or the vehicle does not recognize key fob.

Repair status for a VIN is provided on KDealer+ (Service → Warranty Coverage → Warranty Coverage Inquiry). **If CA2507 is complete, subsequent or follow-up concerns must be addressed according to normal Service/Warranty Guidelines.**

A printed copy is for reference only; publication information can be updated at any time. Always refer to KGIS for the latest information. After logging in kdealer.com, the newest technical publications are listed in 'Service Releases' and has the latest service information that has been released.

Repair Procedure:

ⓘ IMPORTANT

Customer complaint of the vehicle not start when pressing the 'START' button and/or the vehicle does not recognize the key fob **MUST** be stated in the opening RO and Claim Notes.

ALL keys MUST be present at the time of the Smart Key Code Saving procedure. Any keys NOT present will NOT be programmed to the vehicle and will be inoperable.

1. Disconnect the negative (-) battery terminal (A).

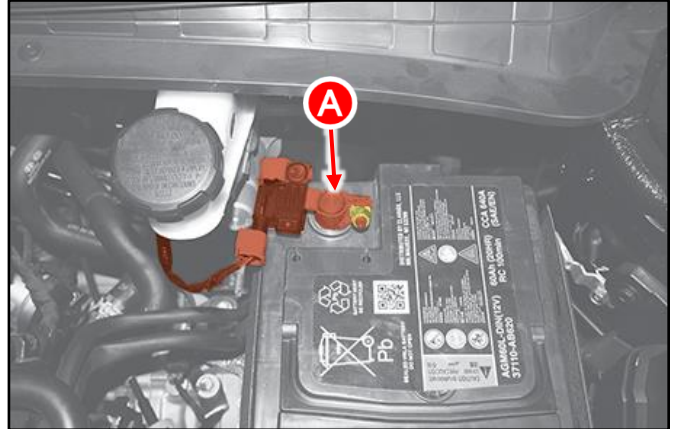

2. Remove the front weather strip (B) from the right front door opening.



3. Remove the floor console button panel (C).

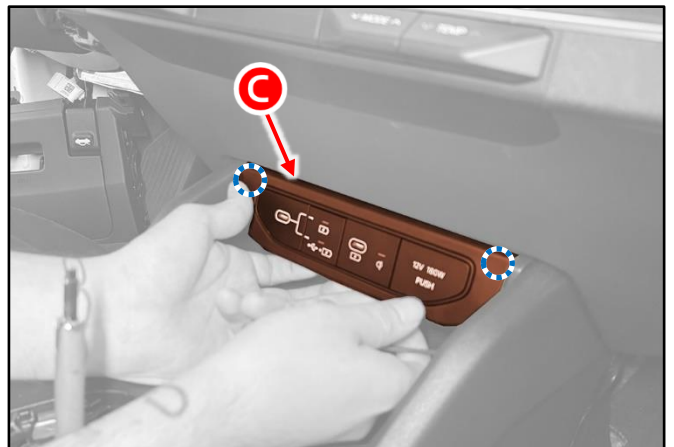

SUBJECT:

BODY DOMAIN CONTROLER (BDC) REPLACEMENT (CA2507)

4. Remove the floor console assembly (D) by referring to "Body (Interior / Exterior / Electrical) → Floor Console → Floor Console Assembly → Removal and Installation" in the applicable Shop Manual on KGIS.

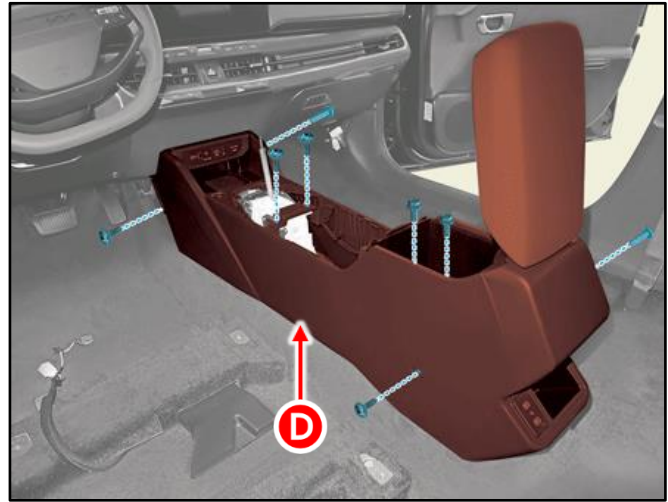

Note: Front seats removed for illustration purposes only.

Note: It is not necessary to remove the two (2) console screws (E).

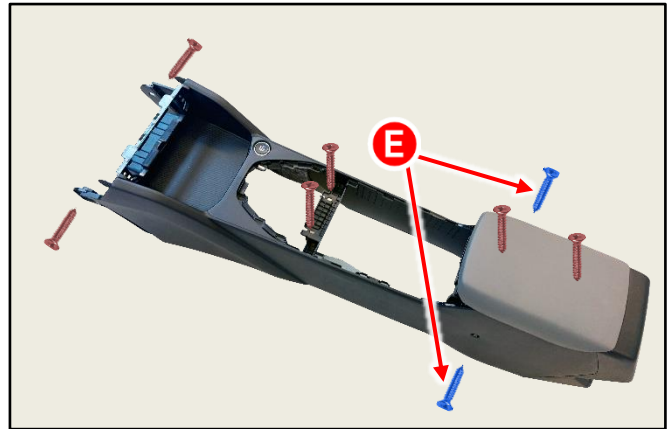

- 5a. Disconnect the floor console extension connector (F).
- 5b. **If equipped**, disconnect the wireless power charger (WPC) connector (G).

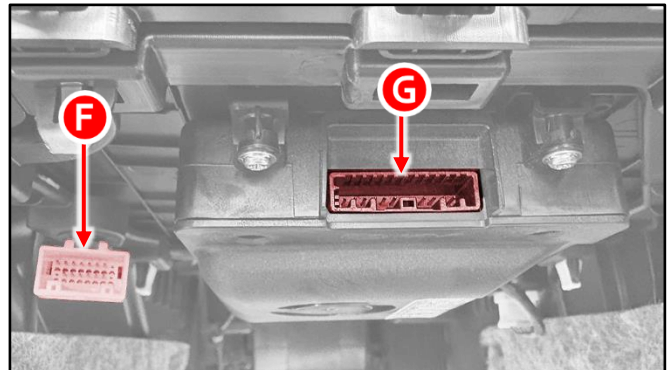

6. Remove the screw and detach the two (2) retaining clips at the top right corner of the crash pad lower panel (H).

Note: The crash pad lower panel (H) does NOT need to be removed.

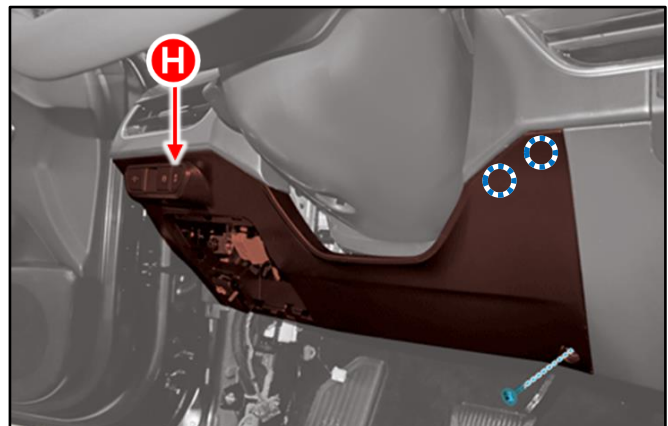

- 7. Remove the upper steering column cover (I).



- 8. Remove the right side crash pad side cover (J).

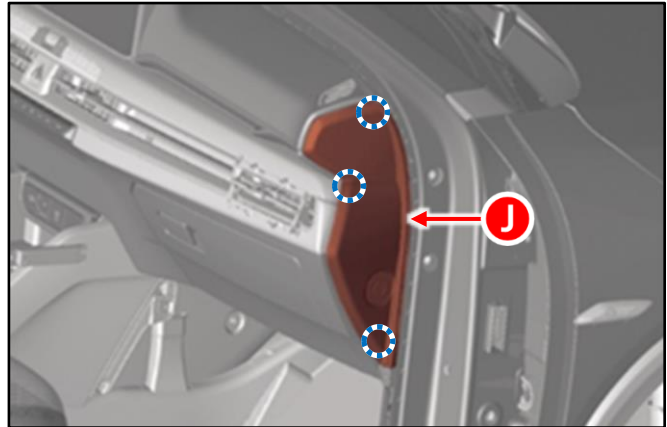

- 9a. Disengage the four (4) retaining clips to remove the hazard switch cover (K).

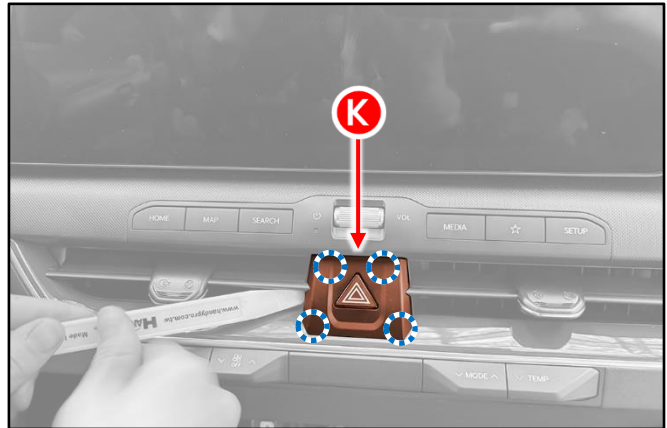

- 9b. Loosen the screw to remove the crash pad lower garnish (L).

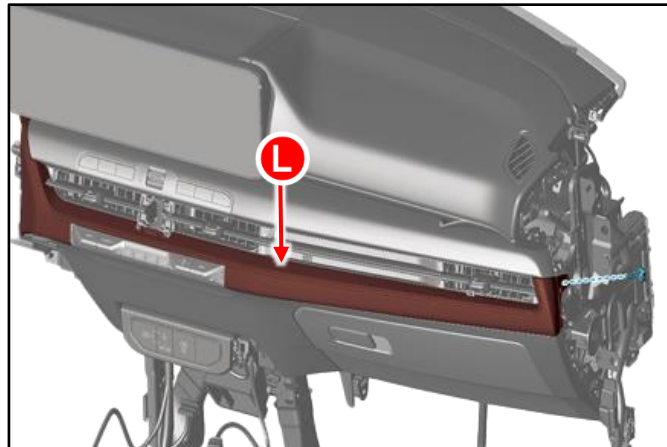

SUBJECT:

BODY DOMAIN CONTROL (BDC) REPLACEMENT (CA2507)

10. Loosen the five (5) screws to remove the crash pad air vent (M).

**TECH TIP**

The crash pad upper garnish (N) does NOT need to be separated from the crash pad air vent (M).

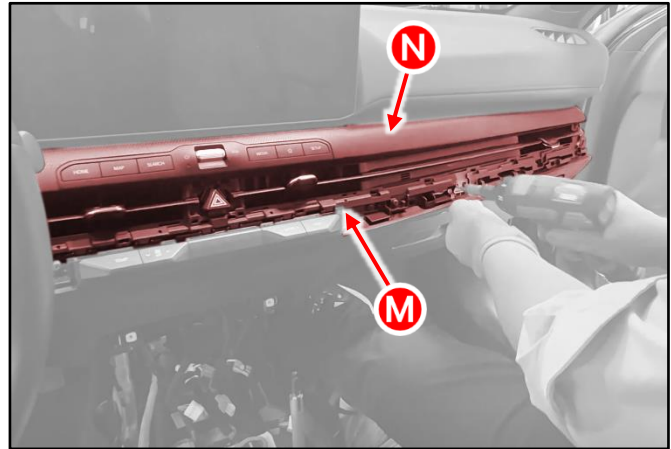

11. Loosen the two (2) screws to remove the heater and air conditioning controller (O).

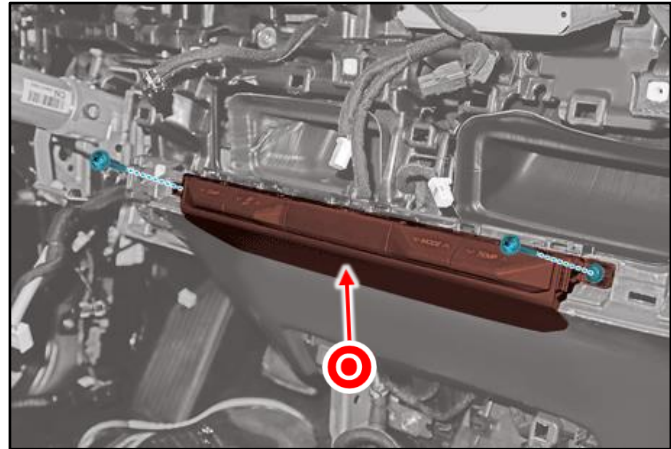

12. Remove the glove box (P) by referring to "Body (Interior / Exterior / Electrical) → Crash Pad → Glove Box → Removal and Installation" in the applicable Shop Manual on KGIS.

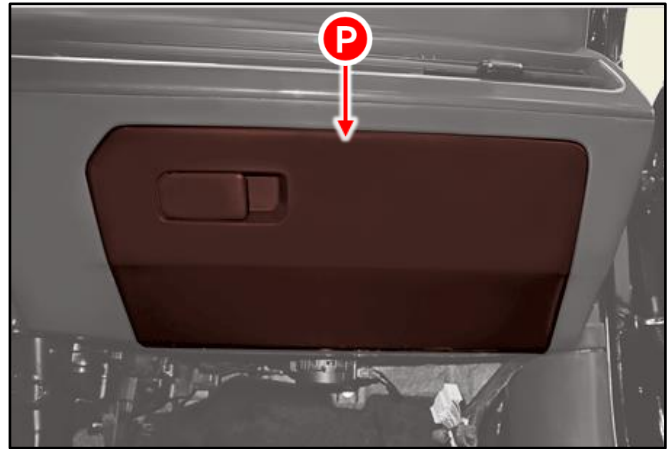

13. Loosen the five (5) nuts and nine (9) screws to remove the crash pad center panel (Q).

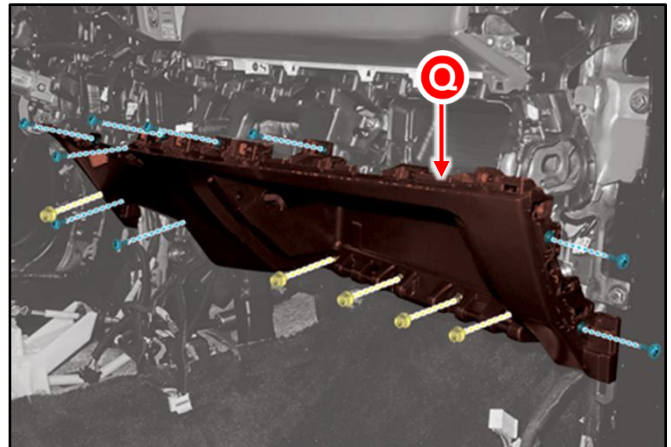

SUBJECT:

BODY DOMAIN CONTROLER (BDC) REPLACEMENT (CA2507)

- 14a. Remove the bracket (R) connecting the ccNC unit to the BDC unit.



Tightening torque for nut/bolt:
4.8 - 7.3 lb.ft (6.6 - 9.9 N.m)

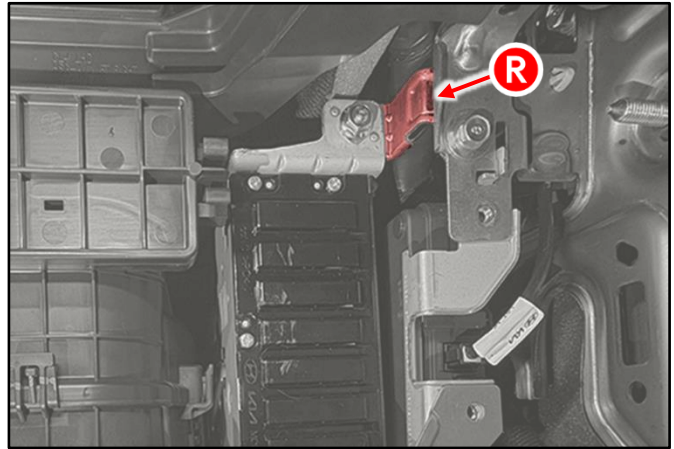

- 14b. Loosen the two (2) bolts and nut to remove the connected car navigation cockpit unit 'ccNC' (S).



Tightening torque for nut/bolt:
5.1 - 8.0 lb.ft (6.9 - 10.8 N.m)

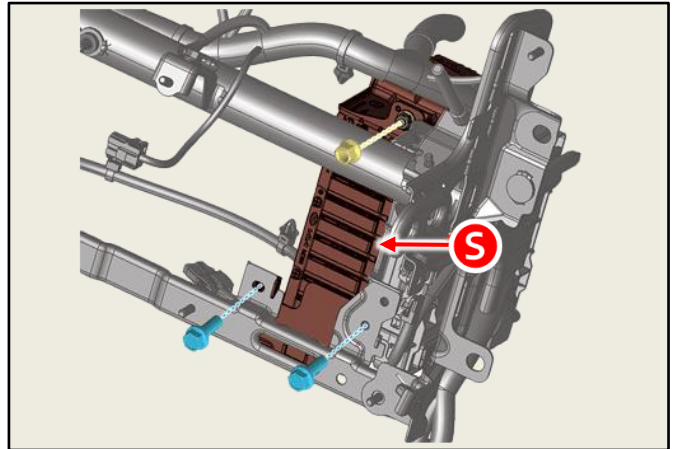

- 14c. Release the wiring harness clips at the top ccNC unit bracket to allow for additional slack.

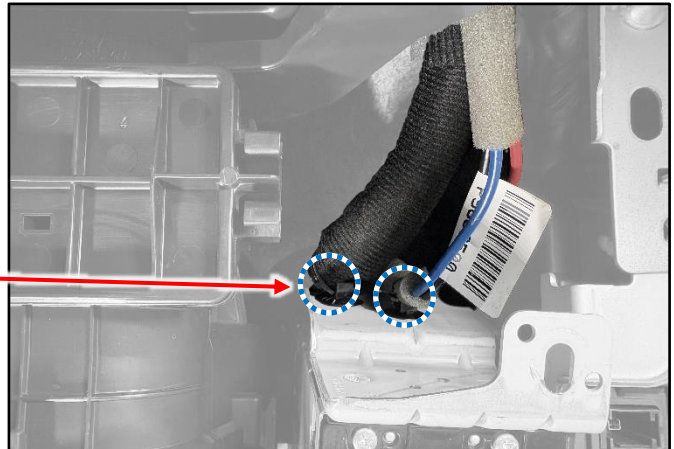

- 14d. Lower the ccNC unit (S) and then disconnect the connectors.

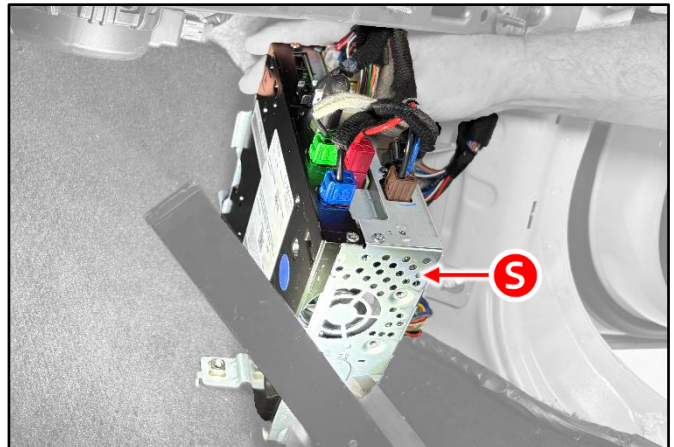

SUBJECT:

BODY DOMAIN CONTROL (BDC) REPLACEMENT (CA2507)

- 14e. Route the wiring harness (T) through the cowl cross bar assembly as shown.

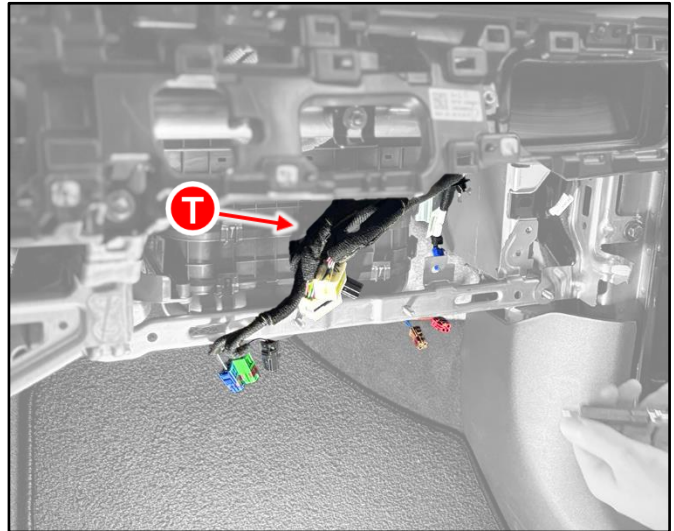

15. Disconnect the antenna (U) and related connectors from the BDC (V).

NOTICE

The antenna does **NOT** need to be removed from the vehicle.

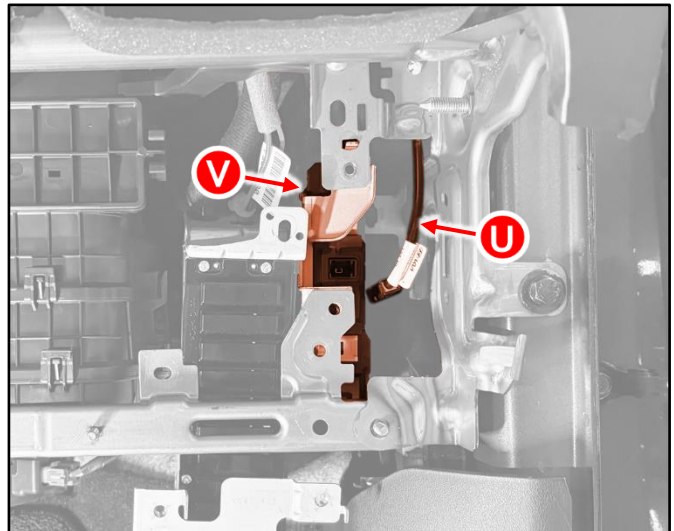

16. Loosen the two (2) BDC (V) retaining bolts and replace the BDC with a new part.

TECH TIP

Remove the BDC by lowering underneath the cowl cross bar assembly.

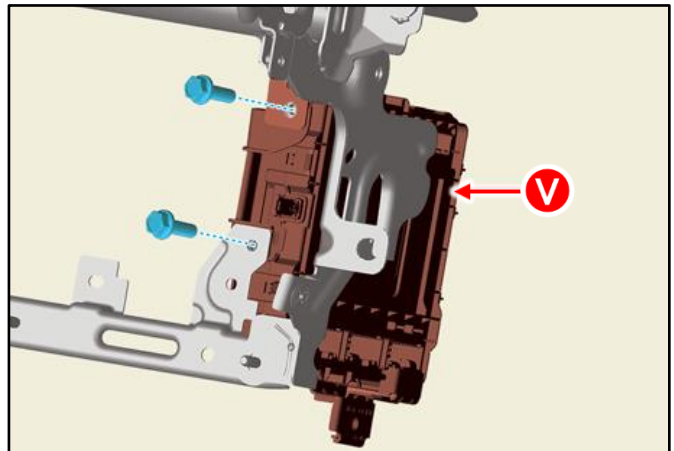

Tightening torque for nut/bolt:
4.8 - 7.3 lb.ft (6.6 - 9.9 N.m)

17. Reinstall all other removed parts in reverse order of removal.

Additional KDS Procedures:

① IMPORTANT

Using KDS, perform the following steps outlined in pages 8-10.

Note: Some models may not require that all KDS function operation be performed/completed.

- 18. Using the KDS 2.0, perform the **Variant Coding** by referring to “Expert Diagnosis → S/W Management → BDC-BCM - Body Domain Controller-Body Control Module → Variant Coding”.

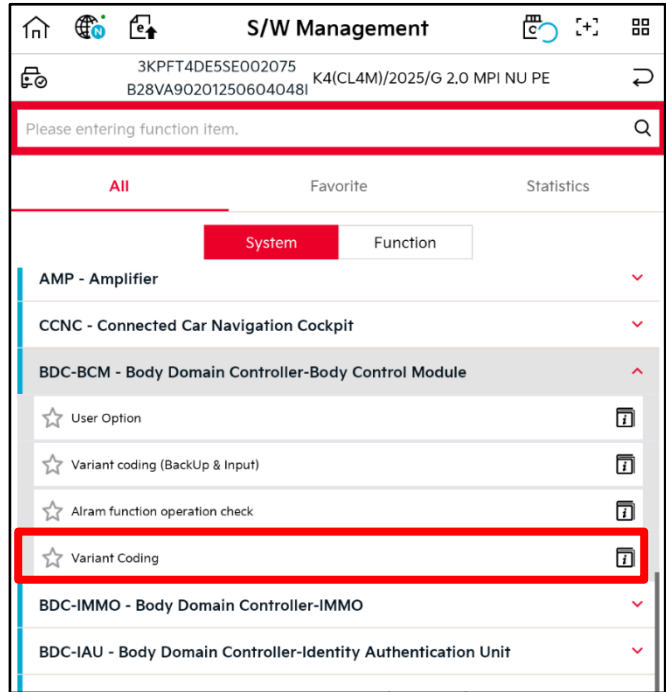

- 19a. Using the KDS 2.0, perform the **Smart Key Code Saving** by referring to “Expert Diagnosis → S/W Management → BDC-SMK - Body Domain Controller-Smart Key (ESCL) → Smart Key Code Saving”.

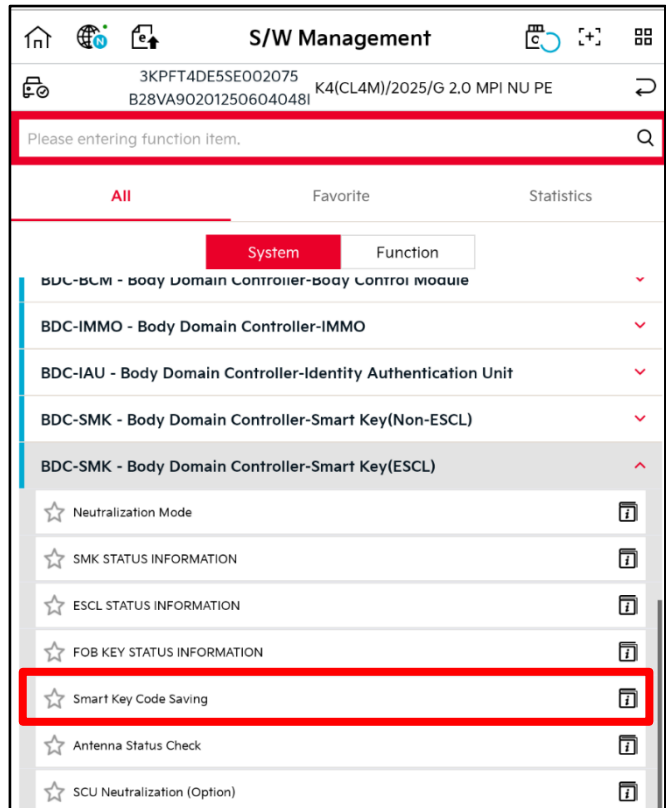

SUBJECT:

BODY DOMAIN CONTROLER (BDC) REPLACEMENT (CA2507)

- 19b. Retrieve the **PIN Code** by referring to “KDealer+ → Vehicle Info → Search Key/PIN Code”.

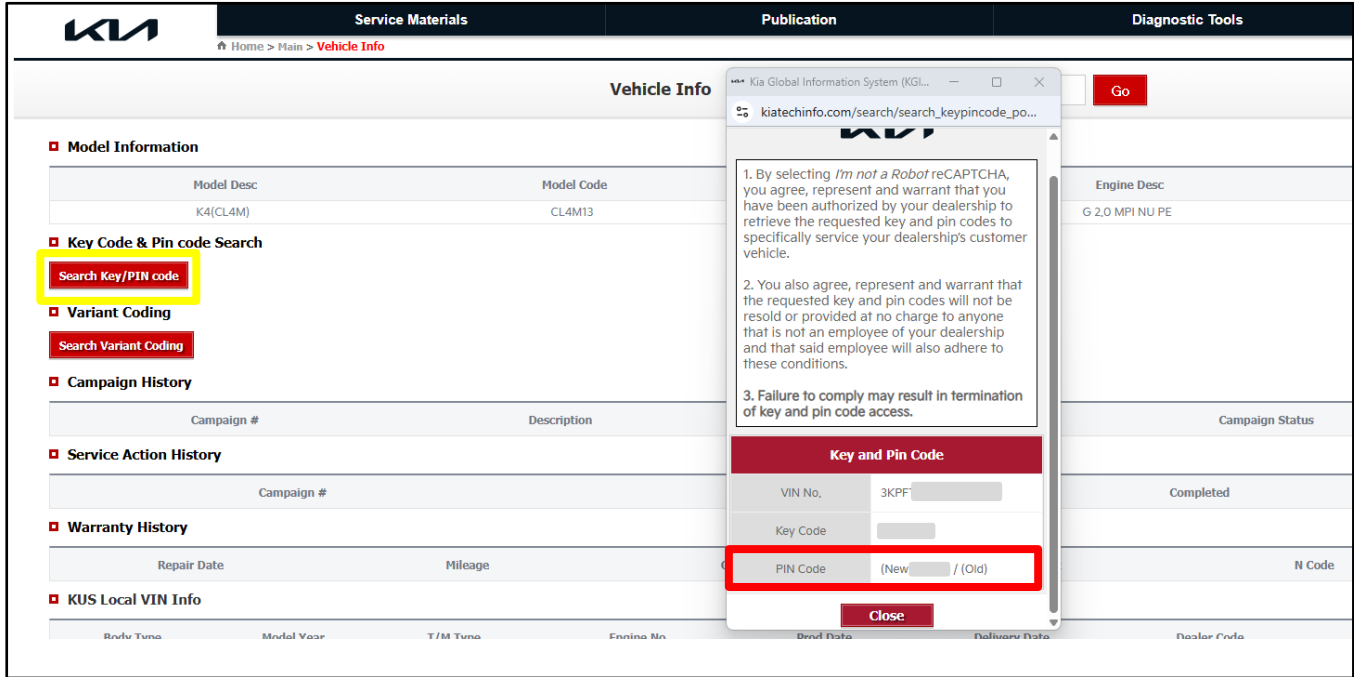

- 19c. Input PIN code and select 'OK'.

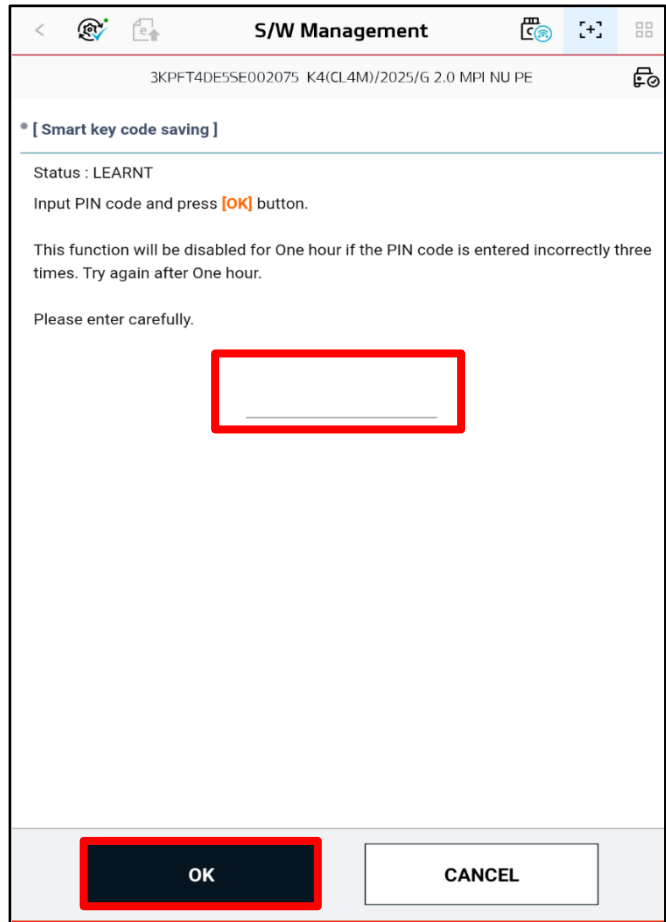

SUBJECT:

BODY DOMAIN CONTROLLER (BDC) REPLACEMENT (CA2507)

- 20. Using the KDS 2.0 and TPMS Communication Interface (SST# GITGOTKNMK01 or GITOTKDNN200), perform the **TPMS ID Writing** by referring to "Expert Diagnosis → S/W Management → BDC-TPMS - Body Domain Controller-Tire Pressure Monitoring System → Wheel Sensor ID Writing".

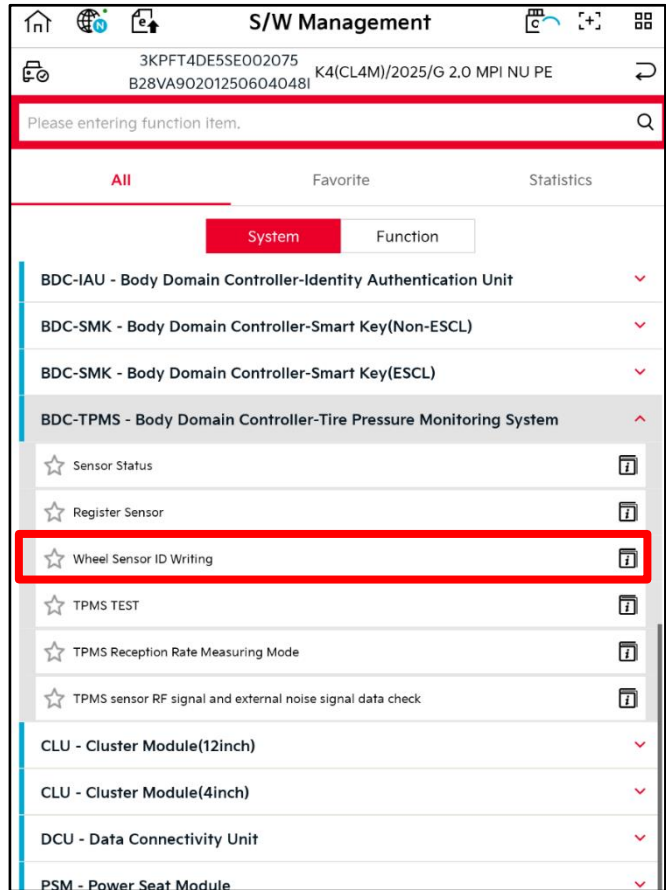

- 21. Using the KDS 2.0, performing the **Learning Mode** by referring to "Expert Diagnosis → S/W Management → BDC-IAU - Body Domain Controller-Identity Authentication Unit → Learning Mode".

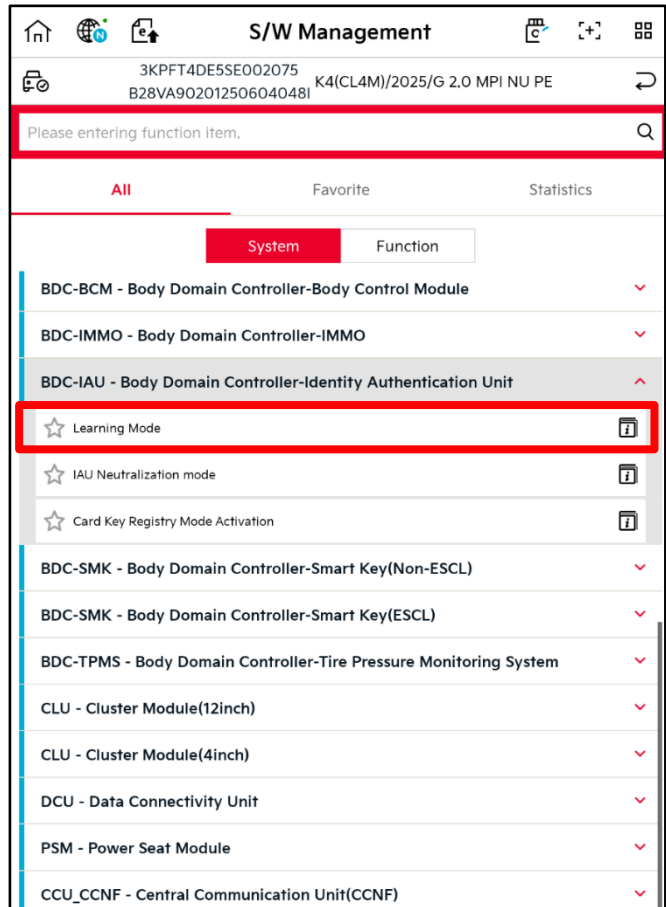

- 22. If applicable, perform Over The Air (OTA) controller S/W update with KDS 2.0.

- 23. Confirm normal vehicle operation.



SUBJECT:

BODY DOMAIN CONTROLLER (BDC) REPLACEMENT (CA2507)**AFFECTED VEHICLE RANGE:**

Model	Production Date Range
K4 (CL4)	June 01, 2024 to May 01, 2025

REQUIRED TOOL:

Tool Name	Part Number	Figure	Comments
Kia Diagnostic System (KDS)	N/A		KDS + VCI
TPMS Communication Interface	GITGOTKNMK01 Or GITOTKDNN200		Located SHOP

REQUIRED PART:

Part Name	Part Number	Figure	Qty.
Body Domain Controller (BDC)	95400 GG101QQK		1
	95400 GG201QQK		1

Note: The replacement part numbers will require a VIN entry for parts ordering. DO NOT order these parts for stocking purposes, related to this Customer Action. Supply is very limited. Until part supply stabilizes, please confirm availability before scheduling customers. Please be sure to expedite warranty filing.

SUBJECT: **BODY DOMAIN CONTROLER (BDC) REPLACEMENT (CA2507)**

WARRANTY INFORMATION:

N Code: N99 C Code: C99

Claim Type	Causal P/N	Qty.	Repair Description	Labor Op Code	Op Time	Replacement P/N	Qty.
V	95400 GG100	0	Body Domain Control Unit (BDC) Replacement	250M08R0	1.8 M/H	95400 GG101QQK Or 95400 GG201QQK	1

Note: The Operation Code listed above accounts for the time required to complete all the steps outlined in this repair procedure. Technicians must verify and perform all applicable KDS updates. Please note that some updates may not apply to the specific VIN. When substitute transportation is provided, manually enter sublet code 'X2' for rental expense reimbursement or one roundtrip rideshare expense.

