

July 21, 2025

Version 1

Burning Oil Smell at Cylinder Head

AFFECTED VEHICLES

Year	Model	Trim Level	VIN Range
2023–24	Pilot	ALL	ALL
2025	Pilot	2WD	VIN 5FNYG2...SB000021 thru 5FNYG2...SB025921
2025	Pilot	AWD	VIN 5FNYG1...SB000035 thru 5FNYG1...SB110425

SYMPTOM

Burning oil smell from under hood and/or MIL comes on with DTC P2096 and/or P2270.

POSSIBLE CAUSE

Porosity in the cylinder head cover bolt hole may cause oil to weep out onto Bank 1 (Rear Cylinder Head) catalytic converter and oxygen sensor. Some cases will turn on the MIL, setting DTC P2096 and/or P2270.

CORRECTIVE ACTION

Inspect for an active leak. If necessary, replace the OCV assembly bolts with **one time use sealing bolts**, or replace the cylinder head.

WARRANTY CLAIM INFORMATION

Operation Number	Description	Flat Rate	Defect Code	Symptom Code	Template ID	Failed Part Number
1105E0	Inspect cylinder head with borescope and oxygen sensor for oil leak (includes DTC clear)	0.7 hr	07601	05101	A25006A	12301-6FB-305
A	Repair procedure A: one time use sealing bolts install	0.4 hr			A25006B	
B	Repair procedure B: Replace the rear cylinder head, one time use sealing bolts	7.3 hr			A25006C	
C	Repair procedure C: Replace the bank 1 O2 sensor	0.1 hr				

CUSTOMER INFORMATION: The information in this bulletin is intended for use only by skilled technicians who have the proper tools, equipment, and training to correctly and safely maintain your vehicle. These procedures should not be attempted by “do-it-yourselfers,” and you should not assume this bulletin applies to your vehicle, or that your vehicle has the condition described. To determine whether this information applies, contact an authorized Honda automobile dealer.

PARTS INFORMATION**Repair Procedure A: Oil Control Valve Sealing Bolt Installation**

Part Name	Part Number	Quantity
BOLT, FLANGE (SEAL) 6X50	90012-6FB-A00	2

Repair Procedure B: Replace the Rear Cylinder Head

Part Name	Part Number	Quantity
GENERAL ASSY., RR. CYLINDER HEAD	06123-6FB-305	1
GASKET, RR. CYLINDER HEAD	12261-6FB-A01	1
GASKET, CAM END COVER	12411-6FB-A01	1
PLATE, RR. CAM END (CAM END REAR PLATE)	12512-6FB-A00	1
O-RING (4.8X1.9) (O-RING)	15142-PE0-000	2
FILTER ASSY., SPOOL VALVE	15815-6S9-A01	1
FILTER ASSY., VTC	15855-6S9-A01	1
PIPE SET, FUEL JOINT (FUEL JOINT PIPE) (MSDS)	16012-6FB-305	1
CLIP, INJECTOR (INJECTOR CLIP)	16451-6B2-A01	3
SEAL SET, INJECTOR	16453-6FB-A00	1
GASKET, IN. MANIFOLD (GASKET)	17055-6S9-A01	2
GASKET, IN. MANIFOLD	17101-6FB-A01	6
GASKET, EX. CHAMBER (NIPPON LEAKLESS)	18115-5G0-A01	1
GASKET, EX. PIPE (NOK)	18212-SA7-003	2
GASKET, PRE CHAMBER	18393-SDB-A00	1
GASKET, RR. WATER PASSAGE	19412-P8A-A02	2
SENSOR, AIR FUEL RATIO (DENSO)	36542-6FB-A01	1
BOLT-WASHER (12X188)	90005-5G0-A01	2
BOLT-WASHER (12X163)	90005-PAA-A01	6
WASHER, SPECIAL (8MM)	90006-6S9-A00	1
BOLT, FLANGE (10X56)	90164-TYA-A50	2
BOLT, FLANGE (10X40)	90169-TYA-A00	2
BOLT, FLANGE (10X30)	90171-TBA-A00	1
NUT, SELF-LOCK (8MM)	90212-RCA-A01	4
NUT, SELF-LOCK (10MM)	90212-SA5-003	9
O-RING (28.5X1.9)	91302-6S9-A11	2
O-RING	91311-5A2-A01	1
O-RING (31.2X4.1) (NOK)	91314-PH7-003	1
O-RING (15X1.9)	91333-PNA-003	2
NUT, FLANGE (8MM)	94050-06080	2
BOLT, FLANGE (SEAL) 6X50	90012-6FB-A00	2

Repair Procedure C: Replace the Bank 1 O2 sensor

Part Name	Part Number	Quantity
RR Oxygen Sensor	36542-6FB-A01	1

REQUIRED MATERIALS

Note: For Repair Procedure B only.

Part Name	Part Number	Quantity
Honda Genuine Motor Oil 0W-20	08798-9036	5.2 L (5.5 US qt.)
Honda All Season Antifreeze/Coolant Type 2	OL999-9011	9.3 L (2.46 US gal.)
Hondabond HT Silicone Gasket	08718-0004	1 tube per vehicle

TOOL INFORMATION

Part Name	Part Number	Quantity
Cam Holder	07AAB-6S9A100	1
Tool Injector Set Seal	070AG-5A0A100	1
Cam Seal Installation Tool	07AAD-6S9A100	1

INSPECTION PROCEDURE

Inspection Overview

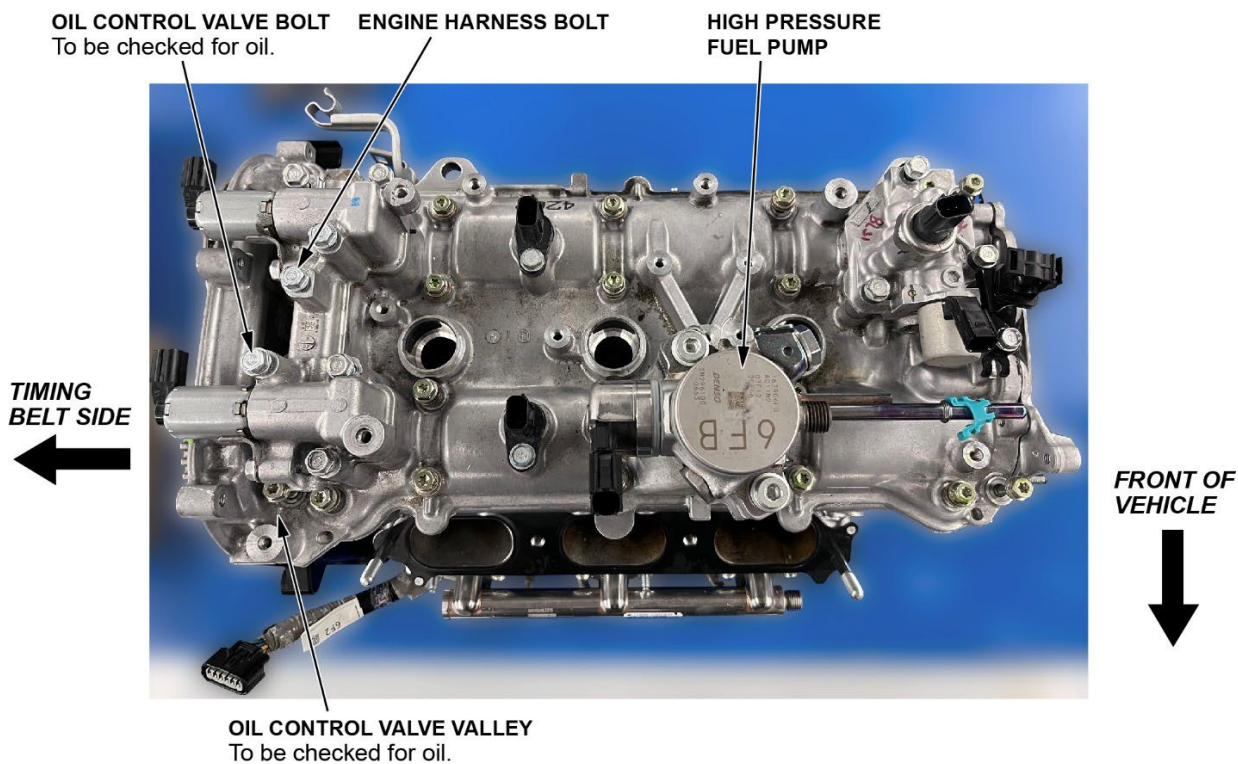

Inspection Steps

1. Unbolt the [air cleaner box housing](#).

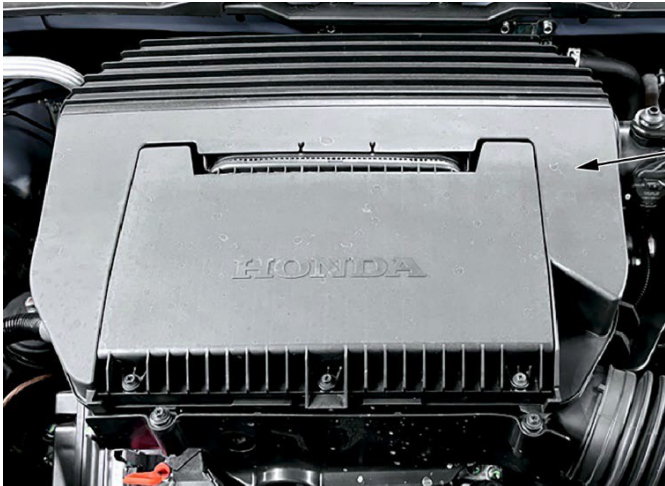

**AIR CLEANER
BOX HOUSING**
Unbolt.

2. Move air flow chamber stay assembly.

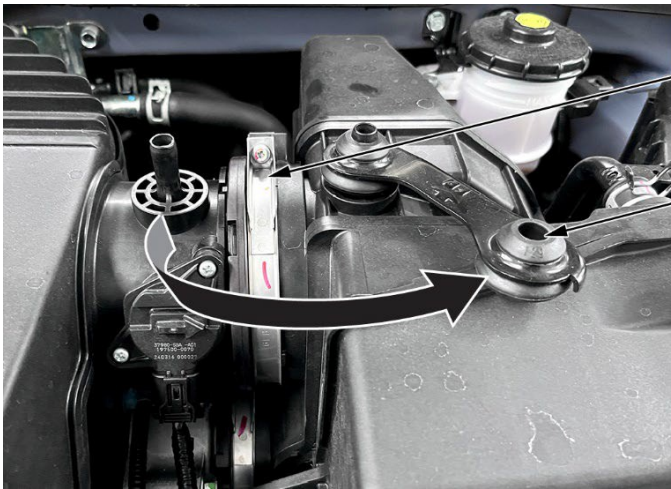

HOSE CLAMP
Loosen.

**AIR FLOW CHAMBER
STAY ASSEMBLY**
Swing over.

3. Move air cleaner box forward to access the bank 1 harness.

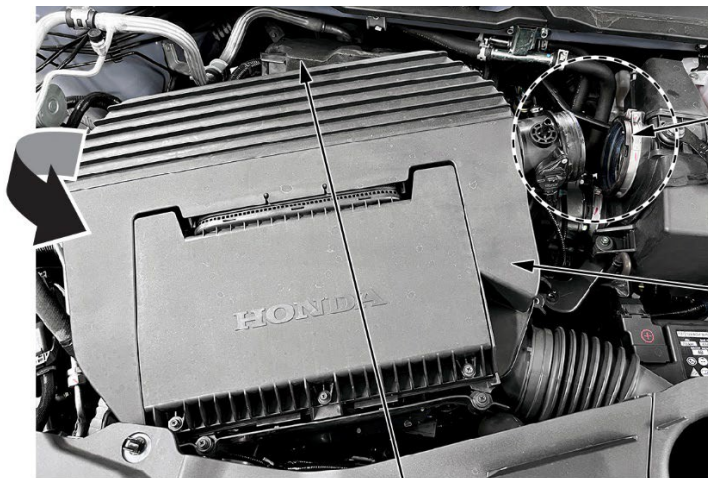

AIR CLEANER BOX
Disconnected.

AIR CLEANER BOX
Pivot just enough to
reach engine harness.

ENGINE HARNESS

4. Remove the bolts at bank 1 engine harness bracket, then move the harness away from oil control valve assembly.



BOLT
12 N·m
(9 lb-ft)

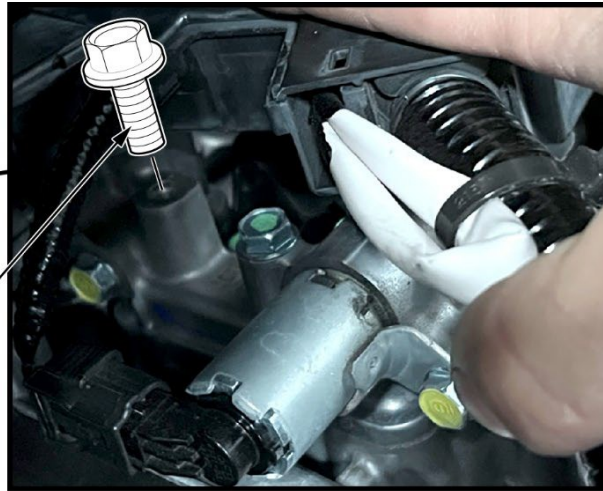

5. Remove the bolt from the oil control valve assembly.

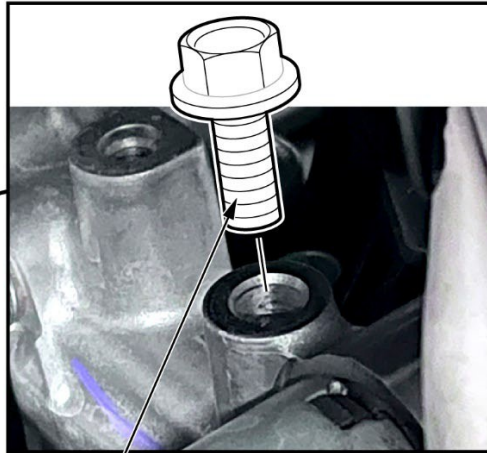

ENGINE HARNESS BOLT
12 N·m (9 lb-ft)

6. Position borescope at the bolt hole opening on the oil control valve assembly.

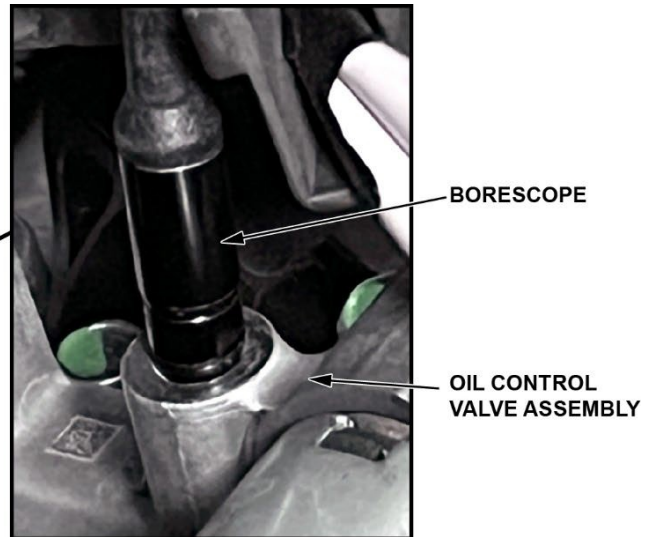

7. Check for signs of oil in the bolt hole and note if oil was present.
8. Use Spray brakes parts cleaner into bolt hole and surrounding areas to prevent corrupting the following test. Once cleaned, continue to next step.
9. Confirm MAF and MAP sensors are plugged in.
NOTE: If not plugged in, the test will not function correctly.
10. Connect the i-HDS to the DLC connector.
11. Perform PGM-FI VCM function test and check for PGM-FI DTCs with the i-HDS **3 times**.

Program pathway: Vehicle Selection > System Selection > PGM-FI> Function Test > VCM Test

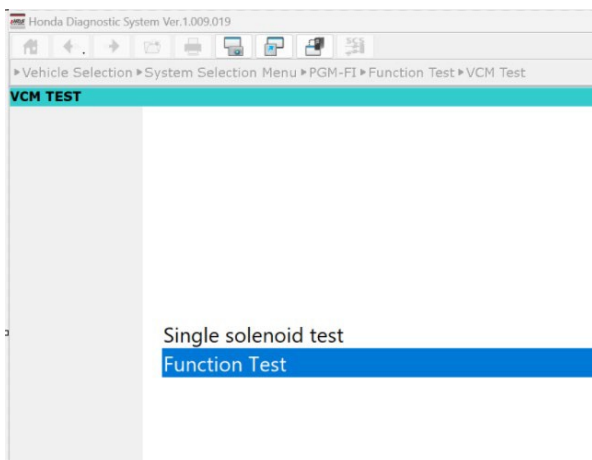

12. Check the bolt hole for oil leak:

- If oil is found, proceed with Repair Procedure A.
- If oil is not found, proceed to the next step.

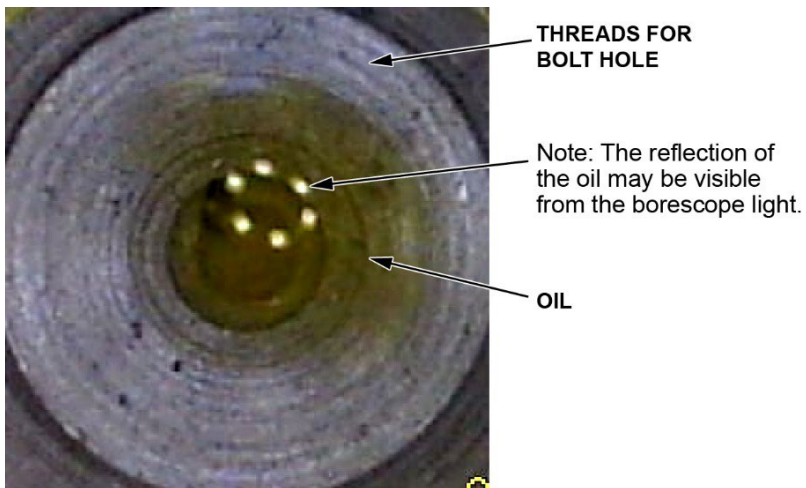
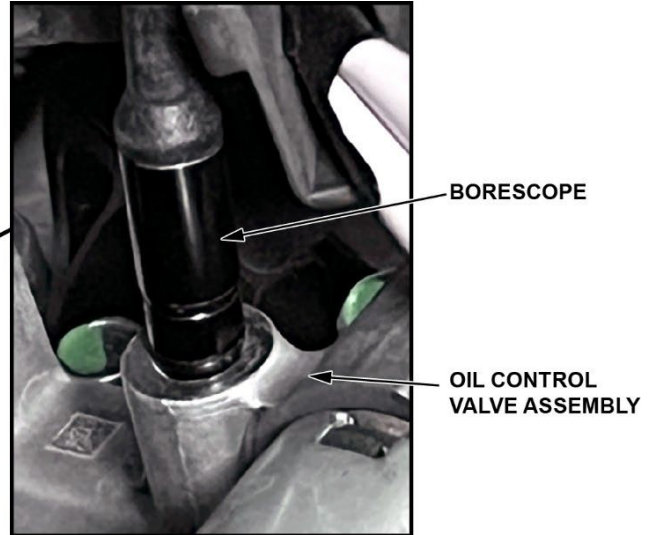

13. Move the borescope to the valley between the oil control valve assembly and the timing belt cover. If an oil leak is found in the valley, proceed to **Repair B: Bank 1 Head Replacement**.
- If an oil leak is not found, proceed with Repair procedure A
 - If an oil leak is found, proceed with Repair procedure B



Look for oil here.

14. If DTC P2096 and/or P2270 is found along with an oil leak; replace the bank 1 secondary oxygen sensor.

REPAIR PROCEDURE A – OIL CONTROL VALVE SEALING BOLT INSTALLATION

1. Remove air filter housing.
2. Unbolt Bank 1 branch of the engine harness and move from engine.

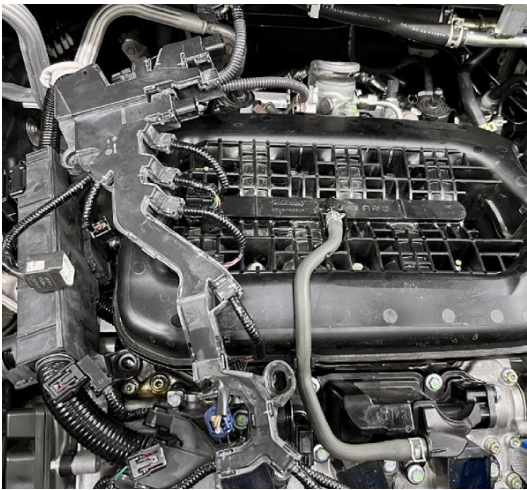

3. Remove the two oil control valve (OCV) bolts shown below and replace them with the new sealing bolts.

NOTE:

- OCV holder gasket **must be replaced** if all original bolts are loosened and/or removed prior to install of updated sealing bolts.
- Installing bolts in incorrect locations may damage the cylinder head cover, leading to a cylinder head replacement.

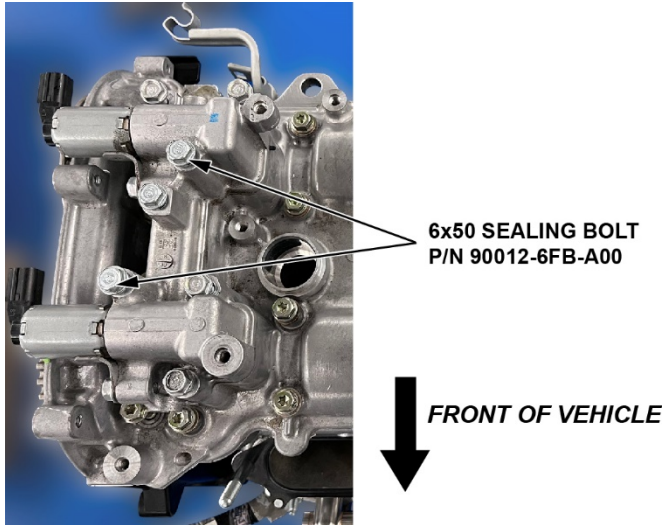

4. Reconnect the engine harness over Bank 1 (rear bank).
5. Install the air filter housing.
6. Install any remaining parts in reverse order.
7. Check for any additional leaks after installing the bolts.

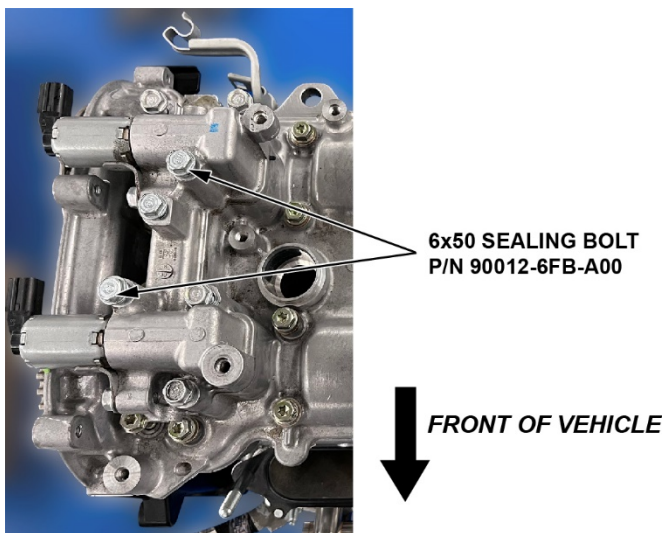

Repair B: Bank 1 Cylinder Head Replacement

1. Relieve the [fuel pressure](#).
2. Lift the vehicle.
3. Remove the front wheels, **127 N·m (94 lb-ft)**.
4. Remove the [engine undercover](#).
5. Partially remove the right-front fender liner.



FENDER LINER

6. Remove the three-way catalytic converter with the bracket.

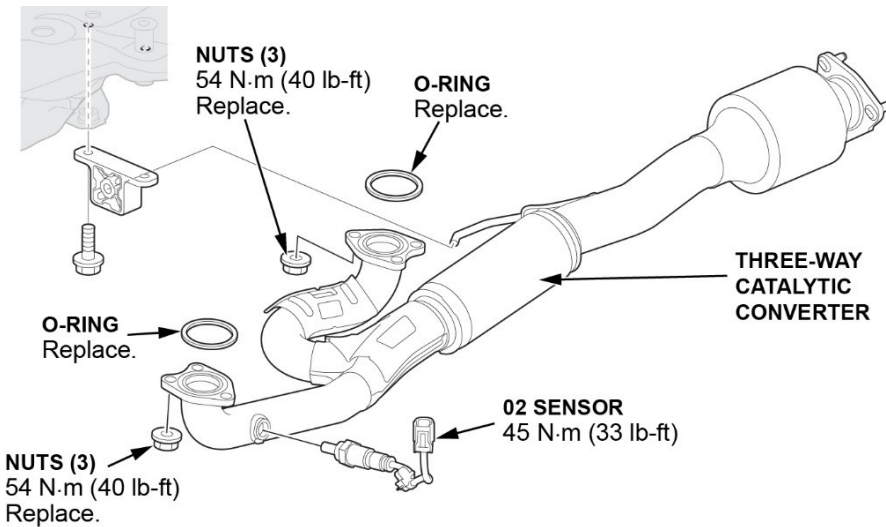

7. Drain the [engine coolant](#) from radiator.
8. Lower the vehicle.
9. Remove the front grille cover.

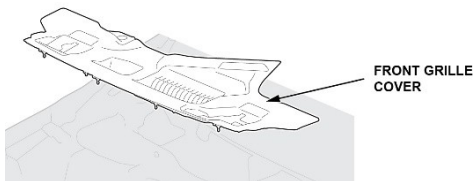

FRONT GRILLE COVER

10. Remove the [air cleaner housing and tubing](#).
11. Remove the [12-volt battery with tray](#).

12. Disconnect the Manifold Absolute Pressure sensor ([MAP](#)), and throttle body connectors.

NOTE: Remove the intake manifold **with the** throttle body attached.

[2023-2025 Pilot Fuel and Emissions Systems Component Location Index](#)

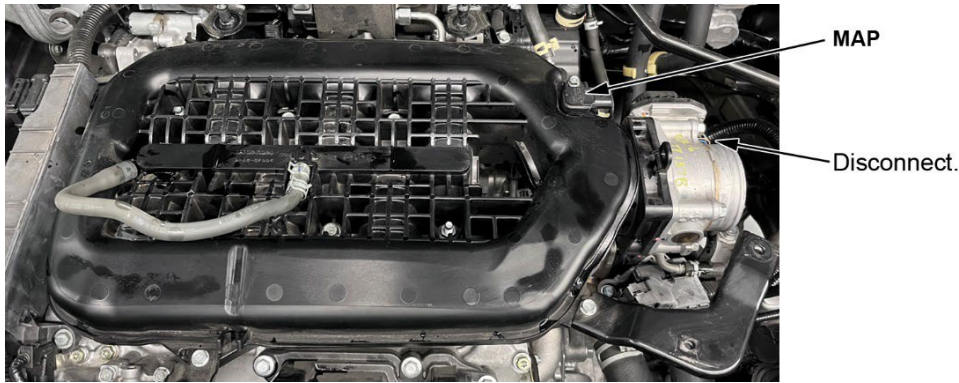

13. Remove the engine heat insulator, then disconnect the harness connectors at bank 1.

14. Disconnect the following: engine oil pressure switch, CMP sensor A and B, and high-pressure fuel pump.

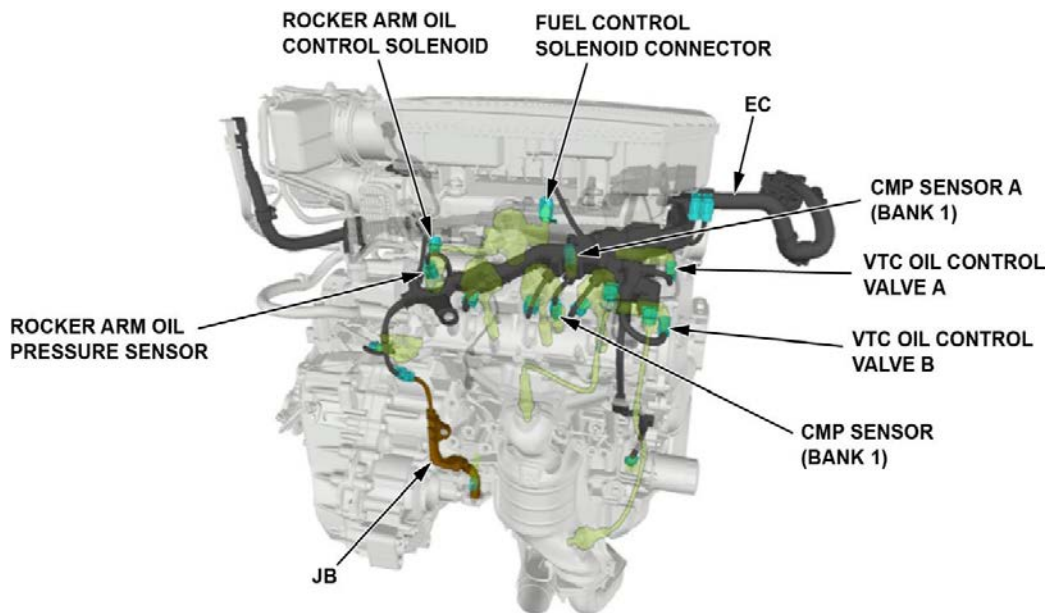

15. Disconnect the following: bank 1 VTC oil control valve A and B, bank 2 VTC oil control valve A and B, rocker arm oil control solenoid and pressure sensor.

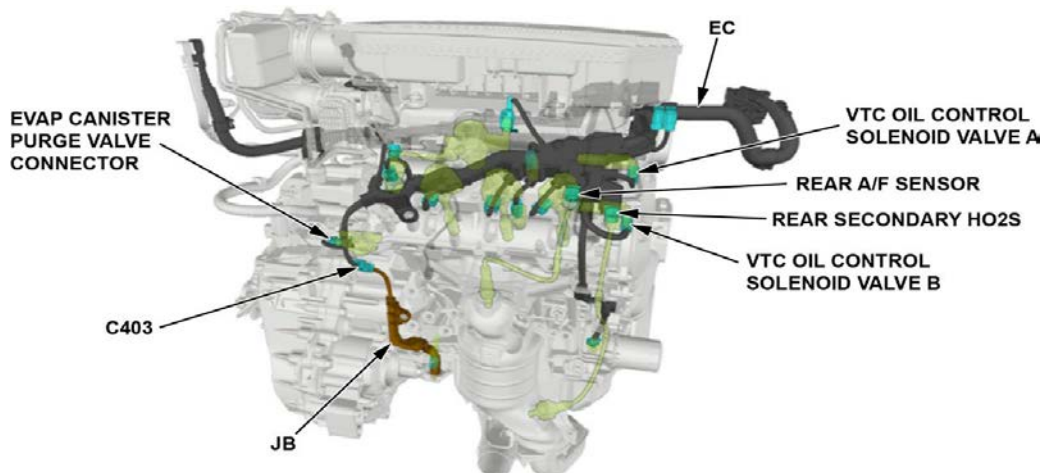

16. Disconnect the following: C407 and fuel rail pressure sensor.

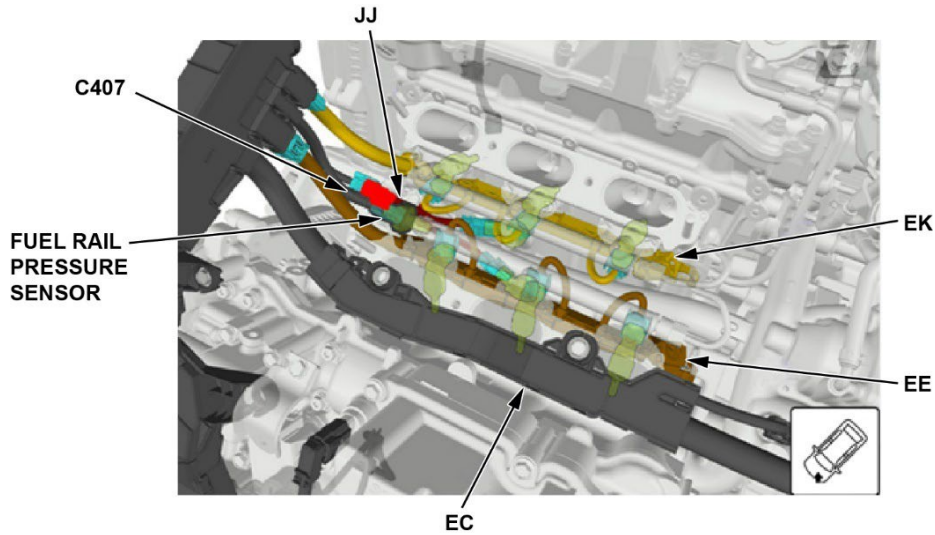

17. Disconnect the following: PCM E connector, C406, C405, and ECT sensor 1.

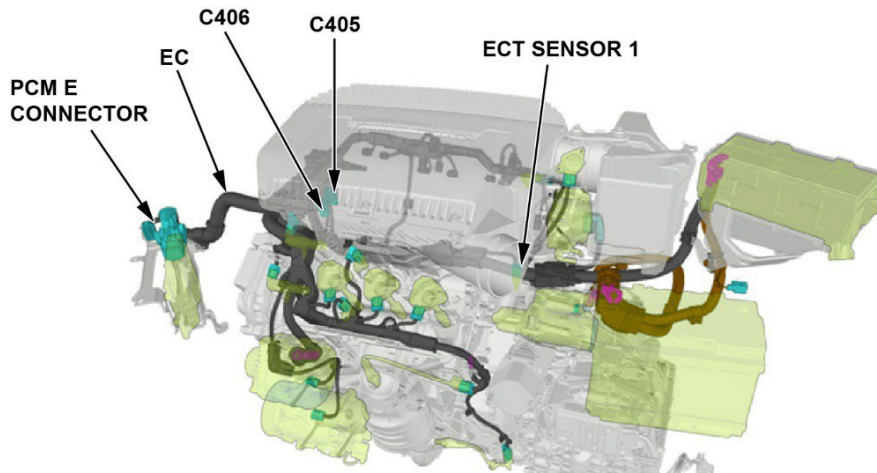

18. Once all the connectors are disconnected, lay the harness over Bank 2.

19. Remove the [intake manifold base](#).

20. Remove the cam end cover assembly, then remove the [PCV valve with bracket](#).

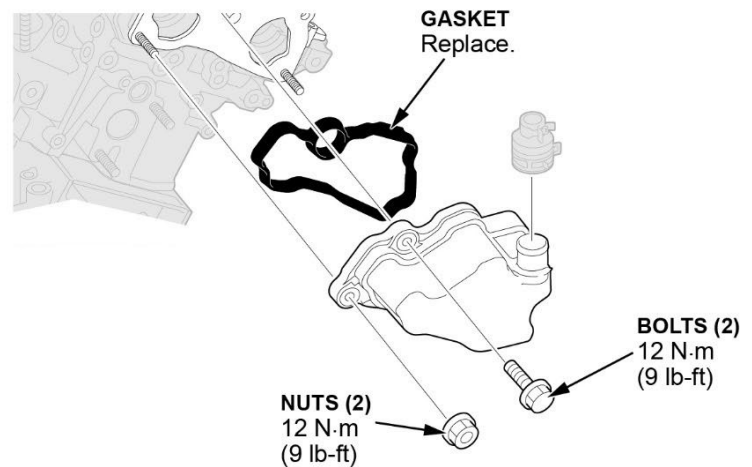

21. Remove the [fuel pump bracket](#).

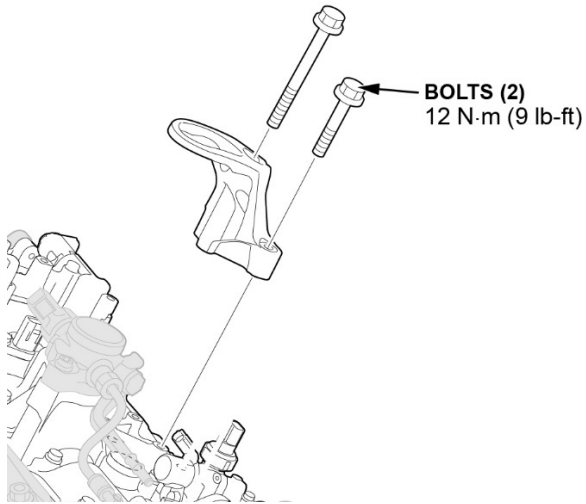

22. Bank 1 Ignition Coils and Spark Plugs remove.

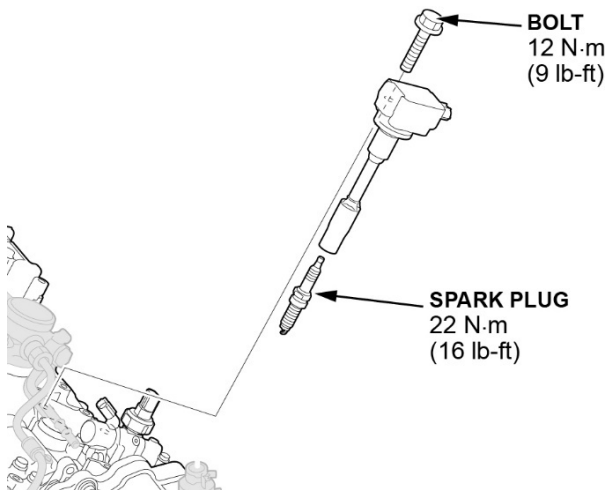

23. Remove the [skid block](#), then remove the [starter](#).

24. Remove coolant crossover pipe on the **transmission side only**.

NOTE: Leave the remaining coolant hoses still connected.

[2023-2025 Pilot Water Pump Area](#)

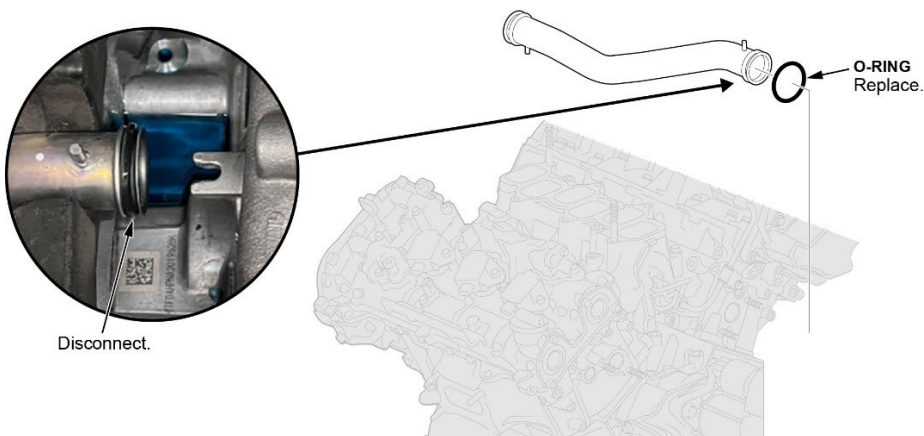

25. Remove the side engine mount and bracket as an assembly.



26. Remove the [fuel joint pipe](#).

[2023-2025 Pilot Intake Manifold Area](#)

27. Disconnect the [low-pressure fuel line](#) at high pressure fuel pump.

NOTE: Replace the fuel feed hose, fuel line, and/or quick-connect fitting if needed.

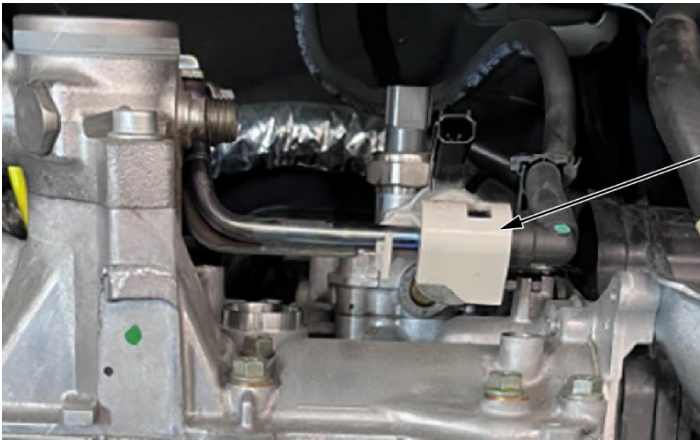

CONNECTOR
Disconnect.

28. Remove the [cam end cover assembly](#).

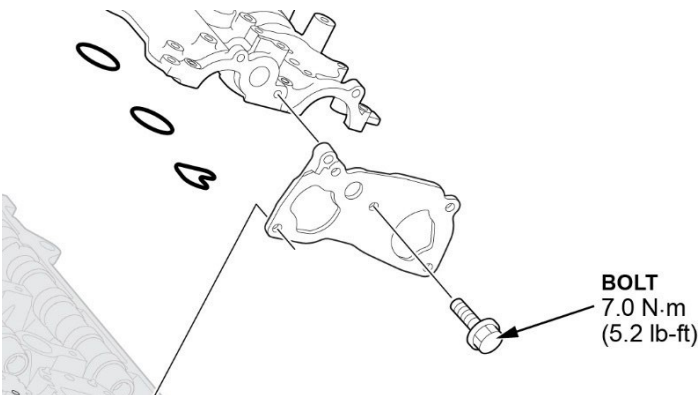

BOLT
7.0 N·m
(5.2 lb-ft)

29. Remove the [accessory drive belt](#).

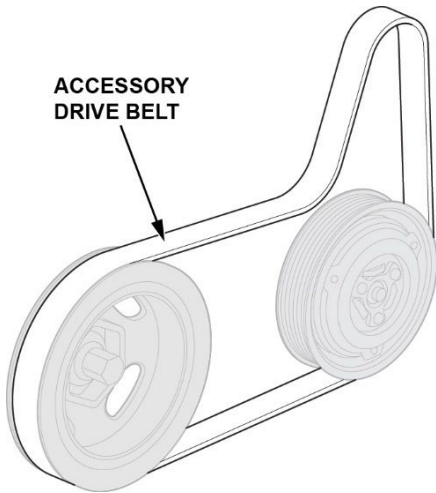

30. Remove the [crank pulley](#).
31. Remove the [timing belt mount cover, cam covers, and lower cover](#).
32. Re-install the crank bolt without the pulley. Set timing belt to TDC and marked VTC actuator teeth, belt, and cylinder head cover.

[Timing Belt Case/Timing Belt Area](#)

CRANK

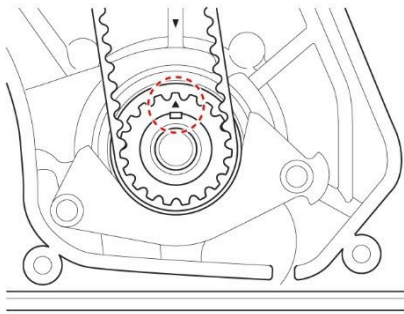

BANK 1 (REAR BANK)

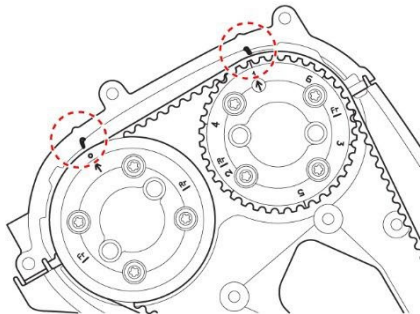

BANK 2 (FRONT BANK)

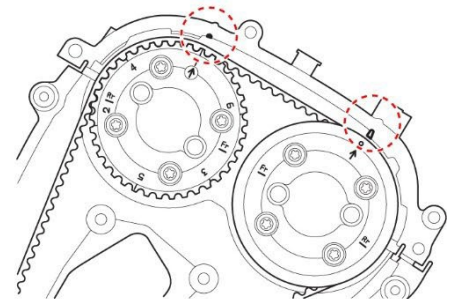

Set all to TDC.

33. Remove the VTC oil control valves, high pressure fuel pump with pump cam roller, rocker arm oil control housing, and catalyst heat shield.
34. Remove the 4 nuts at bank 1 catalyst and push catalyst towards firewall to clear cylinder head. Catalyst does not need to be removed from vehicle.

[Cylinder Head/Camshaft Area](#)

35. Remove VTC bolt covers.

[Timing Belt Case/Timing Belt Area](#)

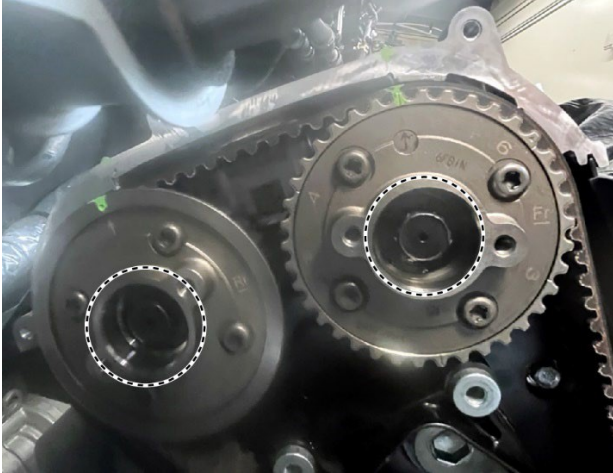

36. While holding cam at transmission side, use a 22 mm chrome socket and loosen the VTC cam gear bolts.
NOTE: Do not completely remove the VTC cam gear bolts.

[Timing Belt Case/Timing Belt Area](#)



37. Set cam holder tool (P/N 07AAB-6S9A100) to bank 1 actuators.

**CAM HOLDER TOOL
(P/N 07AAB-6S9A100)**

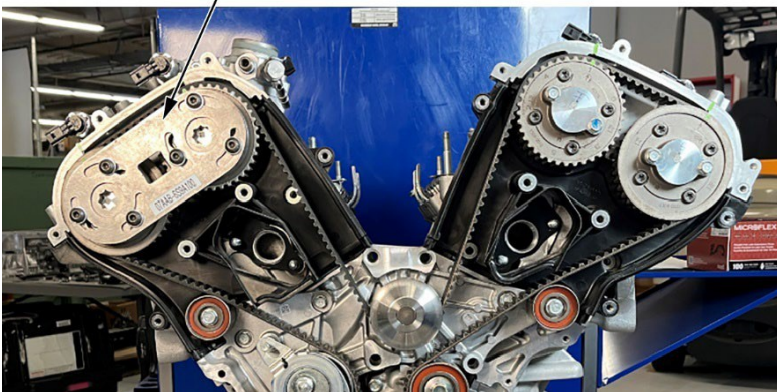

38. Rotate crank counterclockwise and lock timing belt tensioner in place with 3mm pin.

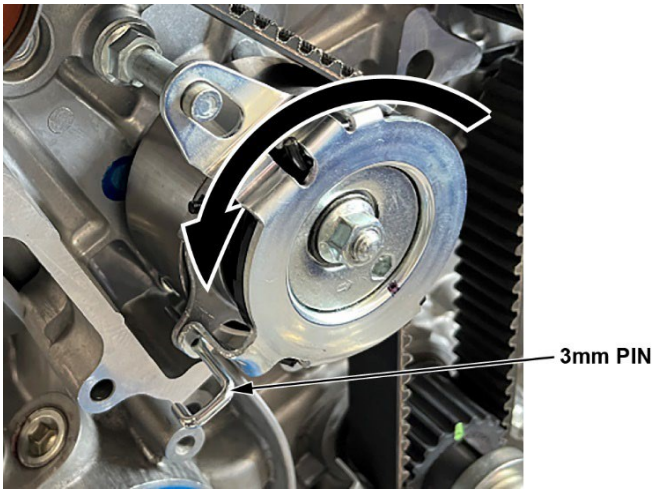

39. Remove the cam holder (Tool Number 07AAB-6S9A100).

40. Set cylinder 1 back to TDC. Confirm crank and bank 2 marks are also aligned to marks previously drawn.

Timing Belt Case/Timing Belt Area

CRANK

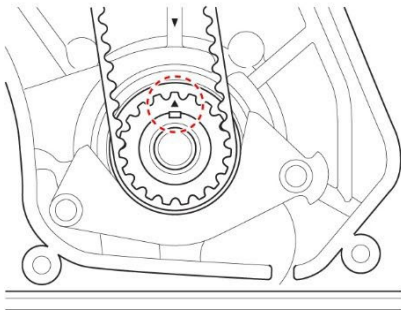

BANK 1 (REAR BANK)

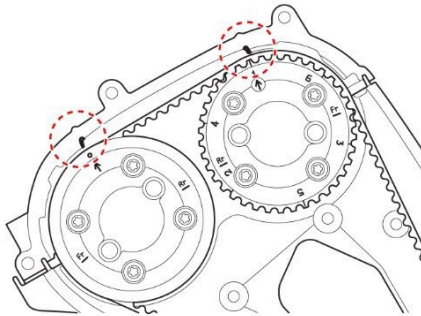

BANK 2 (FRONT BANK)

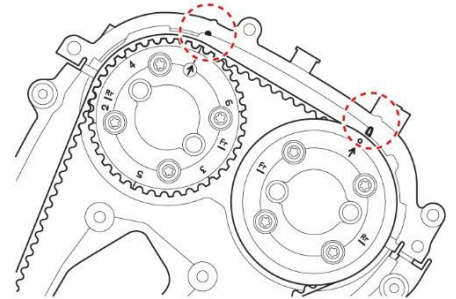

Set all to TDC.

41. Remove timing belt tensioner, then bank 1 idler pulley.

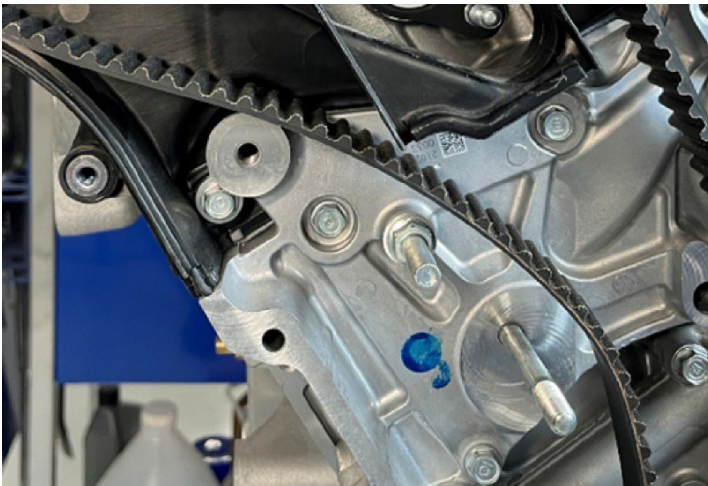

42. Lift and slide timing belt off bank 1 exhaust VTC actuator. Use 22mm socket and ratchet to adjust cam, as needed.

▶ **PLAY VIDEO**

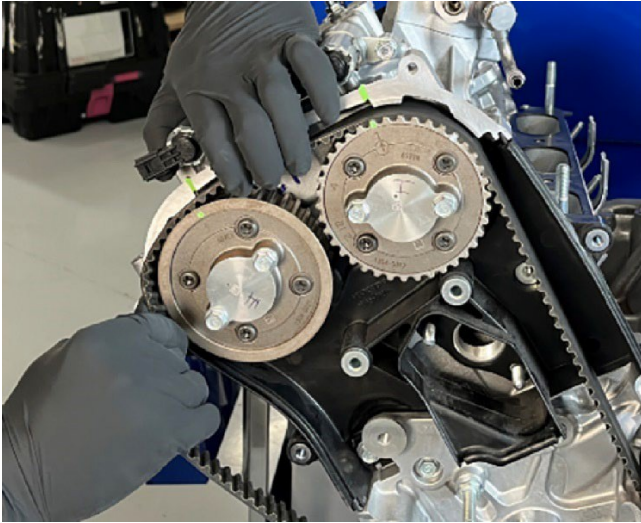

43. Lift and slide timing belt off bank 1 intake VTC actuator. Use a 22 mm socket and ratchet to adjust cam, as needed.



44. Remove the 17 mm bolt and slide off the VTC actuators for intake and exhaust. Tag and label each actuator. Do not mix intake and exhaust actuators.

NOTE: The intake actuator will have exposed gears.

EXHAUST



INTAKE



45. Remove cylinder head cover.

[Cylinder Head Cover Area](#)

46. Remove bank 1 cams from cylinder head.

NOTE: **Do not** mix intake and exhaust cams. Leave gear and cam together to avoid a mix-up.



Intake has high pressure fuel pump lobe.

47. Remove bank 1 cylinder head bolts.

[Cylinder Head Cover Area](#)

48. Lift bank 1 cylinder head to clear from engine block.



49. Remove the fuel injector sub harness from original cylinder head.



50. Remove the fuel rail from the original cylinder head.

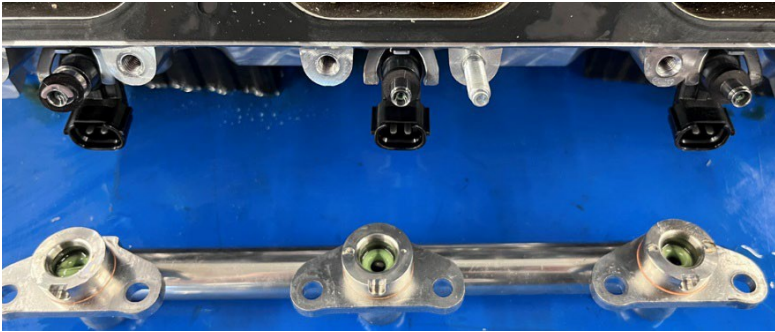

51. Remove fuel injectors from original cylinder head and replace injector seals and injector clips with special tool (P/N 007AG-5A0-A100).

52. Remove the [inner timing belt cover](#) from the original cylinder head.

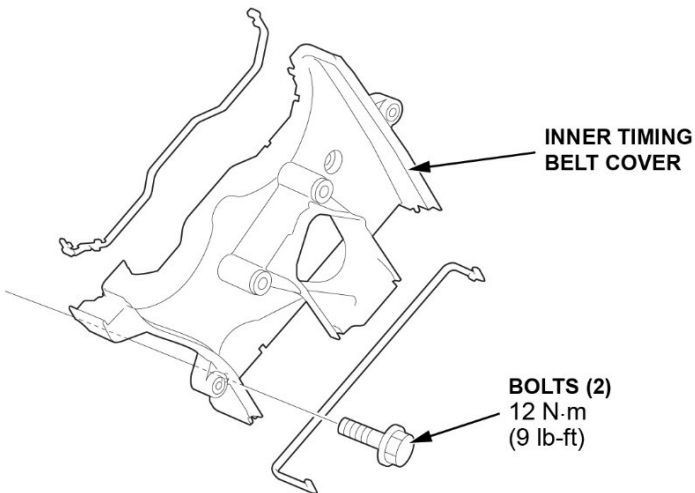

53. Remove the brackets for inline connectors and fuel line from original cylinder head.

54. Unpack new cylinder head. Head should come with package of seals and hardware.



55. Install injectors into new cylinder head and fuel rail.
56. Install the [valve lifters](#) into cylinder head.

✓ **CORRECT**

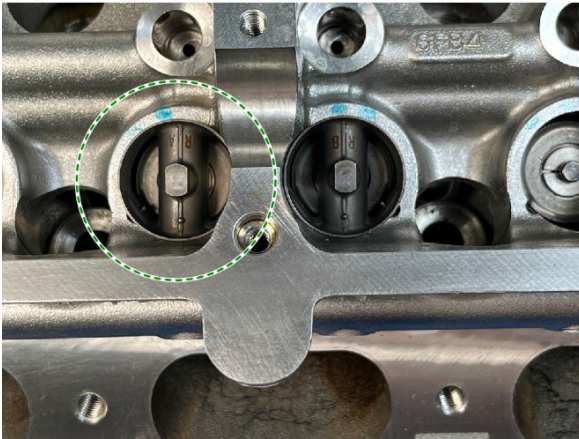

✗ **INCORRECT**

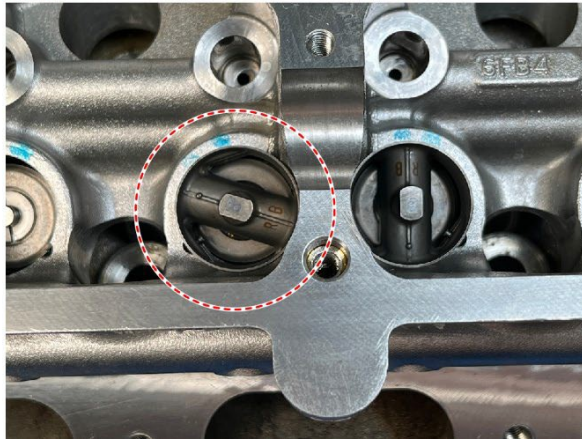

57. Install [hydraulic lash adjusters](#) and orifices into the cylinder head.

CORRECT

INCORRECT

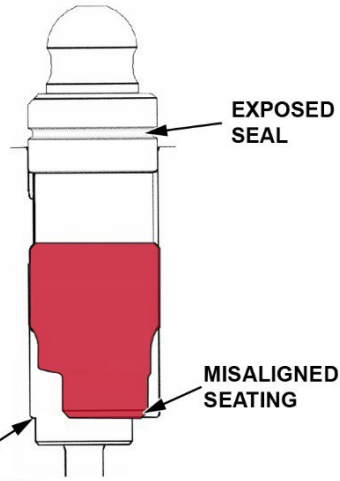
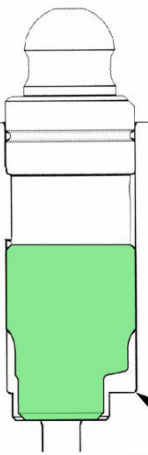

CYLINDER HEAD

58. Install the [rocker arms](#) into the cylinder head.

ROCKER ARMS

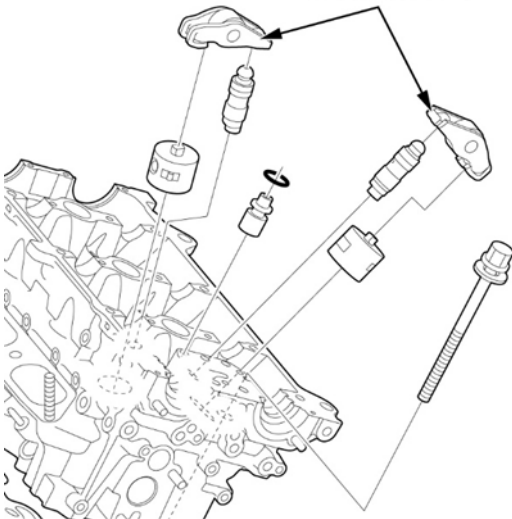

59. Confirm the cylinder [head dowel pins](#) are in place and lay the new head gasket onto the engine block.

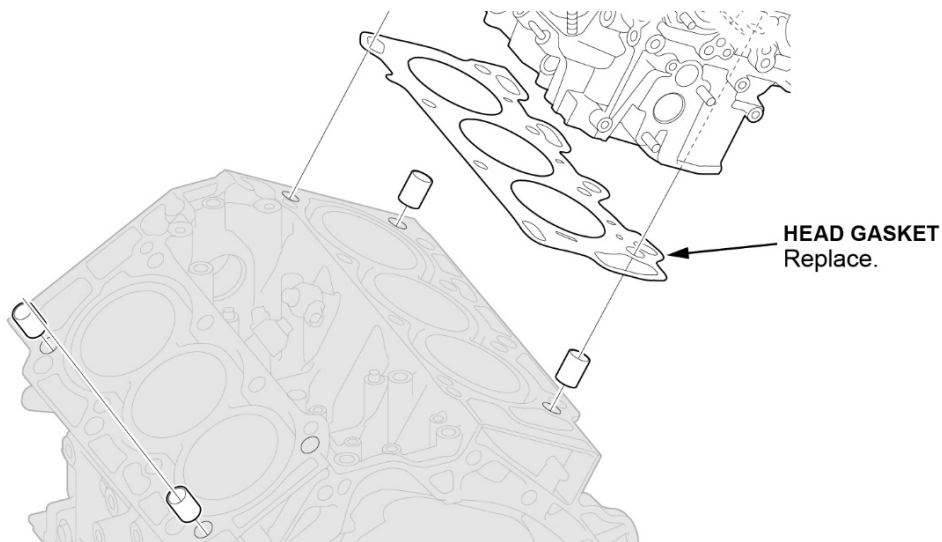

60. Set new cylinder head onto the engine block.

61. Torque the [cylinder head](#).

62. Remove the original cam oil seals and lay the [cams](#) into new cylinder head.

CAM OIL SEALS
Replace.

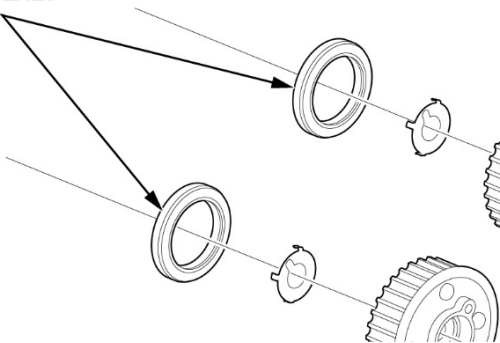

63. Apply sealant to cylinder head cover and install the cover.

64. Use special tool to install new cam oil seals (P/N 07AAD-6S9A100).

▶ PLAY VIDEO

65. Install VTC actuators and torque bolts to spec. Hold the cam with a 22 mm wrench while torquing bolts.

[Timing Belt Case/Timing Belt Area](#)

▶ PLAY VIDEO

66. Set timing belt onto the intake VTC actuator. Make sure marks are lined up. Adjust cam as needed to set belt.

67. Set timing belt onto the exhaust VTC actuator. Make sure marks are lined up. Adjust cam as needed to set belt.

68. Install bank 1 idler pulley.

69. Do the following:

▶ PLAY VIDEO

1. Pre-set tensioner adjustment with hex key. Install timing belt tensioner.
 2. Adjust bank 1 exhaust cam as needed to set belt over tensioner.
 3. Confirm all timing marks on timing belt, VTC gears, and cylinder cover are aligned.
 4. Pull pin from tensioner.
 5. Rotate crank pulley bolt clockwise until bank 1 intake VTC actuator indicator for cylinder 6 is lined up with cylinder head cover mark.
 6. Loosen nut at tensioner while holding HEX key at tensioner adjustment hole.
 7. Use HEX key to adjust tensioner until pointer is in notch.
 8. Torque tensioner lock nut.
 9. Rotate crank pulley bolt back to TDC cylinder 1. Confirm tensioner pointer is within notch and all VTC actuator gears and crank pulley are aligned to TDC.
70. Replace O-rings on VTC actuator bolt cover and install covers.

Timing Belt Case/Timing Belt Area

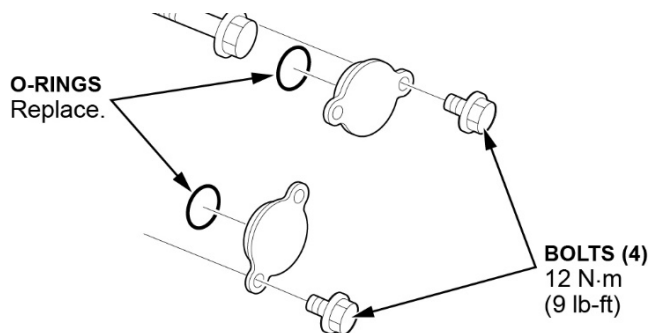

71. Transfer the [CMP sensors](#) from the original head cover to the new head cover.

72. Install the original OCV holder with **new sealing bolts**.

NOTE: New sealing bolts are **one time use** and cannot be reused if installed and removed.

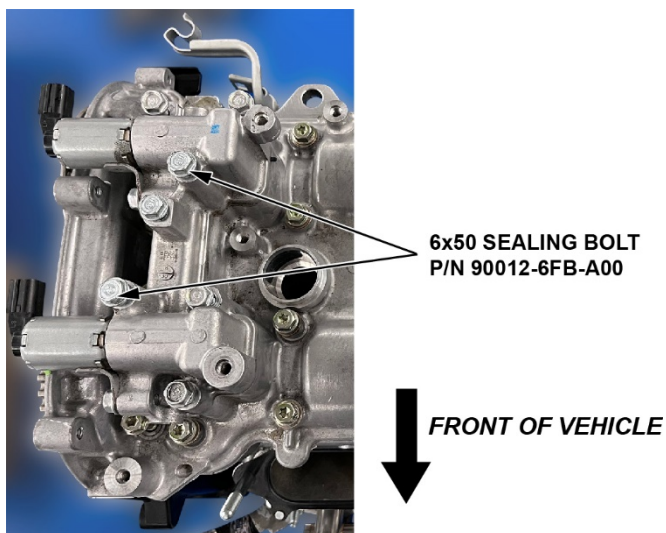

73. Install all remaining parts in the reverse order of removal.

74. Drain and refill the engine with new oil and install a new oil filter.

75. Add coolant, **7.7 L (2.03 US gal)**

76. Do the [idle speed inspection](#).

77. Check for **any** oil leaks.

Repair C: Replace the Secondary Oxygen Sensor

1. Replace the secondary oxygen sensor if needed.

