

Bulletin #: AS-54-25		<input type="checkbox"/> Take Note <input checked="" type="checkbox"/> Take Action	
<input type="checkbox"/> Retail Operator	<input type="checkbox"/> Sales Pre-Owned	<input checked="" type="checkbox"/> Business Manager	<input checked="" type="checkbox"/> Parts & Accessories
<input checked="" type="checkbox"/> General Manager	<input type="checkbox"/> Sales New Bike	<input checked="" type="checkbox"/> Service	<input type="checkbox"/> Administration
Name:		Phone Number:	
Title:		Source: Parts Logistics	
Email:			
Date: 7/18/2025		Supersedes: -	

# TEC773 ADJUST SHIFT CAM

## INSPECT OF ALL PARTS ON STOCK

### OVERVIEW

BMW AG has requested the inspection of all dealer stock of the part numbers listed below to ensure all parts in stock to ensure any parts in the unacceptable time range are returned.

Description	Part Number
Exhaust Camshaft Adjuster Switch Cam	13 63 5 A69 A91

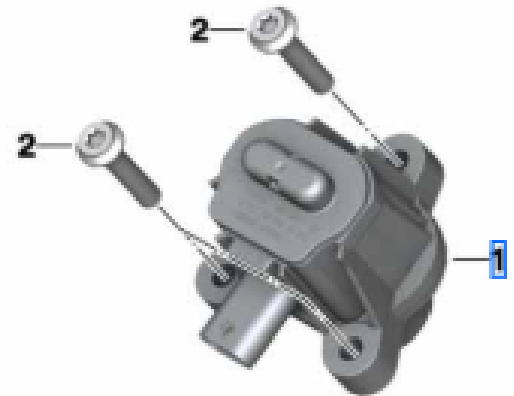

- The image to the right shows the parts as depicted in ETK. Please see under "MORE DETAILS" section for information to determine affected stock to be returned.
- Affected stock must not be sold or installed on any motorcycle.
- Affected is all stock of new spare parts shipped and delivered to date only.
- Please return all incorrect part(s) to your facing Regional Distribution Center (RDC). Submit for return using a YR26 damage claim with order reason BM2. A valid BMW delivery and delivery item number must be entered, and 'TEC773' must appear in the text of your TEC claim. For assistance locating the delivery number, please open an IDS ticket with Dealer Services in the Claims section directed to Returns/Claims/Quality.

### MORE DETAILS

### MAKE LIFE A RIDE



**BMW  
MOTORRAD**

- TEC773 is valid from July 18, 2025, through August 8, 2025. The deadline for filing a claim under TEC773 is August 8, 2025.
- All parts must be returned to your facing RDC no later than August 22, 2025.
- Please re-order as needed.

<p style="text-align: center;"><b>Affected Parts (NOT OK)</b></p> <p style="text-align: center;">All parts that are currently in stock.</p>	<p style="text-align: center;"><b>Non Affected Parts (OK)</b></p> <p style="text-align: center;">All parts that are ordered from 7/18/2025 onward.</p>
---------------------------------------------------------------------------------------------------------------------------------------------	--------------------------------------------------------------------------------------------------------------------------------------------------------

## MORE QUESTIONS?

Aftersales Business Development Manager		
Material Planning and Parts Logistics Analyst		

**MAKE LIFE A RIDE**