

Circular Letter

FROM: Maserati TSO

TO: Maserati Network

Maserati

PERSONAL SERVICE LAB

MASTERS OF CARE

Introduction to Maserati Grecale



IMPORTANT NOTICE This bulletin supersedes MAS004618 MCL 25-10 released on March 4, 2025. It contains updated information, please ensure all previous versions are discarded.

DATE: July 25, 2025

The new Parts & Service mission aims to ensure a unique customer experience. A few important guidelines for the technical management of the New Maserati Grecale are set out in this letter. Maserati Grecale represents the right balance between versatility, elegance, performance, and innovation, guaranteeing services, comfort, and safety at the same time; features that combine with off-road capabilities and steadfast driving pleasure.

The new MY23 Grecale SUV, developed at Maserati Innovation Lab in Modena, is a range within the range, the most complete and innovative ever in the House of the Trident. The range of available engines varies from the traditional combustion to the hybrid engine and includes three launch versions: GT, powered by a 4-cylinder Hybrid capable of developing 300 HP, Modena with a 330 HP 4-cylinder Hybrid engine, and the powerful Trofeo, equipped with a performing 530 HP 3.0L V6 engine, derived from the Neptune engine which equips MC20.

Topics covered in this Bulletin:

- Taking charge of the vehicle and periodic checks.
- Indications of best practices and technical notes for the Grecale Service.
- Pre-Delivery inspection checklist.
- Activation of the technical team.
- Unveiling tech-doc/diagnosis and special tools.

Please read and review this bulletin first before starting the procedure.

Contact your Regional AfterSales Manager (RAM) or the Technical Support Helpdesk if you have any questions.

Contents

1	Vehicle maintenance and periodic battery checks	2
1.1	12V Battery Inspection at PDI.....	2
1.2	Check/restore 12V battery State Of Charge (SOC).....	2
2	Best practices in the workshop for Grecale service	3
2.1	Lifting the vehicle.....	3
2.2	Door opening.....	4
2.3	12 V battery access.....	5
2.4	Disconnect the 12V battery negative cable.....	5
2.5	Emergency start - dead battery.....	5
2.6	Transmission unblocking.....	6
3	Pre-Delivery Inspection Checklist	7
3.1	Procedures performed with MEVO.....	7
4	Activation of the Technical Team	8
5	Technical Documents, Electronic Diagnosis, and Special tools	8
5.1	Contained visibility.....	8
5.2	New GUI MDEVO for Grecale.....	8
5.2.1	Vehicle view.....	9
5.2.2	PROXI unaligned between vehicle and server.....	10
5.3	Special tools.....	11

1 Vehicle maintenance and periodic battery checks

The specifics on the maintenance of the vehicles in stock are reported as usual in the dedicated circular letter, which undergoes periodic updates (**See MAS004488 MCL 25-15 MGNT And MAINT Of Instock Vehicles or newer for details.**) In particular, the new Maserati GranTurismo features require more restrictive 12V battery charge status control logistics than other models in the Maserati family. The checks involve:

- Performing a Battery test using the E-XTEQ MAXIMUS at PDI.
- Performing a Battery test using the E-XTEQ MAXIMUS during the entire storage period.

1.1 12V Battery Inspection at PDI

Performing a Battery test following the procedures outlined in bulletin “MAS004655 MCL 25-21 Battery Policy for “E-XTEQ” Maximus charger tester (Or Newer)”.

1.2 Check/ restore 12V battery State Of Charge (SOC)

Perform a Battery test using the E-XTEQ MAXIMUS during the entire storage period at Intervals outlined in “MAS004488 MCL 25-15 MGNT And MAINT Of Instock Vehicles”.

2 Best practices in the workshop for Grecale service

The following chapter includes a list of best practices and technical notes for Maserati Grecale Service; this vehicle's features require precautions that may otherwise not be noticed or highlighted. While the car is undergoing normal operations in the workshop.

2.1 Lifting the vehicle

The position of the lifting points is indicated by an inverted triangle stamped on the edge of the body; there are also vehicle side pads for interfacing the axle positioning.

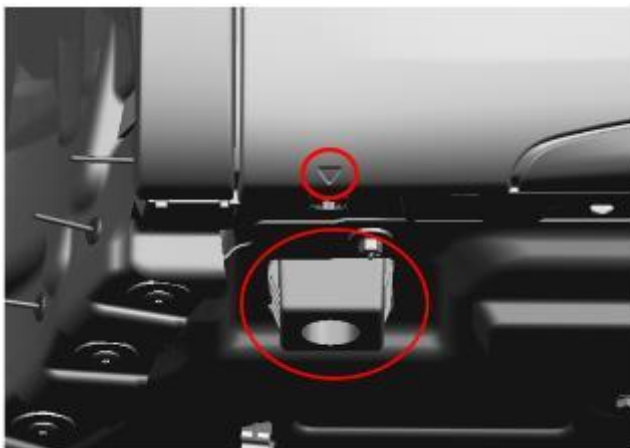

Front pad



Rear pad

Be careful about the axle geometry to prevent damaging the vehicle during the lifting operation. We recommend removing all possible loads from the vehicle (passengers, luggage, spare tire, etc.) to increase the distance from the ground (in case there are no air springs).

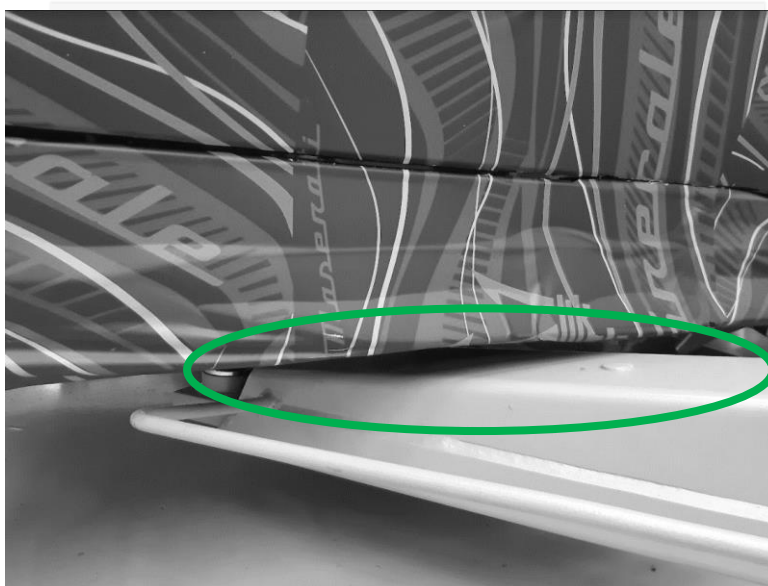

We recommend using lift plates with a diameter no greater than 125mm for the front axle and centering the plate on the lifting dowel as well as possible to prevent contact with the car's floor trim.

2.2 Door Opening

The following diagram summarizes the instructions in the onboard documentation concerning the door opening controls:

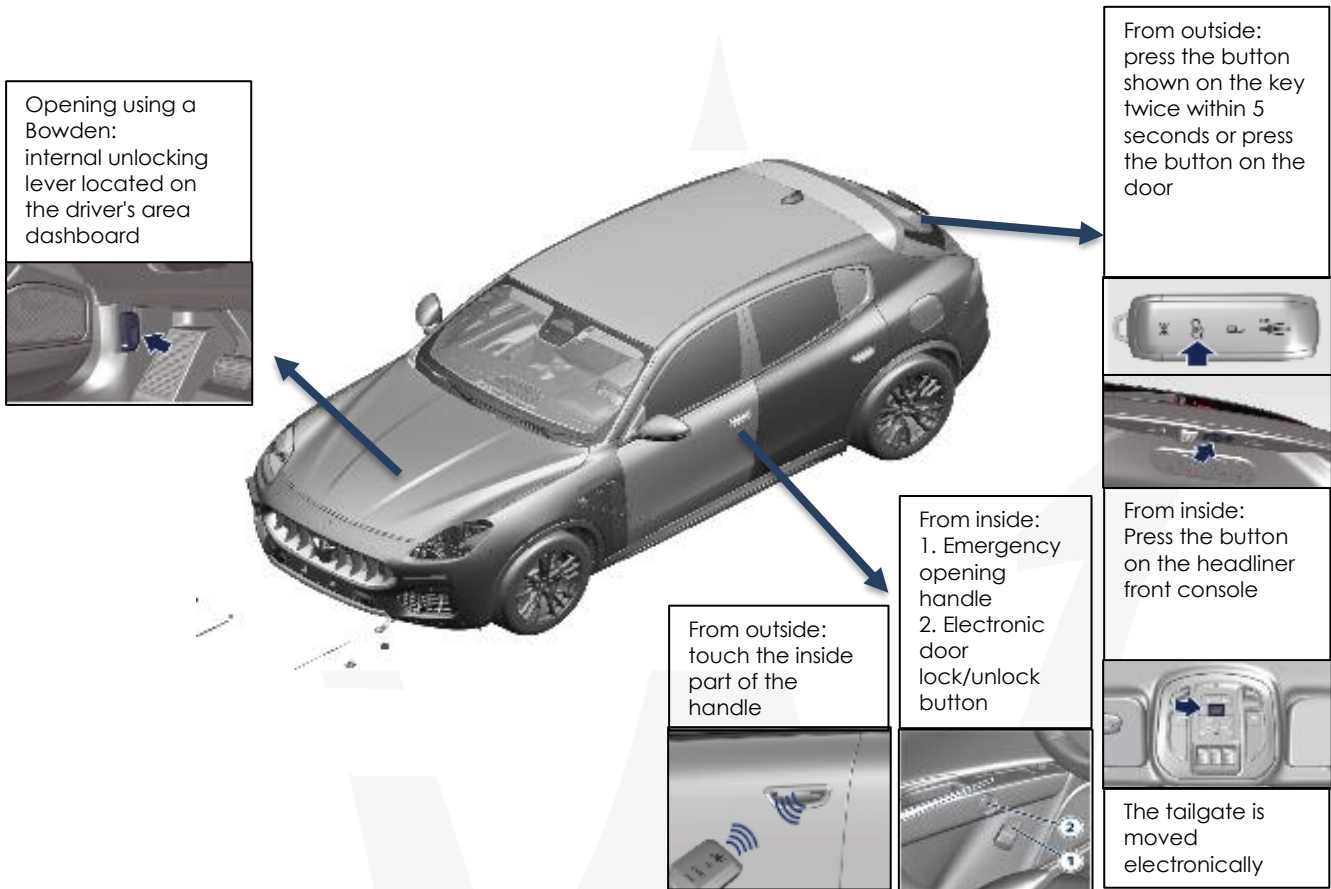

If the 12 V battery is discharged and the electric locks cannot be powered, the key fob has an emergency mechanical key that can unlock the driver's side door with a lock corresponding to the handle itself, as shown in the figure below:



2.3 12 V Battery access

The battery is positioned on the inside of the boot lid in the center. You need to lift the boot lid bottom panel and remove the battery cover to access the battery.

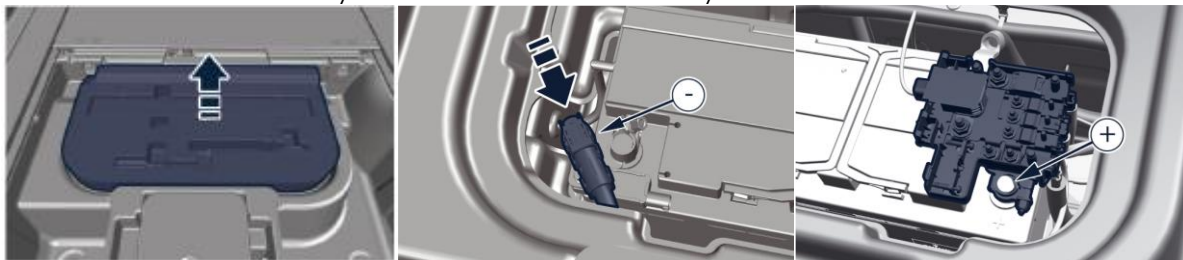

2.4 Disconnect the 12V Battery negative cable.

If you need to disconnect the 12V battery negative pole (for example, due to long vehicle inactivity), you can access it by removing the bottom cover of the rear trunk:

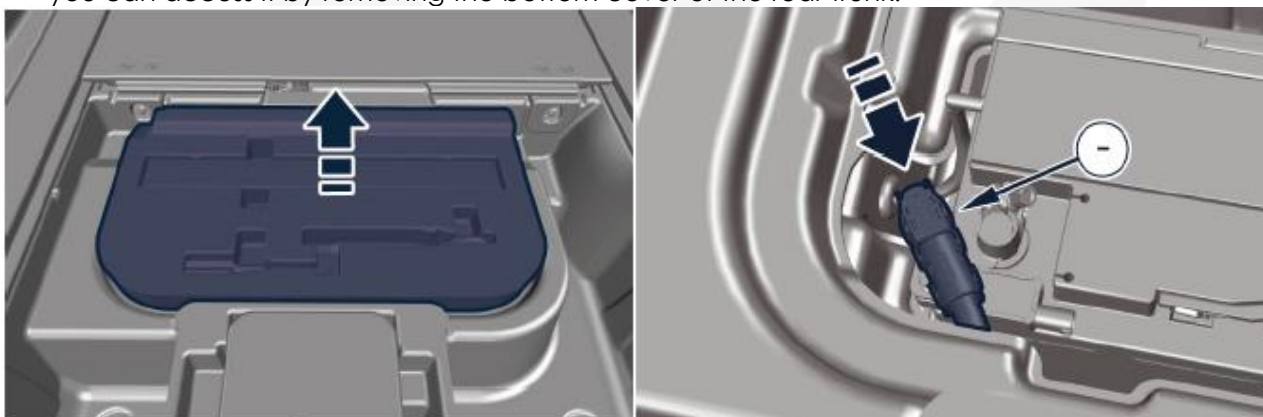

2.5 Emergency start - dead Battery

If an emergency start is needed for a dead battery, the remote poles located in the engine compartment can be used, as indicated in the following figures:

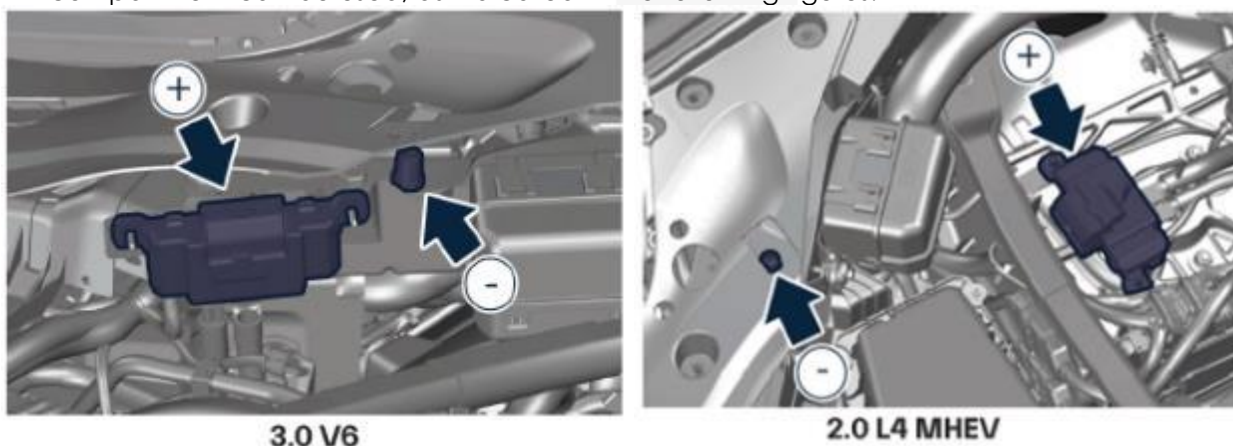

2.6 Transmission Park Release

If you need to move the car with the engine off, the "Car Wash" mode can be activated. As shown below:

- The car must be on a level surface, not moving
- Put the transmission in N (Neutral) by using the control on the dashboard

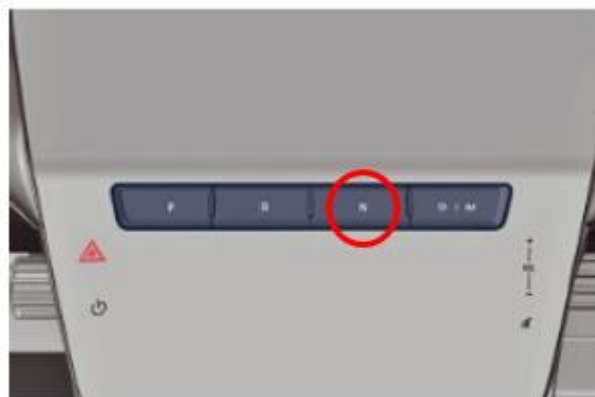

- Turn the engine off by pressing the START/STOP button.

The driver's door must be shut during these steps. This condition must be maintained for about 15 minutes, after which the transmission moves to P (Park).

If this solution is not possible or if there are other transmission problems, the transmission can be released manually as follows:

- Lift the car just enough to be able to reach the inside central area
- Identify the automatic transmission and the release actuator lever

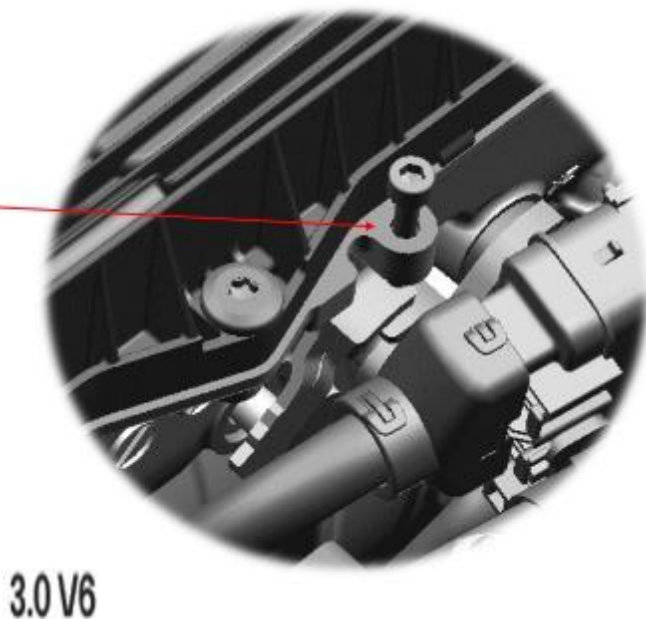
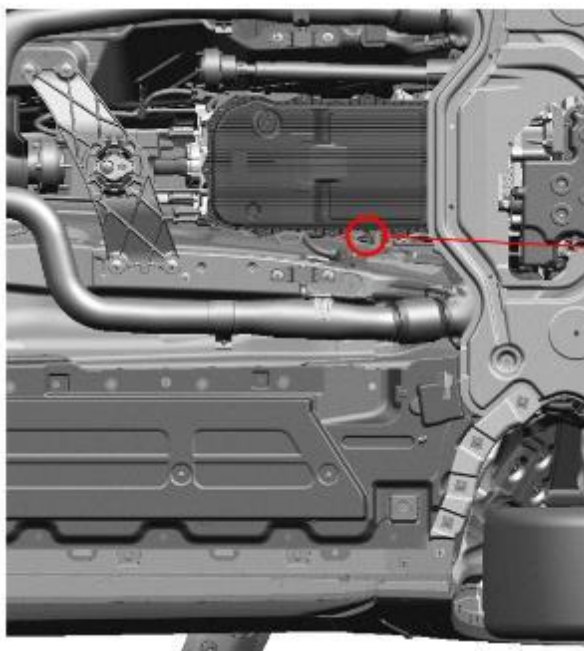

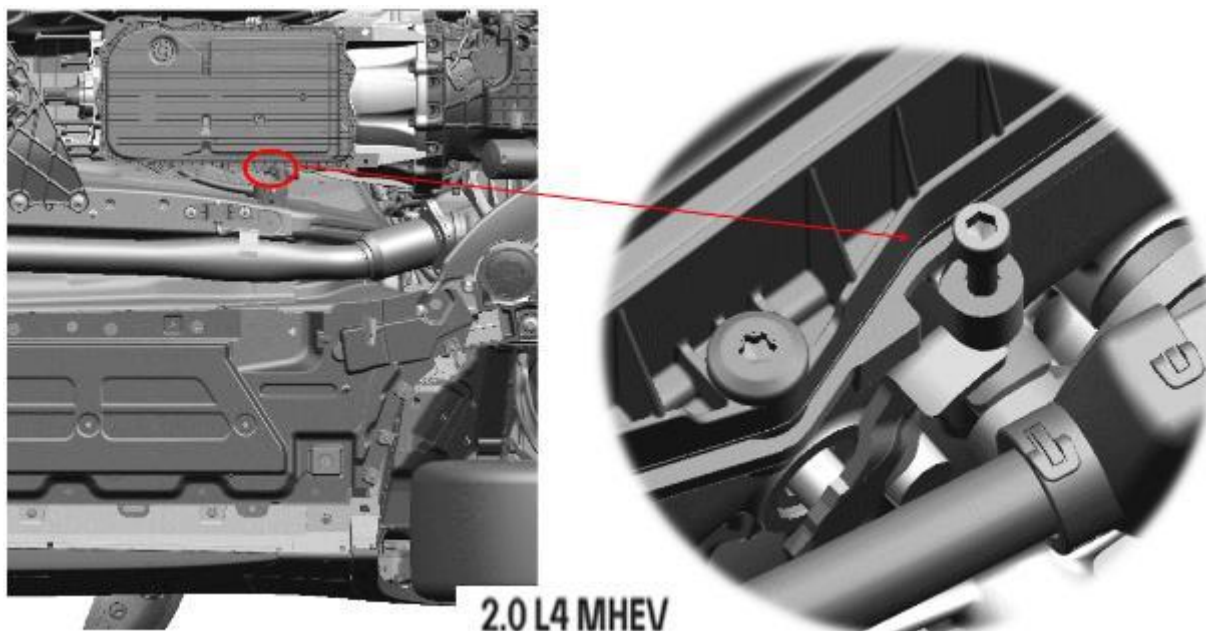

2.0 L4 MHEV

Warning: the transmission unblock lever actuator is not in the car: you need to use an M6 screw at least 32.4 mm long.

3 Pre-Delivery Inspection Checklist

To support you in delivering the new Maserati Grecale, we have developed a specific Checklist, adding new checks to test the new features and ensure that the customer can drive the car with maximum satisfaction. In addition, some policies regarding the control of the charge status of the 12V battery have been modified. The Checklists are attached to this communication.

The Checklist will guide you through the various stages of vehicle inspection and preparation. Each Checklist includes a set of actions and procedures to be carried out on each car during the PDI.

At the end of each car preparation, we ask you to keep a copy of the Checklist, signed by the operator who has performed the checks, to support process traceability that could be helpful to improve the quality of the service offered, where necessary. Maserati could also request a copy of the same during the contractual warranty period for statistical purposes for its product improvement processes.

3.1 Procedure performed with the MEVO

Setting the vehicle in "Customer Mode" to be performed at the POI stage is set out in Circular Letter **MAS003184** (Or newer).

4 Activation of the Technical Team

A cross-functional Technical Team has been established, comprising individuals from Product Support, Engineering, Quality, Spare Parts, Customer Care, and RAM departments. In addition to introducing innovative technical content, the team is dedicated to offering comprehensive support for accurate diagnosis and resolution during initial interventions within the network. Furthermore, they aim to conduct swift and effective investigations into all reported anomalies. **For details on submitting BOLs to report anomalies, please consult the latest "Blue On Line Policy Update" Bulletin.**

To monitor the correct progress of the vehicle repair on new models and ensure corrective action for anomalies found during PDI. Maximum care is required in manually setting the Service Entry status. Please also remember that the Service Entry status is automatically set up in "Awaiting Spare Parts" when the parts to be replaced are related to interventions covered by the contractual warranty and ordered in VOR mode. With a view to product improvement and to allow Maserati to improve the diagnostic effectiveness, you will also need to analyze promptly the defective components replaced. For this purpose, applying the following indications for the entire duration of the Technical Team is required:

1. Warranty claims must be entered within two working days of closing the Service Entry.
2. Components replaced and requested for urgent return must be sent within two working days of receiving the request. Please refer to the Maserati warrant urgent parts return bulletin in Modis for details.

5 Technical Documents, Electronic Diagnosis, and Special Tools

5.1 Technical Information

TechDocs has been updated to include technical documentation for both Grecale Hybrids (GT and Modena) and the Grecale V6 (Trofeo):

- Parts catalog
- Labor Times
- Workshop Manual
- Wiring Diagrams
- Diagnostic Help

5.2 New GUI MDEVO for Grecale

With the new Maserati Grecale launch, MDEVO introduces a new GUI (Graphical User Interface) specifically for the new generation of vehicles.

5.2.1 Vehicle view

The new Vehicle View for Maserati Grecale (M182) appears as in the figure below:



The new view allows you to identify all the vehicle's internal CAN and CAN-FD networks. Five sections are inside the Vehicle View:

1. Topological view: a view of all the ECU, CAN, and CAN-FD connections
2. Zoom function: to enlarge, reduce, and restore the topological view
3. ECU list: lets you order the ECU according to the different filters (alphabetical, upgrades, errors, and nodes)
4. ECU groupings: This allows you to highlight the selected ECU functional unit (transmission, engine, ADAS, etc.)
5. ECU research: the control unit is highlighted in the topological view while the others are darkened.

By selecting the ECU, you can access the control unit's standard section to follow diagnostic operations (basic diagnosis, active, procedures, programming, reading, and deleting DTC).

5.2.2 PROXI unaligned between the vehicle and server

The new GUI shows all the control units available for the Maserati Grecale, making those. Not present in the identified vehicle configuration, transparent, and unselectable.



If the PROXI (Vehicle Configuration) readings on BCM are different from the ones on the server, all ECUs will be displayed as selectable.

For alternative control units, such as ECM V6 (ICE) and ECM L4 (MHEV), selecting the functional control unit (ECM) will open a pop-up that will allow you to choose the correct one, thus accessing the standard section to perform the diagnostic operations.

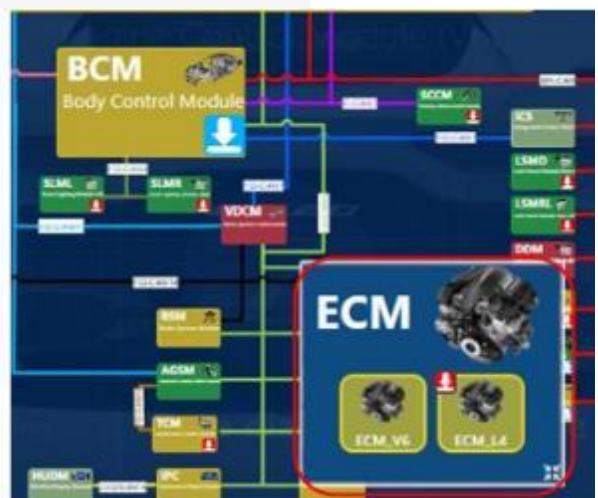
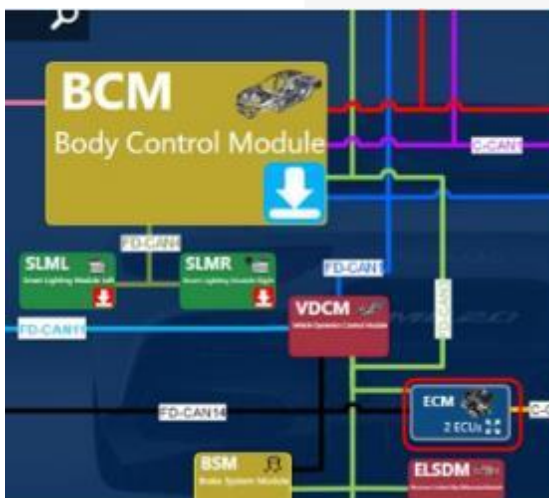

5.3 Special tools

Maserati has created a set of special tools specifically for the new Grecale to ensure the Highest levels of quality in driving assistance and safety. Such mandatory tools will be supplied. Automatically and will also be present on the ModisCS+ Special Tool Catalogue.

The tools are listed below in the table, along with a brief technical description:

P/N	Name	Engine
900030610	Engine-transmission removal tool upgrade	Hybrid/ICE
900030611	Rear axle removal tool upgrade	Hybrid/ICE
900030612	Tool for transmission oil filler cap	Hybrid
900030613	Assembly tool for brake pad springs	Hybrid
900030614	L4 engine lifting brackets	Hybrid
900030616	V6 engine lifting brackets	ICE
900084528	Engine mount on TRANSMISSION SIDE	ICE
900030617	Engine mount on SERVICES SIDE	ICE
900030807	M182 Car Bench Template Kit	Hybrid/ICE
900030806	M182 Global Jig Template Kit	Hybrid/ICE
900030739	Flex plate locking tool V6	ICE
900030737	Belt tensioner	Hybrid
900084527	Upper oxygen sensor tightener	ICE
900030741	Chain tensioner pin	Hybrid

How to use each tool is detailed in the relevant repair procedure via TechDocs.

- **Engine-transmission towing tool upgrade** (900030610): This front towing tool upgrade will be used for assembling and disassembling the engine and transmission for both engine versions.
- **Rear axle towing tool upgrade** (900030611): This rear axle towing tool upgrade will be used for assembling and disassembling the rear suspension chassis for both engine versions.
- **Transmission oil filler cap tool** (900030612): This tool will be used to unscrew and re-tighten the Hybrid variant transmission oil cap.
- **Brake pad spring assembly tool** (900030614): This tool will be used to assemble and correctly position the Hybrid variant front brake pad spring.
- **L4 engine lifting brackets** (900030614): This tool will allow you to lift the 4-cylinder engine, holding it in suspension with suitable equipment.
- **V6 engine lifting brackets** (900030616): This tool will allow you to lift the 6-cylinder engine, holding it in suspension with suitable equipment.
- **TRANSMISSION SIDE Engine Mount** (900084528): This tool will allow you to bench install the 6-cylinder engine from the transmission side.
- **SERVICE SIDE engine support** (900030617): This tool will allow you to bench install the 6-cylinder engine on the service side.
- **M182 Car Bench Template Kit** (900030807): This kit, to be used with the templates already in the workshops' possession, will allow you to check and repair the vehicle's bodywork correctly for both engine versions.
- **M182 Global Jig Template Kit** (900030806): This kit, to be used with the templates already in the workshops' possession, will allow you to check and repair the vehicle's bodywork correctly for both engine versions.
- **V6 Flex Plate Lock** (900030739): This tool will allow you to lock the V6 engine flex plate.
- **Belt tensioner** (900030737): This tool will allow you to replace the Hybrid engine service belt.
- **Upper oxygen sensor tightener** (900084527): This tool will allow you to tighten the V6 engine oxygen sensors to the correct torque.
- **Belt Tensioner pins** (900030741): This tool will allow you to lock the Hybrid engine chain tensioners correctly.