

Circular Letter

FROM: Maserati TSO

TO: Maserati Network



Maserati

PERSONAL SERVICE LAB

MASTERS OF CARE

Introduction to the new Maserati GranTurismo & GranCabrio



IMPORTANT NOTICE This bulletin supersedes MAS003827_A MCL 24-34 released on June 27, 2024. It contains updated information, please ensure all previous versions are discarded.

DATE: JULY 25, 2025

We are pleased to inform you that we have published the updated version of the "Introduction to the New Maserati GranTurismo" on ModisCS+. This update supersedes the previous circular letter MAS003504 and includes additional content related to the new GranCabrio.

Our new Parts & Service mission is dedicated to ensuring a unique experience for our customers. This letter outlines important guidelines for the technical management of the new Maserati GranTurismo and GranCabrio.

Developed at the Maserati Innovation Lab and manufactured at the Mirafiori Plant in Turin, the GranTurismo and GranCabrio are 100% made in Italy and embody Maserati's "Italian luxury performance" concept. Both models feature the revolutionary Neptune V6 engine in two variants: the Modena version with a 3.0-liter V6 Neptune Twin Turbo delivering 490 hp, and the high-performance Trofeo version based on the same engine, achieving a peak output of 550 hp.

This document includes in detail:

- Vehicle maintenance and periodic battery checks.
- Indications of best practices and technical notes for Service.
- Pre-Delivery inspection checklist.
- Activation of the technical team.
- Unveiling tech-doc/diagnosis and special tools.

Please read and review this bulletin first before starting the procedure.

Contact your Regional AfterSales Manager (RAM) or the Technical Support Helpdesk if you have any questions.

Contents

1	Vehicle maintenance and periodic battery checks.....	2
1.1	12V Battery Inspection at PDI.....	2
1.2	Check/ restore 12V battery SOC.....	2
2	Best practices in the workshop for service.....	3
2.1	Lifting the vehicle.....	3
2.2	Door opening.....	4
2.3	12V battery location.....	5
2.4	Disconnect the 12V battery negative cable.....	6
2.5	Emergency start - dead battery.....	6
2.6	Transmission Park Release.....	6
3	Pre-Delivery inspection checklist.....	7
4	Activation of the technical team.....	7
5	Technical Documents and Special Tools.....	8
5.1	Technical Information.....	8
5.2	Special Tools.....	8

1 Vehicle maintenance and periodic battery checks

The specifics on the maintenance of the vehicles in stock are reported as usual in the dedicated circular letter, which undergoes periodic updates (**MAS003825 and its subsequent revisions**). In particular, the new Maserati GranTurismo features require more restrictive 12V battery charge status control logistics than other models in the Maserati family. The checks involve:

- Performing a Battery test using the E-XTEQ MAXIMUS at PDI.
- Performing a Battery test using the E-XTEQ MAXIMUS during the entire storage period.

1.1 12V Battery Inspection at PDI

Performing a Battery test following the procedures outlined in bulletin “MAS004655 MCL 25-21 Battery Policy for “E-XTEQ” Maximus charger tester (Or Newer)

1.2 Check/ restore 12V battery State Of Charge (SOC)

Performing a Battery test using the E-XTEQ MAXIMUS during the entire storage period at intervals outlined in “MAS003825 MCL 24-13 MGNT And Maintenance Of Instock Maserati Vehicles”.

Vehicle Transport Delivery

After vehicle transport delivery from the port, and after removing the bodywork wrapguard, it is necessary to check the absence of textile residues and dirt on the canvas soft top. To remove residues from the soft top, you can use an adhesive roller. Do not wash the GranCabrio unless you have first checked that the soft top is clean and intact (the presence of foreign bodies can cause damage to the soft top).

2 Best practices in the workshop for service

The following chapter includes a list of best practices and technical notes for Maserati GranTurismo Service; this vehicle's features require precautions that may otherwise not be noticed or highlighted while the car is undergoing normal operations in the workshop.

2.1 Lifting the vehicle

The position of the lifting points is indicated by an inverted triangle stamped on the edge of the body. There are also vehicle side pads for interfacing the axle positioning.

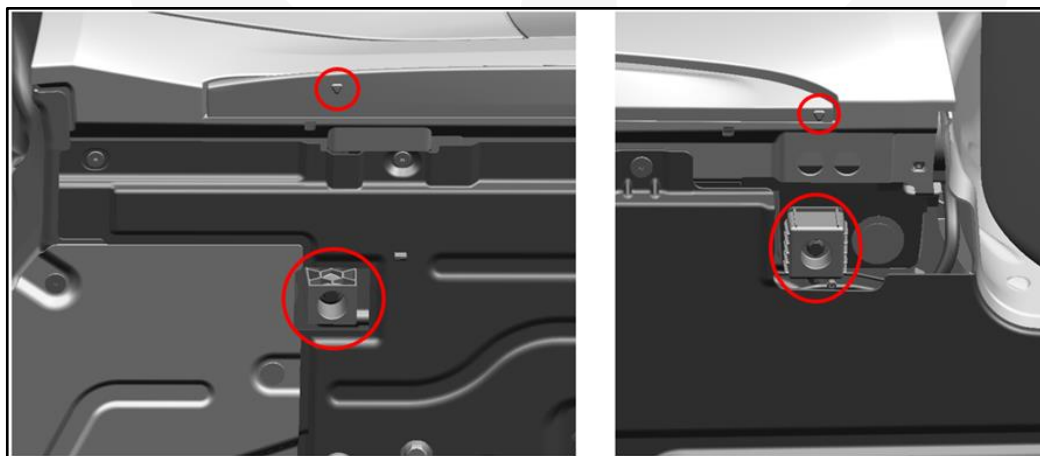

Front pad

Rear pad

Be careful about the axle geometry to prevent damaging the vehicle during the lifting operation. We recommend removing all possible loads from the vehicle (passengers, luggage, spare tire, etc.) to increase the distance from the ground (in case there are no air springs). We recommend using lift plates with a diameter no greater than 125mm for the front axle and centering the plate on the lifting dowel as well as possible to prevent contact with the car's floor trim.



2.2 Door Opening

The following diagram summarizes the instructions in the On-board Documentation concerning the door opening controls:

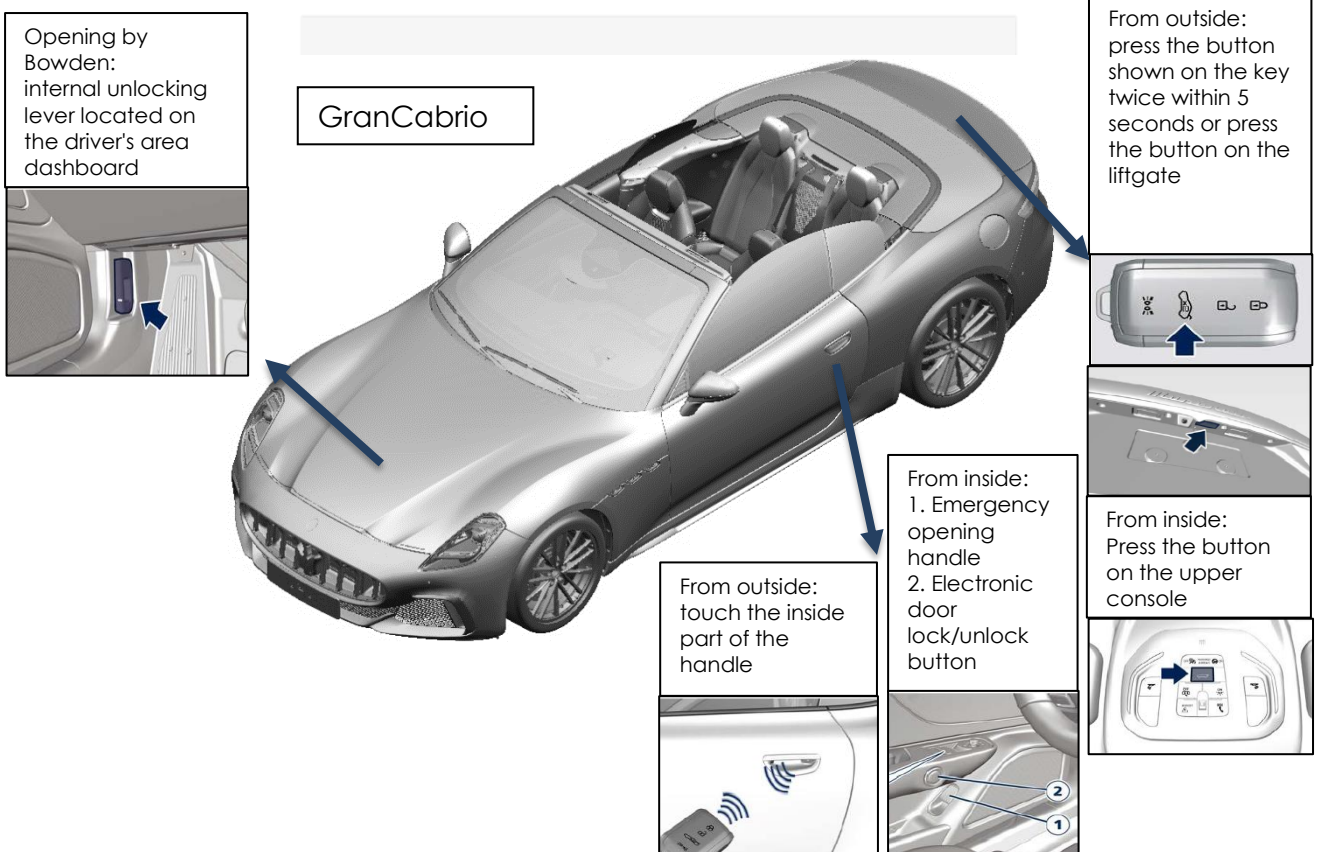
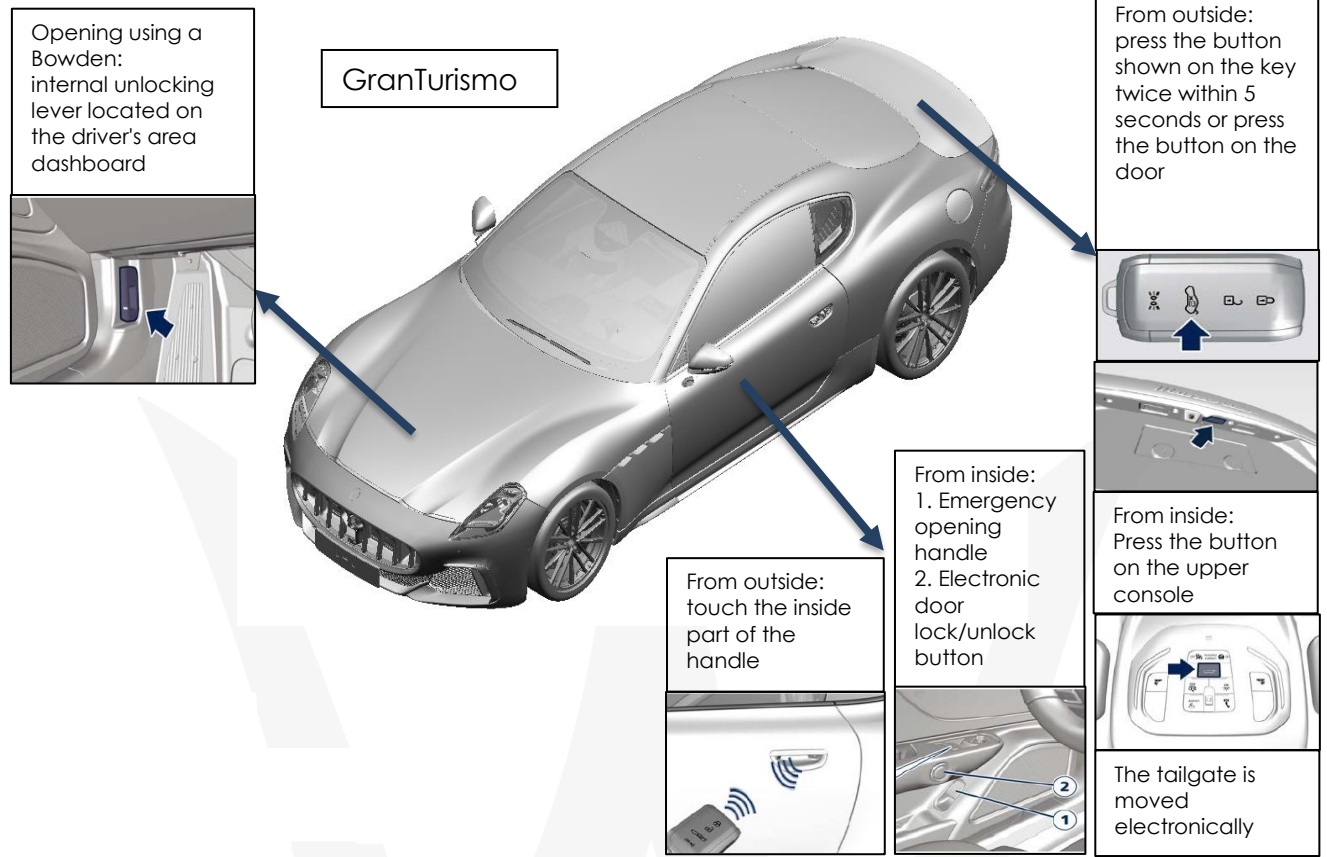

The electric locks cannot be powered if the 12 V battery is dead. The key fob has an emergency mechanical key that can unlock the driver's side door with a lock corresponding to the handle itself, as shown in the figure below:

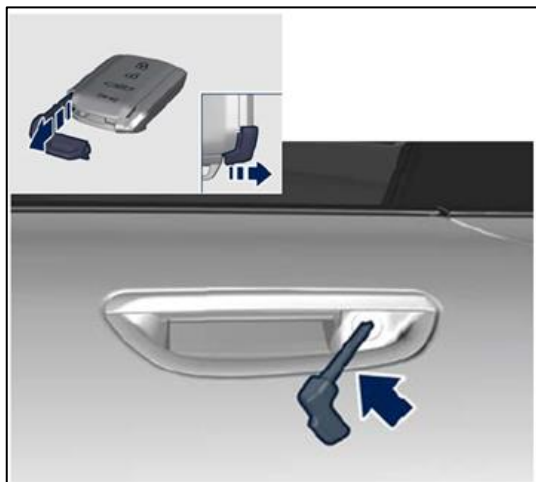

The liftgate can be opened mechanically from inside the vehicle by pulling the glow-in-the-dark emergency release lever located on the inside of the trunk lid trim.



The movement of the GranCabrio's soft top is controlled by an electro-hydraulic system, which can be activated using the dedicated controls on the central display of the vehicle. The opening/closing movement of the soft top can be interrupted by stopping applying pressure on the control; however, it is recommended to always carry out the complete opening or closing cycle, unless strictly necessary; this is because after approximately 7 minutes the electro-hydraulic movement system deactivates, leaving the soft top free to move if it is not in the stable position of complete opening or closing; this condition, if not controlled, can lead to a risk to personnel and the car itself. Please also note that, in the event of failure of the automatic movement system, the soft top can be moved manually; for all the details about the emergency handling procedure, please refer to the on-board documentation.

2.3 12V Battery location

The battery is in the inner middle side of the trunk. To access the battery, lift the panel on the bottom of the boot and remove the toolbox.

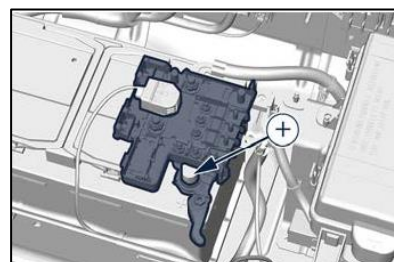
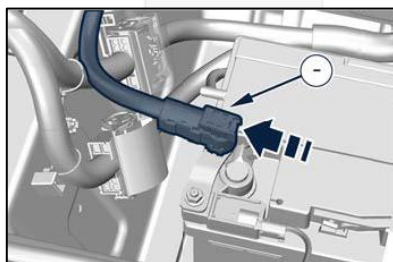
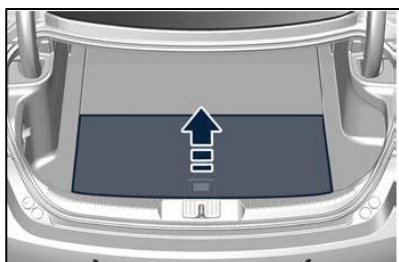

2.4 Disconnect the 12V Battery negative cable.

If you need to disconnect the 12V battery negative cable (for example, due to long vehicle inactivity), you can access it by removing the bottom cover of the rear trunk:

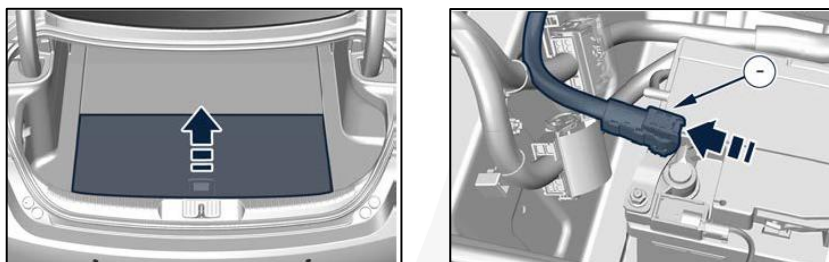

2.5 Emergency start - dead Battery

If an emergency start is needed for a dead battery, the remote poles located in the engine compartment can be used, as indicated in the following figures:

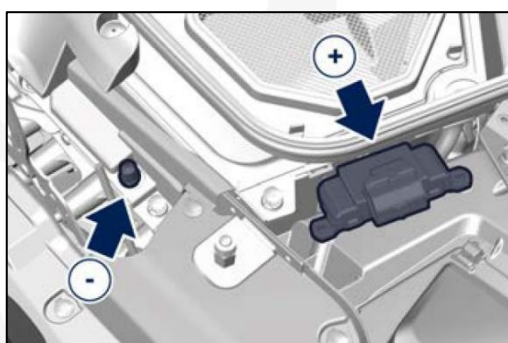

2.6 Transmission Park Release

If you need to move the car with the engine off, the "Car Wash" mode can be activated. As shown below:

- The car must be on a level surface, not moving.
- Put the transmission in N (Neutral) by using the control on the dashboard.

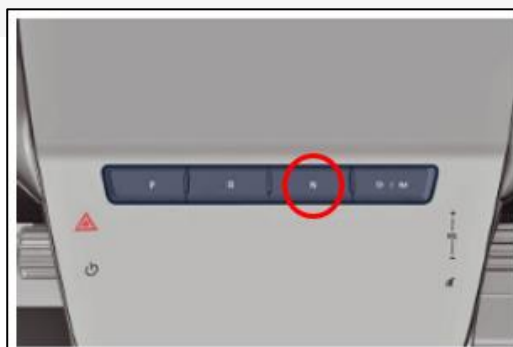

- Turn the engine off by pressing the START/STOP button.

The driver's door must be shut during these steps. This condition must be maintained for about 15 minutes, after which the transmission moves to P (Park).

If this solution is not possible or if there are other transmission problems, the transmission can be released manually as follows:

- Lift the car just enough to be able to reach the inside central area.
- Identify the automatic transmission and the release actuator lever.

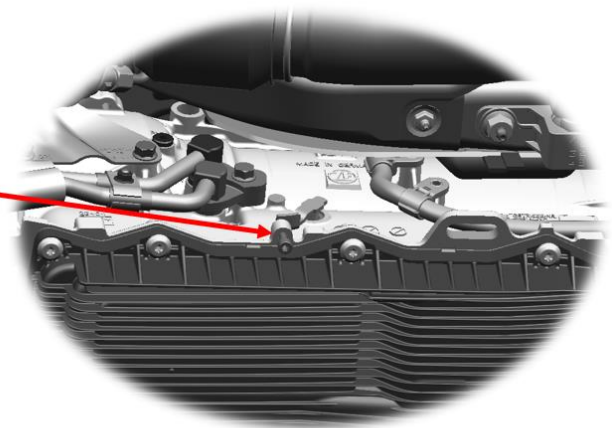
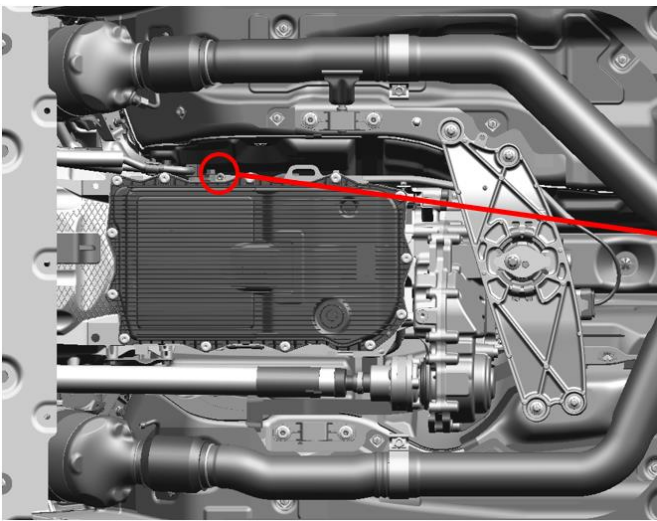

Warning: the transmission park release lever actuator is not in the car: you need to use an M6 screw at least 32.4 mm long.

3 Pre-Delivery Inspection Checklist

To support you in delivering the new Maserati GranTurismo/GranCabrio, we have developed a specific Checklist, adding new checks to test the new features and ensure that the customer can drive the car with maximum satisfaction. In addition, some policies regarding the control of the charge status of the 12V battery have been modified. The PDI CHECKLIST is included with this bulletin in Modis.

The Checklist will guide you through the various stages of vehicle inspection and preparation. Each Checklist includes a set of actions and procedures to be carried out on each car during the PDI. At the end of each car preparation, we ask you to keep a copy of the Checklist, signed by the technician who has performed the checks, to support process traceability that could be helpful to improve the quality of the service offered, where necessary. Maserati could also request a copy of the same during the contractual warranty period for statistical purposes for its product improvement processes.

PDI procedure to carry out with MDEvo

The warranty start date and "Customer Mode" setting to be performed during PDI are described in Circular Letter MAS003368 (and corresponding updates).

4 Activation of the technical team

A cross-functional Technical Team has been established, comprising individuals from Product Support, Engineering, Quality, Spare Parts, Customer Care, and RAM departments. In addition to introducing innovative technical content, the team is dedicated to offering comprehensive support for accurate diagnosis and resolution during initial interventions within the network. Furthermore, they aim to conduct swift and effective investigations into all reported anomalies. **For details on submitting BOLs to report anomalies, please consult the latest "Blue On Line Policy Update" Bulletin.**

To monitor the correct progress of the vehicle repair on new models and ensure corrective action for anomalies found during PDI. Maximum care is required in manually setting the Service Entry status. Please also remember that the Service Entry status is automatically set up in "Awaiting Spare Parts" when the parts to be replaced are related to interventions covered by the contractual warranty and ordered in VOR mode. With a view to product improvement and to allow Maserati to improve the diagnostic effectiveness, you will also need to analyze promptly the defective components replaced. For this purpose, applying the following indications for the entire duration of the Technical Team is required:

1. Warranty claim must be entered within two working days of closing the Service Entry.
2. Components replaced and requested for urgent return must be sent within two working days of receiving the request. Please refer to the Maserati warrant urgent parts return bulletin in Modis for details.

5 Technical Documents and Special Tools

5.1 Technical Information

TechDocs has been updated to include technical documentation for the new GranTurismo:

- Parts catalog
- Labor Times
- Workshop Manual
- Wiring Diagrams
- Diagnostic Help

5.2 Special Tools

Maserati has created a set of special tools specifically for the new GranTurismo and GranCabrio to ensure the highest levels of quality in driving assistance and safety. Such mandatory tools will be supplied automatically and will also be present on the ModisCS+ Special Tool Catalog. The tools created are listed below in the table, along with a brief technical description:

Maserati P/N	WSM tools
900030939 (900030834+900084564)	Engine-transmission removal tool upgrade
900030836	Rear axle removal tool upgrade
900030837	Manual liftgate lock release tool
900030838	Instrument cluster release tool
900030839	Front-wheel toe-in tool
900030842	Tensioner
900030800	Damper anti-torque removal and refitting
900030841	Hub nut tool lever
Maserati P/N	Bodywork jigs
900030843	Global Jig Kit
900030844	CarBench Jig Kit
Maserati P/N	Soft Top Tools
900100010	Soft top support rod
900100009	Soft top fixing brackets

- **Engine-transmission removal tool upgrade (900030939)**: This front removal tool upgrade will be used for removing and refitting the engine and transmission.
- **Rear axle towing tool upgrade (900030836)**: This rear axle towing tool upgrade will be used for assembling and disassembling the rear suspension chassis.
- **Manual liftgate lock release tool (900030837)**: This tool allows the liftgate to be opened from the compartment in the center of the rear seats.
- **Instrument cluster release tool (900030838)**: This tool allows the instrument cluster to be removed without damaging the display.
- **Front-wheel toe-in tool (900030839)**: This tool allows the correct torque tightening of the front wheel toe-in tie rod nut after aligning the car.
- **Tensioner (900030842)**: This tool allows the manual handling of the belt tensioner for removal and refitting.
- **Damper anti-torque removal-refitting (900030800)**: This tool is used to create the necessary counter-torque when removing the engine damper.
- **Hub nut tool lever (900030841)**: This tool is an upgrade of PN 900029761 and allows easier use. The tool introduced for M189 applies to all other cars where 900029761 is required.
- **M189 CarBench Jig Kit (900030844)**: To be used with the jigs already in the workshop's possession, will allow you to check and repair the bodywork of the car correctly for both engine versions.
- **M189 Global Jig Kit (900030843)**: To be used with the templates already in the workshops' possession, will allow you to check and repair the vehicle's bodywork correctly for both engine versions.