

Technical Service Bulletin

| | |
|------------------------|--|
| Topic | New Continental GT/C & New Flying Spur - Air suspension warning light in the DIP |
| Market area | Australia E04 Bentley rest Asia and Australia (6E04),China 723 Volkswagen (Anhui) Automotive CO (6723),China 796 VW Import Comp. Ltd (Vico), Beijing (6796),Germany E02 Bentley rest Europe (6E02),Japan E03 Bentley Japan (6E03),Korea, (South) E08 Bentley South Korea (6E08),United Arab Emirates E06 Bentley Middle East and Africa (6E06), United Kingdom E01 Bentley UK (6E01),United States E05 Bentley USA and rest America (6E05) |
| Brand | Bentley |
| Transaction No. | 2070768/2 |
| Level | EH |
| Status | Released for publishing |
| Release date | Jun 30, 2025 |

New customer code

| Object of complaint | Complaint type | Position |
|---|--|----------|
| information, navigation, communication, entertainment -> indicator display symbols -> driving dynamics regulation (ESC) indicator display | functionality -> activates without cause | |
| chassis -> damping\suspension regulation -> roll compensation | functionality -> operation sequence incorrect | |
| lighting, signaling -> acoustic signals -> warning signal for damper /suspension regulation | functionality -> warning tone sounds without cause | |
| information, navigation, communication, entertainment -> information display symbols -> stabilizer bar decoupling indicator display | functionality -> activates without cause | |

Vehicle data

New Continental GT/C and New Flying Spur

Sales types

| Type | MY | Brand | Designation | Engine code | Gearbox code | Final drive code |
|------|------|-------|-------------|-------------|--------------|------------------|
| 3S3* | 2024 | E | | * | * | * |
| ZG2* | 2024 | E | | * | * | * |
| ZG2* | 2022 | E | | * | * | * |
| ZG2* | 2023 | E | | * | * | * |
| 3S3* | 2020 | E | | * | * | * |
| ZG2* | 2020 | E | | * | * | * |
| 3S3* | 2021 | E | | * | * | * |
| ZG2* | 2021 | E | | * | * | * |

| | | | | | | |
|------|------|---|--|---|---|---|
| 3S3* | 2022 | E | | * | * | * |
| 3S3* | 2023 | E | | * | * | * |
| 3S4* | 2019 | E | | * | * | * |
| 3S4* | 2020 | E | | * | * | * |
| 3S4* | 2021 | E | | * | * | * |
| 3S4* | 2022 | E | | * | * | * |
| 3S4* | 2023 | E | | * | * | * |
| 3S4* | 2024 | E | | * | * | * |
| 3S3* | 2018 | E | | * | * | * |
| 3S3* | 2019 | E | | * | * | * |

Documents

| |
|----------------------------|
| Document name |
| master.xml |

Condition

Customer statement:

Air suspension warning light within the DIP

Workshop findings:

Various suspension DTC's are evident within address 74 relating to the following:

- Level control valve mechanical malfunction

Or

- Solenoid for the level control system (Open circuit)

Technical Background



NOTE: An electrical integrity check must be conducted before replacing any parts

The solenoid valve block and/or control unit must be replaced first (symptom dependent) before replacing the air supply unit, in the event the issue is still evident and the air supply unit assembly is suspected as being at fault, the operative must request permission via DISS before replacing the air supply control unit assembly

Production Solution

Service

 **NOTICE**

Hint: Please also refer to TPI 2053492/- Air spring fault finding guidelines if the issue/symptom is not as described within this TPI

 **WARNING**

Vehicles which use a high voltage or 48 volt system MUST only be worked on by suitably qualified personnel

 **WARNING**

Please

ensure all guidelines within the repair manual are strictly followed when working on vehicles with a high voltage or 48 volt system

1) Referring to the applicable wiring diagram - Conduct a wiring integrity of the applicable air suspension circuits from NX7

NOTE: NX7 is located as shown in Figure 1

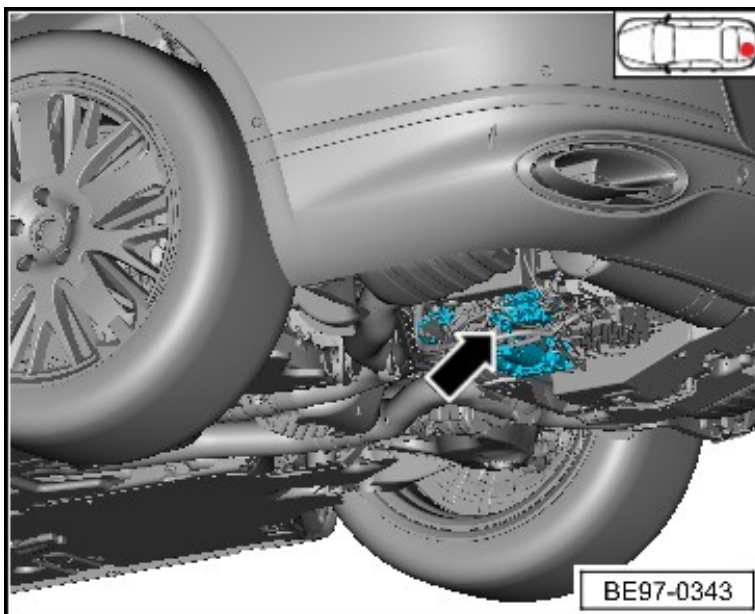

Figure 1

- Perform visual inspections of the connectors/pins, checking for damage and water ingress

TIP: Previous instances have highlighted the following after inspection:

- Broken wires
- Kinked wiring
- Pin/s missing
- Pin's broken
- Pin's loose

2) Repair any broken or damaged wires as per Rep.Gr 97



Should no issues be found regarding the integrity/visual checks, continue with the onward instructions noting the following:

In the event that a mechanical issue is suspected please conduct step 3

Or

Should an electrical issue be suspected please conduct step 4

3) Mechanical issue

In the event a mechanical issue is suspected, the operative should continue as follows:

NOTICE

In the event that one or a combination of the issues listed below is evident the operative must respond via a new or existing DISS query, the operative should attach clear photographs of the issues found and await feedback before proceeding

- Check for water ingress within the air supply unit/valve block
- Check for water ingress within the air supply hoses
- Check the air filter is not blocked
- Should none of the afore mentioned issues be evident - Replace the solenoid valve block (Figure 2) as detailed within Rep.Gr 43

Hint: The solenoid valve block can be replaced without the need to remove the air supply unit from the vehicle

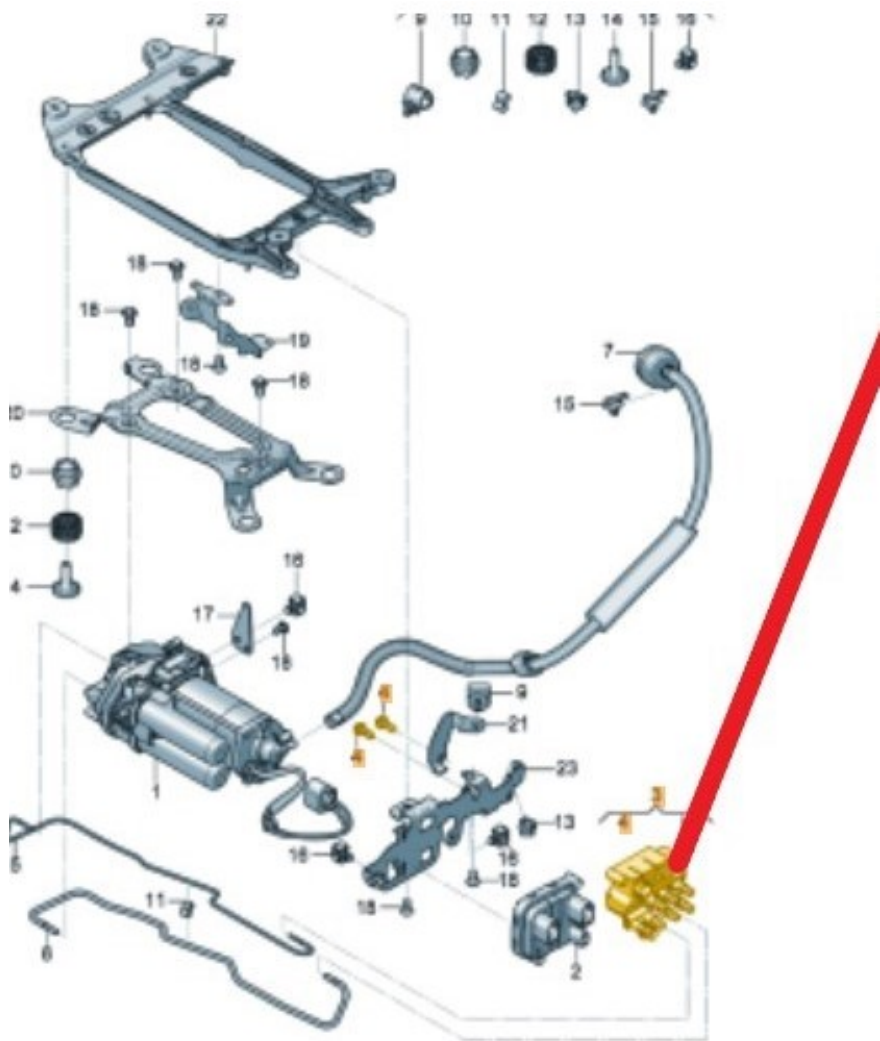

Figure 2

- Check to confirm the issue is now resolved and no DTC's are evident

NOTICE

Should the issue still be evident respond via a new or existing DISS query and await feedback before conducting any further work



Road test warranty claims will be cancelled, a road test is not required after conducting this process

4) Electrical issue

Should an electrical issue be evident issue and the wiring integrity checks were to specification, the operative should continue as follows:

- Referring to Rep.Gr43 (Air suspension compressor to remove and fit) - Replace the compressor control unit (Figure 3)

Hint: The compressor control unit can be replaced without the need to remove the air supply unit from the vehicle



The control unit is secured to the air supply unit bracket using (x4) clips - To remove the control unit disengage the clips using a non metallic tool then slide/remove the control unit from the bracket

TIP: The clips can easily snap - Take care when refitting the new control unit

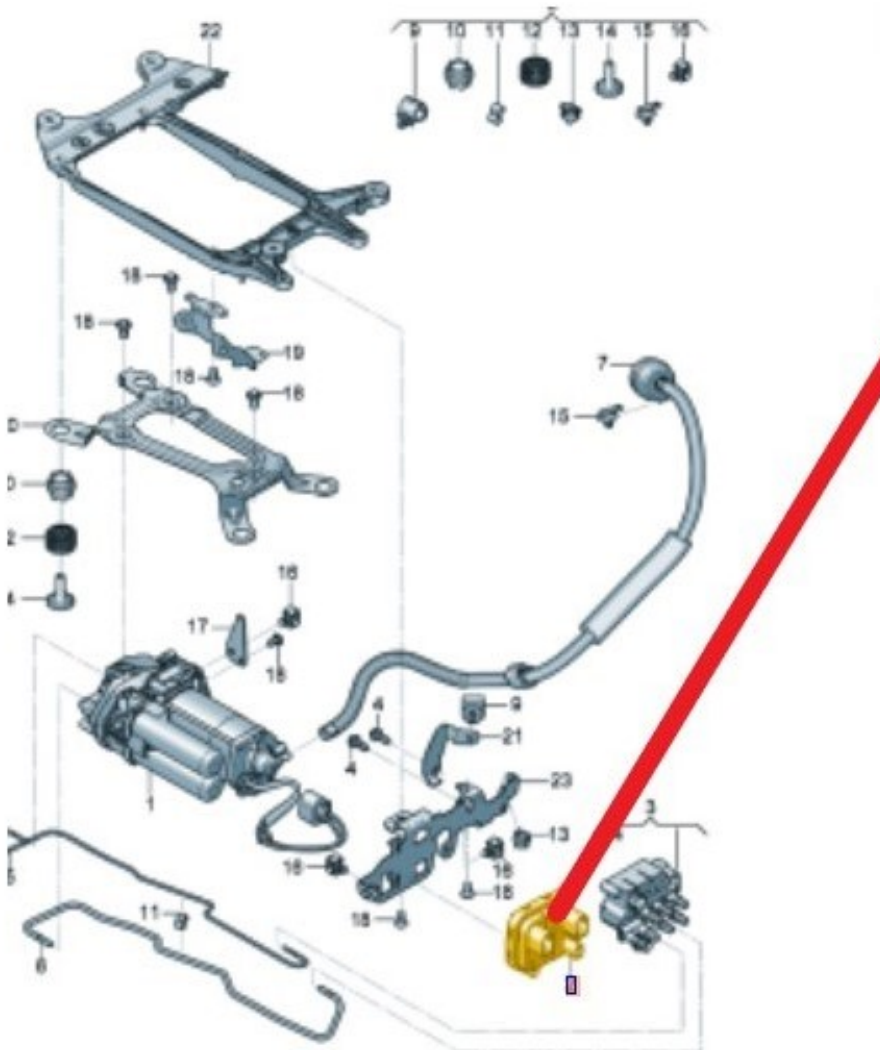

Figure 3

- Check to confirm the issue is now resolved and no DTC's are evident



NOTICE

Should the issue still be evident respond via a new or existing DISS query and await feedback before conducting any further work



Road test warranty claims will be cancelled, a road test is not required after conducting this process

Warranty

Warranty Type 110 or 910

Damage Service Number 43 23

Damage Code 00 15

Time to conduct wiring integrity checks

Labour Operation Code 43 13 01 10

Time 80 TU

Wiring repairs (where applicable)

Labour Operation Code 97 09 41 52

Time 40 TU

Time to replace the solenoid valve block (Mechanical operational issues/water ingress)

Labour Operation Code 43 23 19 00 (Use 99 index until 14.09.2023)

Time 40 TU

Time to remove and refit the control unit for adaptive suspension (Electrical issues)

Labour Operation Code 43 16 19 50 (Use 99 index until 14.09.2023)

Time 20 TU

Time to remove and refit the air supply unit (Must only be claimed if permission has been granted via DISS to replace the complete air supply unit)

Labour Operation Code 43 15 19 00

Time 90 TU

Diagnosis time using ODIS

Labour Operation Code 01 50 00 00

Time as per ODIS log (Must not exceed 10 TU)

Time to energise and de-energise the 48 volt system (Where applicable)

Labour Operation Code 93 10 00 00

Time 30 TU



Road test warranty claims will be cancelled, road test is not required after conducting this process

Required Parts and Tools

Refer to the ETKA parts catalogue