

July 9, 2025

Version 2

Warranty Extension: 2014–19 MDX and 2017–19 MDX Sport Hybrid - Moisture in the Inner Taillights

Supersedes 25-003 dated April 18, 2025, to revise the information highlighted in **yellow**.

APPLIES TO

Year	Model	Trim Level	VIN Range
2014–19	MDX	ALL	Check iN VIN status inquiry for eligibility.
2017–19	MDX Sport Hybrid	ALL	Check iN VIN status inquiry for eligibility.

REVISION SUMMARY

- Under TOOL INFORMATION, the note has been updated.
- Under WARRANTY INFORMATION, the warranty tables have been updated.
- Under REPAIR PROCEDURE, steps 10 and 16 have been updated.
- Under REPAIR PROCEDURE, the image in step 15 has been updated.
- Under REPAIR PROCEDURE, a note was added after step 24.

BACKGROUND

An uneven sealing surface allows moisture to enter the inner taillight(s), causing one or both of the inner taillights not to work.

NOTE:

- All Safety Recalls must be completed before this warranty extension can be applied.
- Acura is extending the warranty coverage on the inner taillights, related to this condition, to **9 years and unlimited mileage** from the original date of purchase.
- This warranty extension does not apply to any vehicle that has ever been declared a total loss or sold for salvage by a financial institution or insurer or has a branded or similar title under any state's law.

CLIENT NOTIFICATION

Owners of affected vehicles will be sent a notification of this campaign.
Do an iN VIN status inquiry to make sure the vehicle is shown as eligible.

CORRECTIVE ACTION

Inspect and, if necessary, replace the inner taillight(s).

CLIENT INFORMATION: The information in this bulletin is intended for use only by skilled technicians who have the proper tools, equipment, and training to correctly and safely maintain your vehicle. These procedures should not be attempted by “do-it-yourselfers,” and you should not assume this bulletin applies to your vehicle, or that your vehicle has the condition described. To determine whether this information applies, contact an authorized Acura automobile dealer.

PARTS INFORMATION

Part Name	Part Number	Quantity
Right Inner Taillight (RIGHT LID LIGHT ASSEMBLY)	34150-TZ5-H04	1
Left Inner Taillight (LEFT LID LIGHT ASSEMBLY)	34155-TZ5-H04	1
Right Inner Taillight (RIGHT LID LIGHT ASSEMBLY) (A-Spec)	34150-TZ5-A73	1
Left Inner Taillight (LEFT LID LIGHT ASSEMBLY) (A-Spec)	34155-TZ5-A73	1
Fuse (7.5A) (depending on trim level)	38221-SNA-A31	1
Fuse (10A) (depending on trim level)	38221-SNA-A41	1

REQUIRED MATERIALS

Part Name	Part Number	Quantity
Penguin 353 Sealer	08712-0010	1 (One Tube Will Repair 50 Vehicles)
Masking Tape	Commercially available	1

TOOL INFORMATION

Tool Name	Tool Number	Quantity
Sealant Template	07AAJ-TZ5A200	1
Body Clip (To hold the template)	91501-S04-003	2
3M Stripe Off Wheel with Hardware	MMM07498	1
3M Stripe Off Wheel (Wheel only)	MMM07499	1

NOTE:

- The maximum recommended RPM for the 3M Stripe Wheel is **4,000 RPM**.
- Each 3M Stripe Off Wheel can be used on **20 VINS** (**10 VINS** on each side of the wheel).

WARRANTY CLAIM INFORMATION

NON-A-SPEC

7141G3	Replace left inner taillight, check inner taillight harness, check fuse (includes inspection)	0.6 hr	6L800	QLL00	B25003A	34155-TZ5-A72
7141G4	Replace right inner taillight, check inner taillight harness, check fuse (includes inspection)	0.6 hr			B25003B	34150-TZ5-A72
7141G5	Replace both inner taillights, fuse, & check inner taillight harness (includes inspection)	0.8 hr			B25003C	34155-TZ5-A72

A-SPEC

7141G3	Replace sub harness, & left inner taillight (includes inspection)	0.6 hr	6L800	QLL00	B25003D	34155-TZ5-A72
7141G4	Replace sub harness, & right inner taillight (includes inspection)	0.6 hr			B25003E	34150-TZ5-A72
7141G5	Replace both inner taillights and fuse. Check inner taillight harness.	0.8 hr			B25003F	34155-TZ5-A72

INSPECTION PROCEDURE

1. Turn on the parking lights and check the taillight operation.

Inspection Result	Repair Direction
Inner taillights are working.	Go to step 2.
Both inner taillights are not working.	If the outer taillights are working, check the sub harness fuse (5A) and connections then replace both inner taillights.
One inner taillight is not working.	Replace the affected inner taillight.
Both outer and inner taillights are not working.	Proceed with normal troubleshooting.

2. Inspect for any signs of water intrusion into the inner taillight assemblies.
 - If water intrusion is found, replace the affected taillight(s). Go to REPAIR PROCEDURE.
 - If no water intrusion is found, no further action is required.

OUTER TAILLIGHT

INNER TAILLIGHT



WATER TRAPPED IN INNER TAILLIGHT

REPAIR PROCEDURE

NOTE:

- The new inner taillight sub harness is permanent and should never be removed.
- The inline fuse in the harness can be serviced by replacing the 5A fuse.

1. Open the tailgate.

NOTE: To prevent damage to the tailgate support struts, **do not** use the power tailgate function (if equipped) during the repair. Open and close the tailgate manually.

2. Remove the tailgate upper trim panel, then remove the side trim panels.

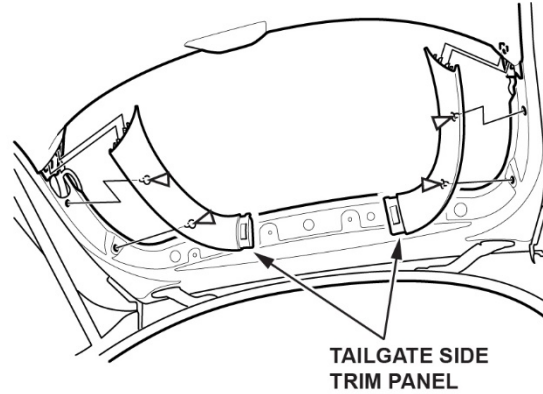
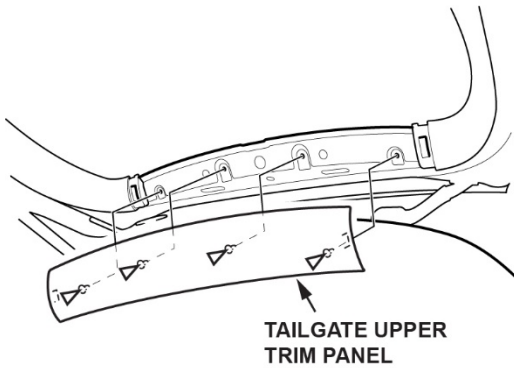

3. Remove the pull pocket, then disconnect the power tailgate switch connector.

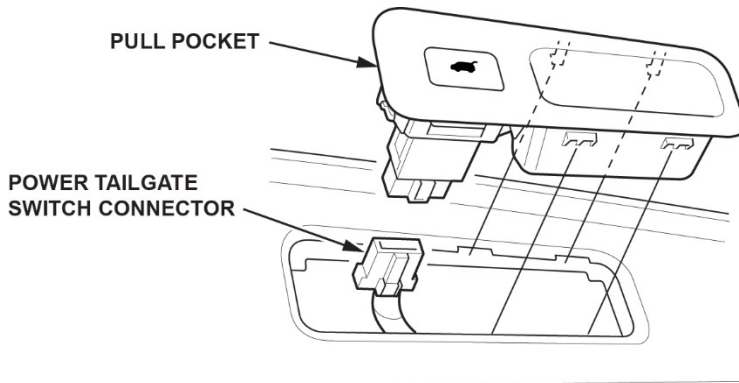

4. Remove and disconnect the tailgate light connectors.



- Remove the tailgate lower trim panel.

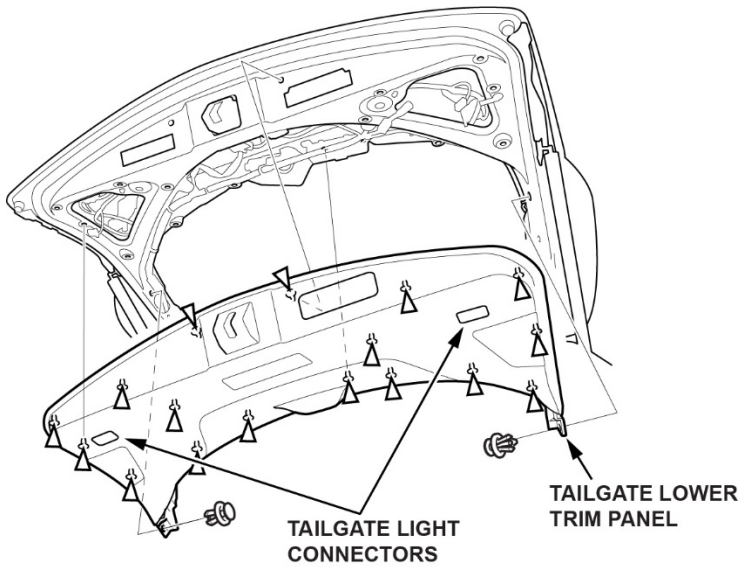

- Disconnect the license sub-harness connector, remove the five nuts, release the pins from the clips, then remove the rear license trim.

INSIDE THE TAILGATE

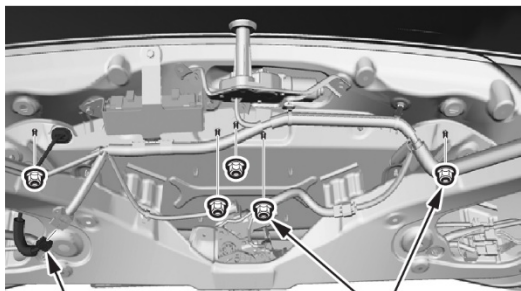

LICENSE SUBHARNESS CONNECTOR

4.9 N-m (3.6 lb-ft)

OUTSIDE THE TAILGATE

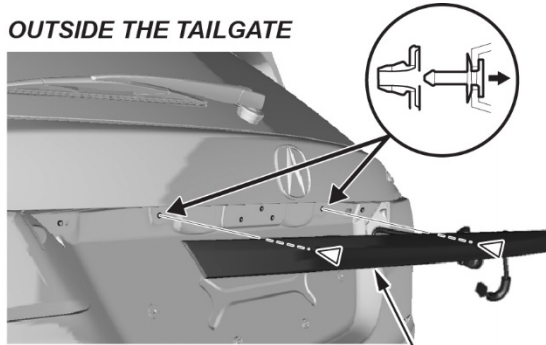

REAR LICENSE TRIM

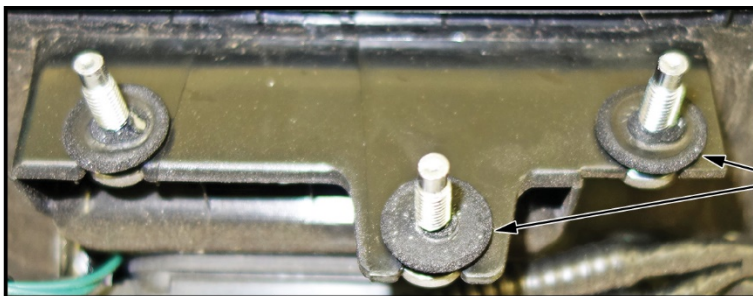

Be sure the grommets stay on the studs and clips.

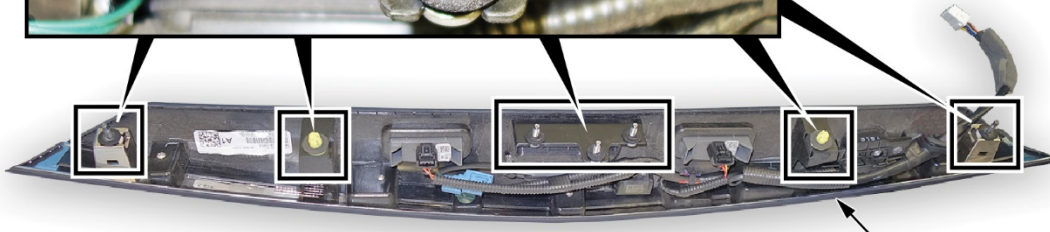

BACKSIDE OF THE REAR LICENSE TRIM

7. Disconnect both inner taillight connectors.

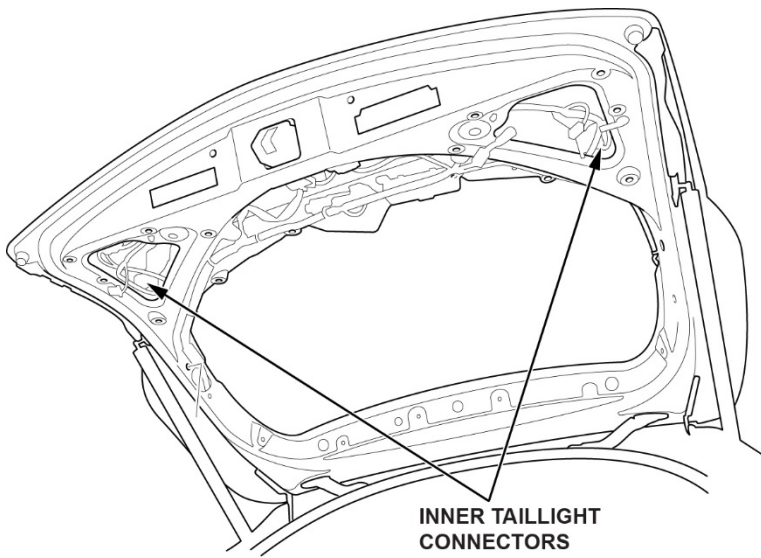

8. Remove the failed inner taillight(s) by removing the two mounting bolts and two mounting nuts.

NOTE: Be sure to completely remove the old inner taillight gasket from the tailgate surface.

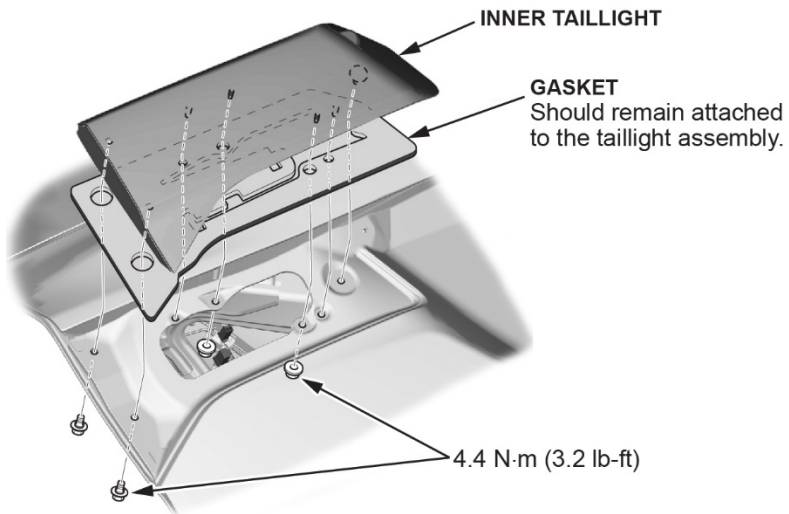

Dust Sealer Removal

NOTE: Only remove the sealer from the failed inner taillight that was just removed.

9. Install the template to the inner taillight location on the tailgate using the body clips.
10. Use the top edge of the template to mark the area **with a marker** where the dust sealer needs to be removed. The sealer should be removed from between the vertical lines, and along the edge of the template.

NOTE: There should be no dust sealer remaining inside the marked area.

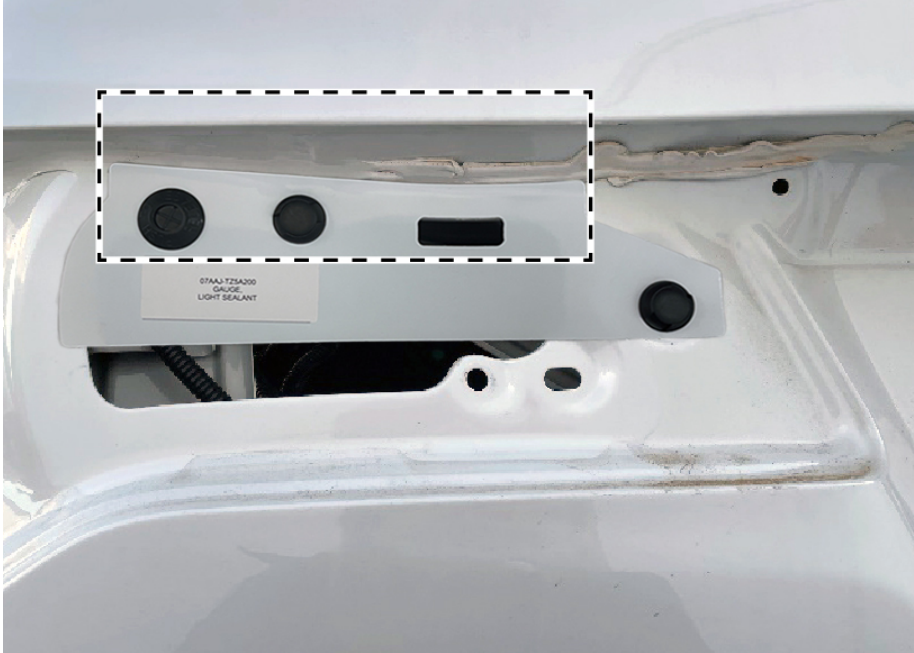

11. Once the dust sealer removal area has been marked, remove the template.
12. Seal the tailgate before doing the dust sealer removal:
 1. Place tape over the opening for the lid light.
 2. From the inside of the tailgate, place tape over the opening for the inner taillight.

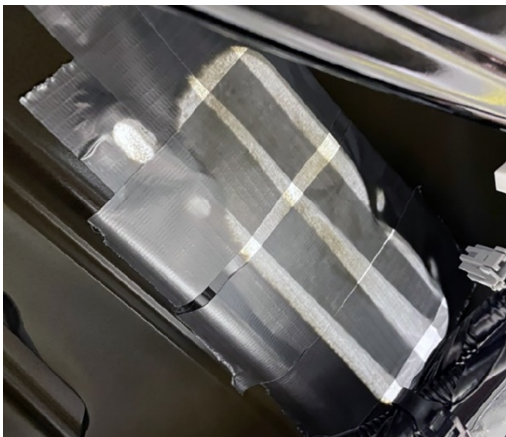

13. Place tape over the edge of the outer taillight to keep debris from getting into the housing.



14. With the tailgate closed, and while wearing proper eye protection, use a drill (or equivalent rotary tool) with the 3M Stripe Off Wheel to remove the dust sealer between the markings.

NOTE:

- Ensure that the power tool being used is appropriate for the type of stripe off wheel being used.
- The maximum RPM for the recommended 3M Stripe Off Wheel is **4,000 RPM**.
- The stripe off wheel will only remove paint where there is sealer underneath the paint.

3M STRIPE OFF WHEEL



HARDWARE (SCREW)



15. Use the template as a guide to ensure enough sealer has been removed.

NOTE: If the template indicates that additional sealer needs to be removed, remove the template, then continue to remove sealer as needed with the stripe off wheel.



Example of finished sealer removal:



16. Place a tracking mark on the center of the stripe off wheel after each VIN is repaired. When 10 VINs have been completed (10 tracking marks have been added), flip the wheel over and repeat the process for 10 more VINs. After 20 VINs have been completed (10 tracking marks on each side of the wheel), replace the stripe off wheel with a new wheel.

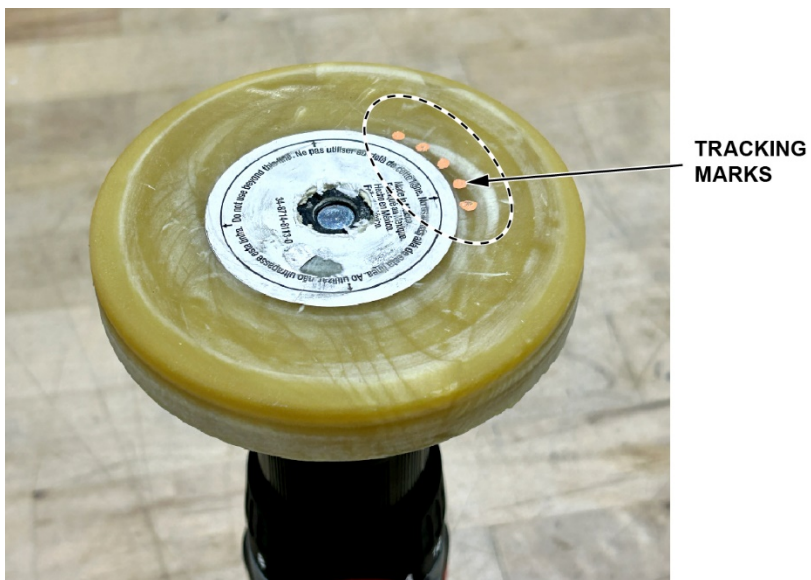

Apply Sealer

17. With the template installed, use a marker to make a line across the top edge of the template, then remove the template.



18. Place tape along the underside of the line that was drawn in the previous step.

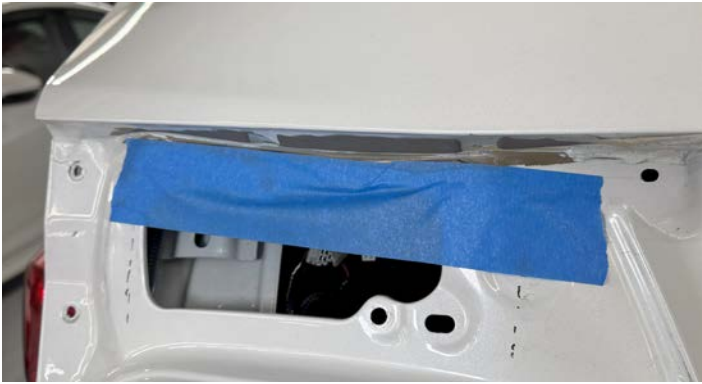

19. Apply a thin bead of Penguin Seal 353 to the area above the tape where the tailgate panels meet. While wearing a glove, run a finger along the new sealer to seal the panel joint and smooth the sealer across the area where the old sealer was removed.



20. Immediately remove the tape below the sealer and allow 15 minutes for the sealer to dry.

NOTE: You can proceed to the next step while the sealer is drying.



21. Remove the remaining masking materials from the outer taillight and inside the tailgate.

Inner Taillight Installation

22. Install the new inner taillight(s) and connect them.

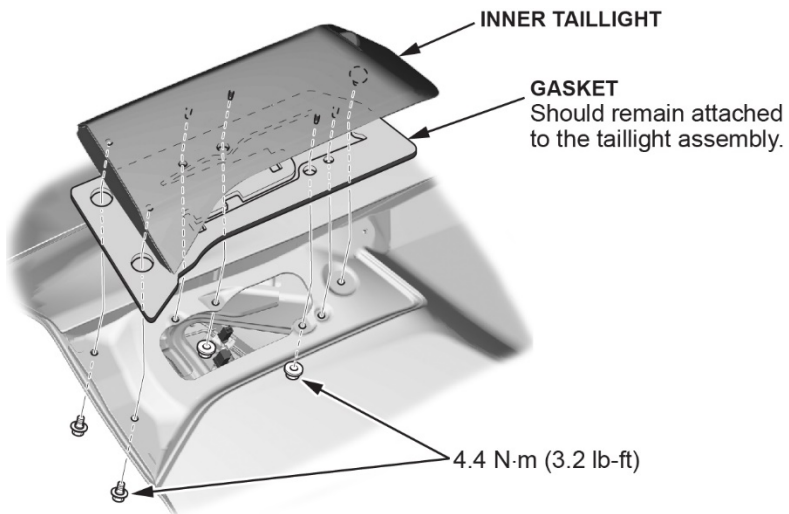

23. Make sure all the taillights come on.

24. Install all remaining parts in the reverse order of removal.

NOTE: The new inner taillight sub harness is permanent and should never be removed. The inline fuse in the sub-harness can be serviced by replacing the 5 A fuse.