

July 18, 2025

Version 2

## Warranty Extension: 2013–17 Odyssey MIL Comes on with DTCs P0301 Thru P0304 (6 months)

Supersedes Version 1, dated June 17, 2025, to revise the information highlighted in **yellow**.

### APPLIES TO

Year	Model	Trim Level	VIN Range
2013–17	Odyssey	ALL	Check the iN VIN status for eligibility.

### REVISION SUMMARY

Under PARTS INFORMATION, REPAIR PROCEDURE A, a part was removed.

### BACKGROUND

The piston ring function deteriorates due to ring wear and sticking from sludge. Oil from the crankcase adheres to the spark plug leading to carbon fouling and misfire. This can set DTCs P0301 No. 1 cylinder misfire detected, P0302 No. 2 cylinder misfire detected, P0303 No. 3 cylinder misfire detected, P0304 No. 4 cylinder misfire detected, and cause the MIL to come on.

American Honda is extending the warranty coverage for this condition to **January 31, 2026**. Any repair orders issued after that date are no longer valid.

### CUSTOMER NOTIFICATION

Owners of affected vehicles will be sent a notification of this campaign.

Do an iN VIN status inquiry to make sure the vehicle is shown as eligible.

### CORRECTIVE ACTION

Complete the DIAGNOSIS PROCEDURE and, if necessary, update the PCM software, replace affected spark plugs then clean pistons and replace the piston rings. If cylinder inspection fails, perform engine block replacement, replace affected spark plugs, and update the PCM software.

Additionally, the following videos are available to help with this bulletin:

- Tech2Tech: ["How to Clean Piston Ring Grooves"](#)
- Tech2Tech: ["Let's Talk Piston Ring Compressors"](#)
- Tech2Tech: ["Cylinder Wall Inspection Tool"](#)

**CUSTOMER INFORMATION:** The information in this bulletin is intended for use only by skilled technicians who have the proper tools, equipment, and training to correctly and safely maintain your vehicle. These procedures should not be attempted by "do-it-yourselfers," and you should not assume this bulletin applies to your vehicle, or that your vehicle has the condition described. To determine whether this information applies, contact an authorized Honda automobile dealer.

## WARRANTY CLAIM INFORMATION

**FLAT RATE NOTE:** The procedure in this bulletin is different than the service manual. This procedure does not require the complete removal of the power steering pump, catalytic converter(s), engine and transmission, or the crankshaft. As a result, the operation number is unique and the FRT is reduced (**Repair Procedure A**)

### DTC P0301, P0302, or P0303

#### No scratching or scoring detected

Operation Number	Description	Flat Rate Time	Defect Code	Symptom Code	Template ID	Failed Part Number
1115A7	<b>DTC P0301, P0302 or P0303:</b> Inspect spark plug(s)	0.3hr	6Z600	QLT00	A25061A	13021-5G0-A01
A	<b>Repair procedure A:</b> Remove cylinder head, inspect cylinders, clean pistons 1-3, replace piston rings 1-3 and replace spark plugs 1-4 (includes idle learn)	8.3hr				
C	Update the PCM software (includes DTC clear)	0.1hr				

#### Scratching or scoring detected

Operation Number	Description	Flat Rate Time	Defect Code	Symptom Code	Template ID	Failed Part Number
1115A7	<b>DTC P0301, P0302 or P0303:</b> Inspect spark plug(s)	0.3hr	6Z600	QLT00	A25061B	13021-5G0-A01
B	<b>Repair procedure B:</b> Remove cylinder head, inspect cylinders, replace short block and replace spark plugs 1-4 (includes Idle learn & align)	11.1				
C	Update the PCM software (includes DTC clear)	0.1hr				

**DTC P0304****No scratching or scoring detected**

Operation Number	Description	Flat Rate Time	Defect Code	Symptom Code	Template ID	Failed Part Number
1115A8	<b>DTC P0304:</b> Inspect spark plug(s)	0.3hr	6Z600	QLT00	A25061C	13021-5G0-A01
A	<b>Repair procedure A:</b> Remove cylinder heads, inspect cylinders, clean pistons 1-4, replace piston rings 1-4 and replace spark plugs 1-4 (includes idle learn)	9.1hr				
C	Update the PCM software (includes DTC clear)	0.1hr				

**Scratching or scoring detected**

Operation Number	Description	Flat Rate Time	Defect Code	Symptom Code	Template ID	Failed Part Number
1115A8	<b>DTC P0304:</b> Inspect spark plug(s)	0.3hr	6Z600	QLT00	A25061D	13021-5G0-A01
B	<b>Repair procedure B:</b> Remove cylinder heads, inspect cylinders, replace short block and replace spark plugs 1-4 (includes Idle learn & align)	11.1hr				
C	Update the PCM software (includes DTC clear)	0.1hr				

**PARTS INFORMATION**

**Repair Procedure A: Piston Cleaning and Ring Replacement**

Part Name	Part Number	Quantity	
		Cyl 1-3	Cyl 1-4
Cyl. Gasket (Fr)	12251-R70-A01	-	1
Cyl. Gasket (Rr)	12261-R70-A01	1	1
Drain Washer 14 mm	94109-14000	1	1
EGR Pipe Gasket A	18716-R70-A01	1	1
EGR Pipe Gasket B	18719-R70-A01	1	1
Ex. Chamber Gasket	18115-R70-A01 or 18115-5G0-A01	1	2
Ex. Pipe Gasket	18212-SA7-003	2	2
Head Gasket Fr. (Valve Cover)	12030-R70-A00	-	1
Head Gasket Rr. (Valve Cover)	12050-R70-A00	1	1
In. Manifold Gasket (Intake Top Cover)	17146-R70-A01	1	1
In. Manifold Gasket (In. Manifold to Base)	17105-RCJ-A01	1	1
Oil Filter	15400-RTA-003	1	1
O-ring (7.47 mm x 3.6 mm)	91301-PLC-000	2	2
O-ring (31.2 mm x 4.1 mm)	91314-PH7-003	2	2
Piston Ring Set	13011-RV0-305	3	4
Pre-chamber Gasket	18393-SDB-A00	1	1
Self-locking Nut (8 mm)	90212-RCA-A01	4	8
Self-locking Nut (10 mm)	90212-SA5-003	9	9
Spark Plug	12290-R71-L01	4	4
Strainer O-ring	15221-RYE-A01	1	1
Bolt, Flange (side engine mount bolts)	90164-SHJ-A00	2	2
Bolt, Flange (12 x 115) (side engine mount bolt)	90161-SZA-A00	1	1

**Repair Procedure A: Piston Cleaning and Ring Replacement – cont.**

Part Name	Part Number	Quantity	
		Cyl 1-3	Cyl 1-4
Timing Belt Bolt	14551-RCA-A01	1	1
Water Gasket Fr.	19411-P8A-A03	1	1
Water Gasket Rr.	19412-P8A-A02	1	1

**Replace parts as needed for Repair Procedure A**

Part Name	Part Number	Quantity	
		Cyl 1-3	Cyl 1-4
Connecting Rod Bolt (may require up to 2 bolts per connecting rod)	13204-P8A-A01	6	8
Washer-Bolt (12 x 163) (may require up to 8 bolts per cylinder head)	90005-PAA-A01	8	16

**Repair Procedure B: Engine Short Block Replacement**

Part Name	Part Number	Quantity
Intake Cover Gasket	17146-R70-A01	1
Intake Manifold Gasket	17105-RCJ-A01	1
Water Gasket Fr.	19411-P8A-A03	1
Water Gasket Rr.	19412-P8A-A02	1
Catalytic Converter Gasket	18115-R70-A01 or 18115-5G0-A01	2
Oil Filter	15400-PLM-A02	1
Nut, Self-Locking (catalytic convertor)	90212-RCA-A01	8
Washer, Sealing (24 mm) (6AT Fill Plug Washer)	11107-PWA-300	1
Washer, Drain Plug (18 mm) (6AT Drain Plug Washer)	90471-PX4-000	1
Washer, Drain Plug (20 mm) (5AT Drain Plug Washer)	94109-20000	1
Gasket, Prechamber	18393-SDB-A00	1
Gasket, Exhaust Pipe	18212-SA7-003	2
Nut, Self-Lock (10 mm) (Exhaust pipe A nuts)	90212-SA5-003	9
Bolt, Flange (side mount bolt to frame bracket)	90163-SDA-A01	2
Bolt, Flange (side engine mount bolts)	90164-SHJ-A00	2
Bolt, Flange (12 x 115) (side engine mount bolt)	90161-SZA-A00	1
Bolt, Flange (10 x 20) (Front & Rear engine mount bolts)	90163-S5A-000	8

**Repair Procedure B: Engine Short Block Replacement – cont.**

<b>Part Name</b>	<b>Part Number</b>	<b>Quantity</b>
Nut, Flange (12 mm) (Front & Rear Engine Mount stopper nuts)	90371-SAA-010	4
Bolt, Flange (10 x 75) (Rear engine mount bolts)	95701-12065-08	2
Bolt, Flange (10 x 50)	95701-10050-08	4
Bolt, Flange (10 x 120)	95801-10120-08	2
Bolt, Flange (10 x 30) (Front engine mount bracket bolts)	90163-SDB-A00	3
Bolt, Flange (12 x 83) (Rear engine mount bracket bolts)	90163-SHJ-A00	4
O-RING (14.4 x 1.9) (P.S Line)	91370-TA0-000	1
O-Ring (fuel rail O-ring)	91301-PLC-000	2
Starter Motor Gasket	31270-RJA-A01	1
Gasket A, EGR Pipe (EGR pipe gasket)	18716-R70-A01	1
Gasket B, EGR Pipe (EGR pipe gasket)	18719-R70-A01	1
Gasket, Rear Cylinder (head gasket)	12261-R70-A01	1
Gasket, Front Cylinder (head gasket)	12251-R70-A01	1
Head Gasket Fr. (Valve Cover)	12030-R70-A00	1
Head Gasket Rr. (Valve Cover)	12050-R70-A00	1
O-Ring (O-rings for coolant pipe)	91314-PH7-003	2
Timing Belt Bolt	14551-RCA-A01	1
Bolt, Timing Belt Adjuster	14513-RCA-A01	1
Bolt, Flange (strut to knuckle)	90119-SHJ-A00	4
Nut, Flange (strut to knuckle)	90382-SP0-003	4
Bolt, Flange (special bolt, subframe)	90165-TK8-A00	4
Bolt, Flange (special bolt; rear subframe bolt)	90161-SHJ-A00	2
Bolt, Flange (12 x 28) (subframe bracket bolt)	90181-SK3-E00	2
O-Ring (15 x 1.9) (CKP O-ring)	91333-PNA-003	1
O-Ring (8.8 x 2.4)	15142-P8A-A00	2
Engine Short Block (2013-2017)	10002-RV0-305	1

**Replace parts as needed for Repair Procedure B**

Part Name	Part Number	Quantity	
		Cyl 1-3	Cyl 1-4
Washer-Bolt (12 x 163) (may require up to 8 bolts per cylinder head)	90005-PAA-A01	8	16

**REQUIRED MATERIALS****Repair Procedure A**

Part Name	Part Number	Quantity
Honda Long-Life Antifreeze/Coolant Type 2	08CLA-P99-0F0A8	3 gallons
Full Synthetic Engine Oil 0W-20 Oil	08798-9163	6 quarts
Hondabond HT (1 Tube Repairs 5 Vehicles)	08718-0004	1 tube
Genuine Honda Throttle Plate Cleaner	08700-TPCB	1
Nylon Parts Cleaning Brush	(commercially available)	
5/16 ID Flexible Hose (Block Drain)	(commercially available)	

**Repair Procedure B**

Part Name	Part Number	Quantity
Honda Long-Life Antifreeze/Coolant Type 2	08CLA-P99-0F0A8	3 gallons
Full Synthetic Engine Oil 0W-20 Oil	08798-9163	6 quarts
Power steering Fluid (12oz)	08206-9002	1
ATF-DW1	08200-9008	4
Hondabond HT (1 Tube Repairs 10 Vehicles)	08718-0004	1 tube
5/16 ID Flexible Hose	(commercially available)	1

## TOOL INFORMATION

### Repair Procedure A

Tool Name	Part Number	Quantity
Piston Ring Groove Cleaner	07AAZ-TA5A100	1
Cylinder Wall Inspection Tool	07AAJ-R70A301	1
Gasket Remover/Pan Separator	LIL50190	1
Piston Ring Expander	Snap-On PRS8 or equivalent	1
Piston Ring Compressor	SCP1287 or equivalent	1

NOTE: Each dealer has been sent one cylinder wall inspection tool.

### Repair Procedure B

Tool Name	Part Number	Quantity
Lift table	KLS6227500	1
Engine hoist	(commercially available)	1
Load leveler	NRI78115H	1
Cylinder Wall Inspection Tool	07AAJ-R70A301	1

NOTE: Each dealer has been sent one cylinder wall inspection tool.

## INSPECTION PROCEDURE

1. Connect the HDS and check for the following DTCs:

- P0301 No. 1 Cylinder Misfire Detected
- P0302 No. 2 Cylinder Misfire Detected
- P0303 No. 3 Cylinder Misfire Detected
- P0304 No. 4 Cylinder Misfire Detected

Are any of these DTCs stored?

**YES** – Go to step 2.

**NO** – Stop. This bulletin does not apply. Continue with normal troubleshooting.

2. Relieve the fuel pressure. ([Click Here](#))

3. Remove the engine cover, then remove the appropriate ignition coils, and spark plugs based on the DTCs stored.

Example: If P0301 is stored, remove the ignition coil on cylinder No. 1.

**FRONT**

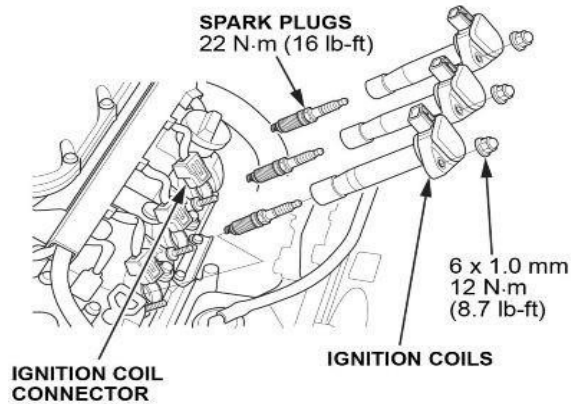

**REAR**

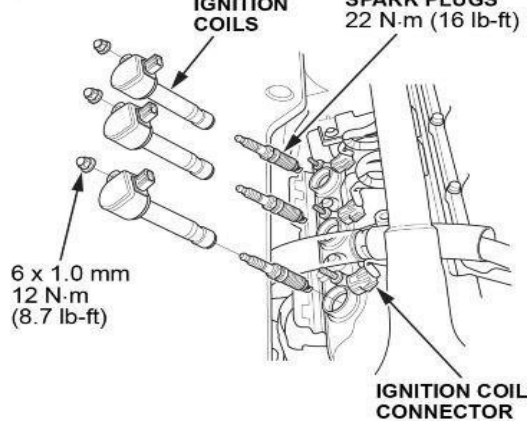

Cylinder Arrangement/Firing Order: 1-4-2-5-3-6

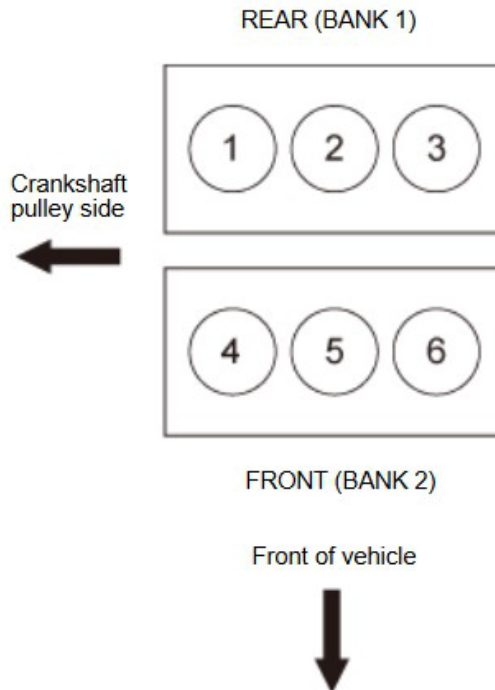

4. Remove and check the spark plug(s) of the affected cylinder(s).

Example: If P0301 is stored, check the spark plug on cylinder No. 1.

DTCs Stored	Diagnostic	Spark Plug Condition?	Repair Process
<b>P0301</b>	Remove the #1 cylinder spark plug and inspect for fouling.	Not fouled	This bulletin does not apply. Continue with normal troubleshooting.
		Fouled	Proceed to step 5.
<b>P0302</b>	Remove the #2 cylinder spark plug and inspect for fouling.	Not fouled	This bulletin does not apply. Continue with normal troubleshooting.
		Fouled	Proceed to step 5.
<b>P0303</b>	Remove the #3 cylinder spark plug and inspect for fouling.	Not fouled	This bulletin does not apply. Continue with normal troubleshooting.
		Fouled	Proceed to step 5.
<b>P0304</b>	Remove the #4 cylinder spark plug and inspect for fouling.	Not fouled	This bulletin does not apply. Continue with normal troubleshooting.
		Fouled	Proceed to step 5.
<b>P0305</b>			This bulletin does not apply. Continue with normal troubleshooting.
<b>P0306</b>			



5. Remove the affected cylinder head(s) to inspect the cylinder bores.

DTCs Stored with fouled spark plug(s)	Diagnostic
<b>P0301, P0302, or P0303</b>	Remove the <b>rear</b> cylinder head and inspect cylinder bores 1-3 for scratching or scoring using the cylinder wall inspection tool.
<b>P0304</b>	Remove the <b>front and rear</b> cylinder heads and inspect cylinder bores 1-4 for scratching or scoring using the cylinder wall inspection tool.

NOTICE

- Use fender covers to avoid damaging painted surfaces.
  - To avoid damaging any wires and terminals, unplug the circuit connectors carefully while holding the connector portion.
  - Mark all the circuits and hoses to avoid misconnection. Make sure they do not contact other circuit wiring, hoses, or interfere with other parts.
1. Remove both front wheels so you can fully lower the vehicle.
  2. Disconnect and remove the 12-volt battery. ([Click Here](#))
  3. Disconnect the fuel feed hose line at the bulkhead.

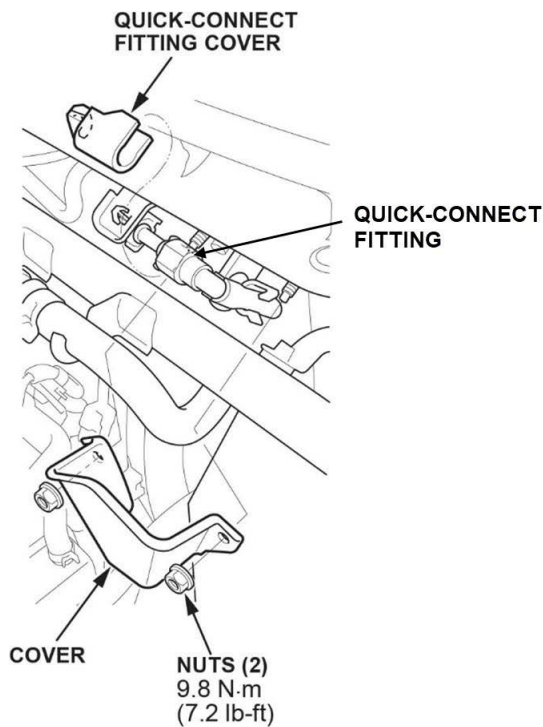

6. Remove the radiator cap.
7. Raise the vehicle.

8. Remove the front splash shield.

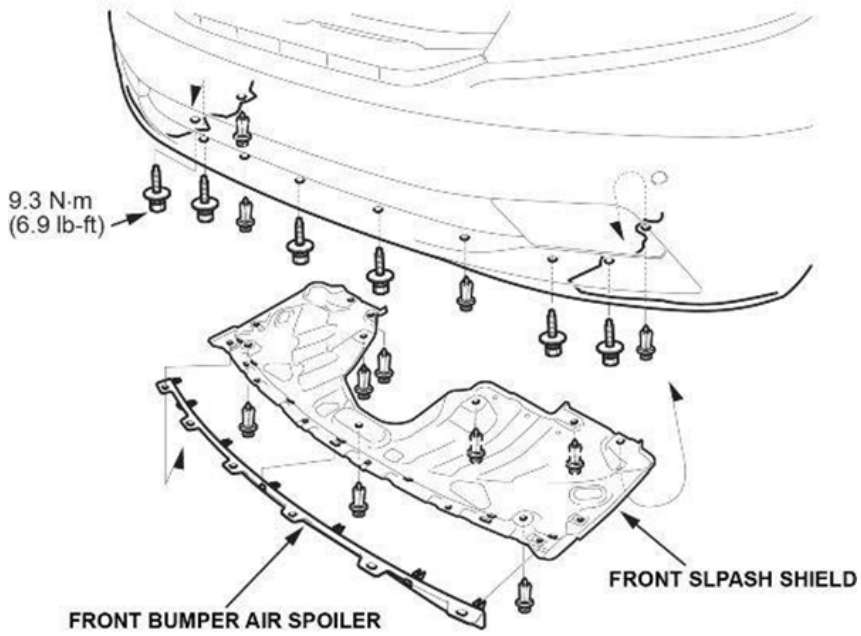

9. Drain the engine oil.

10. Loosen the drain plug on the radiator and drain the coolant.

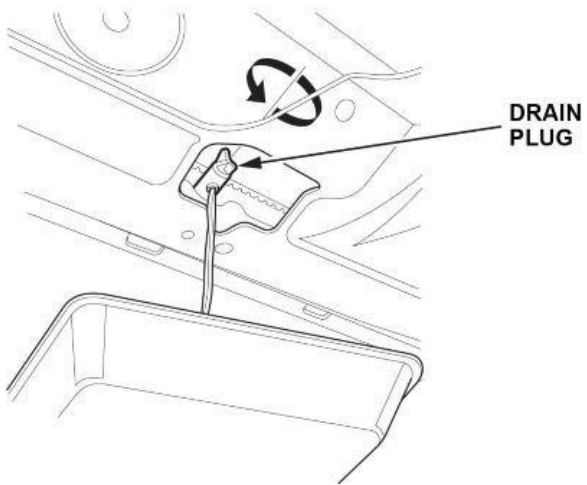

11. Drain the remaining coolant from the engine by installing a 5/16in. inner diameter rubber hose (commercially available) onto the block drain bolt located at the rear of the engine block, then loosen the drain bolt. Then disconnect the oil pressure switch connector.

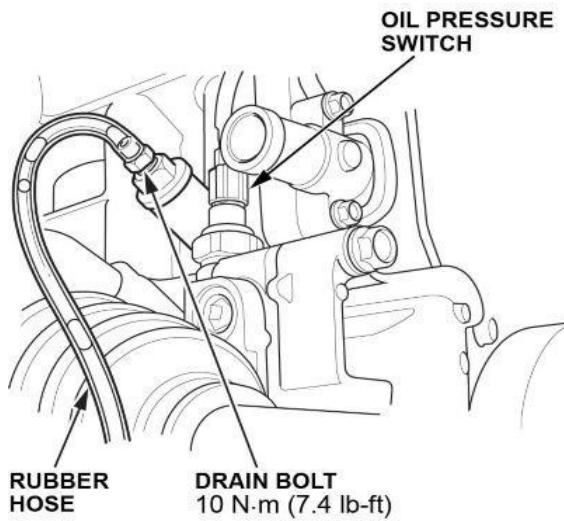

12. Remove exhaust pipe A, with under-floor TWC still attached. ([Click Here](#))
13. Depending on the diagnosis, remove the appropriate WU-TWC support bracket bolts. ([Click Here](#))
14. Remove the EGR lower pipe nuts (A).

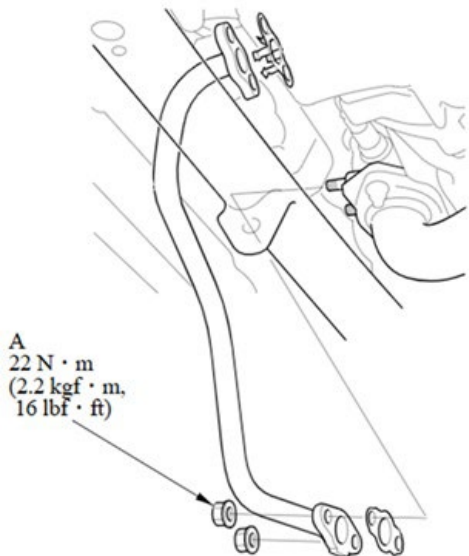

15. Remove the right fender liner.
16. Lower the vehicle.

17. Disconnect the MAP sensor connector and the breather pipe, then remove the intake air duct.

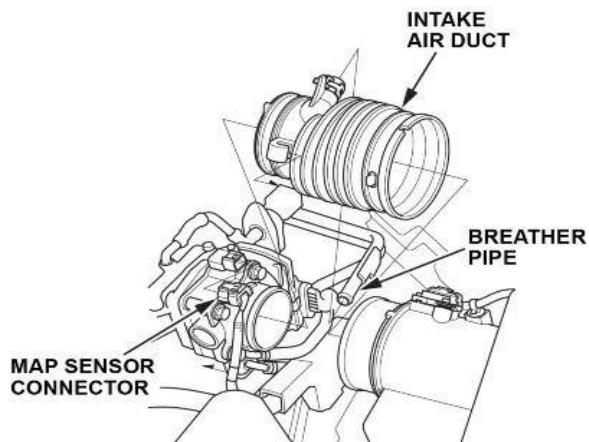

18. Disconnect the PCV hose (A), the brake booster vacuum hose (B), and the IMT actuator connector (C).

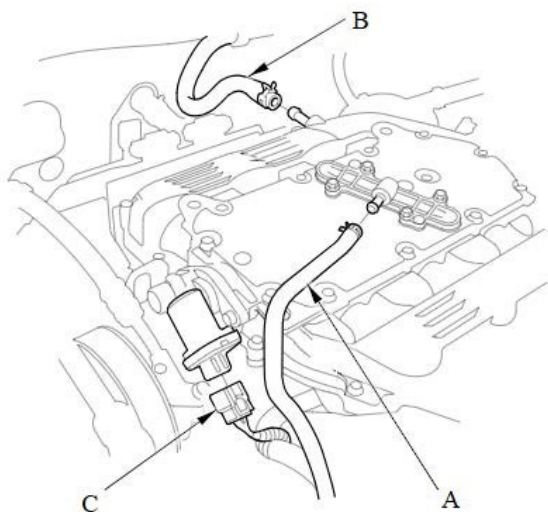

19. Disconnect the EVAP canister hose (A), the EVAP canister purge valve connector (B), the throttle actuator connector (C), and the MAP sensor connector (D). Disconnect and plug the water bypass hoses (E).

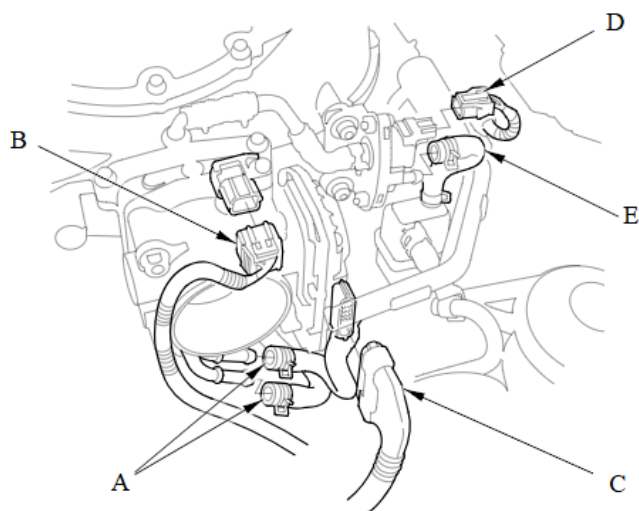

20. Lift the power steering reservoir out of the bracket and remove the drive belt. [\(Click Here\)](#)

21. Remove the alternator. [\(Click Here\)](#)

22. Remove the following. Do steps 6 and 7. [\(Click Here\)](#):

- Engine intake upper cover and PCV hose
- Remove the intake manifold bolts and nuts in **three steps**, then remove the intake manifold.

**FOR INSTALLATION:**

Install the intake manifold with a new intake manifold gasket. Tighten the bolts and nuts to **22 N·m (16 lb-ft)** in three steps in the sequence shown.

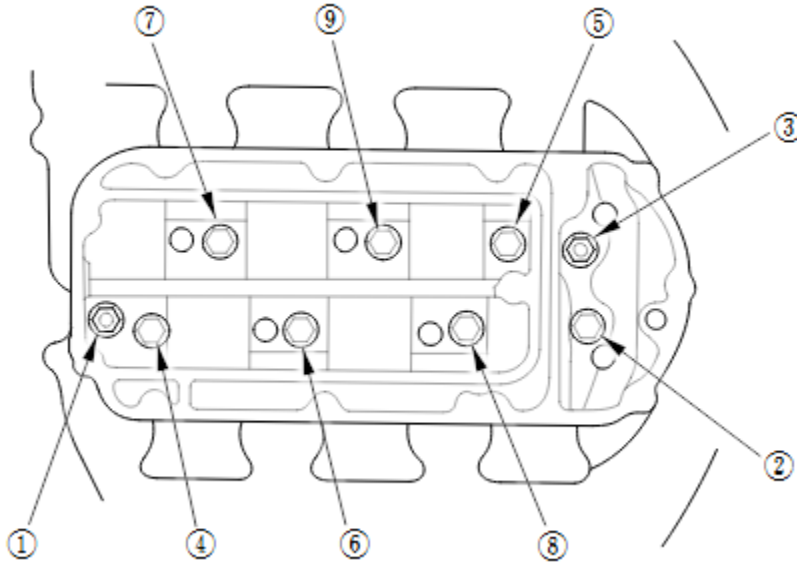

**FOR INSTALLATION:**

Install the upper cover (A) with a new gasket. Tighten the bolts and nuts to **12 N·m (8.9 lb-ft)** in three steps in the sequence shown below.

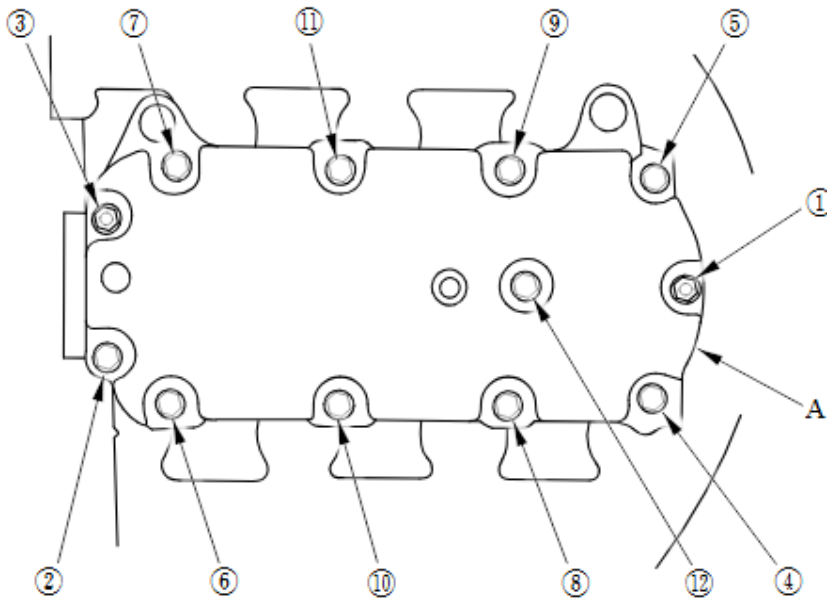

23. Remove the power steering pump bolts, the power steering hose bracket then secure the power steering pump out of the way.

NOTE: **DO NOT** remove any of the power steering hoses.

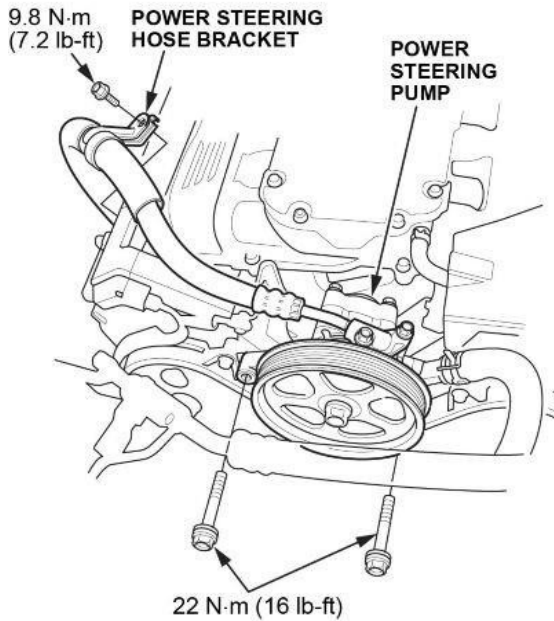

24. Remove the drive belt auto-tensioner. [\(Click Here\)](#)

25. Set the number 1 cylinder to TDC.

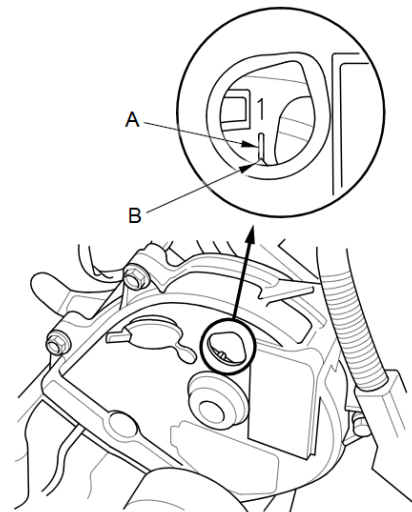
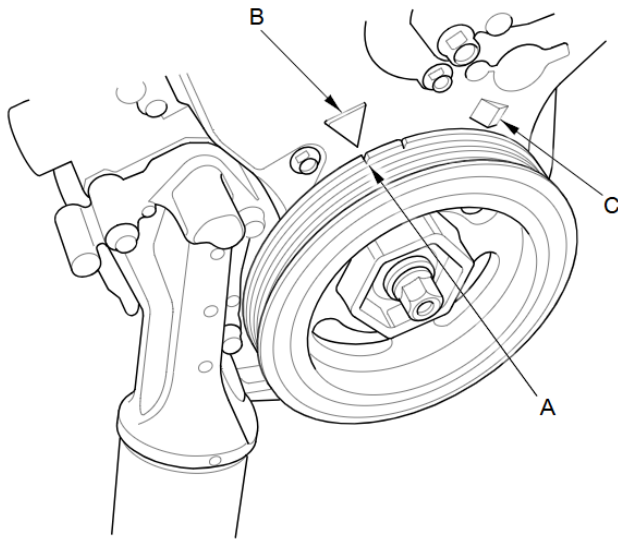

26. Remove the crankshaft pulley. Do steps 5 and 6. [\(Click Here\)](#)

27. Remove the PCM cover.

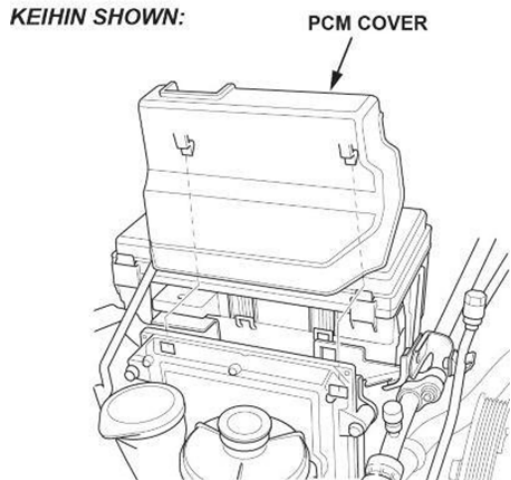

28. Remove the harness clamps (A), then disconnect the PCM connectors (B), and the engine wire harness connector (C), then remove the PCM with the bracket.

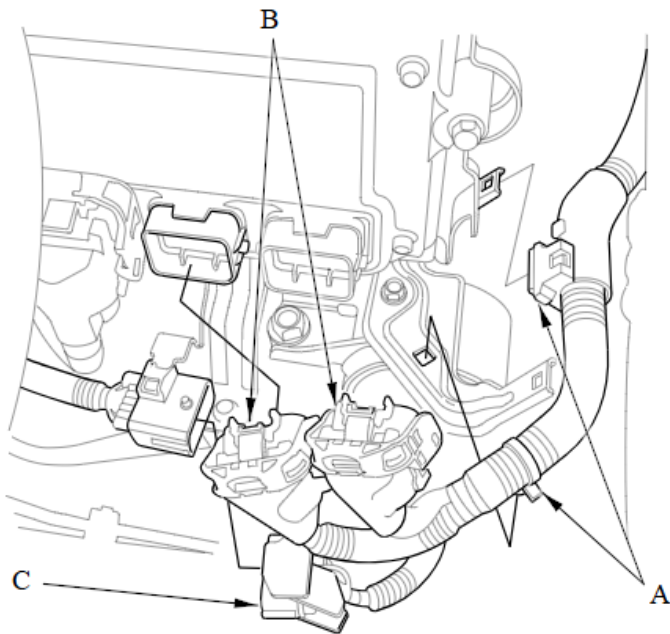

29. Remove the ground cable bracket (A), then remove the upper side engine mount bracket (B).

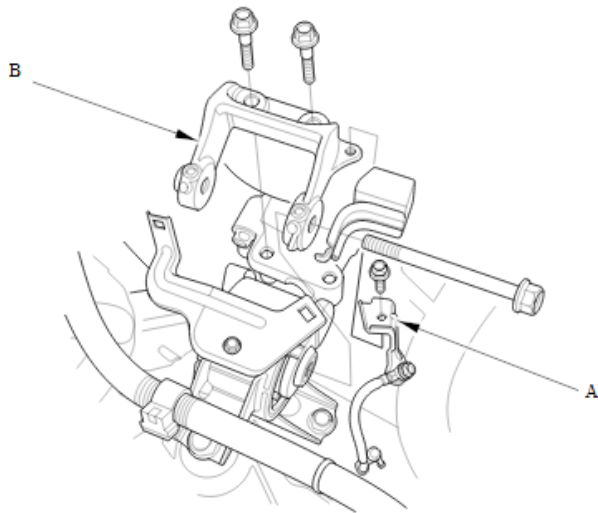

30. Remove the front upper timing cover (A) and the rear upper timing cover (B).

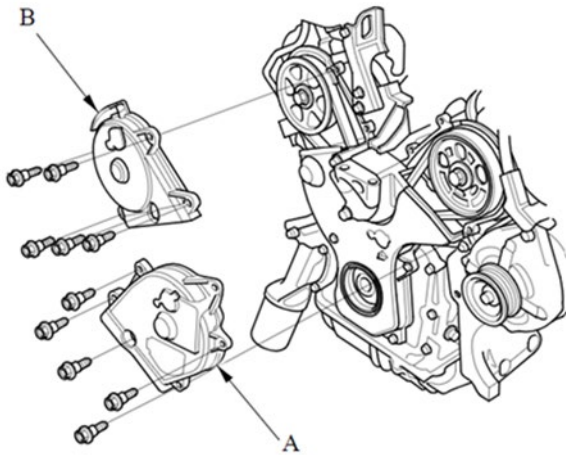

31. Raise the vehicle.

32. Remove the lower timing cover.

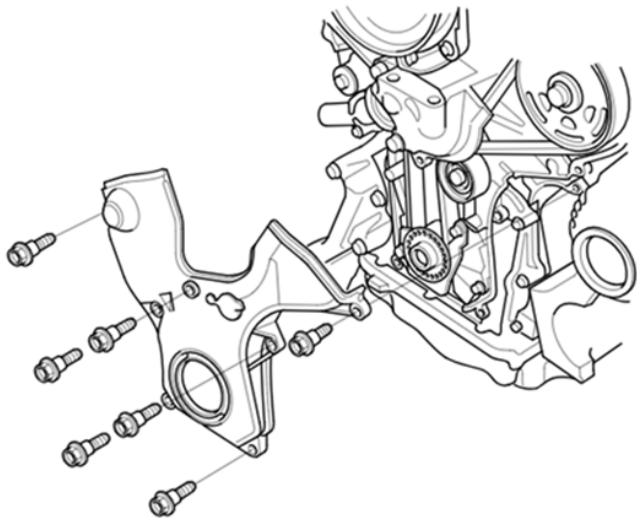

33. Lower the vehicle.

34. Remove the lower half of the side engine mount bracket.

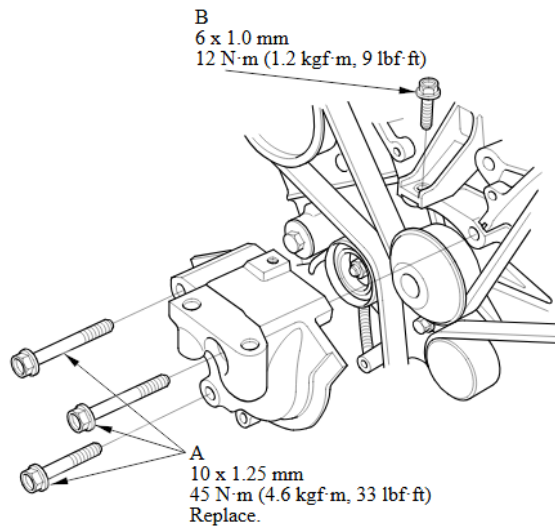

35. Remove the timing belt auto-tensioner.

NOTE: See the service information procedure to compress the tensioner for installation.

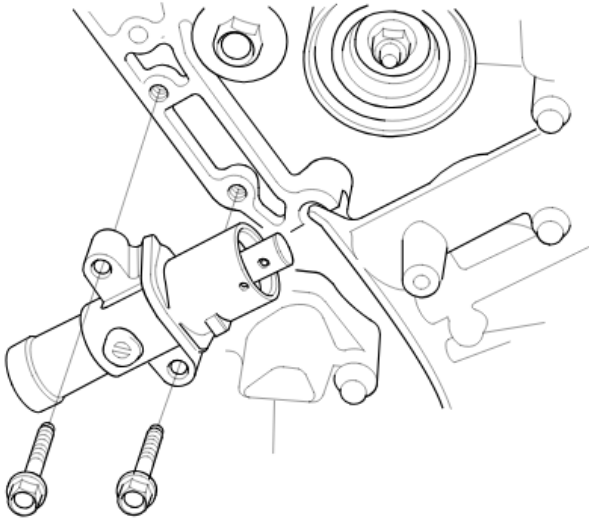

36. Remove the timing belt. ([Click Here](#))

37. Depending on the diagnosis, remove some or all of the following parts that are necessary:

- ECT sensor 1 connector
- Front rocker arm oil pressure switch connector
- Rear rocker arm oil pressure switch connector
- CMP sensor connector
- Front A/F sensor 1 connector
- Rear A/F sensor 1 connector
- Front secondary HO2S connector
- Rear secondary HO2S connector
- Rocker arm oil control solenoid A connector (bank one)
- Rocker arm oil control solenoid A connector (bank two)
- Rocker arm oil control solenoid B connector (bank one)
- Knock sensor connector

38. Remove the quick-connect fitting cover, then disconnect the fuel feed hose.

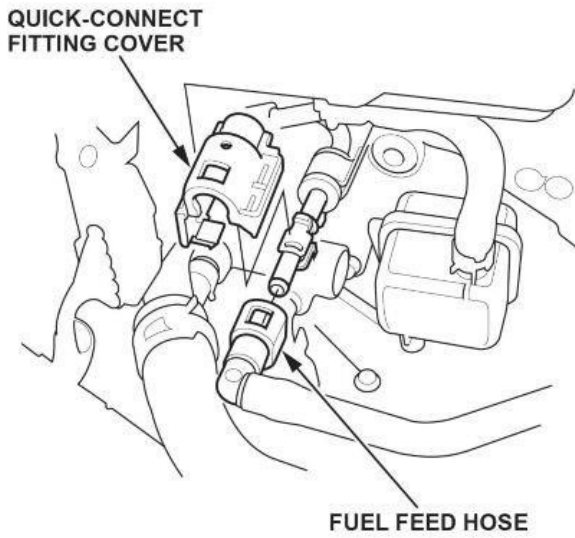

39. Remove the EVAP canister purge joint with the bracket.

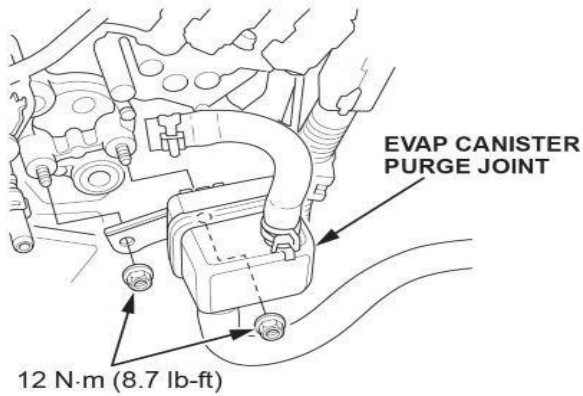

40. Remove the fuel rail connecting joint hose.

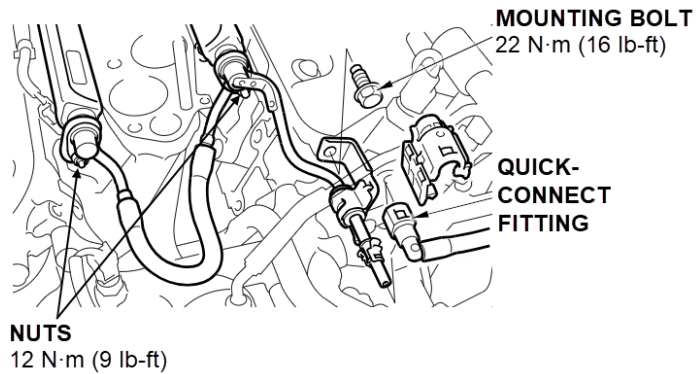

41. Remove the upper EGR pipe mounting bolts, then remove the EGR pipe.

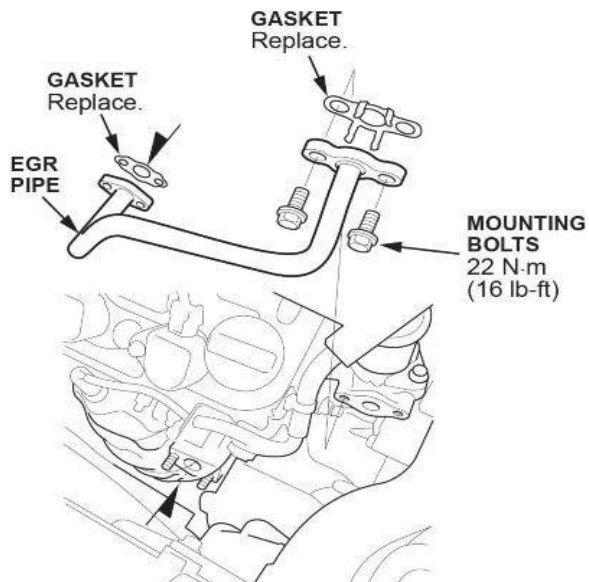

42. Remove upper and lower radiator coolant hoses.

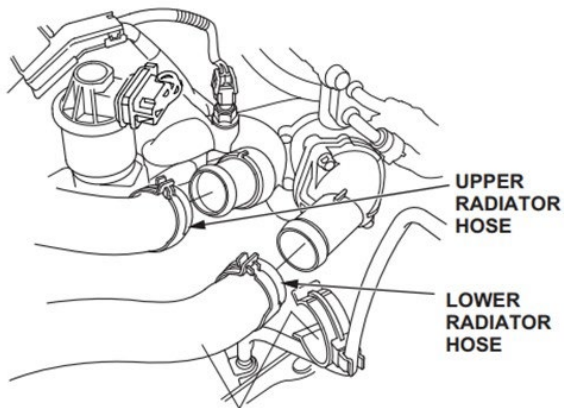

43. Separate the water passage from the cylinder heads, then remove the water passage assembly.

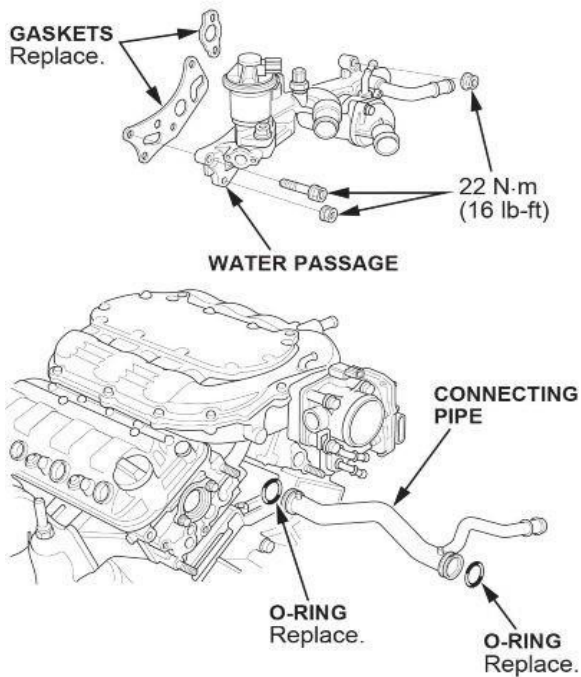

44. Remove the starter by removing the harness clamp (A), then disconnect the positive starter cable (B) and the S terminal connector (C) from the starter. Remove the lower radiator hose bracket (D) and the dipstick (E), then remove the starter assembly (F).

NOTE: Install with a new gasket (G).

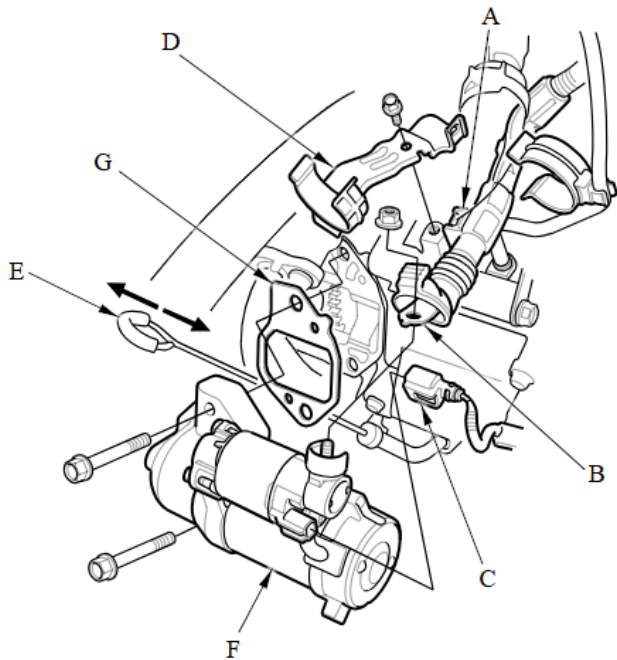

45. Remove the appropriate WU-TWC depending on diagnosis and set the WU-TWC aside.

NOTE: The WU-TWC can be set aside. Cover the opening with a shop towel to prevent coolant from entering.

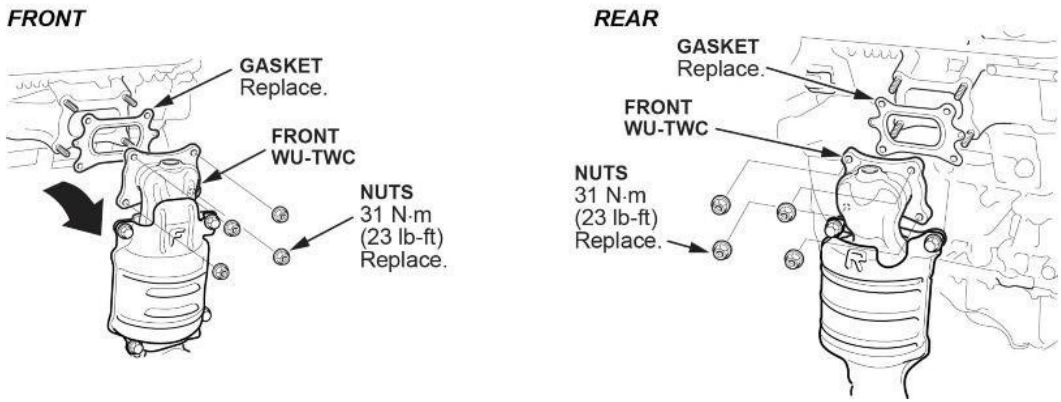

46. Remove the appropriate head with the injector base attached.

NOTE:

- Depending on the diagnosis, you will remove the rear bank cylinder head or both cylinder heads.
- To prevent warpage, loosen the bolts in sequence, 1/3 turn at a time, repeat until all the bolts are loosened.

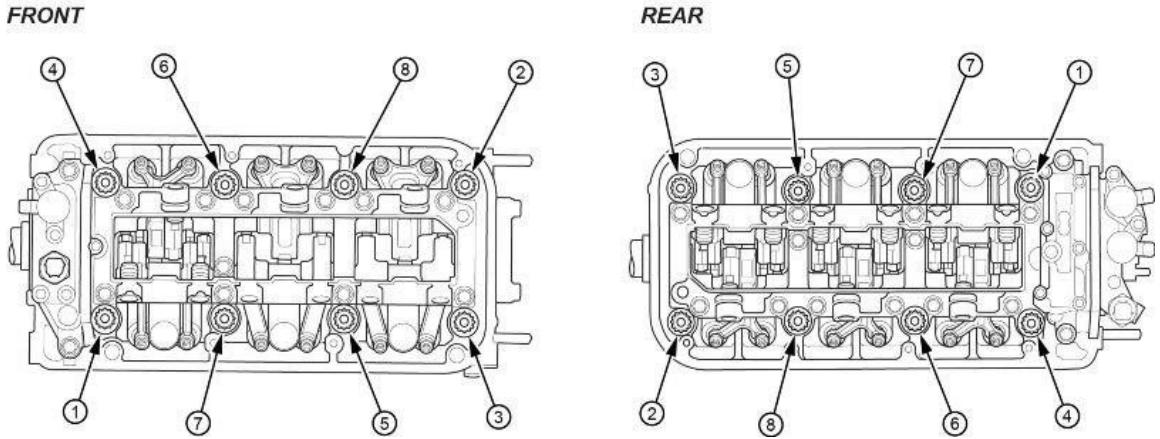

47. Measure the head bolts to determine if they need replacement. If either diameter is less than **11.3 mm (0.445 in.)**, replace the cylinder head bolts before reassembly.

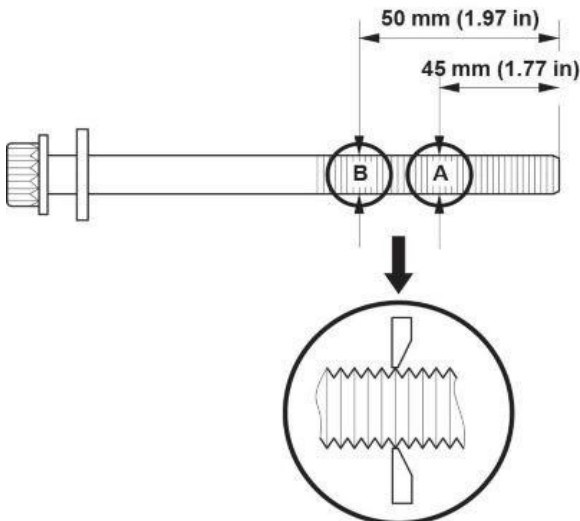

48. Use the cylinder wall inspection tool to inspect the cylinder walls for vertical scratching.

NOTE:

- For information on using the cylinder wall inspection tool, refer to the Job Aid “Cylinder Wall Inspection Tool” and/or *Tech2Tech* “Check out the Cylinder Wall Inspection Tool”.
- Do not use a fingernail or pencil lead to determine if an engine block is usable. Light to moderate scratches that are detected with your fingernail will pass the inspection when using the cylinder wall inspection tool.

[Check Out the Cylinder Wall Inspection Tool](#)

**Special tool (07AAJ-R70A301)**



Determine the repair direction based on the cylinder inspection:

DTCs Stored	Cylinder Bore Condition?	Repair Direction
P0301, P0302, or P0303	No scratching detected	<b>Do Repair Procedure A:</b> <ul style="list-style-type: none"> <li>• Clean pistons 1-3</li> <li>• Replace piston rings 1-3</li> <li>• Replace spark plugs 1-4</li> <li>• Update PCM software</li> </ul>
	Scratching detected	<b>Do <a href="#">Repair Procedure B</a>:</b> <ul style="list-style-type: none"> <li>• Remove front cylinder head (follow the steps above to remove the front cylinder head, then proceed to Repair Procedure B)</li> <li>• Replace short block</li> <li>• Replace spark plugs 1-4</li> <li>• Update PCM software</li> </ul>
P0304	No scratching detected	<b>Do Repair Procedure A:</b> <ul style="list-style-type: none"> <li>• Clean pistons 1-4</li> <li>• Replace piston rings 1-4</li> <li>• Replace spark plugs 1-4</li> <li>• Update PCM software</li> </ul>
	Scratching detected	<b>Do <a href="#">Repair Procedure B</a>:</b> <ul style="list-style-type: none"> <li>• Replace short block</li> <li>• Replace spark plugs 1-4</li> <li>• Update PCM software</li> </ul>

## REPAIR PROCEDURE A

### Piston Removal, Cleaning, and Ring Replacement

1. Raise the vehicle.
2. Remove the CKP sensor cover and bolts, then disconnect the CKP sensor connector.

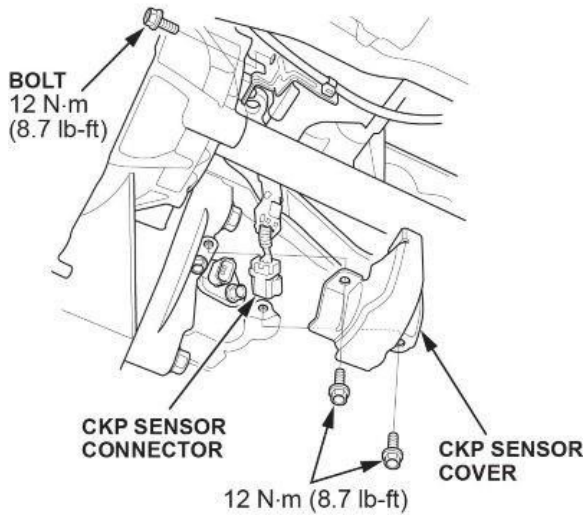

3. Remove the torque converter case cover and the four bolts securing the oil pan to the transmission.

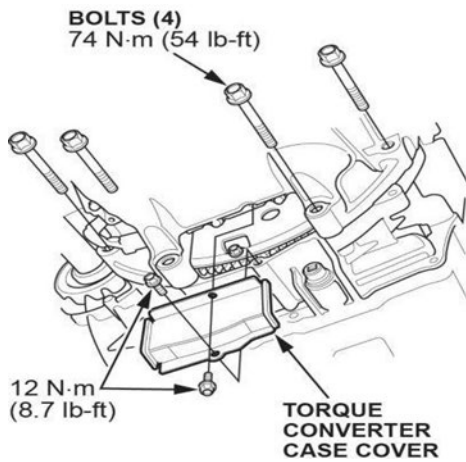

4. Remove all bolts securing the oil pan.

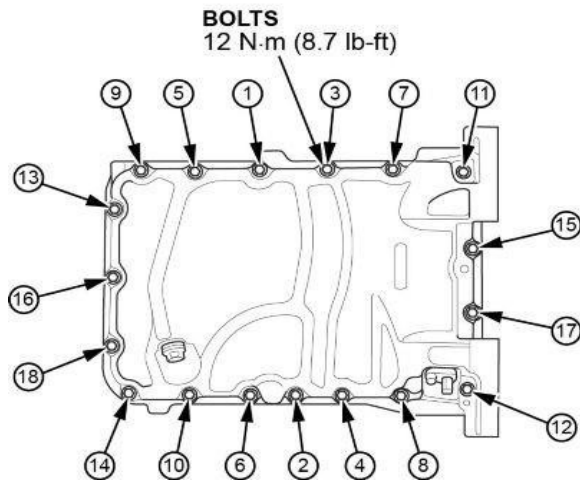

5. Using a flat blade screwdriver, separate the oil pan from the engine block in the areas shown.

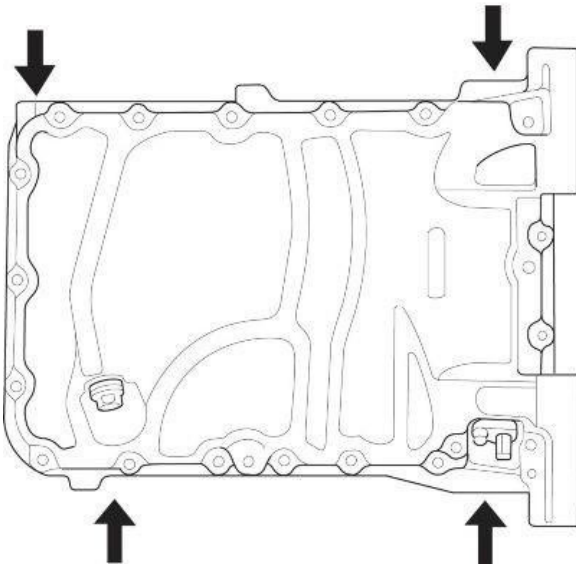

6. Remove the oil strainer and baffle plate.

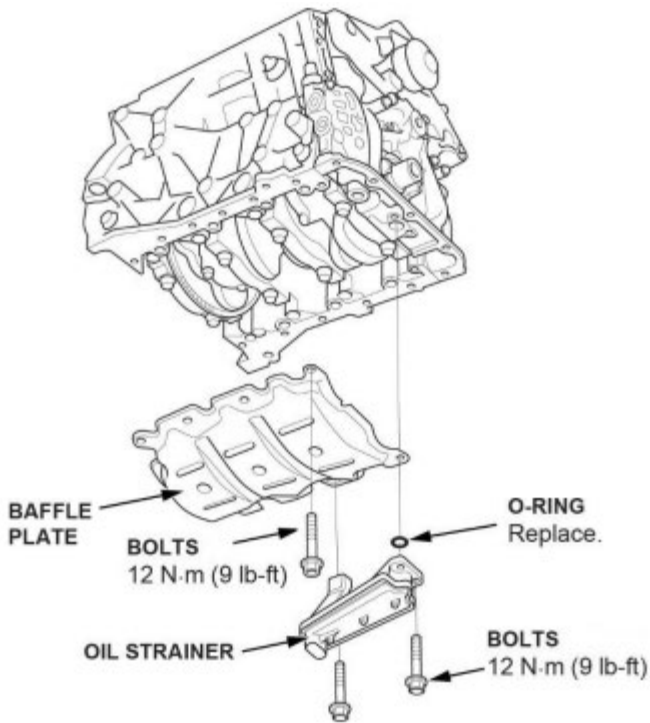

7. Remove the appropriate piston depending on diagnosis.

NOTE:

- **Before** removing the rod caps, use a grease pencil or suitable marking pen to mark each cap and its corresponding connecting rod with the cylinder number it came from.
- Do not confuse the existing marking on the side of the connecting rod and rod cap with a cylinder number. They are just manufacturing marks referring to the size of the big end of the rod.
- **Installing a rod cap incorrectly will result in engine knock and/or engine failure. Remove and mark one rod assembly at a time to make sure it is assembled correctly.**
- When torquing the rod cap bolts, refer to the service information for details.

Click [HERE](#) to go to the Tech2Tech® video "[Tips When Working with Fracture Rods](#)".

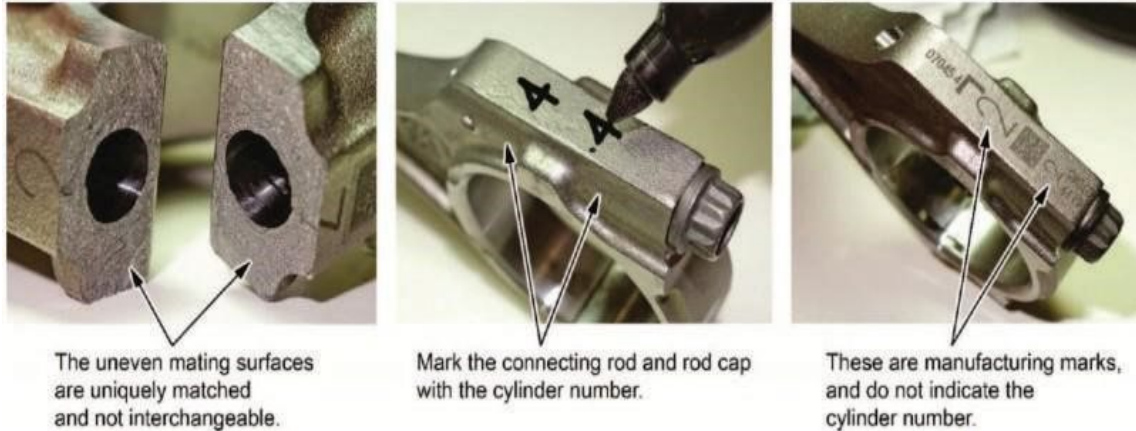

### Piston Cleaning and Ring Replacement

1. Remove the piston rings from the piston using a ring expander. Be careful not to damage the piston.

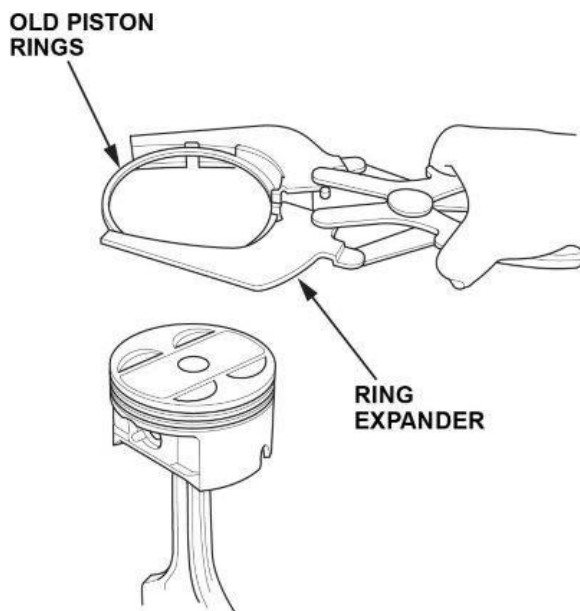

2. Spray the piston head and piston ring grooves thoroughly with Honda throttle plate cleaner.

3. While holding the piston upright in your left hand, take the piston ring groove cleaner tool in your right hand and line up the cleaner tool guides with the second (middle) piston ring groove.



4. Press the handle on the piston ring groove cleaner tool and slide the cleaning bit onto the appropriate piston ring grooves.



5. Once the cleaning bit is in the appropriate ring grooves of the piston, make sure the tool handle clicks into place.  
NOTE: There is only one notch on the tool for the handle to engage.

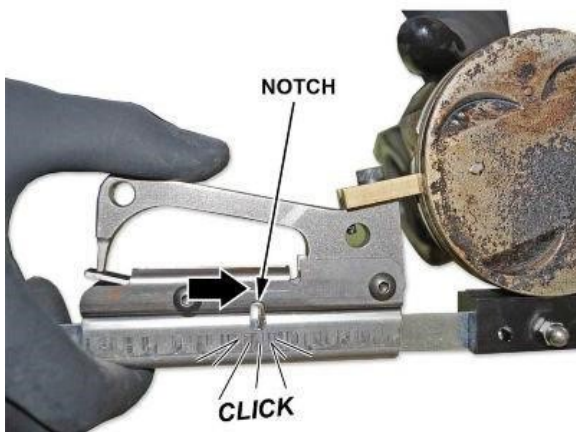

6. Hold the piston steady and rotate the tool counter-clockwise five to six times to remove any carbon deposits in the piston ring grooves. **Do not** rotate the tool clockwise.

NOTE: You can watch this procedure in the Tech2Tech segment [“How to Clean Piston Ring Grooves”](#).



7. Remove the piston groove cleaning tool and clean off the carbon from the tool bit.
8. Finish cleaning the piston with throttle plate cleaner and the nylon brush. Do not use a steel wire brush.



NOTE: Below are some examples of before and after pictures. Depending on mileage and running conditions, the pistons will achieve different levels of cleanliness.

**54K PISTON**



**87K PISTON**



9. Install the piston rings as shown.

NOTE: The first (top) ring has a **1R** manufacturing mark and the second (middle) ring has an **SPR** manufacturing mark. The manufacturing marks **must** face upward.

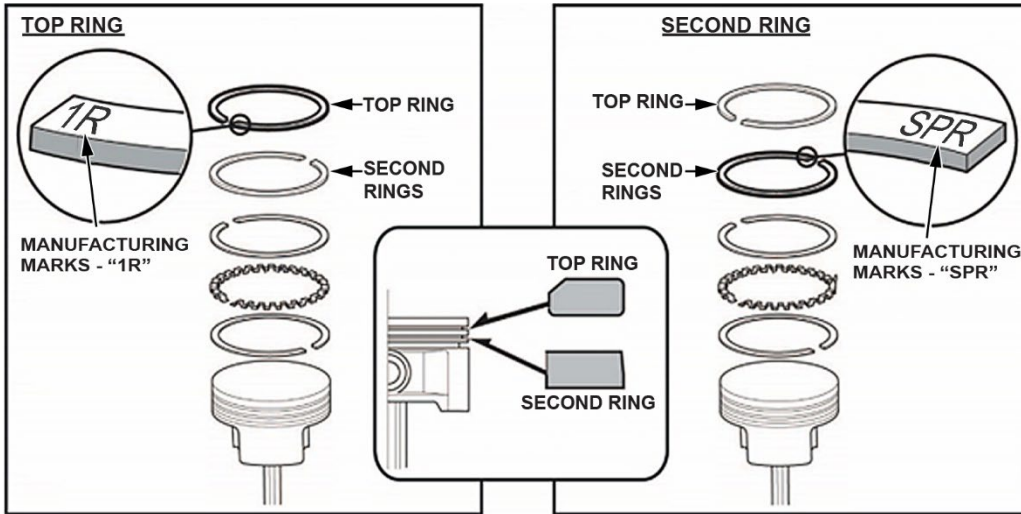

10. Rotate the rings in their grooves, make sure the rings do not bind.

11. Position the ring end gaps as shown.

NOTE: If the ring gaps are not positioned correctly, excessive blowby may occur.

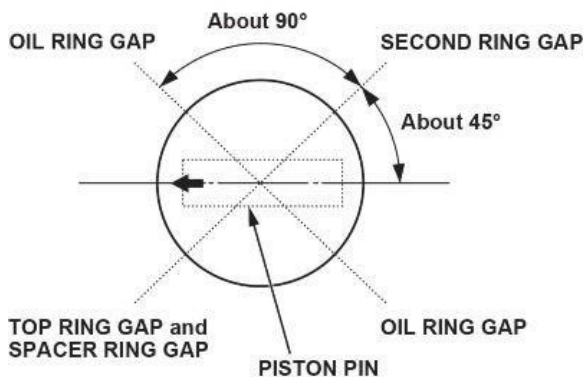

12. Apply new engine oil to the piston, the inside of the piston ring compressor, and the cylinder bore.

NOTE: **Cylinder wall honing is NOT required for this repair.**

13. Install the piston/connecting rod assembly into the cylinder bore with the arrow on top of the piston facing the timing belt side of the engine.

NOTE: Be careful not to damage the cylinder wall when installing the piston.

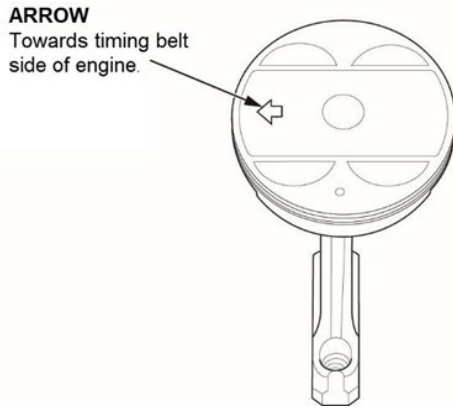

14. Set the piston in the ring compressor and position the piston in the cylinder based on the rod/cap marks that were made during disassembly.

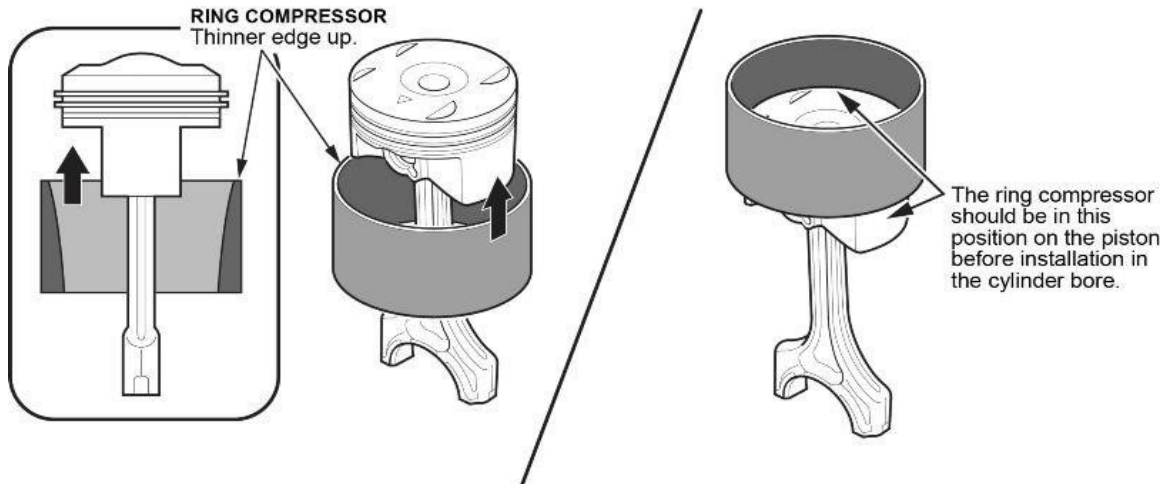

15. Set the ring compressor on the piston bore, then push the piston in with your hands.

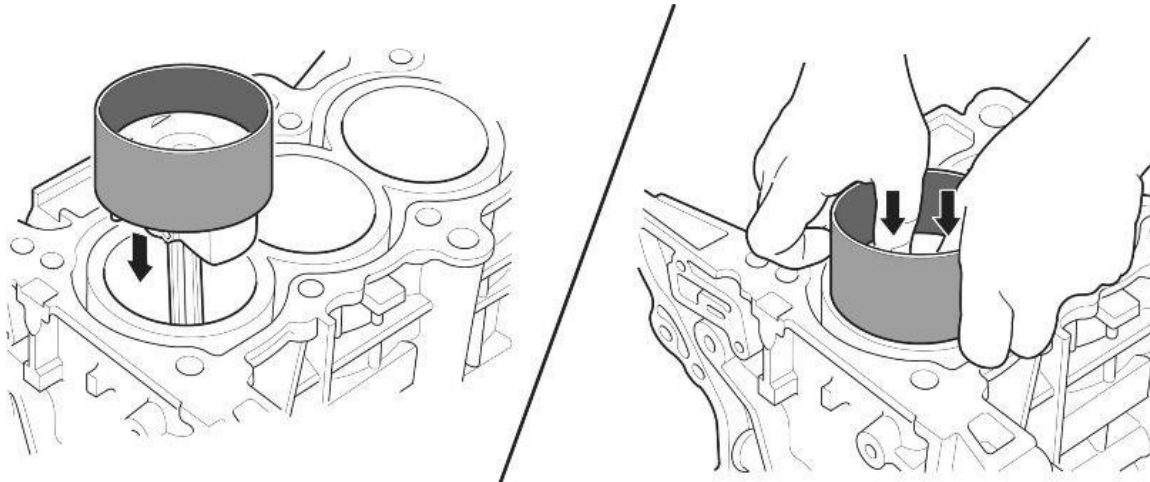

16. Stop after the ring compressor pops free and check the connecting rod-to-rod journal alignment before pushing the piston into place.

17. Measure the diameter of the connecting rod bolts to determine if they need replacement. Calculate the difference in diameter between point A and point B. It should not be more than **0–0.1 mm (0–0.004 in)**. Any bolts exceeding specification should be replaced.

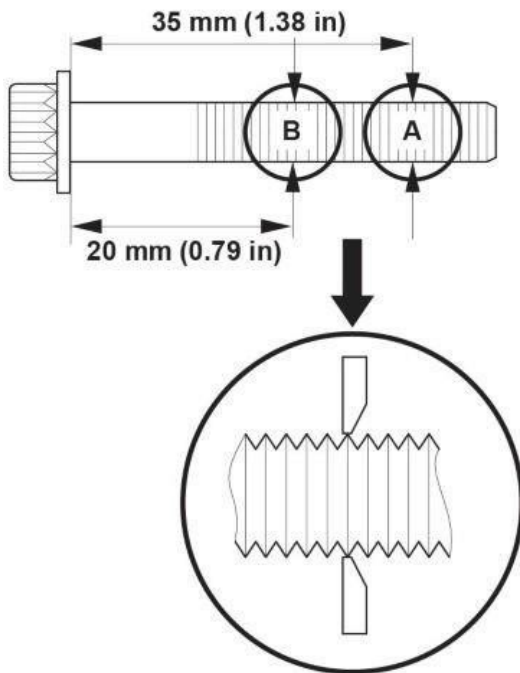

18. Install the connecting rod cap and bearing by applying new oil to the connecting rod bolt threads and flanges. Torque the bolts to **20 N·m (14 lb-ft)** then tighten the connecting rod bolts an additional quarter turn (**90 degrees**).

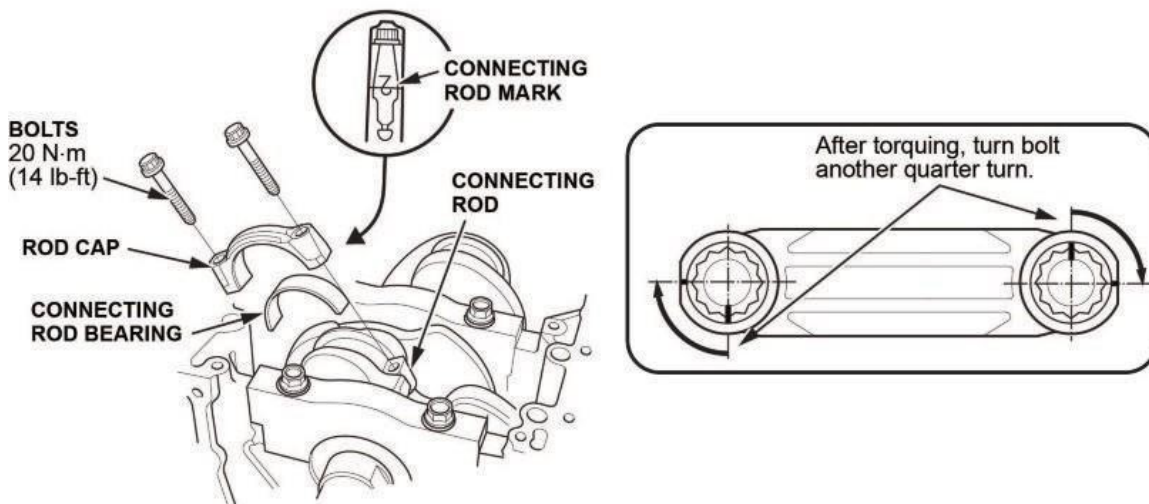

19. Install the baffle plate, then install the oil strainer with a new O-ring..

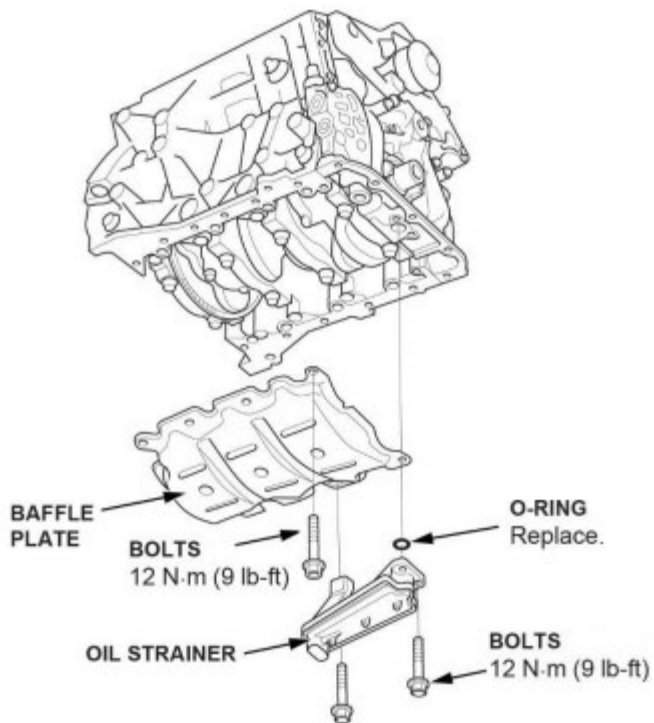

20. Install the oil pan and tighten the bolts in 3 steps. In the final step, tighten all bolts in sequence to **12 N·m (8.9 lb-ft)**.

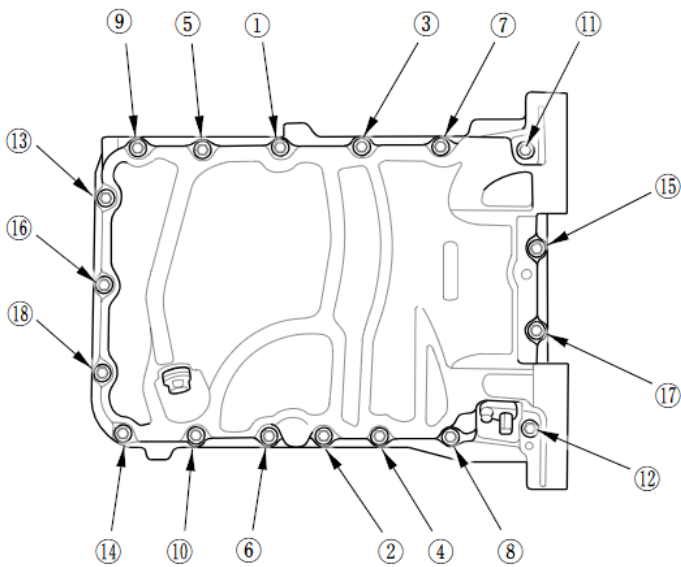

21. Lower the vehicle.

22. Install the cylinder head(s).

NOTE: The crankshaft and camshafts should be set to TDC.

Steps for torquing the cylinder head bolts to specification:

1. Apply new engine oil to the threads and under the bolt heads.
2. Torque the cylinder bolts in sequence to **29 N·m (22 lb-ft)**.
3. Tighten in sequence an additional **90 degrees** (third step).
4. Tighten in sequence an additional **90 degrees** (fourth step).
5. If the bolts are new, tighten an additional 90 degrees.

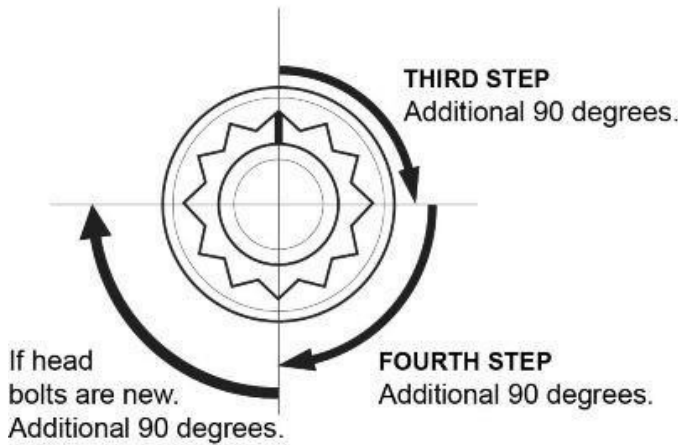

**Cylinder Head Bolt Installation Sequence**

FRONT

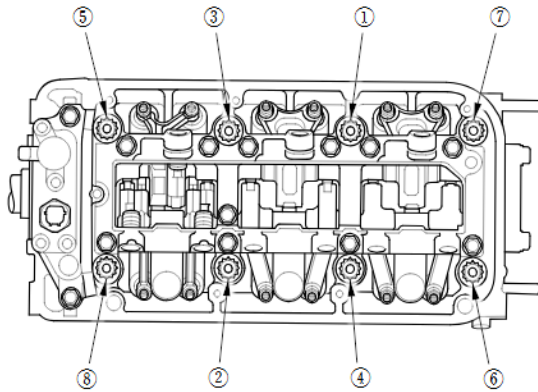

REAR

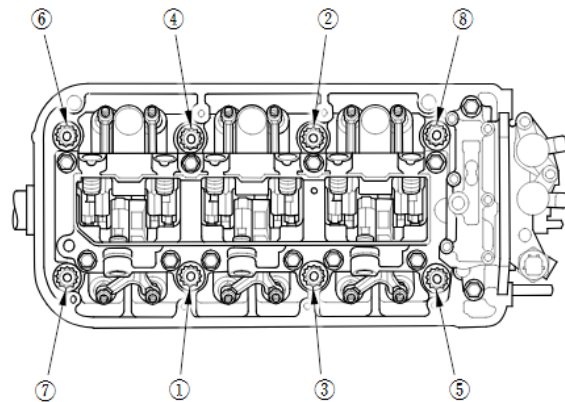

23. Install the catalytic converter(s). Torque the nuts to their specified torque.

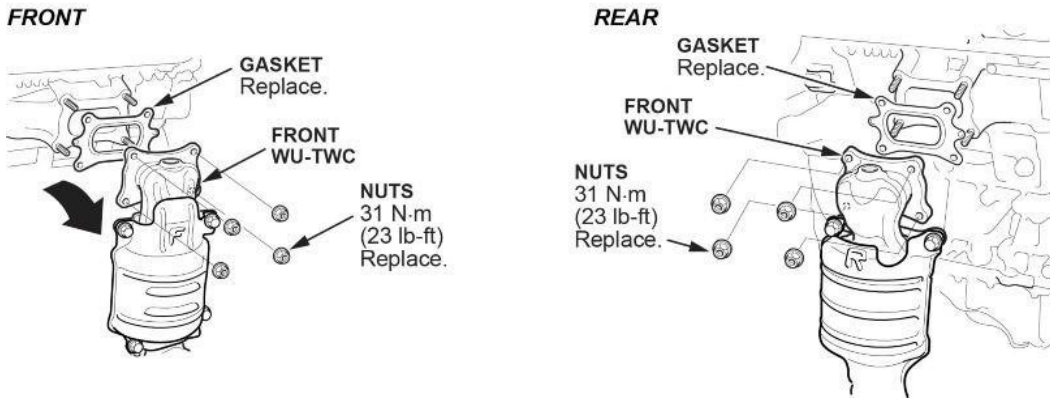

24. Install the timing belt, covers and crank pulley. ([Click Here](#))

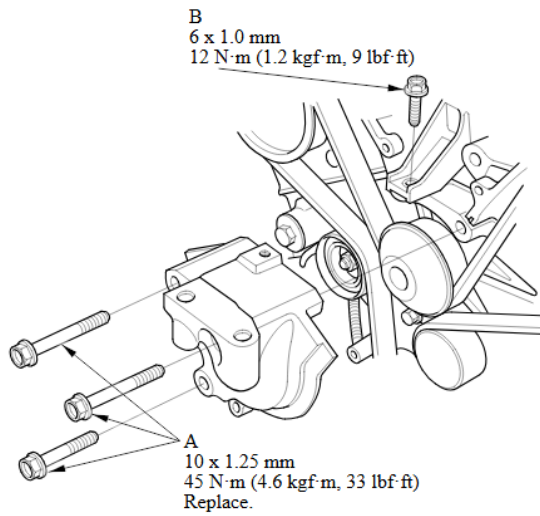

25. Install the timing belt auto-tensioner.

NOTE: Refer to the service manual for the procedure to compress the timing belt auto-tensioner before installation.

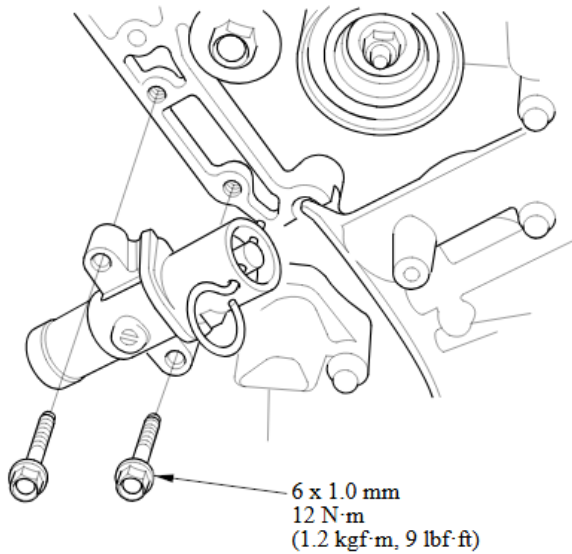

26. [Perform valve clearance check and adjust.](#)
27. Replace spark plugs 1–4.
28. Raise the vehicle.
29. Install exhaust pipe A (A) with new gaskets (B) and nuts.

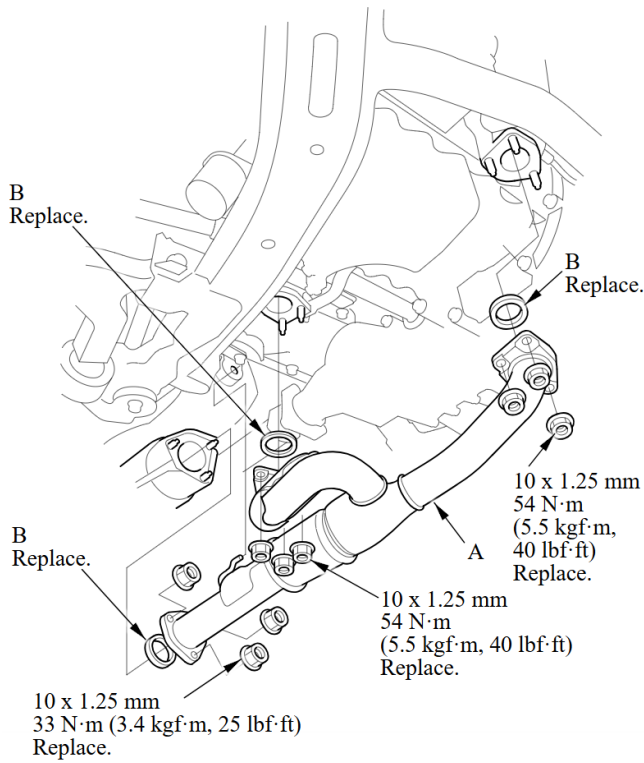

30. Reinstall the remaining components in reverse order of removal.
31. Install a new oil filter and refill the engine with engine oil.  
**At Oil Change: 4.0 L (4.2 US qt)**  
**At Oil Change including Filter:4.3 L (4.5 US qt)**  
**After Engine Overhaul: 5.0 L (5.3 US qt)**
32. Move the shift lever to each gear and verify that the A/T gear position indicator follows the transmission range switch.
33. Refill the radiator with engine coolant.
34. Inspect for fuel leaks. Turn the ignition switch to ON (II) (do not operate the starter) so the fuel pump runs for about 2 seconds and pressurizes the fuel line. Repeat this operation three times, then check for fuel leakage at any point in the fuel line.
35. Check the PCM software version P/N located above the PGM-FI Data List.

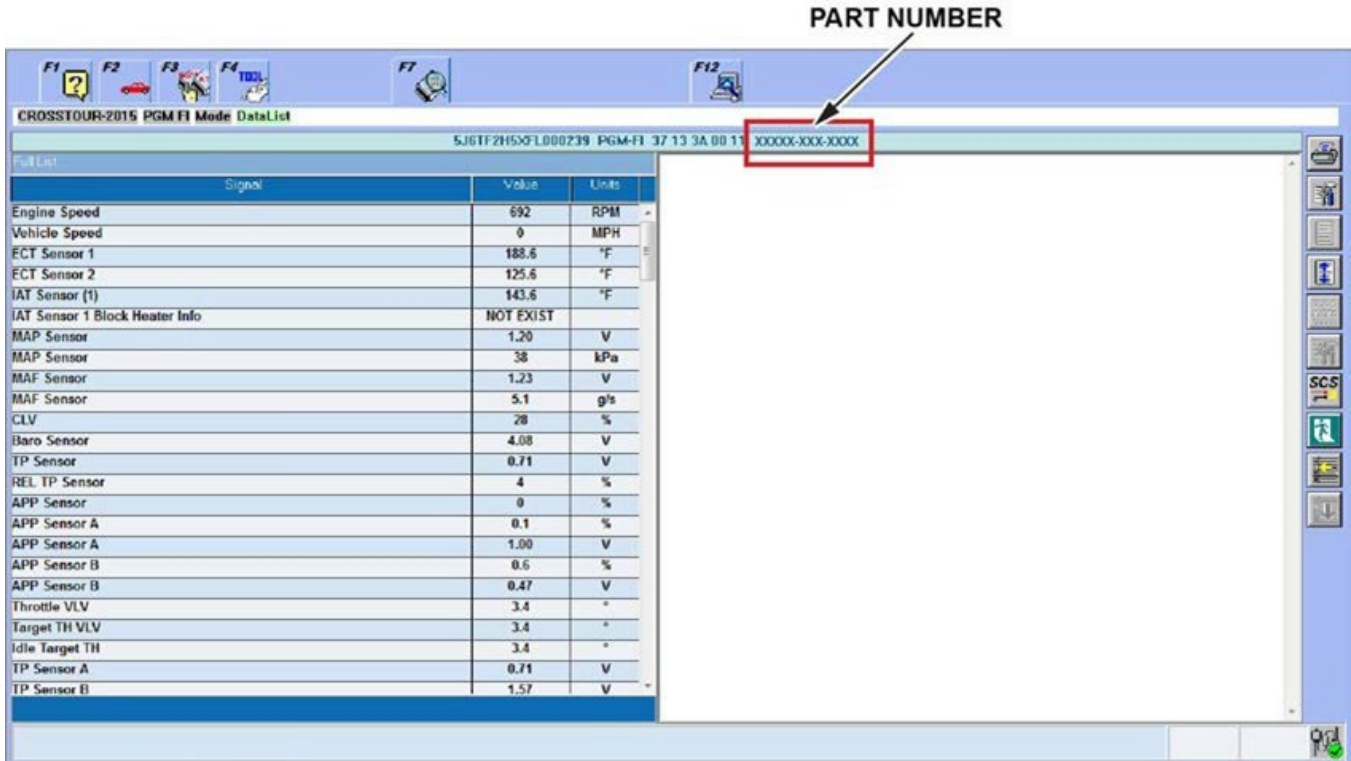

Year	Model	Program ID
2013	Odyssey	37805-RV0-C010 (5AT) 37805-RV0-C110 (6AT)
2014–16	Odyssey	37805-RV0-A660
2017	Odyssey	37805-RV0-A020

37. Do the PCM update, if needed.  
NOTE: For information on updating the PCM see service bulletin 22-100 Updating Control Units/Modules with the Honda ECU Reprogramming Application.

Is the PCM Program ID and/or Program P/N current than what is listed?

- **YES** – The correct software is installed
- **NO** – The PCM software needs to be updated

38. Do the [Idle Learn Procedure](#).

## REPAIR PROCEDURE B

### Engine Short Block Replacement

NOTE: Removed the front cylinder head, if applicable, follow the [INSPECTION PROCEDURE](#).

1. [Disconnect steering column at the joint.](#)

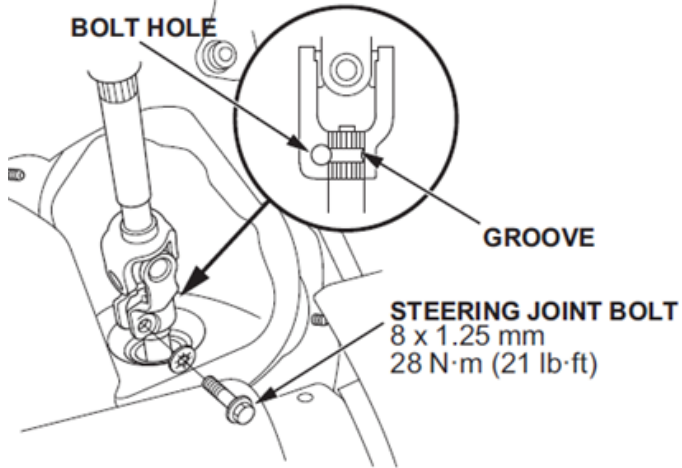

2. Disconnect the engine wire harness (A) and starter cable (B) from the main under-hood fuse box (C), then remove the main under-hood fuse box and the harness clamps (D).

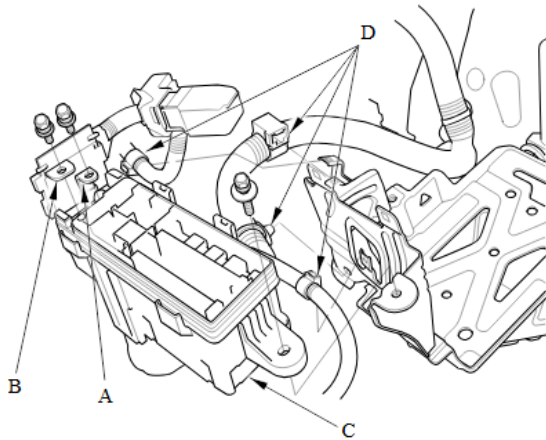

3. Remove the harness clamps (A) and the bolts (B) and loosen the bolt (C), then remove the battery base (D).

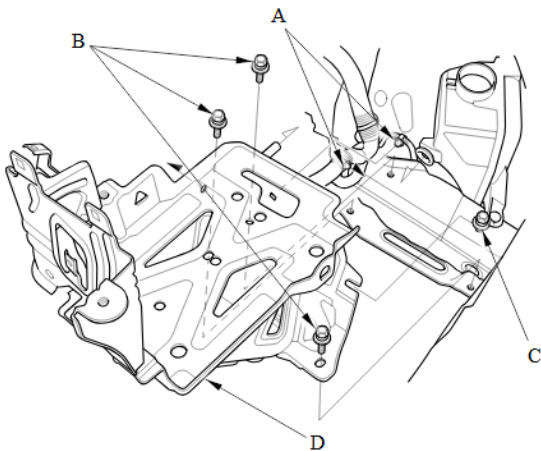

4. Remove coolant connecting pipe.

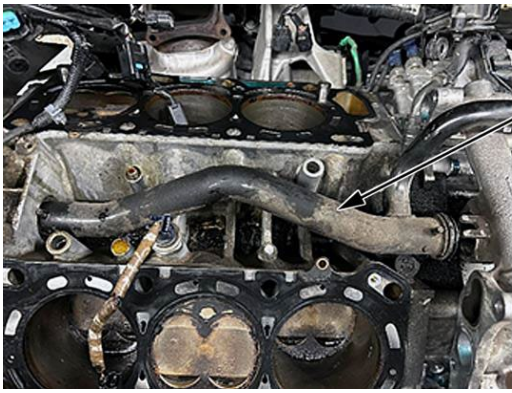

CONNECTING PIPE

5. [Disconnect transmission shift cable.](#)

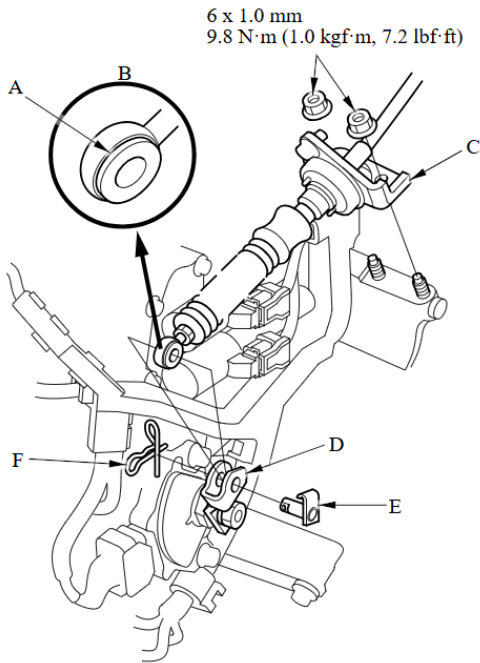

6. Disconnect the A/C compressor clutch connector (A), then remove the A/C compressor (B) without disconnecting the A/C hoses.

NOTE:

- **Do not** bend the A/C hoses excessively.
- Hang the A/C compressor with a wire tie.

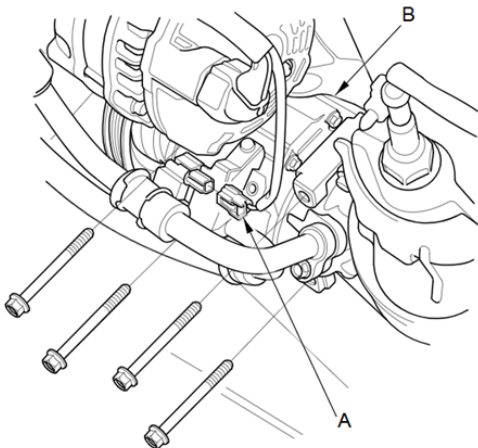

7. Remove the power steering fluid from the reservoir (A) to prevent fluid leaks.

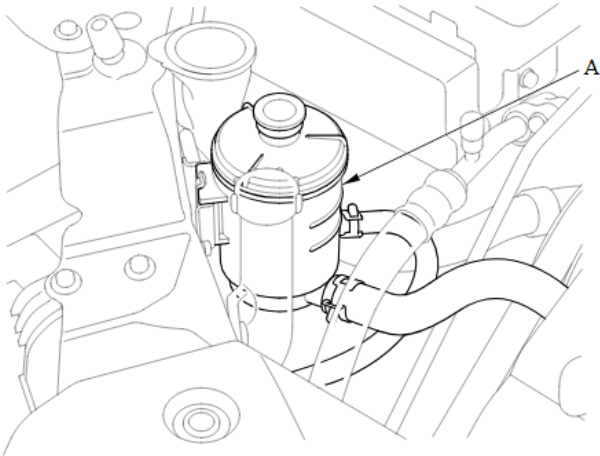

8. Disconnect the power steering pump inlet hose (A) and the power steering pump outlet hose (B) from the power steering pump, then plug the power steering hoses and the power steering pump. Remove the power steering hose bracket (C).

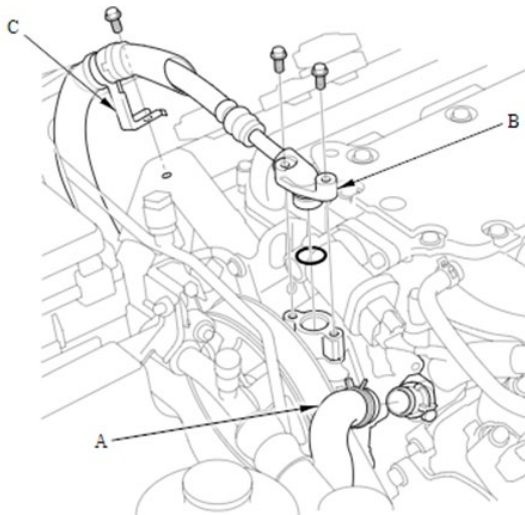

9. Lift the vehicle and drain the transmission fluid. [5-Speed AT](#), [6 Speed AT](#).

NOTE: Re-install the drain bolt with a new washer after draining the transmission fluid. Torque the drain bolt and washer to the specified torque **49 N·m (5.0 kgf·m, 36 lbf·ft)**.

10. Remove the left fender liner.  
11. Disconnect lower A/T cooler hoses. [5 Speed AT](#) [6 Speed AT](#)

12. Remove transmission ground bolt/cable (A).

(5AT)

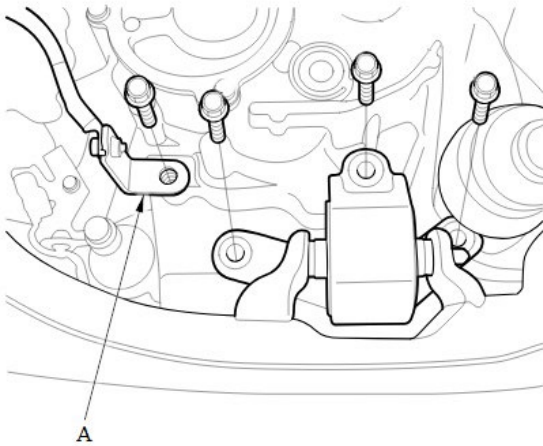

(6AT)

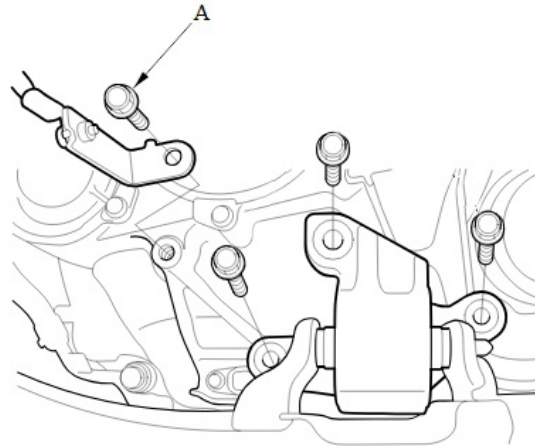

13. Remove damper pinch bolts and flange nuts, repeat for both sides.

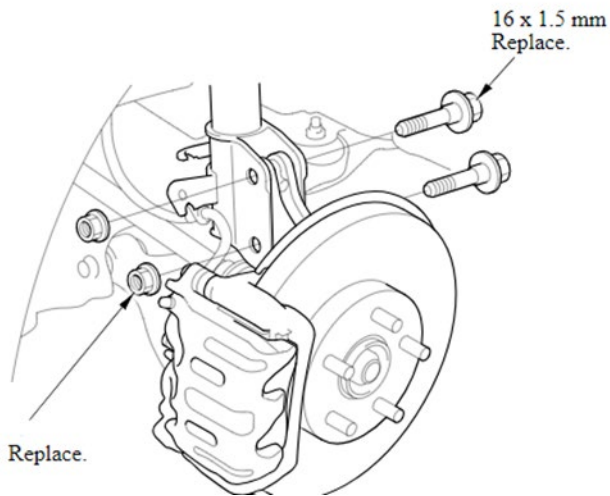

14. Remove the left side brake hose mounting bolt (A), then remove the caliper bracket mounting bolts (B) and remove the caliper (C) from the knuckle. Repeat the procedure for the right side.

NOTE: To prevent damage to the caliper assembly or brake hose, use a short piece of wire to hang the caliper assembly from the undercarriage. **Do not** twist the brake hose excessively.

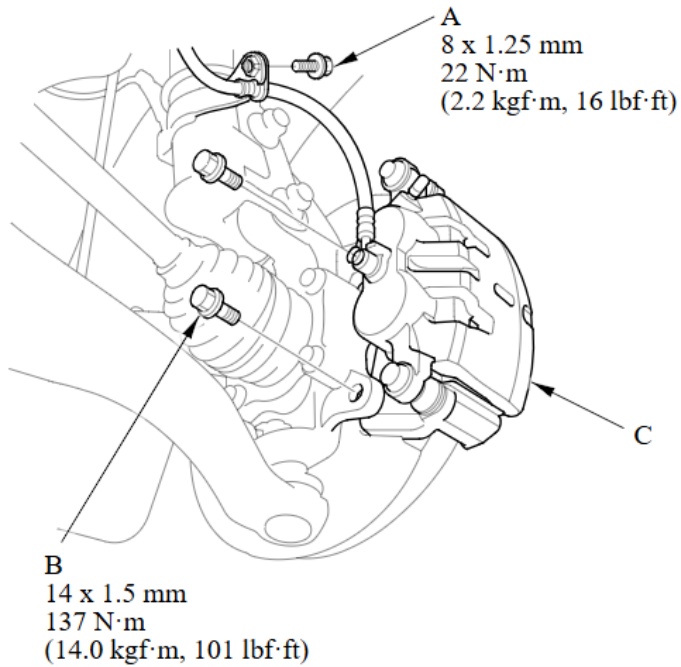

15. Remove the flange nut (A) while holding the joint pin (B) with a hex wrench (C), and disconnect the upper stabilizer link (D) from the damper.

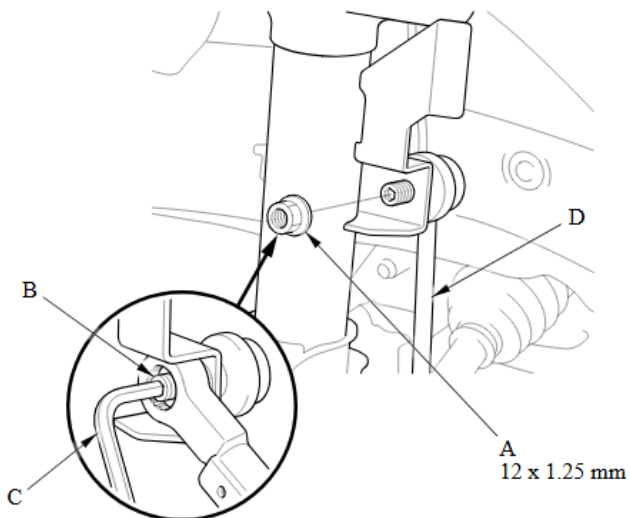

16. Remove left and right speed sensor.

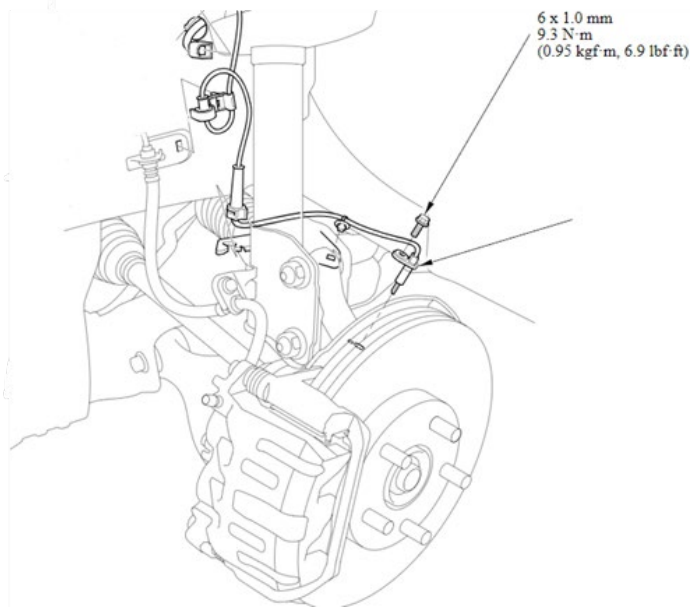

17. Disconnect the front and rear engine harness connector.

18. Disconnect front suspension stroke sensor connector (A) and unclip harness clamps.

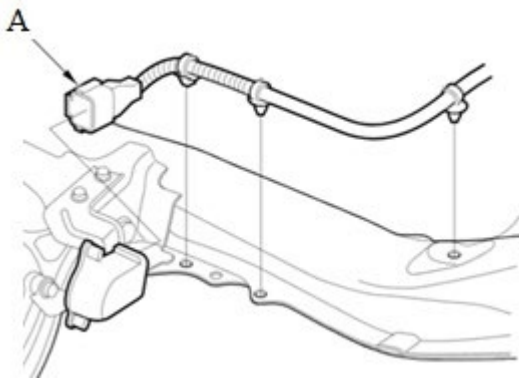

19. Disconnect the front and rear engine harness connector (A).

**FRONT**

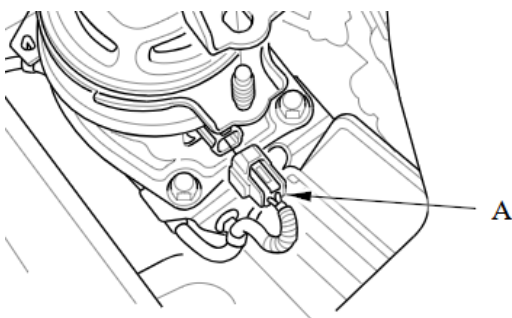

**REAR**

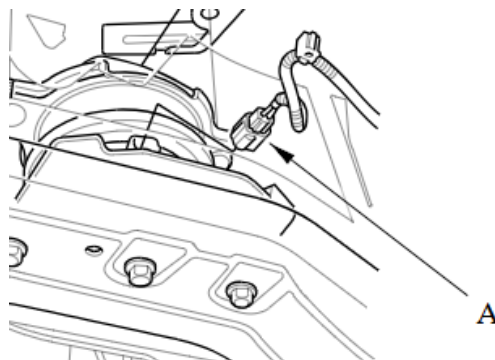

20. Disconnect the lower power steering switch connector (A).



21. Remove the CKP sensor cover and bolts, then disconnect the CKP sensor connector.

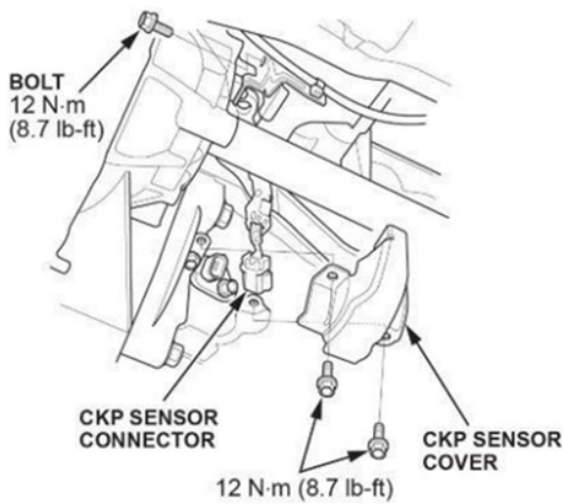

22. Loosely install the crankshaft pulley bolt.

23. Remove the torque converter case cover and the four bolts securing the oil pan to the transmission.

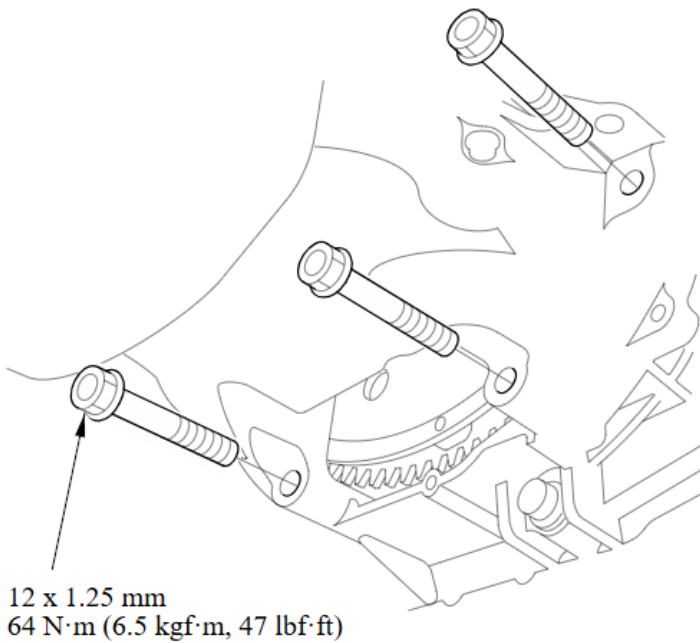

24. Remove the torque converter cover (C), then remove the eight bolts (B) that attach the drive plate (A) to the torque converter.

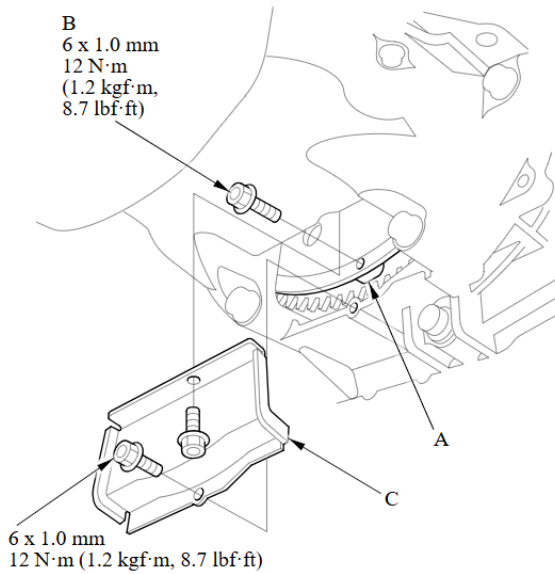

25. Position the lift table to support the engine and subframe.  
26. Set a commercially available lift pad under the transmission.

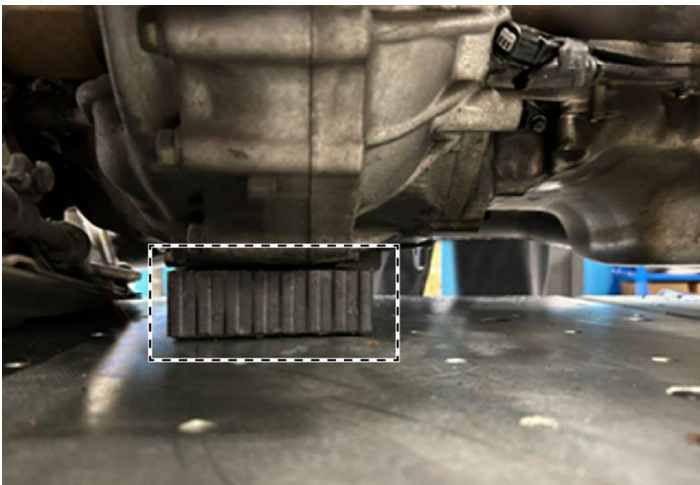

27. Lift the vehicle enough to set the lift table under the subframe.



28. Remove the subframe hardware with the engine and transmission still attached on the subframe. [\(Click Here\)](#)

29. Lower the lift table.

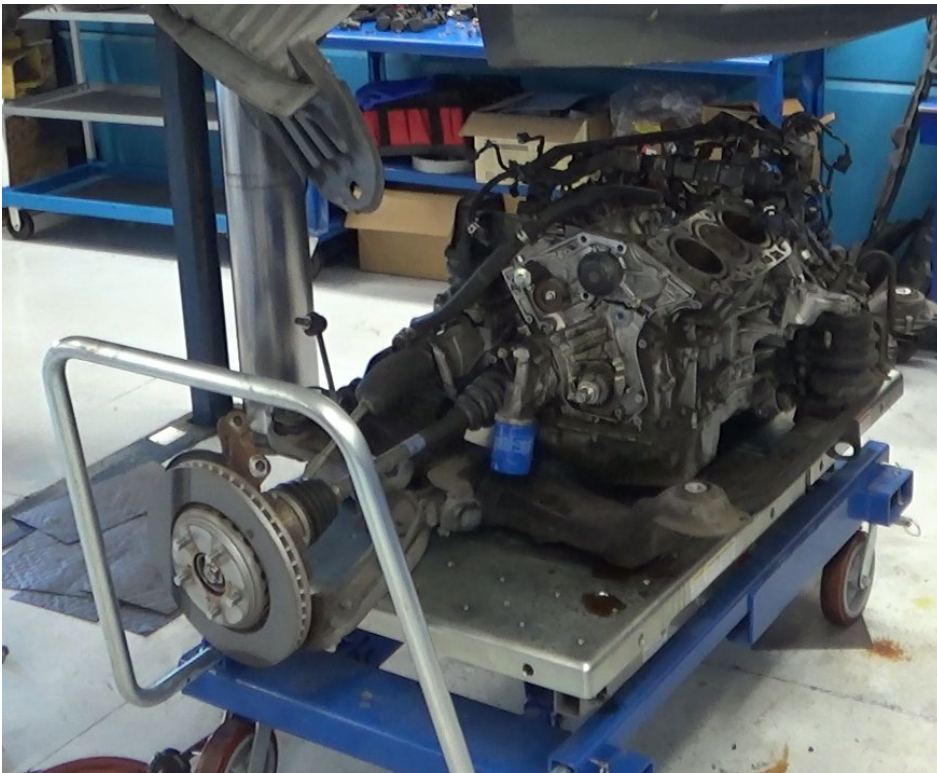

30. With the lift table out of the way, lower the vehicle.

31. Remove the dowel pins from the original engine block.

32. Remove the front engine mount stop (A), then the engine mount mounting bolt (B).

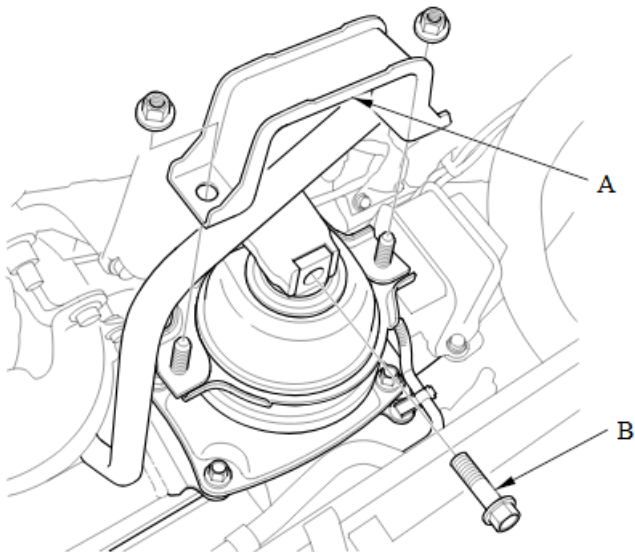

33. Remove the rear engine mount bracket (A) and engine mount (B).

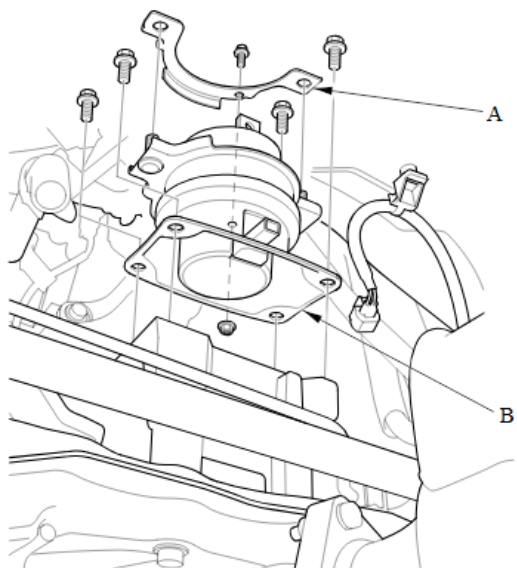

34. Remove the **right** driveshaft support base and set the driveshaft to the side. ([Click Here](#))

NOTE: Take care not to damage the driveshaft seal in the transmission.



35. Set the engine harness to the side.

36. Attach the engine hoist and engine load leveler to the engine block.



37. Using the engine hoist, raise the engine block slightly.

38. [Remove front engine mount.](#)



39. Remove the front engine mounting bracket.

40. [Remove the rear engine mount.](#)



41. Remove the upper transmission hardware.

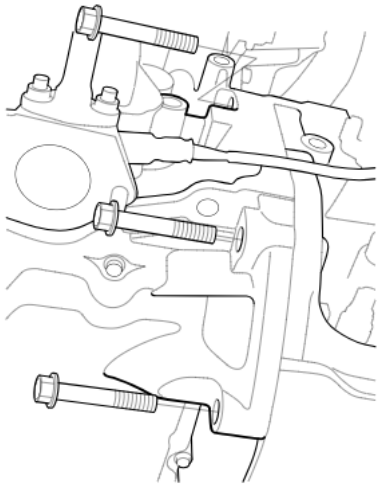

42. Separate the engine from the transmission.

43. With the engine hoist and load leveler, set the engine on a flat surface.



**Transfer remaining components to the new engine block.**

1. Remove the new engine block from the crate/box and set it on a clean flat surface. Prepare the new block for parts to be transferred from original engine block.
2. Remove the engine side mounting bracket.
3. [Remove and transfer knock sensor and knock sensor harness.](#) **32 N·m(3.3 kgf·m, 24 lbf·ft)**



4. Remove and transfer drive plate. [\(5-Speed A/T\)](#) [\(6-Speed A/T\)](#)



5. Remove and transfer the transmission dowel pins.

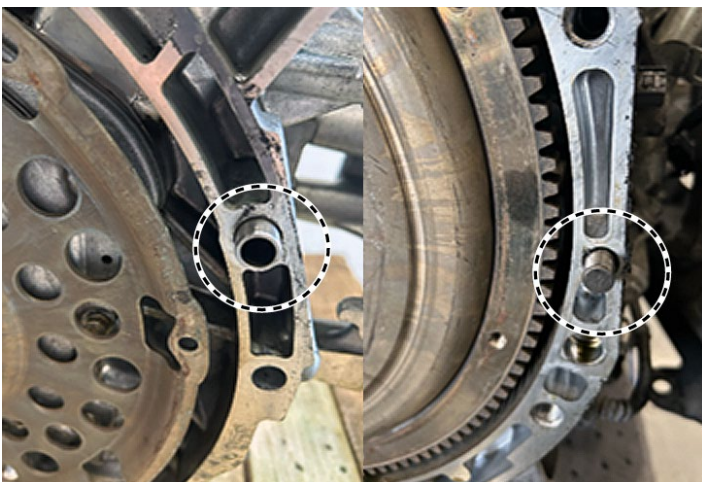

6. [Remove and transfer the front and rear engine mount brackets.](#)



7. Remove and transfer AC compressor bracket.
8. Remove and transfer [timing belt stopper](#), [timing belt drive pulley](#) and remove crankshaft pulley bolt.
9. [Remove and transfer idler pulley.](#)
10. [Remove and transfer the timing belt adjuster.](#)
11. [Remove and transfer CKP Sensor.](#)
12. Reinstall all removed parts in the reverse order of removal.

### Engine Installation

1. With the engine hoist, lift the new engine block and line up onto the transmission.  
NOTE: Make sure the dowel pins are in the transmission.
2. [Install upper transmission hardware.](#)
3. Install the [front and rear engine mount and bracket.](#)
4. Remove the engine hoist.
5. Re-install the right driveshaft and driveshaft base. [Driveshaft Installation](#)
6. [Install A/C compressor bracket.](#)
7. Install the water pipe with new O-rings onto the engine block.

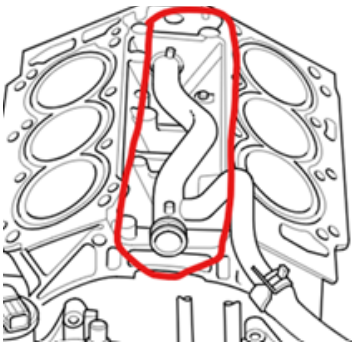

8. [Install front and rear cylinder heads.](#)

**FOR CYLINDER HEAD INSTALLATION**

NOTE: The crankshaft and camshafts should be set to TDC. Below are the steps for cylinder head bolt torque specifications:

1. Apply new engine oil to the threads and under the bolt heads.
2. Torque the cylinder bolts in sequence to **29 N•m (22 lb-ft)**.
3. Tighten in sequence an additional **90 degrees** (third step).
4. Tighten in sequence an additional **90 degrees** (fourth step).
5. **If the bolts are new**, tighten an additional 90 degrees.

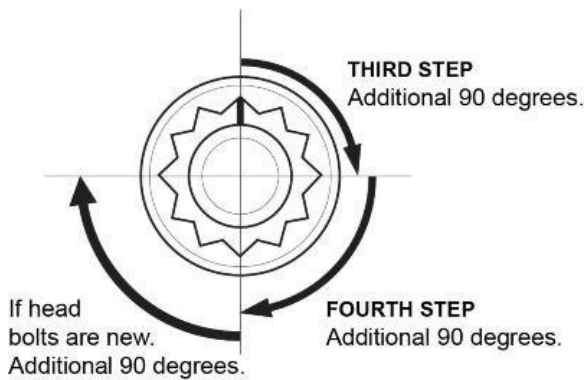

**Cylinder Head Bolt Installation Sequence**

Front

Rear

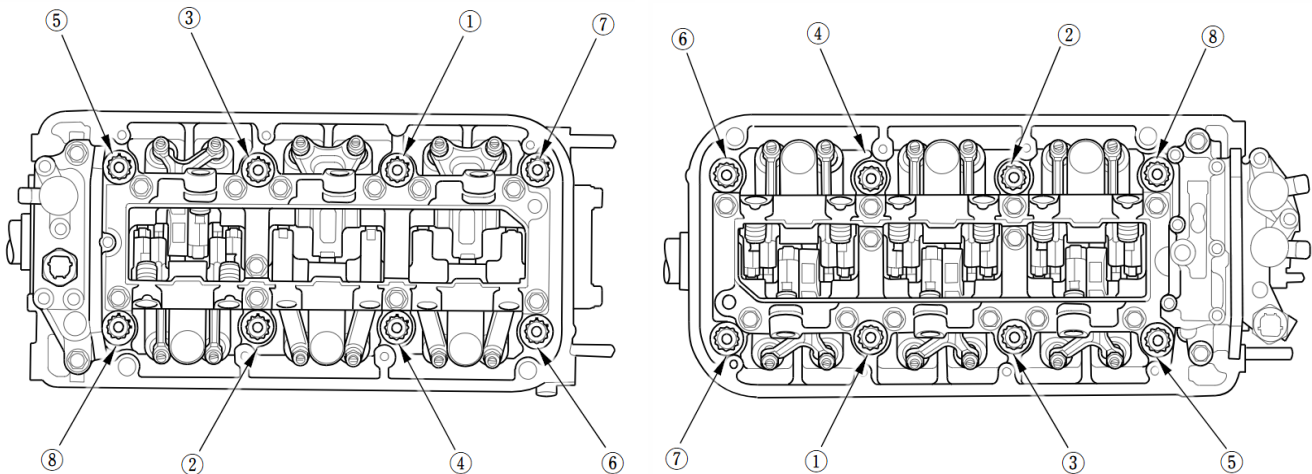

9. Install timing belt, engine side mount, timing covers and crank pulley ([Click Here](#)).
10. [Install crankshaft pulley.](#)
11. [Perform valve clearance check and adjust.](#)
12. [Install valve covers.](#)
13. [Install water passage with new water passage gaskets.](#)

14. Install fuel joint pipe with new O-rings.

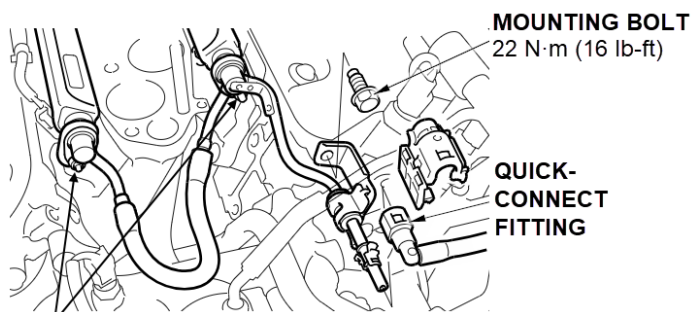

**NUTS**  
12 N·m (9 lb-ft)

15. [Connect engine wire harness connectors.](#)

16. Install the connector bracket to the front cylinder head, tighten the bolt to the specified torque.

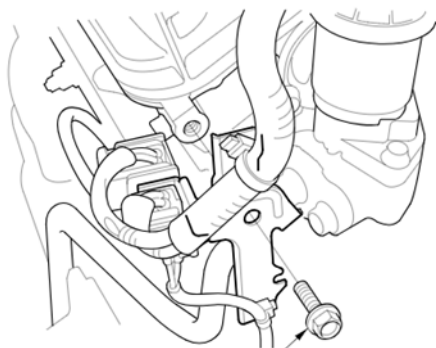

10 x 1.25 mm  
22 N·m (2.2 kgf·m, 16 lbf·ft)

17. Install the harness bracket to the rear cylinder head, tighten the bolt to the specified torque.

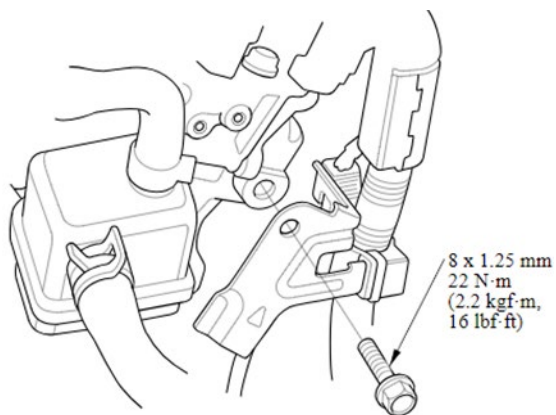

8 x 1.25 mm  
22 N·m  
(2.2 kgf·m,  
16 lbf·ft)

18. [Install intake manifold with new intake manifold gasket, upper cover and new upper cover gasket.](#)

19. [Install front and rear catalytic converter.](#)

20. Install rear engine mount stop and heat shield, torque bolts to **93 N·m (9.5 kgf·m, 69 lbf·ft)**.

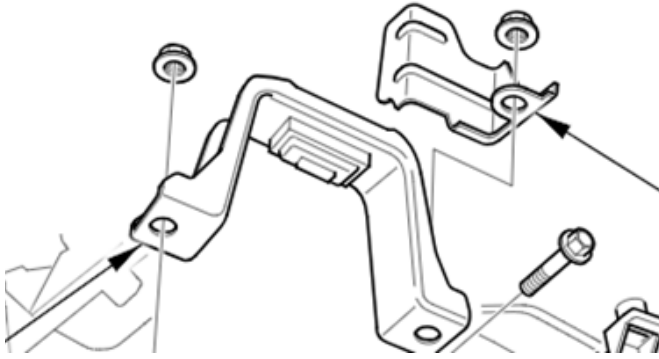

21. [Install starter assembly.](#)

22. [Install EGR pipe.](#)

23. [Install ignition coils and connectors.](#)

### **Engine and Transmission Going into the Vehicle.**

1. Line up the engine lift table and subframe under the vehicle.

2. Raise the lift table while lining up the subframe holes on bottom of the vehicle.

NOTE: Use positioning tool if needed (**P/N - 070AG-SJAA10S**) to line up subframe before hardware installation.

3. Install the subframe with new main subframe mounting bolts.

4. [Torque subframe bolts to specification onto the vehicle.](#)

NOTE: Be careful not to damage any wire harness connectors, hoses, A/C compressor when installing the subframe.

5. Install a new oil filter.

6. Reinstall all removed parts in the reverse order of removal.

## Engine in Vehicle

1. Install new oil filter.
2. Install lower transmission hardware. Torque the bolts to the specified torque **74 N·m (7.6 kgf·m, 54 lbf·ft)**.

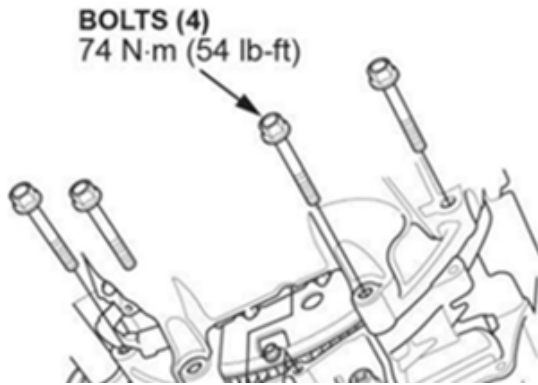

3. Connect CKP connector and CKP bracket.
4. Attach the torque converter to the drive plate (A) with eight bolts (B). Rotate the crankshaft pulley as necessary to tighten the bolts to half of the specified torque, then do the final torque in a crisscross pattern. After tightening the last bolt, check that the crankshaft rotates freely. Install the torque converter cover (C).

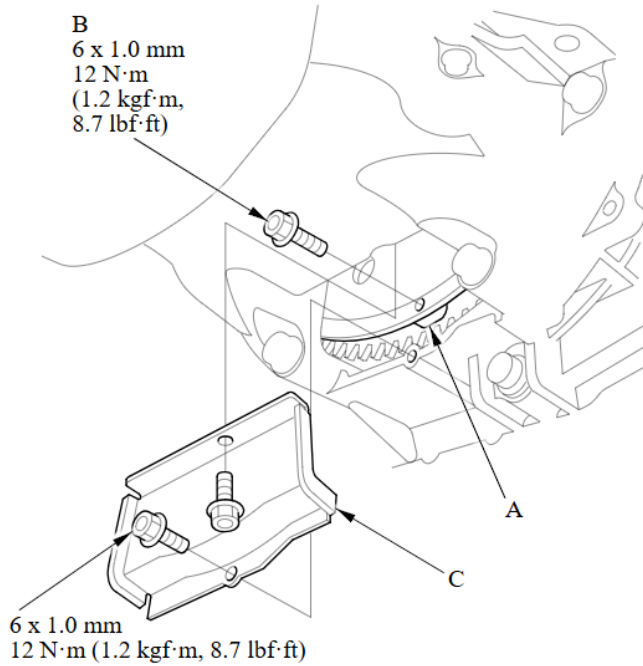

5. Connect the front suspension stroke sensor connector (A) and install the harness clamps.

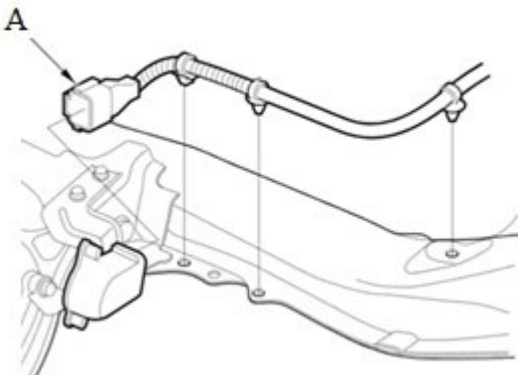

6. Connect the rear engine mount actuator connector (A).



7. Connect front engine mount actuator connector (C).

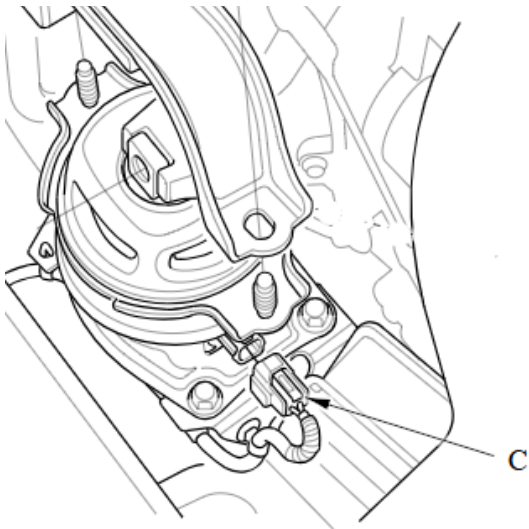

8. Connect the PSP switch connector (A) and the heat shield bolt (B).

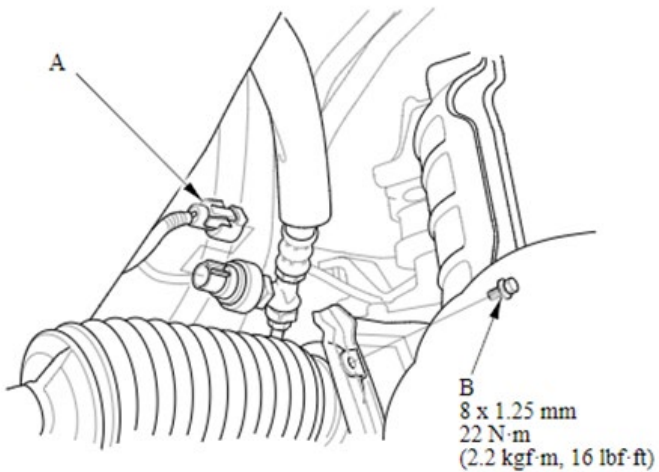

9. Connect the transmission hoses (C), then secure the hose with the clamp (D):

- [5-speed A/T model.](#)
- [6-speed A/T model.](#)

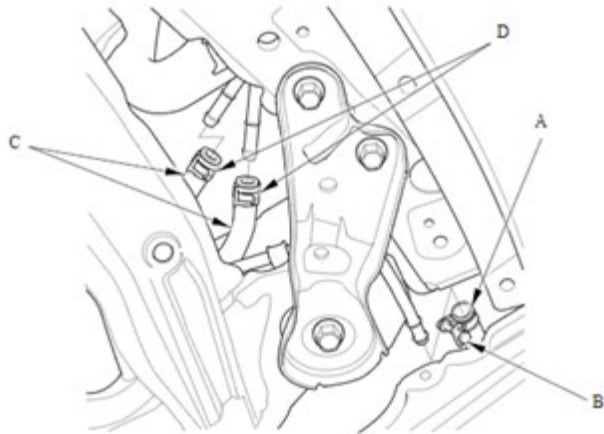

10. [Install left and right front dampers.](#)

11. Connect the upper stabilizer links to the dampers. Torque the bolts to specified torque **79 N·m (8.1 kgf·m, 58 lbf·ft)**.

12. Install left and right brake caliper. Torque the bolts to the specified torque **137 N·m (14.0 kgf·m, 101 lbf·ft)**.

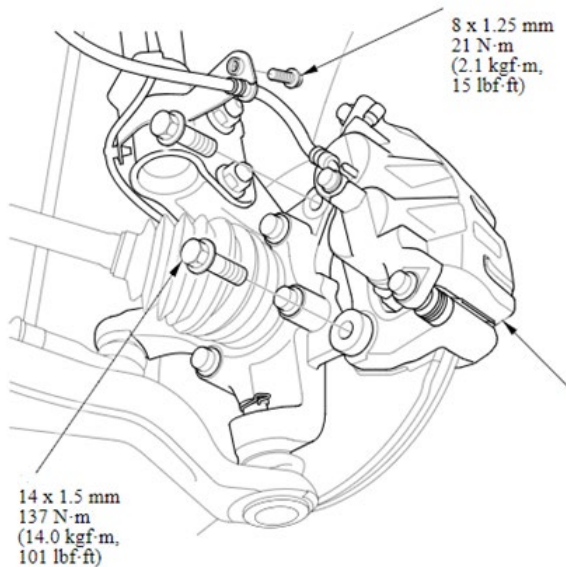

13. Install wheel speed sensors. Torque the bolts to the specified torque **9.3 N·m (0.95 kgf·m, 6.9 lbf·ft)**

14. Install transmission ground. Torque the bolt to the specified torque **12 N·m (1.2 kgf·m, 9 lbf·ft)**

15. Install front WU-TWC bracket, tighten the bolts to their specified torque .

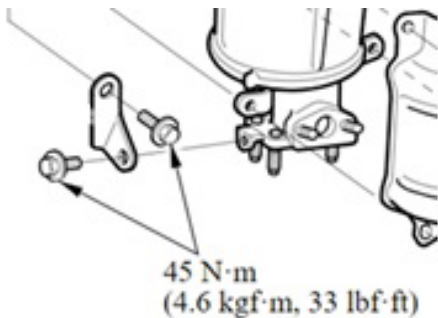

16. Install rear WU-TWC bracket, then torque the bolts to the specified torque .

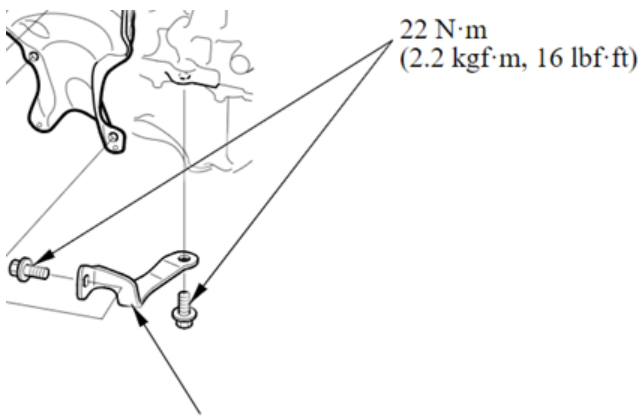

17. [Install exhaust pipe A with catalytic converter.](#)

NOTE: Use new gaskets and new self-locking nuts.

18. Install front left fender liner.

19. Lower the vehicle.

20. Install the A/C compressor hardware (A), then connect the A/C compressor clutch connector (B).

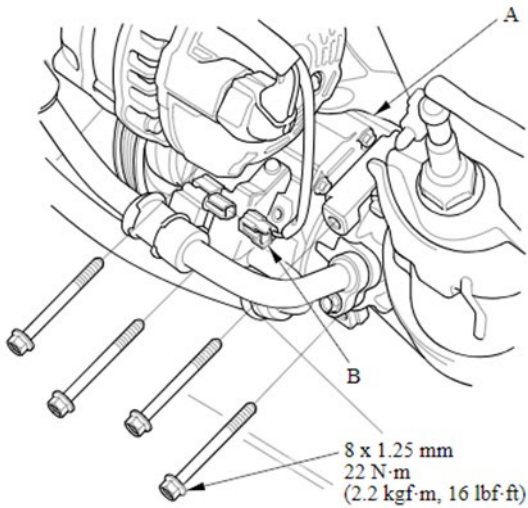

21. [Install alternator assembly.](#)

22. [Install drive belt auto tensioner.](#)

23. Install the power steering pump (A), then install the bolt (B) securing the power steering hose bracket (C).

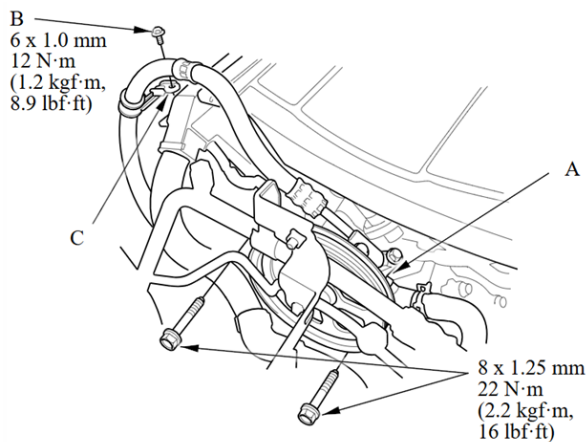

24. Connect the power steering pump inlet hose (C) and the power steering pump outlet hose (A) with new O-ring (B) to the power steering pump. Attach the power steering hose bracket (D). Tighten the bolts to their specified torque.

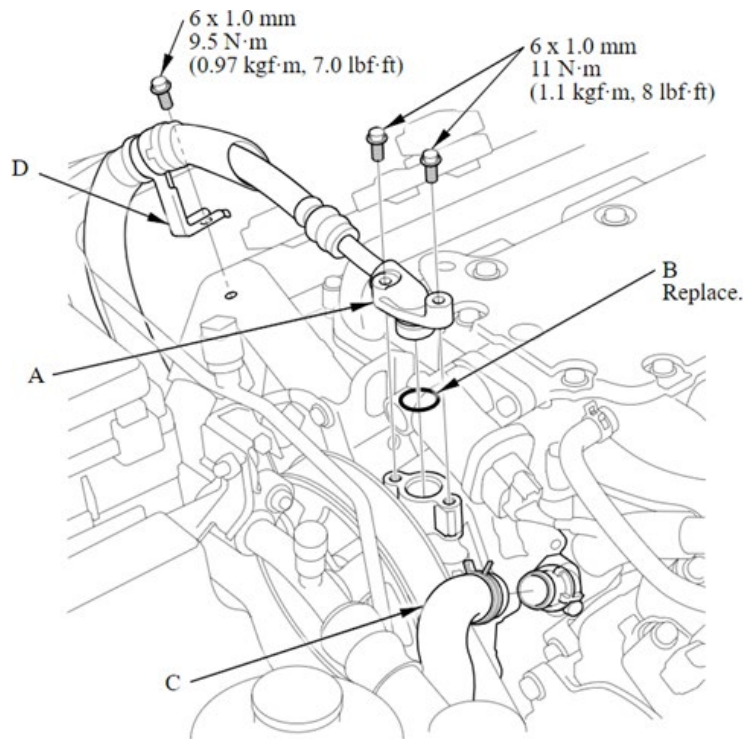

25. [Install the drive belt.](#)

26. Install the side engine mount (A) and the wire harness bracket (B). Tighten the bolts to their specified torque.

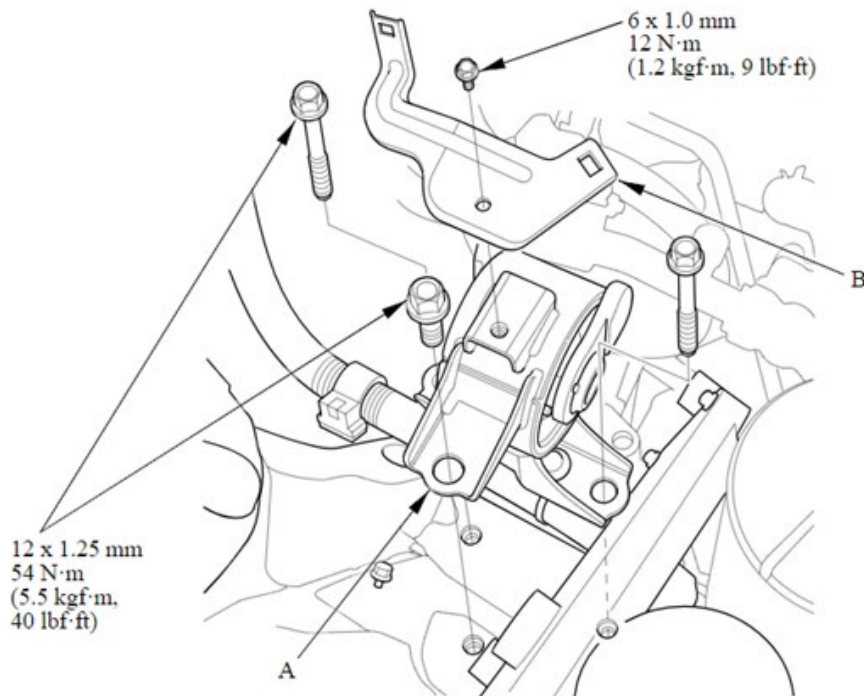

27. Loosely install the upper half of the side engine mount bracket (A) using new bolts, then install the ground cable bracket (B). Tighten the bolts to their specified torque.

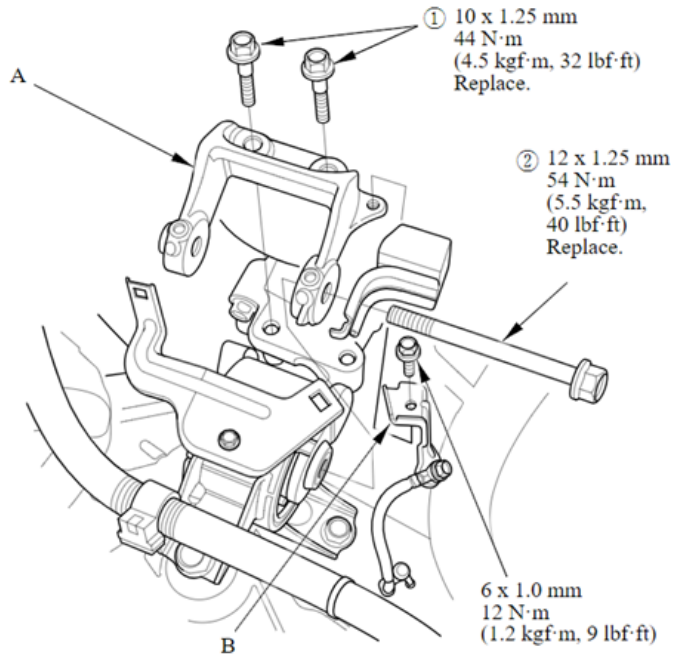

28. Install PCM with PCM bracket.

29. Connect PCM and harness clamps.

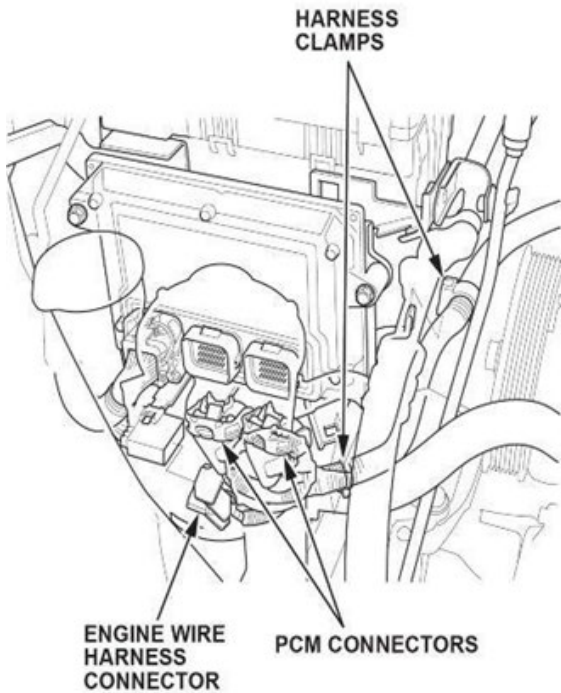

30. Install the PCM cover.

Keihin PCM

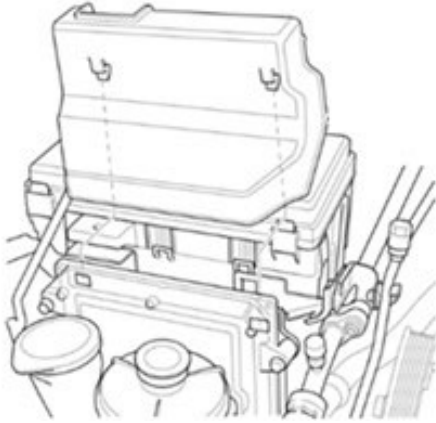

Continental PCM

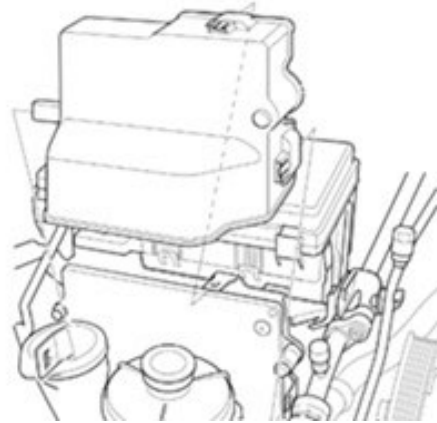

31. Connect the EVAP canister hose (E), the EVAP canister purge valve connector (D), the throttle actuator connector (C), and the MAP sensor connector (B).

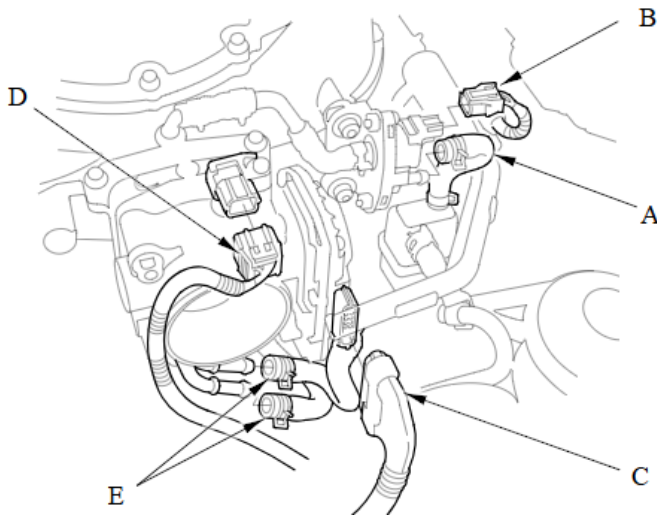

32. Connect the fuel feed hose (A), install the quick-connect fitting cover (B), then install hardware.

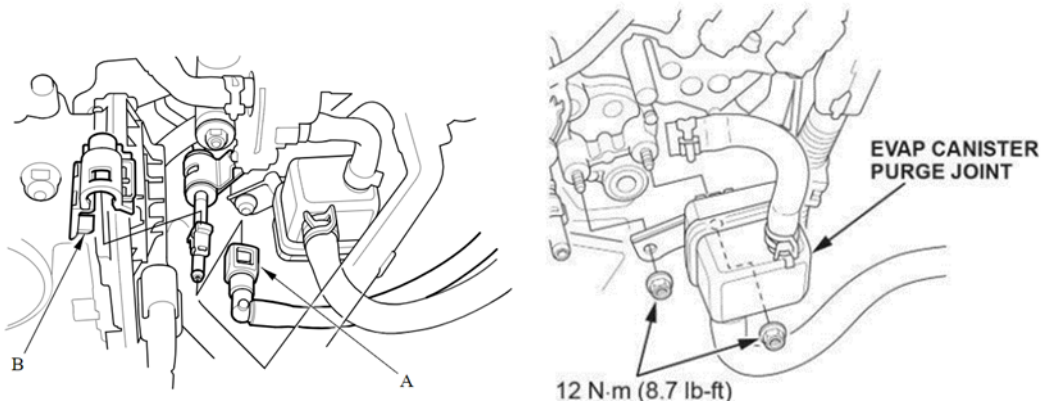

33. Install transmission shifter cable.

[5 AT](#)

[6 AT](#)

34. Install the Positive cable and nut on the starter and torque to **9.0 N·m (6.6 lbf-ft)**.

35. Connect the heater hoses (A).

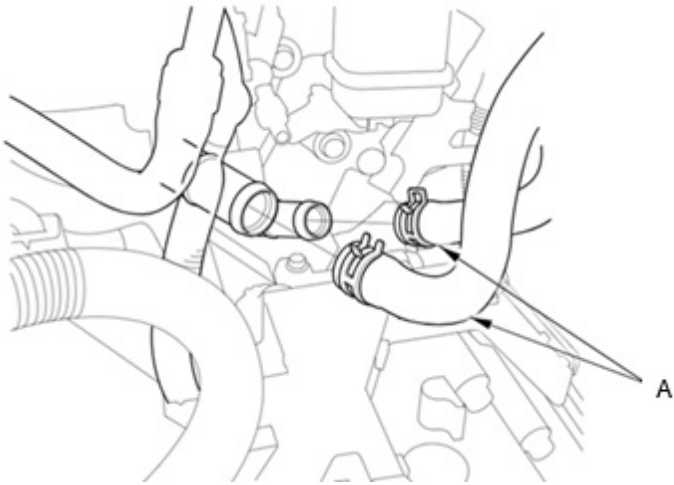

36. Connect the [ATF Cooler Lines](#).

37. Connect upper and lower radiator hoses.

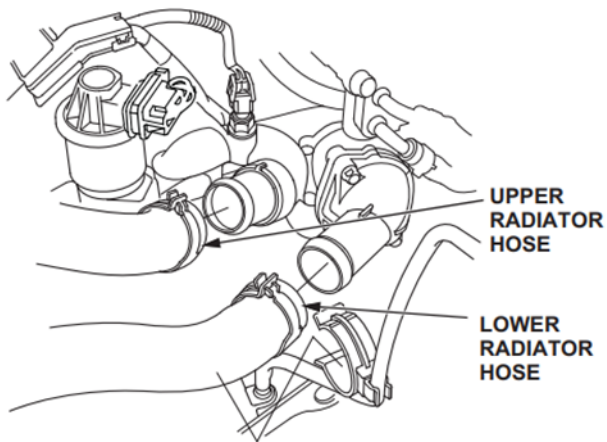

38. Install the battery base (A), and the harness clamps (B), then tighten the bolts (C) to **22 N·m (2.2 kgf·m, 16 lbf·ft)**.

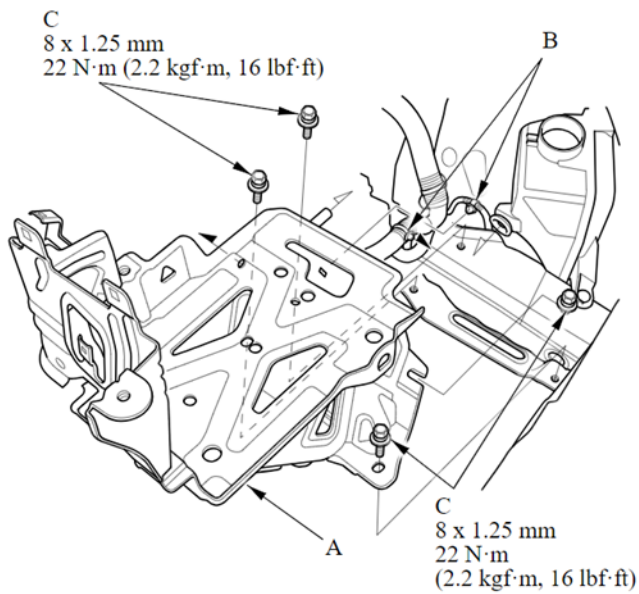

39. Install the main under-hood fuse box (A) and the harness clamps (B), then connect the engine wire harness (C) and starter cables (D) to the main under-hood fuse box.

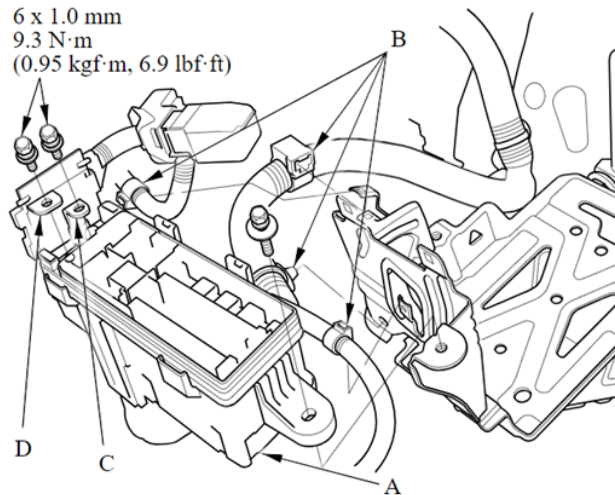

40. [Install the air cleaner.](#)
41. Install the engine cover.
42. [Do the Battery installation procedure.](#)
43. Lift the vehicle.
44. Install the right fender liner.
45. Install the splash shield.
46. Install the wheels.
47. Lower the vehicle.
48. Connect steering joint to steering gear box, then torque the bolt to **29 N·m (3.0 kgf·m, 21 lbf·ft)**.

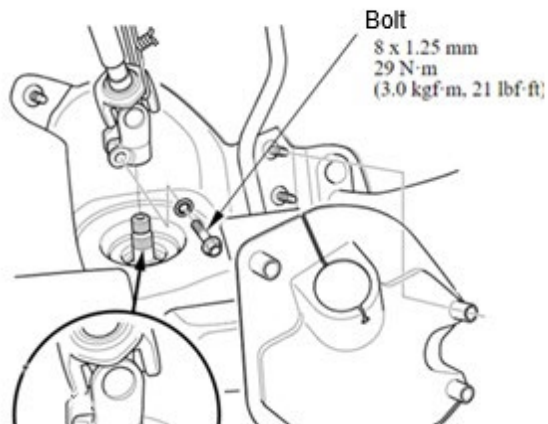

49. [Refill the engine with engine oil.](#)
- After Engine Overhaul: 5.0 L (5.3 US qt)**
50. Refill the transmission with ATF:
- [5-speed A/T model](#)
- [6-speed A/T model](#)
51. Move the shift lever to each gear and verify that the A/T gear position indicator follows the transmission range switch.
52. [Refill the reservoir with power steering fluid.](#)

53. [Refill the radiator with engine coolant.](#)
54. Move the shift lever to each gear and verify that the A/T gear position indicator follows the transmission range switch.
55. Inspect for fuel leaks. Turn the ignition switch to ON (II) (do not operate the starter) so the fuel pump runs for about 2 seconds and pressurizes the fuel line. Repeat this operation three times, then check for fuel leakage at any point in the fuel line.
56. [Do the PCM reset procedure.](#)
57. Check the PCM software version P/N located above the PGM-FI Data List.

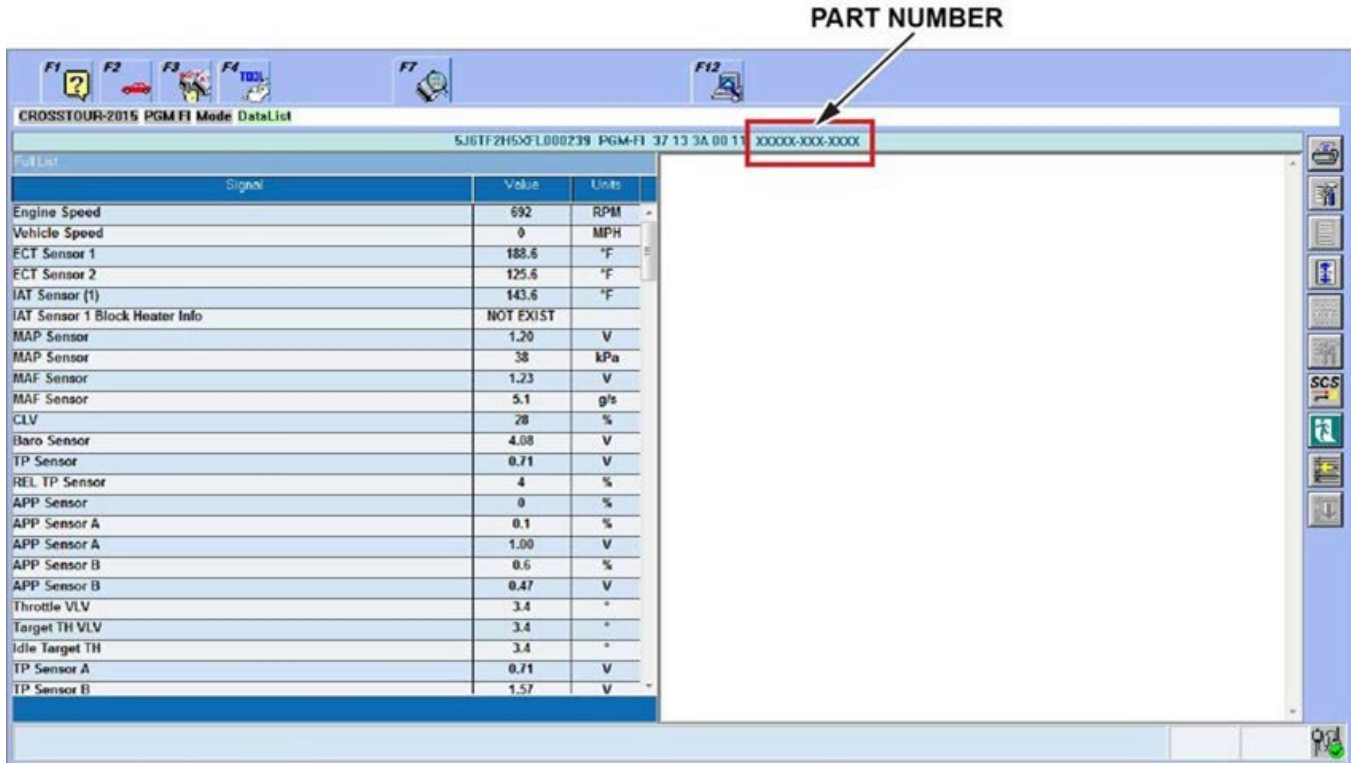

Year	Model	Program ID
2013	Odyssey	37805-RV0-C010 (5AT) 37805-RV0-C110 (6AT)
2014–16	Odyssey	37805-RV0-A660
2017	Odyssey	37805-RV0-A020

58. Do the PCM update, if needed.
 

NOTE: For information on updating the PCM see service bulletin 22-100 Updating Control Units/Modules with the Honda ECU Reprogramming Application.

Is the PCM Program ID and/or Program P/N current than what is listed?

  - **YES** – The correct software is installed
  - **NO** – The PCM software needs to be updated
59. [Do the CKP pattern clear/CKP pattern learn procedure.](#)
60. [Inspect the idle speed.](#)
61. [Do the cooling system bleeding procedure.](#)
62. Lift the vehicle.
63. Check for fluid leaks.

58. Lower the vehicle
59. [Check the wheel alignment.](#)
60. Perform a road test.