

**July 18, 2025**

Version 2

## Warranty Extension: 2013–15 Pilot MIL Comes on with DTCs P0301 Thru P0304 (6 Months)

Superseded 25-060 dated June 17, 2025, to revise the information highlighted in **yellow**.

### REVISION SUMMARY

- Under PARTS INFORMATION, Flange Bolt (side mount bolt to frame bracket) 90163-SDA-A01, was removed from Repair Procedure A parts list.
- Under REPAIR PROCEDURE B, the numbering for steps 49-51 was corrected on page 66.

### APPLIES TO

Year	Model	Trim Level	VIN Range
2013–15	Pilot	ALL	Check the iN VIN status for eligibility.

### BACKGROUND

The piston ring function deteriorates due to ring low wear toughness and sticking from sludge. Oil adheres to the spark plug leading to carbon fouling and misfire. This can set DTCs P0301 No. 1 cylinder misfire detected, P0302 No. 2 cylinder misfire detected, P0303 No. 3 cylinder misfire detected, P0304 No. 4 cylinder misfire detected, and cause the MIL to come on.

American Honda is extending the warranty coverage for this condition to **January 31, 2026**. Any repair orders issued after that date are no longer valid.

### CUSTOMER NOTIFICATION

Owners of affected vehicles will be sent a notification of this campaign.  
Do an iN VIN status inquiry to make sure the vehicle is shown as eligible.

### CORRECTIVE ACTION

Complete the DIAGNOSIS PROCEDURE and, if necessary, update the PCM software, replace affected spark plugs then clean pistons and replace the piston rings. If the cylinder wall inspection fails, perform an engine block replacement, replace the affected spark plugs and update the PCM software.

Additionally, the following videos are available to help with this bulletin:

- *Tech2Tech* "[How to Clean Piston Ring Grooves](#)"
- *Tech2Tech* "[Let's Talk Piston Ring Compressors](#)"
- *Tech2Tech* "[Check out the Cylinder Wall Inspection Tool](#)"

**CUSTOMER INFORMATION:** The information in this bulletin is intended for use only by skilled technicians who have the proper tools, equipment, and training to correctly and safely maintain your vehicle. These procedures should not be attempted by "do-it-yourselfers," and you should not assume this bulletin applies to your vehicle, or that your vehicle has the condition described. To determine whether this information applies, contact an authorized Honda automobile dealer.

## WARRANTY CLAIM INFORMATION

**FLAT RATE NOTE: Repair Procedure A** in this bulletin is different than the service manual. This procedure does not require the complete removal of the power steering pump, catalytic converter(s), engine and transmission, or the crankshaft. As a result, the operation number is unique and the FRT is reduced.

### DTC P0301, P0302, or P0303

#### No Scratching or Scoring Detected

Operation Number	Description	Flat Rate Time	Defect Code	Symptom Code	Template ID	Failed Part Number
1115A7	<b>DTC P0301, P0302, or P0303.</b> Inspect spark plug(s).	0.3 hr	6Z600	GLU00	A25060A	13021-R70-A11
A	<b>Repair Procedure A:</b> Remove cylinder head, inspect cylinders, clean pistons 1-3, replace piston rings 1-3, and replace spark plugs 1-4 (includes idle learn).	8.9 hr				
C	Update the PCM software (includes DTC clear).	0.1 hr				

#### Scratching or Scoring Detected

Operation Number	Description	Flat Rate Time	Defect Code	Symptom Code	Template ID	Failed Part Number
1115A7	<b>DTC P0301, P0302, or P0303.</b> Inspect spark plug(s).	0.3 hr	6Z600	GLU00	A25060B	13021-R70-A11
B	<b>Repair Procedure B:</b> Remove cylinder heads, inspect cylinders, replace short block and replace spark plugs 1-4 (includes idle learn and align).	10.3 hr				
C	Update the PCM software (includes DTC clear).	0.1 hr				
D	For AWD - Add	0.4 hr			A25060C	

**DTC P0304**

**No Scratching or Scoring Detected**

Operation Number	Description	Flat Rate Time	Defect Code	Symptom Code	Template ID	Failed Part Number
1115A8	<b>DTC P0304</b> Inspect spark plug(s).	0.3 hr	6Z600	GLU00	A25060D	13021-R70-A11
A	<b>Repair Procedure A:</b> Remove cylinder heads, inspect cylinders, clean pistons 1-4, replace piston rings 1-4, and replace spark plugs 1-4 (includes idle learn).	10.8 hr				
C	Update the PCM software (includes DTC clear).	0.1 hr				

**Scratching or Scoring Detected**

Operation Number	Description	Flat Rate Time	Defect Code	Symptom Code	Template ID	Failed Part Number
1115A8	<b>DTC P0304</b> Inspect spark plug(s).	0.3 hr	6Z600	GLU00	A25060E	13021-R70-A11
B	<b>Repair Procedure B:</b> Remove cylinder heads, inspect cylinders, replace short block and replace spark plugs 1-4 (includes idle learn and align).	10.3 hr				
C	Update the PCM software (includes DTC clear).	0.1 hr				
D	For AWD - Add	0.4 hr			A25060F	

**PARTS INFORMATION**

**Repair Procedure A - Piston Cleaning and Ring Replacement**

Part Name	Part Number	Quantity	
		Cyl 1-3	Cyl 1-4
Cyl. Gasket (Fr)	12251-R70-A01		1
Cyl. Gasket (Rr)	12261-R70-A01	1	1
Drain Washer 14 mm	94109-14000	1	1
EGR Pipe Gasket A	18716-R70-A01	1	1
EGR Pipe Gasket B	18719-R70-A01	1	1
Ex. Chamber Gasket	18115-R70-A01 or 18115-5G0-A01	1	2
Ex. Pipe Gasket	18212-SA7-003	2	2
Head Gasket Fr. (Valve Cover)	12030-R70-A00		1
Head Gasket Rr. (Valve Cover)	12050-R70-A00	1	1
In. Manifold Gasket (Intake Top Cover)	17146-R70-A01	1	1
In. Manifold Gasket (In. Manifold to Base)	17105-RCJ-A01	1	1
Oil Filter	15400-PLM-A02	1	1
O-ring (7.47 mm x 3.6 mm)	91301-PLC-000	2	2
O-ring (31.2 mm x 4.1 mm)	91314-PH7-003	2	2
Piston Ring Set	13011-RV0-305	3	4
Pre-chamber Gasket	18393-SDB-A00	1	1
Self-locking Nut (8 mm)	90212-RCA-A01	4	8
Self-locking Nut (10 mm)	90212-SA5-003	9	9
Spark Plug	12290-R71-L01	4	4
Strainer O-ring	15221-RYE-A01	1	1
Bolt, Flange (side engine mount bolts)	90164-SHJ-A00	2	2
Bolt, Flange (12 x 115) (side engine mount bolt)	90161-SZA-A00	1	1

**Repair Procedure A - Piston Cleaning and Ring Replacement – cont.**

Part Name	Part Number	Quantity	
		Cyl 1-3	Cyl 1-4
Timing Belt Bolt	14551-RCA-A01	1	1
Water Gasket Fr.	19411-P8A-A03	1	1
Water Gasket Rr.	19412-P8A-A02	1	1

**Replace Parts as Needed for Repair Procedure A**

Part Name	Part Number	Cyl 1-3	Cyl 1-4
Connecting Rod Bolt (may require up to 2 bolts per connecting rod)	13204-P8A-A01	6	8
Washer-Bolt (12 x 163) (may require up to 8 bolts per cylinder head)	90005-PAA-A01	8	16

**Repair Procedure B - Engine Short Block Replacement**

Part Name	Part Number	Quantity
Intake Cover Gasket	17146-R70-A01	1
Intake Manifold Gasket	17105-RCJ-A01	1
Water Gasket Fr.	19411-P8A-A03	1
Water Gasket Rr.	19412-P8A-A02	1
Catalytic Converter Gasket	18115-R70-A01 or 18115-5G0-A01	2
Oil Filter	15400-PLM-A02	1
Nut, Self-Locking (catalytic converter)	90212-RCA-A01	8
Washer, Sealing (24MM) (6AT Fill Plug Washer)	11107-PWA-300	1
Washer, Drain Plug (18MM) (6AT Drain Plug Washer)	90471-PX4-000	1
Washer, Drain Plug (20MM) (5AT Drain Plug Washer)	94109-20000	1
Gasket, Prechamber	18393-SDB-A00	1
Gasket, Exhaust Pipe	18212-SA7-003	2
Nut, Self-Lock (10MM) (Exhaust pipe A nuts)	90212-SA5-003	9
Bolt, Flange (side mount bolt to frame bracket)	90163-SDA-A01	2

**Repair Procedure B - Engine Short Block Replacement – cont.**

Bolt, Flange (side engine mount bolts)	90164-SHJ-A00	2
Bolt, Flange (12X115) (side engine mount bolt)	90161-SZA-A00	1
Bolt, Flange (10X20) (Front & Rear engine mount bolts)	90163-S5A-000	8
Nut, Flange (12MM) (Front & Rear Engine Mount stopper nuts)	90371-SAA-010	4
Bolt, Flange (10X75) (Rear engine mount bolts)	95701-10075-08	2
O-Ring (8.8X2.4)	15142-P8A-A00	2
Bolt, Flange (10X50)	95701-10050-08	4
Bolt, Flange (10X30) (Front engine mount bracket bolts)	90163-SDB-A00	3
Bolt, Flange (12X83) (Rear engine mount bracket bolts)	90163-SHJ-A00	4
Bolt, Flange (10X85) (Select)	90002-R70-A00	1
Bolt, Flange (10X120)	95801-10120-08	2
O-Ring (14.4X1.9) (P.S Line)	91370-TA0-000	1
O-Ring (fuel rail O-ring)	91301-PLC-000	2
Starter Motor Gasket	31270-RJA-A01	1
Gasket A, EGR Pipe (EGR pipe gasket)	18716-R70-A01	1
Gasket B, EGR Pipe (EGR pipe gasket)	18719-R70-A01	1
Gasket, Rear Cylinder (head gasket)	12261-R70-A01	1
Gasket, Front Cylinder (head gasket)	12251-R70-A01	1
Head Gasket Fr. (Valve Cover)	12030-R70-A00	1
Head Gasket Rr. (Valve Cover)	12050-R70-A00	1
O-Ring (O-rings for coolant pipe)	91314-PH7-003	2
Timing Belt Bolt	14551-RCA-A01	1
Bolt, Timing Belt Adjuster	14513-RCA-A01	1
Bolt, Flange (strut to knuckle)	90119-SJC-A00	4
Nut, Flange (strut to knuckle)	90381-SJC-A00	4
Bolt, Flange (10X25) (Propeller Shaft)	90113-S3V-A00	4
Bolt, Flange (special bolt, subframe)	90165-SHJ-A00	4
Bolt, Flange (special bolt; rear subframe bolt)	90161-SHJ-A00	2

**Repair Procedure B - Engine Short Block Replacement – cont.**

Bolt, Flange (12X28) (subframe bracket bolt)	90181-SK3-E00	2
O-Ring (15X1.9) (CKP O-ring)	91333-PNA-003	1
Engine Short Block (2013-2015)	10002-RN0-305	1

**Replace Parts as Needed for Repair Procedure B**

Part Name	Part Number	Quantity
Washer-Bolt (12 x 163) (may require up to 8 bolts per cylinder head)	90005-PAA-A01	16

**REQUIRED MATERIALS****Repair Procedure A**

Material Description	Part Number	Quantity
Honda Long-Life Antifreeze/Coolant Type 2	08CLA-P99-0F0A8	3 gallons
Full Synthetic Engine Oil 0W-20 Oil	08798-9163	6 quarts
Hondabond HT (1 Tube Repairs 5 Vehicles)	08718-0004	1 tube
Genuine Honda Throttle Plate Cleaner	08700-TPCB	1
Nylon Parts Cleaning Brush	(commercially available)	
5/16 ID Flexible Hose	(commercially available)	

**Repair Procedure B**

Material Description	Part Number	Quantity
Honda Long-Life Antifreeze/Coolant Type 2	08CLA-P99-0F0A8	3 gallons
Full Synthetic Engine Oil 0W-20 Oil	08798-9163	6 quarts
Power steering Fluid (12oz)	08206-9002	1
ATF-DW1	08200-9008	4
Hondabond HT (1 Tube Repairs 10 Vehicles)	08718-0004	1 tube
5/16 ID Flexible Hose	(commercially available)	1

## TOOL INFORMATION

### Repair Procedure A

Tool Name	Tool Number	Quantity
Piston Ring Groove Cleaner	07AAZ-TA5A100	1
Cylinder Wall Inspection Tool	07AAJ-R70A301	1
Gasket Remover/Pan Separator	LIL50190	1
Piston Ring Expander	Snap-On PRS8 or equivalent	1
Piston Ring Compressor	SCP1289 or equivalent	1

NOTE: Each dealer was sent one cylinder wall inspection tool.

### Repair Procedure B

Tool Name	Tool Number	Quantity
Lift table	KLS6227500	1
Cylinder Wall Inspection Tool	07AAJ-R70A301	1
Engine hoist	(commercially available)	1
Load leveler	NRI78115H	1

NOTE: Each dealer was sent one cylinder wall inspection tool.

## INSPECTION PROCEDURE

1. Connect the i-HDS and check for the following DTCs:

- P0301 - No. 1 Cylinder Misfire Detected
- P0302 - No. 2 Cylinder Misfire Detected
- P0303 - No. 3 Cylinder Misfire Detected
- P0304 - No. 4 Cylinder Misfire Detected

Are any of these DTCs stored?

**YES** – Go to step 2.

**NO** – Stop. This bulletin does not apply. Continue with normal troubleshooting.

2. Relieve the fuel pressure using i-HDS. Refer to the service manual for the full procedure.

3. Remove the engine cover, then remove the appropriate Ignition coils and spark plugs based on the DTCs stored.

Example: If P0301 is stored, remove the ignition coil on cylinder No. 1.

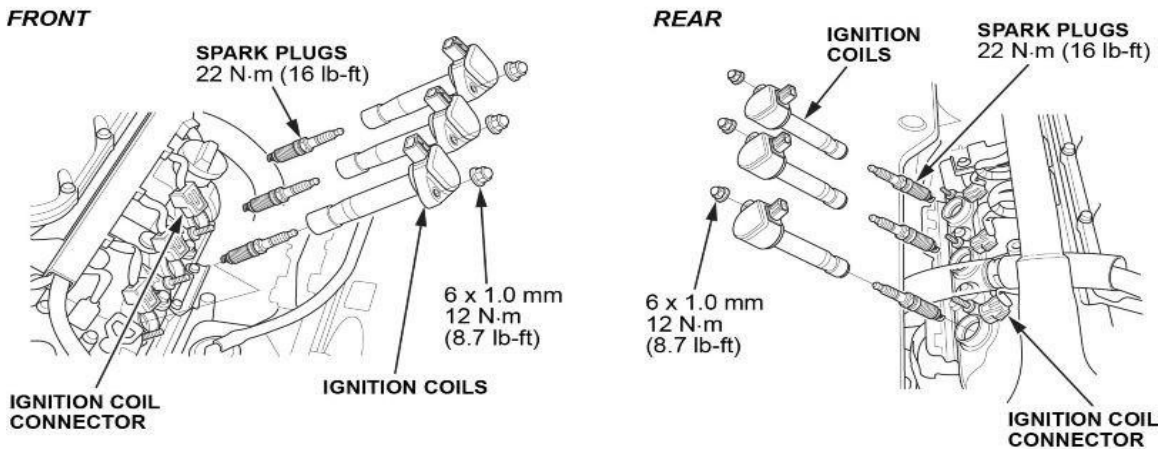

Cylinder Arrangement/Firing Order: 1-4-2-5-3-6

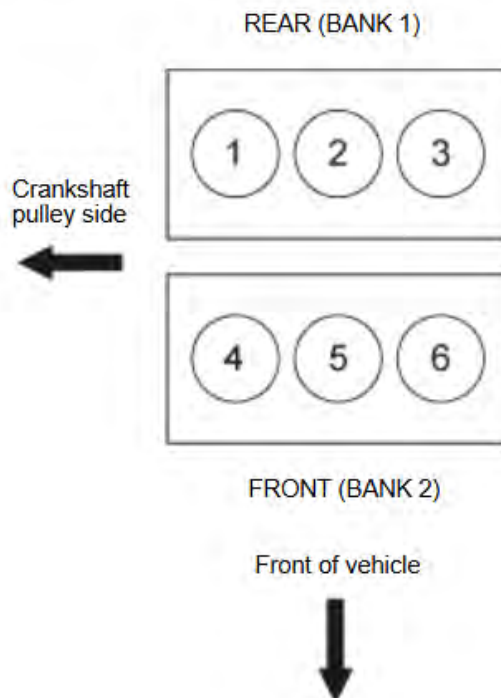

4. Check the spark plug(s) of the affected cylinder(s).

Example: If P0301 is stored, check the spark plug on cylinder No. 1.

DTC Stored	Diagnostic	Spark plug condition?	Repair Process
P0301	Remove the #1 cylinder spark plug and inspect for fouling.	Not fouled	This bulletin does not apply. Continue with normal troubleshooting.
		Fouled	Proceed to step 5.
P0302	Remove the #2 cylinder spark plug and inspect for fouling.	Not fouled	This bulletin does not apply. Continue with normal troubleshooting.
		Fouled	Proceed to step 5.
P0303	Remove the #3 cylinder spark plug and inspect for fouling.	Not fouled	This bulletin does not apply. Continue with normal troubleshooting.
		Fouled	Proceed to step 5.
P0304	Remove the #4 cylinder spark plug and inspect for fouling.	Not fouled	This bulletin does not apply. Continue with normal troubleshooting.
		Fouled	Proceed to step 5.
P0305			This bulletin does not apply. Continue with normal troubleshooting.
P0306			



5. Remove the affected cylinder head(s) to inspect the cylinder bores.

DTCs Stored with fouled spark plug(s)	Diagnostic
P0301, P0302, or P0303	Remove the <b>rear</b> cylinder head and inspect cylinder bores 1-3 for scratching or scoring using the cylinder head inspection tool.
P0304	Remove the <b>front and rear</b> cylinder heads and inspect cylinder bores 1-4 for scratching or scoring using the cylinder head inspection tool.

**NOTICE**

- Use fender covers to avoid damaging painted surfaces.
  - To avoid damaging any wires and terminals, unplug the circuit connectors carefully while holding the connector portion.
  - Mark all the circuits and hoses to avoid misconnection. Make sure they do not contact other circuit wiring, hoses, or interfere with other parts.
1. Remove both front wheels to allow the vehicle to be fully lowered.
  2. Do the 12-volt battery removal procedure.
  3. Disconnect the fuel feed hose quick-connect fitting at the bulkhead.

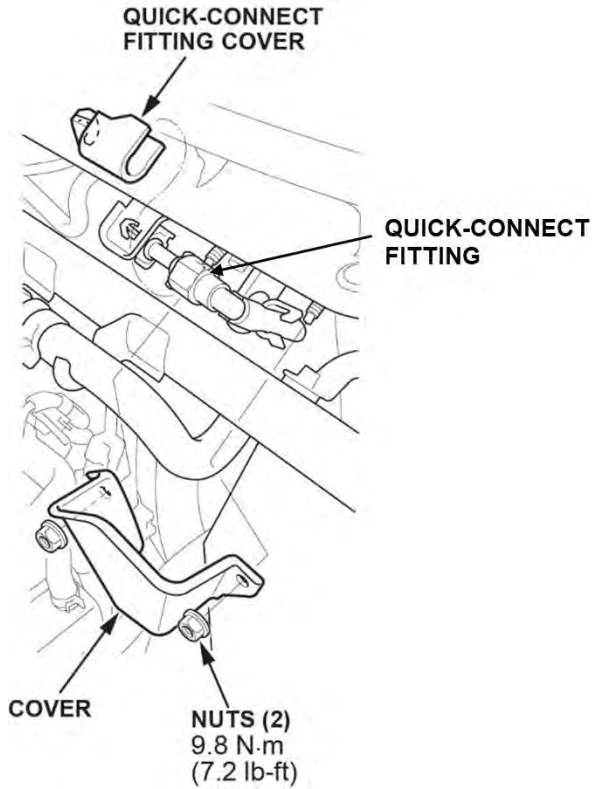

4. Remove the radiator cap.
5. Raise the vehicle.
6. Remove the front splash shield.

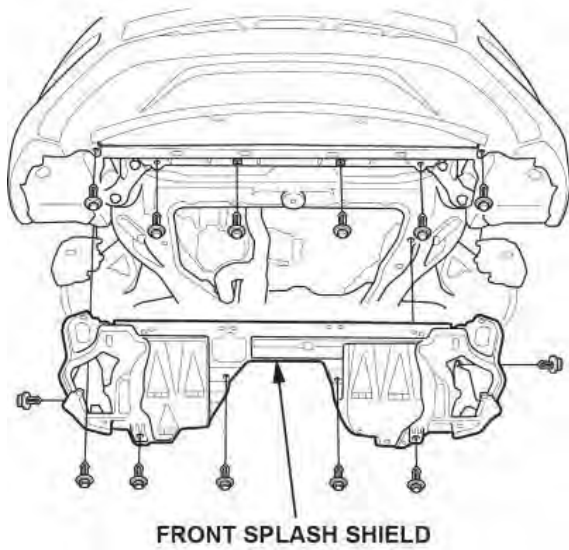

7. Drain the engine oil.
8. Loosen the drain plug on the radiator and drain the coolant.

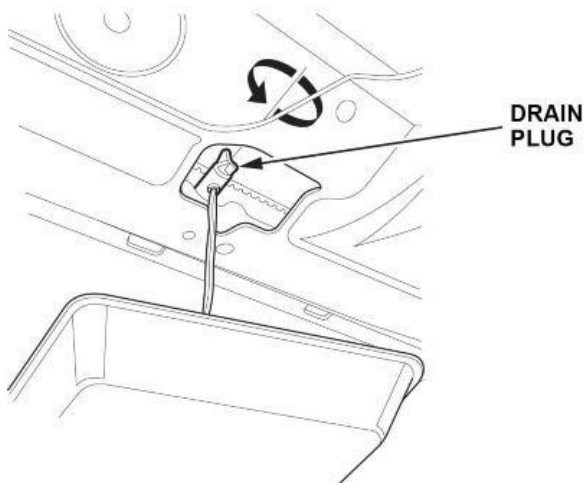

9. Drain the remaining coolant from the engine by installing a 5/16 in. inner diameter rubber hose (commercially available) onto the block drain bolt located at the rear of the engine block, then loosen the drain bolt. Then disconnect the oil pressure switch connector.

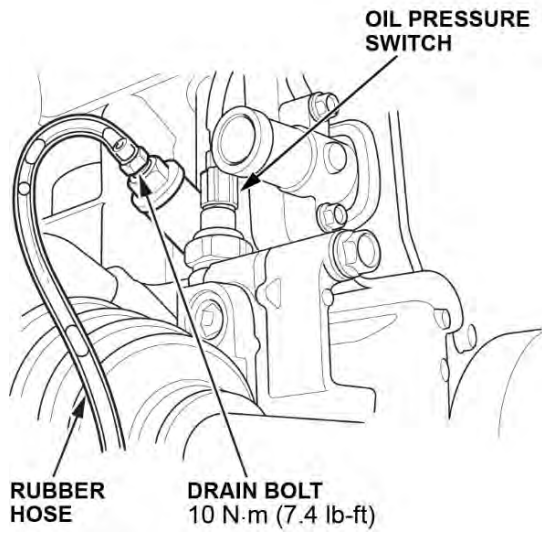

10. Remove the subframe stiffener.

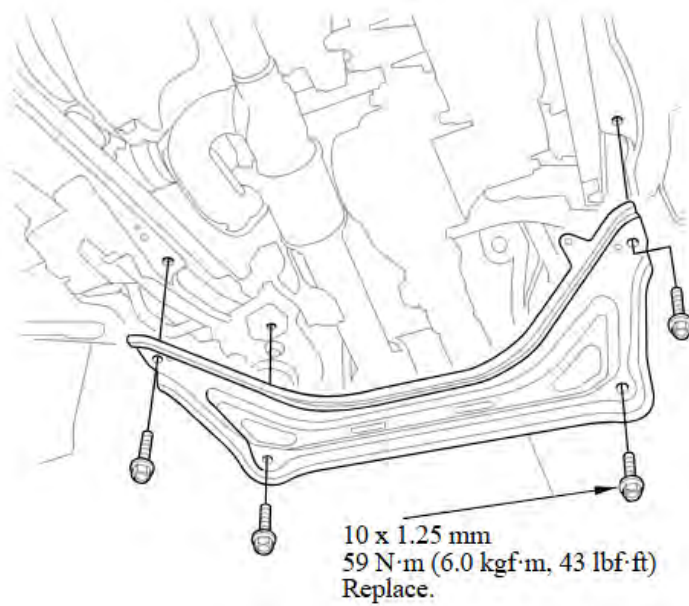

11. Remove exhaust pipe A.

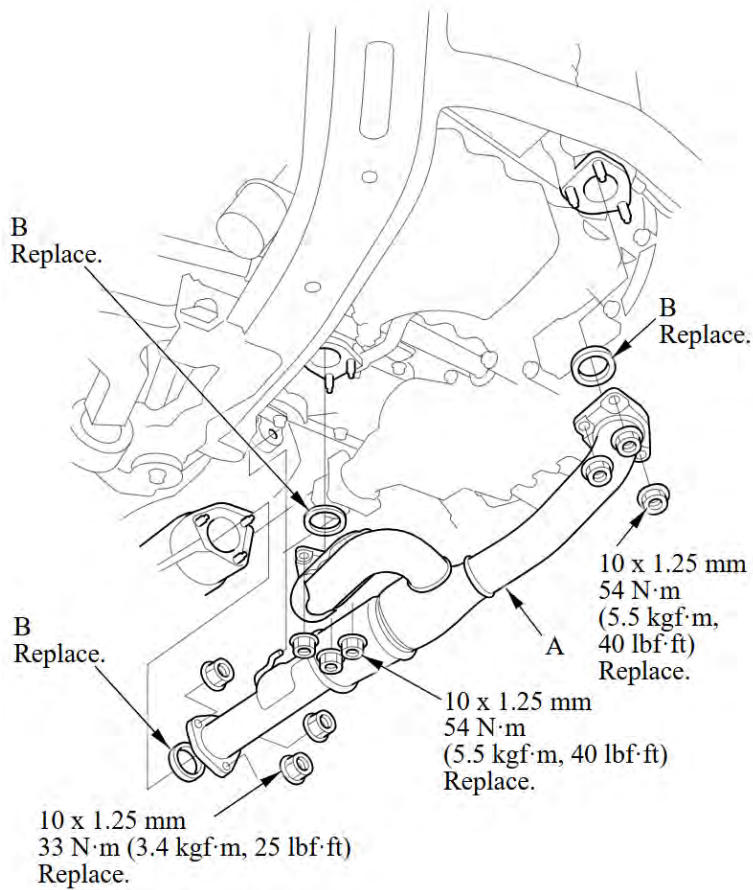

12. Depending on the diagnosis, remove either the rear or both of the WU-TWC support bracket bolts.

**FRONT WU-TWC BRACKET**

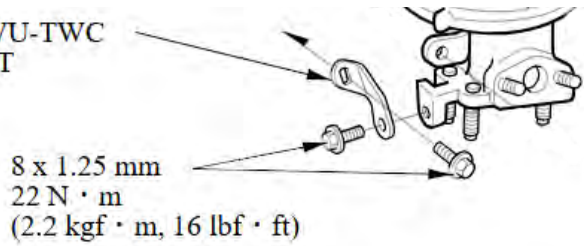

**REAR WU-TWC BRACKET**

13. Remove the EGR pipe lower mounting nuts (A).

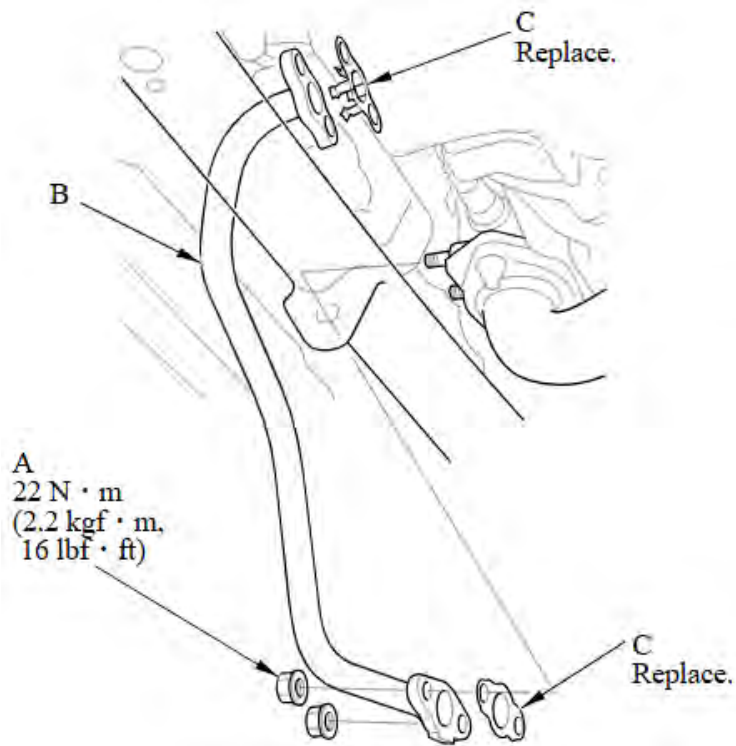

14. Remove the left front fender liner.

15. Lower the vehicle.

16. Disconnect the breather pipe (A), then remove the intake air duct (B).

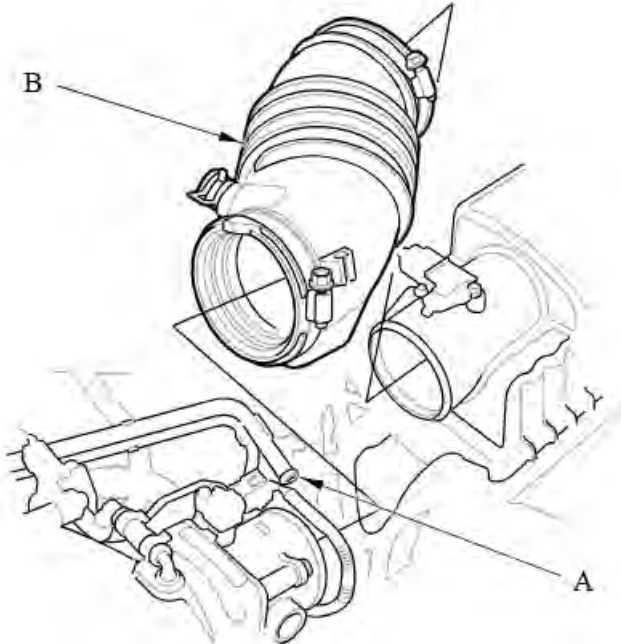

17. Disconnect the PCV hose (A), the brake booster vacuum hose (B), and the IMT actuator connector (C).

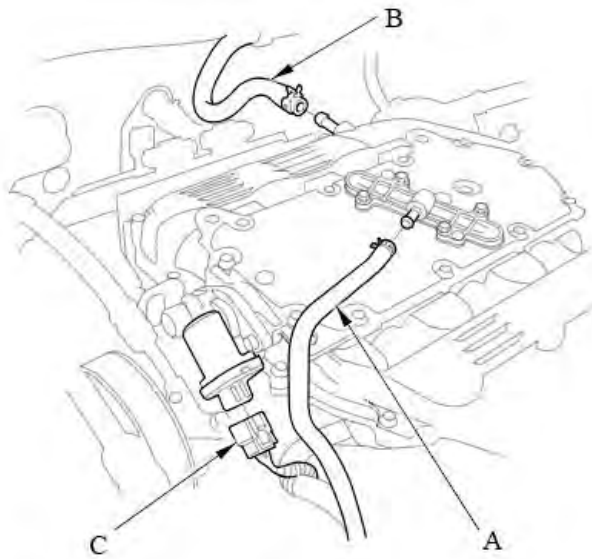

18. Disconnect the EVAP canister hose (A), the EVAP canister purge valve connector (B), the throttle actuator connector (C), and the MAP sensor connector (D). Then disconnect and plug the water bypass hoses (E).

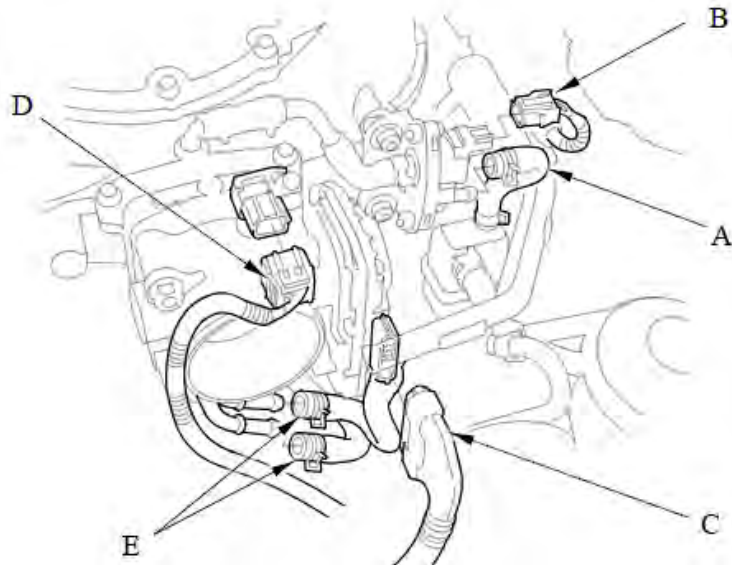

19. Remove the alternator.

20. Remove the engine intake upper cover (A).

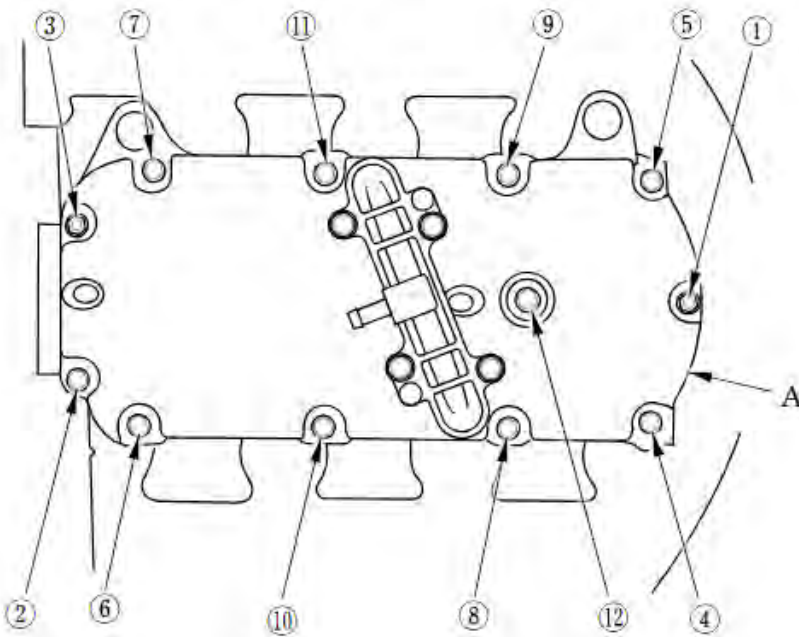

**FOR INSTALLATION:**

1. Install the upper cover (A) with a new gasket. Tighten the bolts and nuts to **12 N·m (8.9 lb-ft)** in three steps in the sequence shown below.

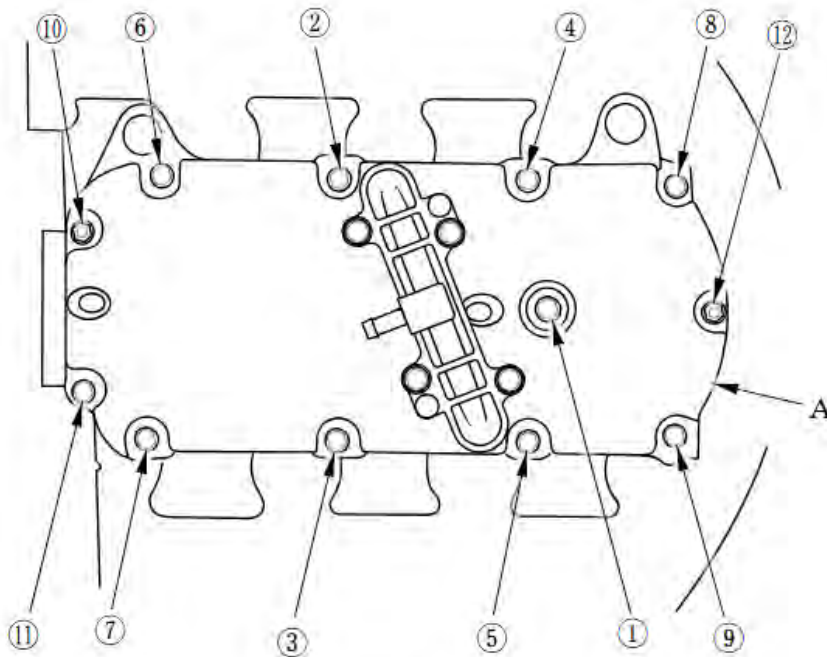

21. Remove the intake manifold bolts and nuts in **three steps**, then remove the intake manifold with the throttle body attached.

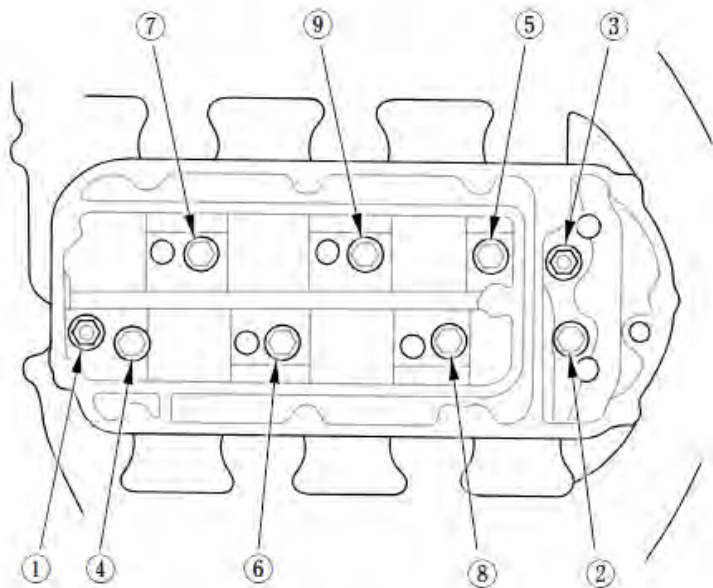

**FOR INSTALLATION:**

1. Install the intake manifold with a new gasket. Tighten the bolts and nuts to **22 N·m (16 lb-ft)** in three steps in the sequence shown below.

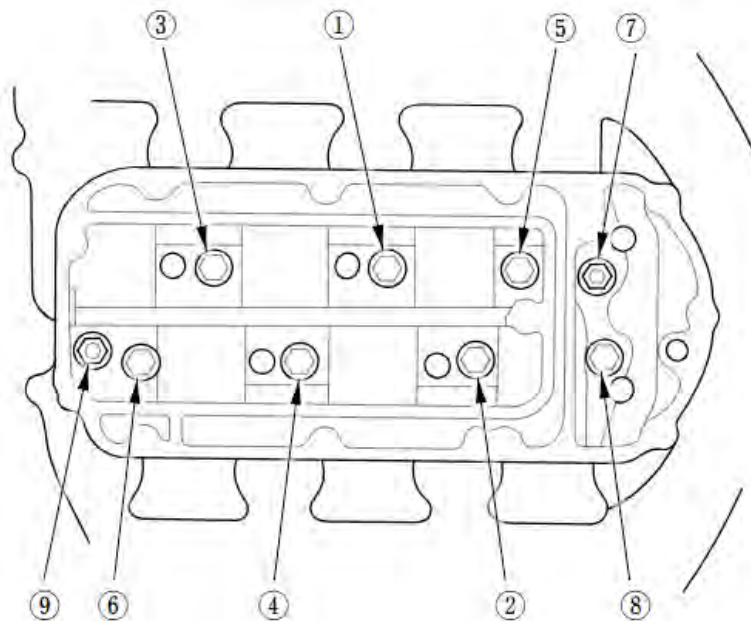

22. Lift the power steering reservoir (A) from the clamp, then remove the drive belt.

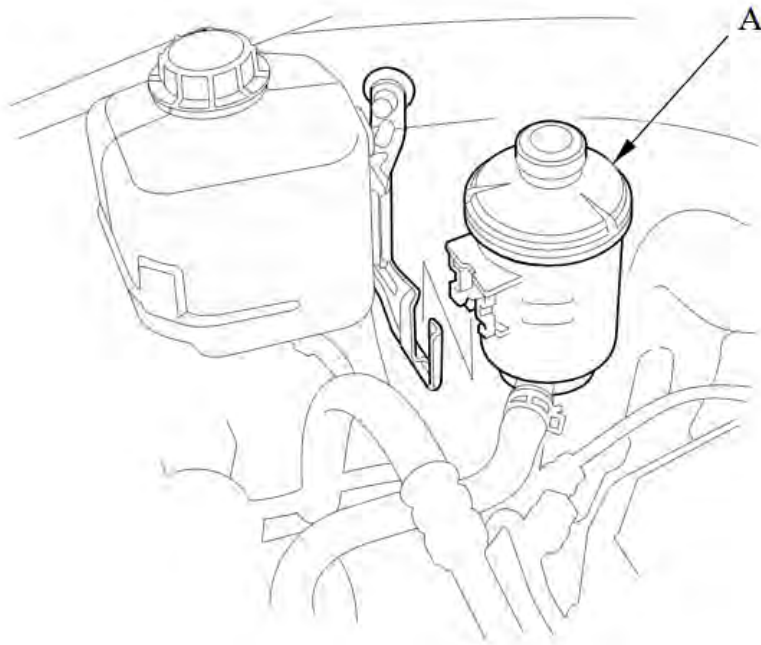

23. Remove the drive belt auto-tensioner.

24. Remove the bolt (B) securing the power steering hose bracket (C), then remove the bolts for the power steering pump (A) and secure the power steering pump out of the way.

NOTE: Do not remove any of the power steering hoses.

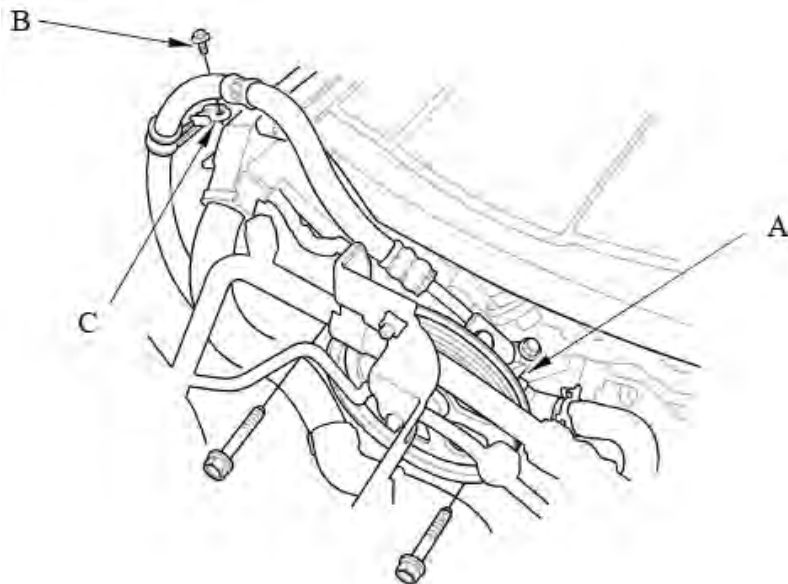

25. Remove the cylinder head cover on the affected cylinder bank(s).

26. Remove the engine harness holder bolt on the side engine mount.

27. Set the number 1 cylinder to TDC.

28. Remove the PCM cover (A).

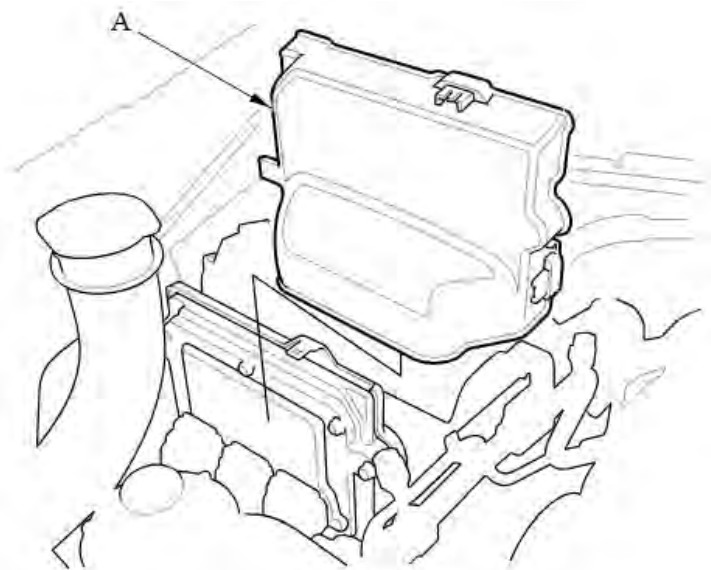

29. Remove the harness clamps (A), then disconnect the PCM connectors (B), and the engine wire harness connector (C), then remove the PCM with the bracket.

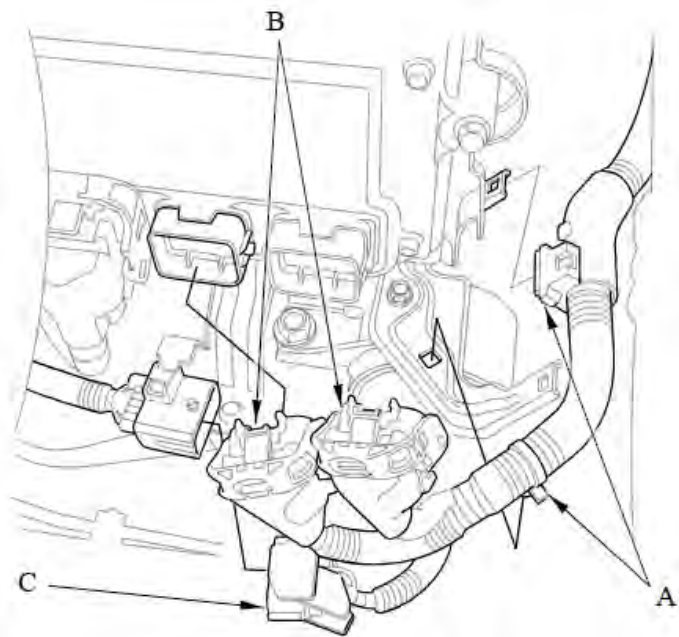

30. Remove the ground cable bracket (A), then remove the upper half of the side engine mount bracket (B).

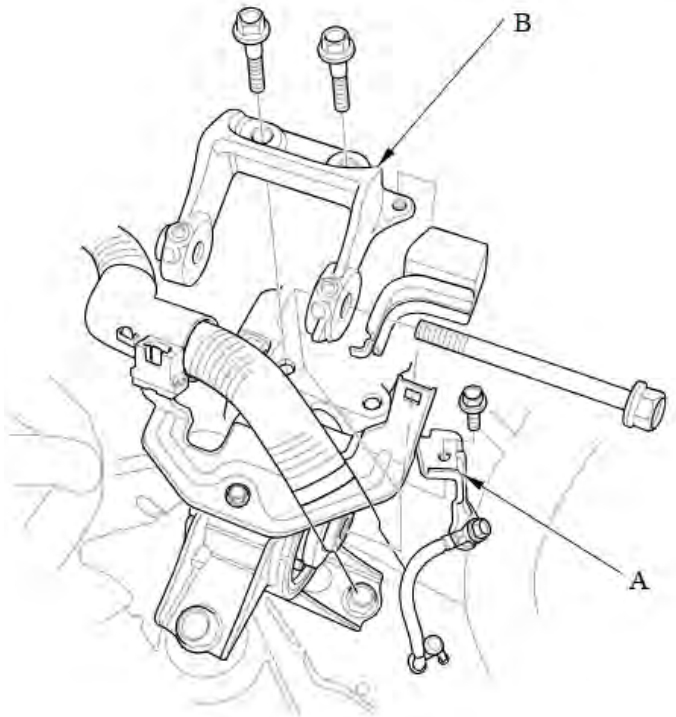

31. Remove the front upper timing cover (A) and the rear upper timing cover (B).

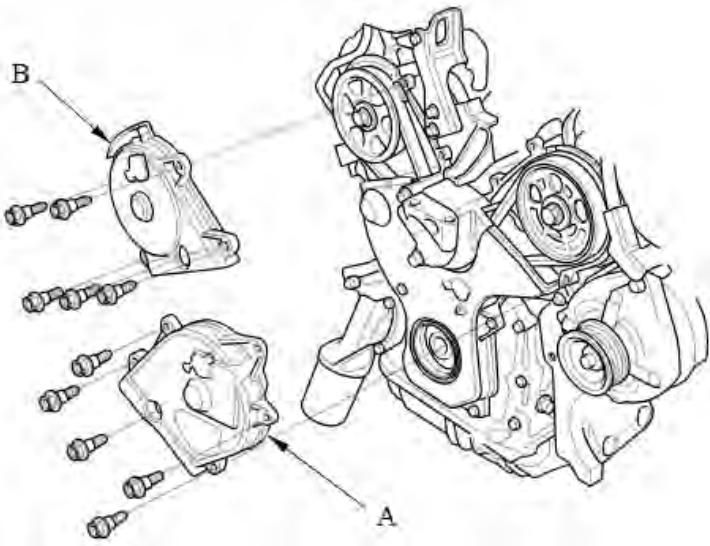

32. Raise the vehicle.

- 33. Remove the crankshaft pulley.
- 34. Remove the lower timing cover.

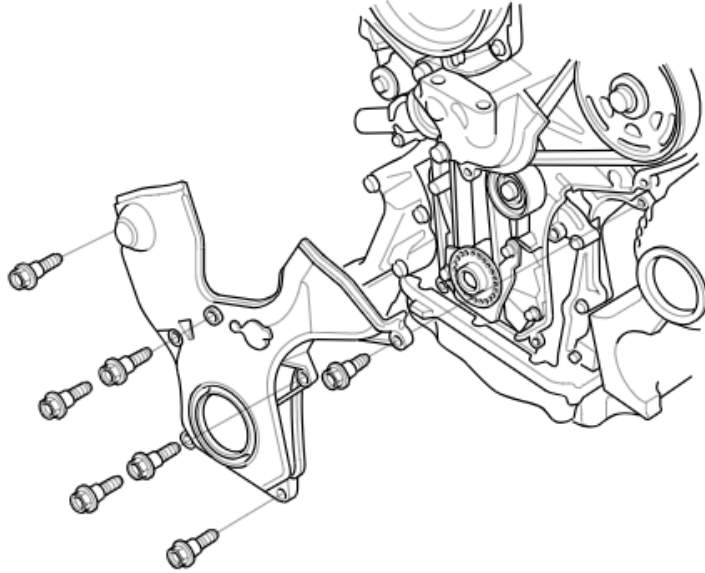

- 35. Lower the vehicle.
- 36. Remove the lower half of the side engine mount bracket.

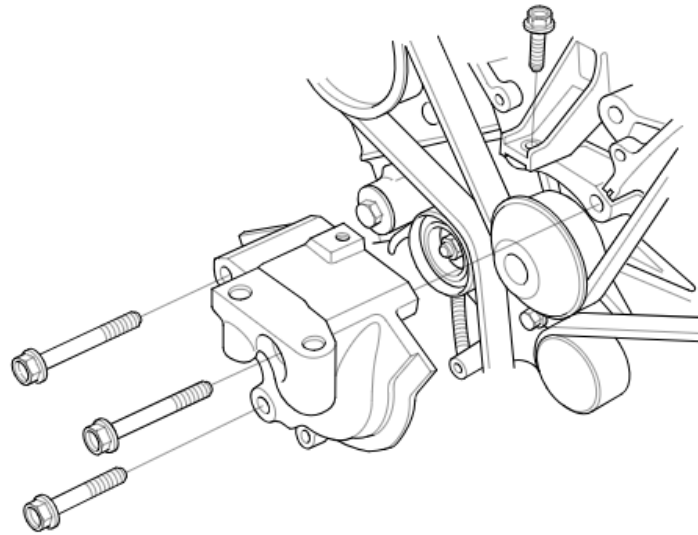

37. Remove the timing belt auto-tensioner.

NOTE: See the service manual for the procedure to compress the tensioner for installation.

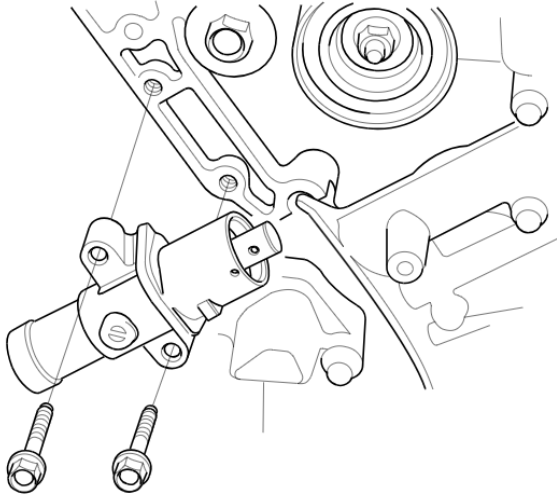

38. Remove the timing belt.

39. Depending on the diagnosis, remove some or all of the following:

- ECT sensor 1 connector
- Front rocker arm oil pressure switch connector
- Rear rocker arm oil pressure switch connector
- CMP sensor connector
- Front A/F sensor 1 connector
- Rear A/F sensor 1 connector
- Front secondary HO2S connector
- Rear secondary HO2S connector
- Rocker arm oil control solenoid A connector (bank one)
- Rocker arm oil control solenoid A connector (bank two)
- Rocker arm oil control solenoid B connector (bank one)
- Knock sensor connector

40. Remove the quick-connect fitting cover (A), then disconnect the fuel feed hose (B).

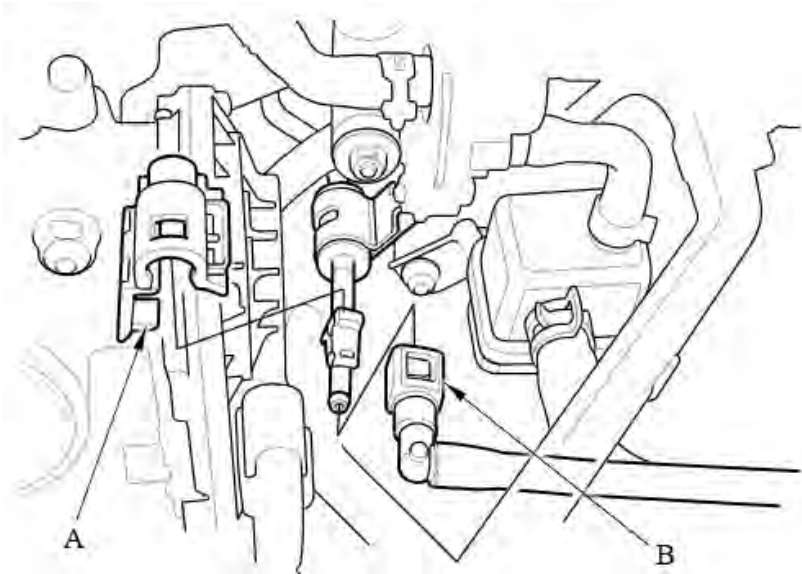

41. Remove the EVAP canister purge joint with the bracket.

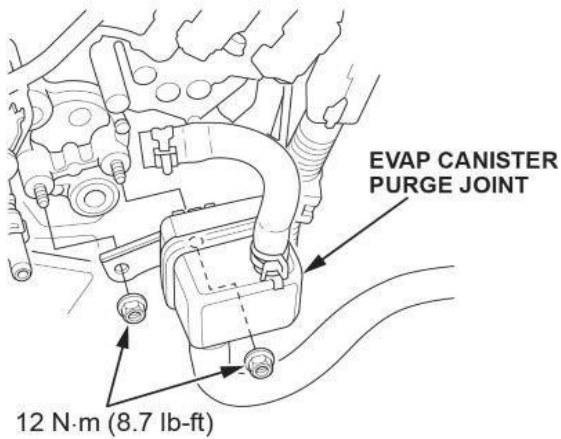

42. Remove the fuel rail connecting joint hose.

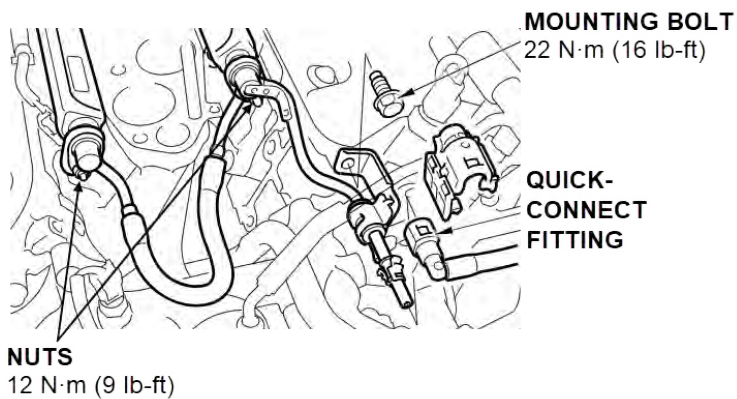

43. Remove the EGR pipe upper mounting bolts (A), then remove the EGR pipe.

NOTE: Use new gaskets on installation.

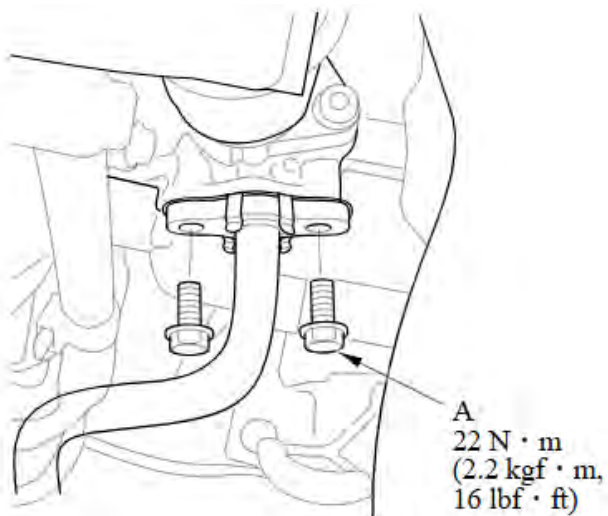

44. Remove the upper radiator hose (A) and the lower radiator hose (B).

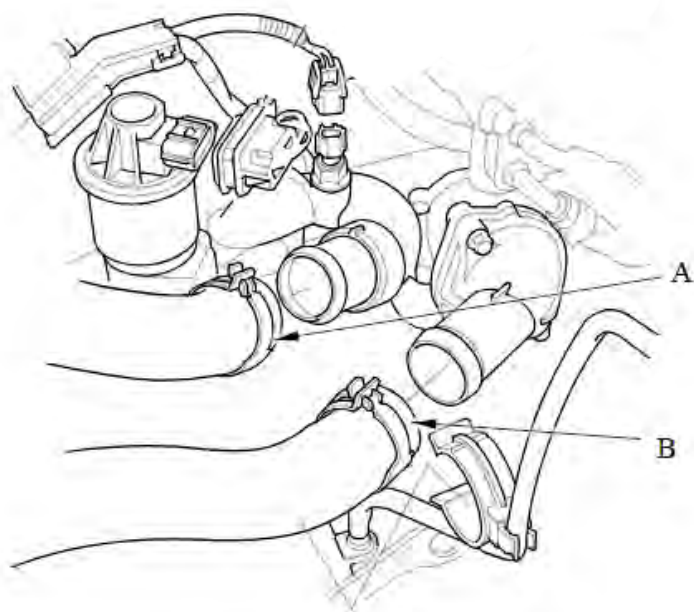

45. Separate the water passage from the cylinder heads, then remove the water passage assembly.

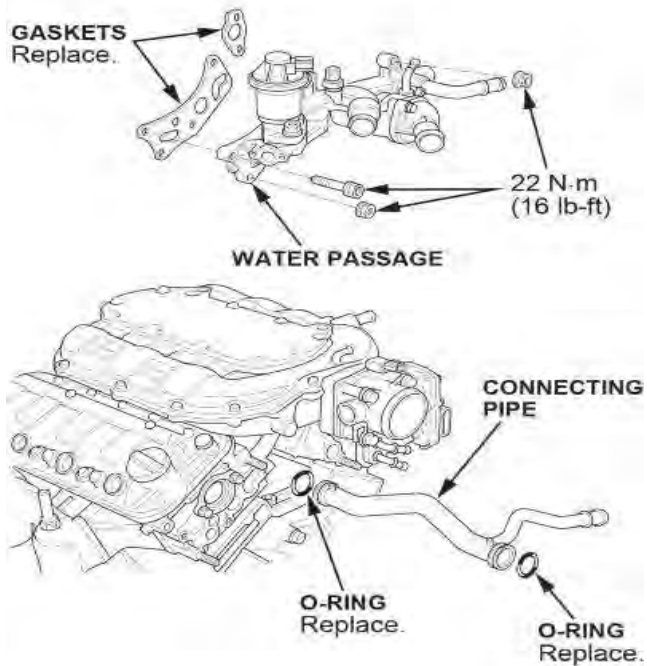

46. Remove the starter by removing the harness clamp (A), then disconnect the positive starter cable (B) and the S terminal connector (C) from the starter. Remove the lower radiator hose bracket (D) and the dipstick (E), then remove the starter assembly (F).

NOTE: Install with a new gasket (G).

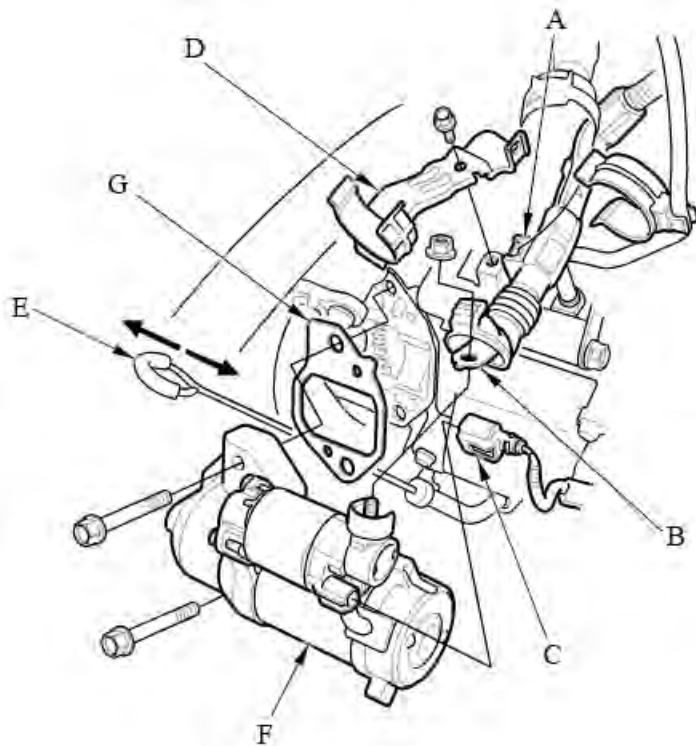

47. Unbolt the appropriate WU-TWC(s) from the cylinder head(s) based on the diagnosis.

NOTE: The WU-TWC can be set aside. Cover the opening with shop towels to prevent coolant from entering.

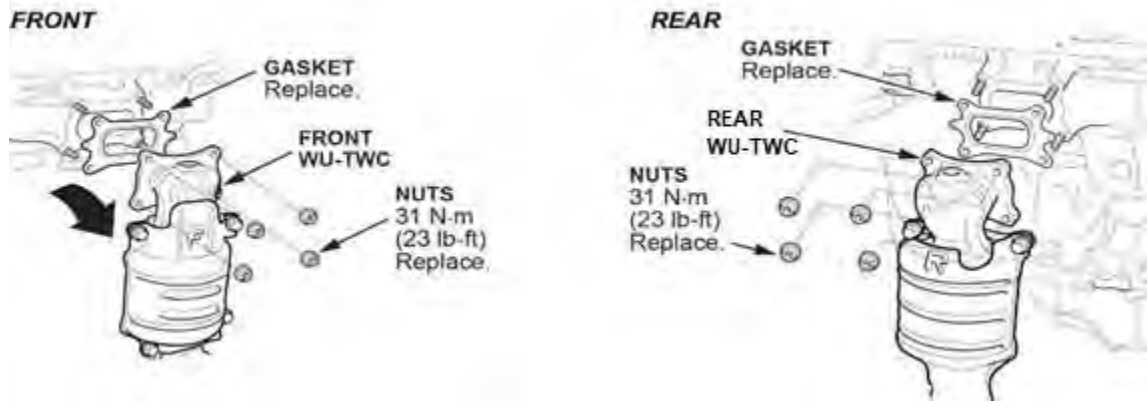

48. Remove the appropriate cylinder head(s) with the injector base attached.

NOTE:

- Depending on diagnosis, you will remove the rear bank cylinder head or both cylinder heads.
- To prevent warpage, loosen the bolts in sequence, **1/3 turn** at a time, repeat until all the bolts are loosened.

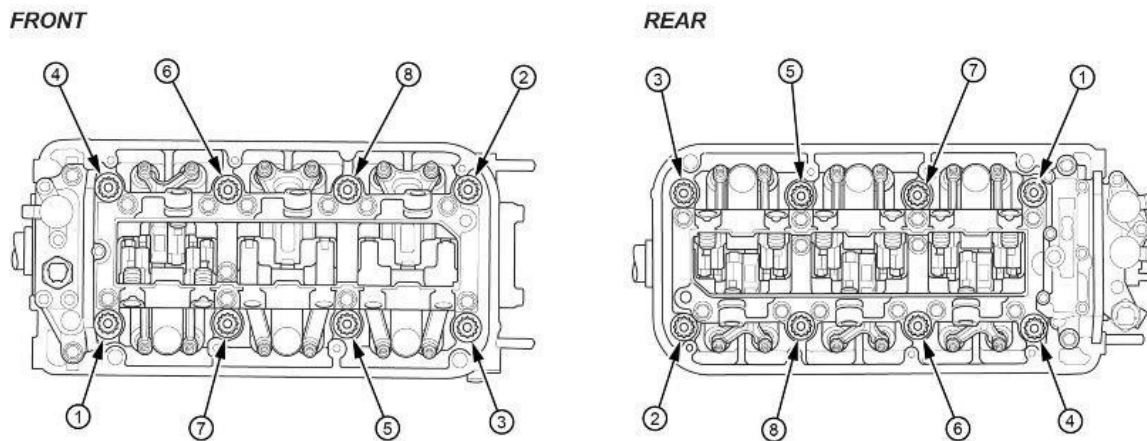

49. Measure the head bolts to determine if they need replacement. If either diameter is less than **11.3 mm (0.445 in.)**, replace the cylinder head bolt.

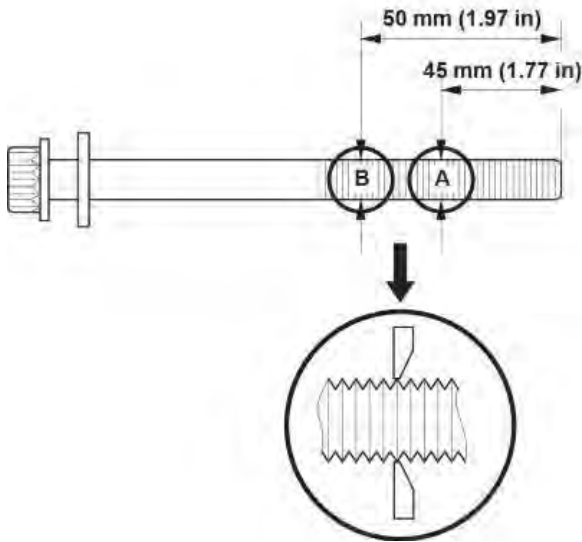

50. Use the cylinder wall inspection tool to inspect the cylinder walls for vertical scratching.

NOTE:

- For information on using the cylinder wall inspection tool, refer to the Job Aid "Cylinder Wall Inspection Tool" and/or *Tech2Tech* "Check out the Cylinder Wall Inspection Tool".
- **Do not** use a fingernail or pencil lead to determine if an engine block is usable. Light to moderate scratches that are detected with your fingernail will pass the inspection when using the cylinder wall inspection tool.

[Check Out the Cylinder Wall Inspection Tool](#)

**Cylinder Wall Inspection Tool (07AAJ-R70A301)**



51. Determine the repair direction based on the cylinder inspection:

DTCs Stored	Cylinder Bore Condition?	Repair Direction
P0301, P0302, or P0303	No scratching or scoring detected	<b>Do Repair Procedure A:</b> <ul style="list-style-type: none"> <li>• Clean pistons 1-3</li> <li>• Replace piston rings 1-3</li> <li>• Replace spark plugs 1-4</li> <li>• Update PCM software</li> </ul>
	Scratching or scoring detected	<b>Do <a href="#">Repair Procedure B</a>:</b> <ul style="list-style-type: none"> <li>• <b>Remove front cylinder head</b> (follow the steps above to remove the front cylinder head, then proceed to Repair Procedure B)</li> <li>• Replace short block</li> <li>• Replace spark plugs 1-4</li> <li>• Update PCM software</li> </ul>
P0304	No scratching or scoring detected	<b>Do Repair Procedure A:</b> <ul style="list-style-type: none"> <li>• Clean pistons 1-4</li> <li>• Replace piston rings 1-4</li> <li>• Replace spark plugs 1-4</li> <li>• Update PCM software</li> </ul>
	Scratching or scoring detected	<b>Do <a href="#">Repair Procedure B</a>:</b> <ul style="list-style-type: none"> <li>• Replace short block</li> <li>• Replace spark plugs 1-4</li> <li>• Update PCM software</li> </ul>

## REPAIR PROCEDURE A

### Piston removal, Cleaning, and Ring Replacement

1. Raise the vehicle.
2. Remove the CKP sensor cover and bolts, then disconnect the CKP sensor connector.

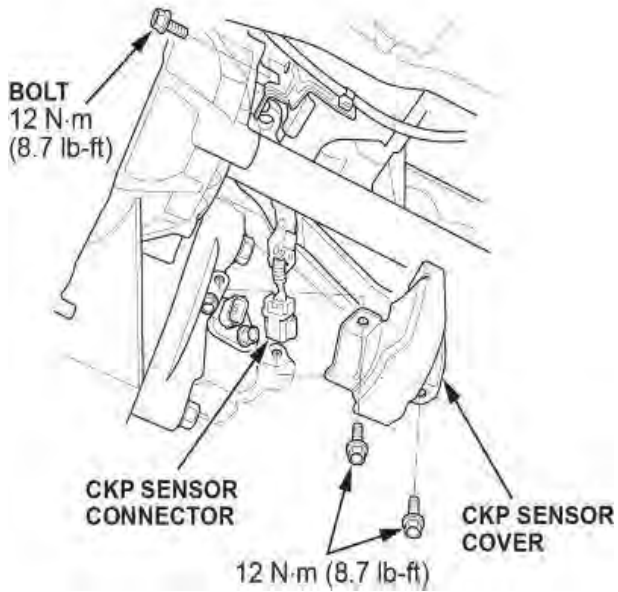

3. Remove the torque converter case cover and the four bolts securing the oil pan to the transmission.

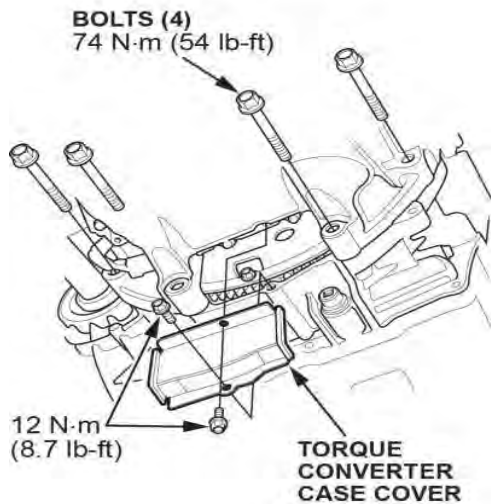

4. Remove all bolts securing the oil pan.

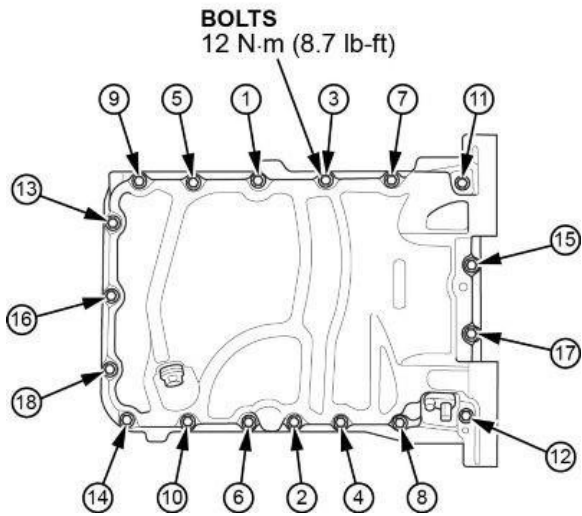

5. Using a flat blade screwdriver, separate the oil pan from the engine block in the areas shown.

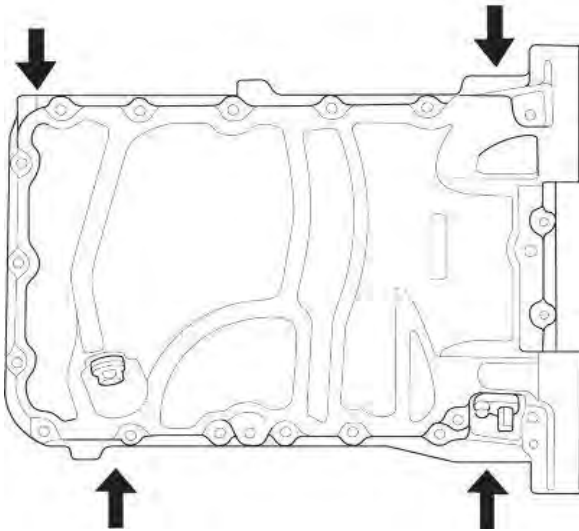

6. Remove the oil strainer and baffle plate.

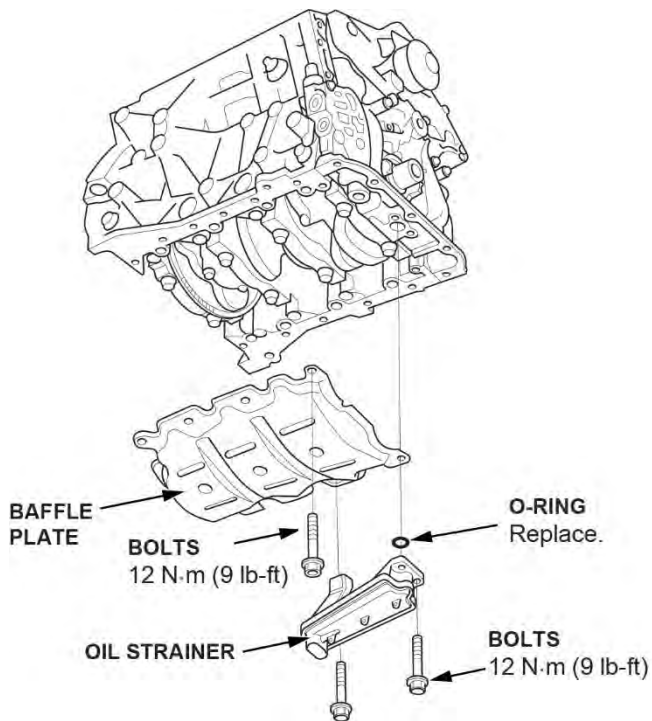

7. Remove the appropriate piston(s) depending on diagnosis.

**NOTICE**

**Installing a rod cap incorrectly will result in engine knock and/or engine failure. Remove and mark one rod assembly at a time to make sure it is assembled correctly.**

**NOTE:**

- **Before** removing the rod caps, use a grease pencil or suitable marking pen to mark each cap and its corresponding connecting rod with the cylinder number it came from.
- Do not confuse the existing marking on the side of the connecting rod and rod cap with a cylinder number. They are just manufacturing marks referring to the size of the big end of the rod.
- When torquing the rod cap bolts, refer to the service manual for details.

Click the link to go to the Tech2Tech® video "[Tips When Working with Fracture Rods](#)".

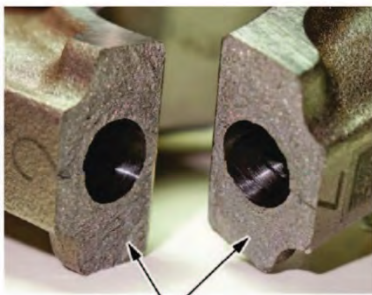

## Piston Cleaning and Ring Replacement

1. Remove the piston rings from the piston using a ring expander. Be careful not to damage the piston.

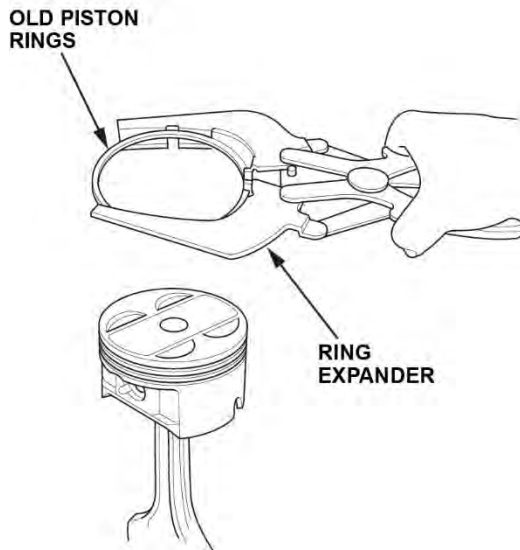

2. Spray the piston head and piston ring grooves thoroughly with Honda throttle plate cleaner.
3. While holding the piston upright in one hand, take the piston ring groove cleaner tool in the other hand and line up the cleaner tool guides with the second (middle) piston ring groove.



4. Press the handle on the piston ring groove cleaner tool and slide the cleaning bit so it engages all 3 piston ring grooves.

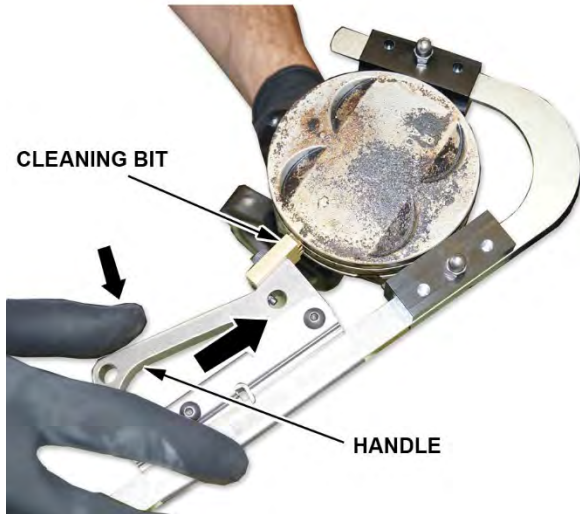

5. Once the cleaning bit is in the appropriate ring grooves of the piston, make sure the tool handle clicks into place.  
NOTE: There is only one notch on the tool for the handle to engage.

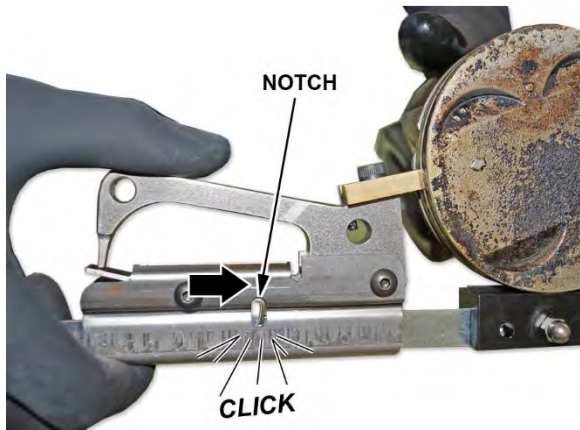

6. Hold the piston steady and rotate the tool counterclockwise five to six times to remove any carbon deposits in the piston ring grooves. **Do not** rotate the tool clockwise.

NOTE: You can watch this procedure in the *Tech2Tech* segment ["How to Clean Piston Ring Grooves"](#).

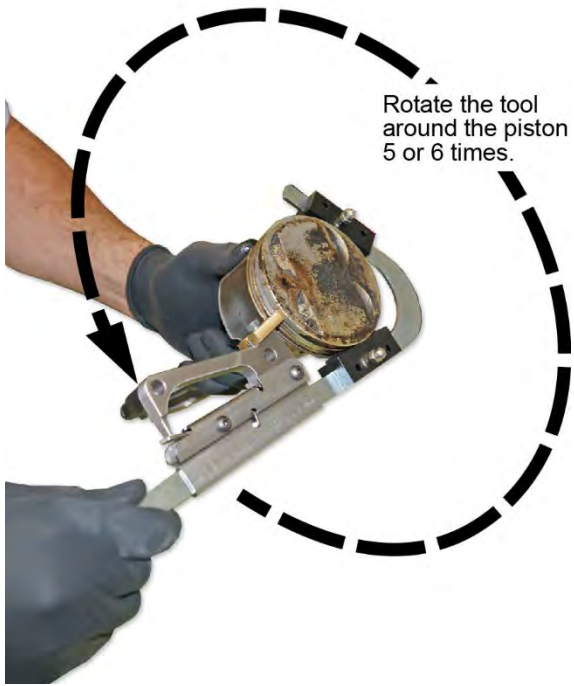

7. Remove the piston groove cleaning tool and clean off the carbon from the tool bit.

8. Finish cleaning the piston with throttle plate cleaner and the nylon brush. **Do not** use a steel wire brush.



NOTE: Below are some examples of before and after pictures. Depending on mileage and running conditions, the pistons will achieve different levels of cleanliness.

54K PISTON



87K PISTON



9. Install the piston rings as shown.

NOTE: The first (top) ring has a 1R manufacturing mark and the second (middle) ring has a SPR manufacturing mark. The manufacturing marks must be facing upward.

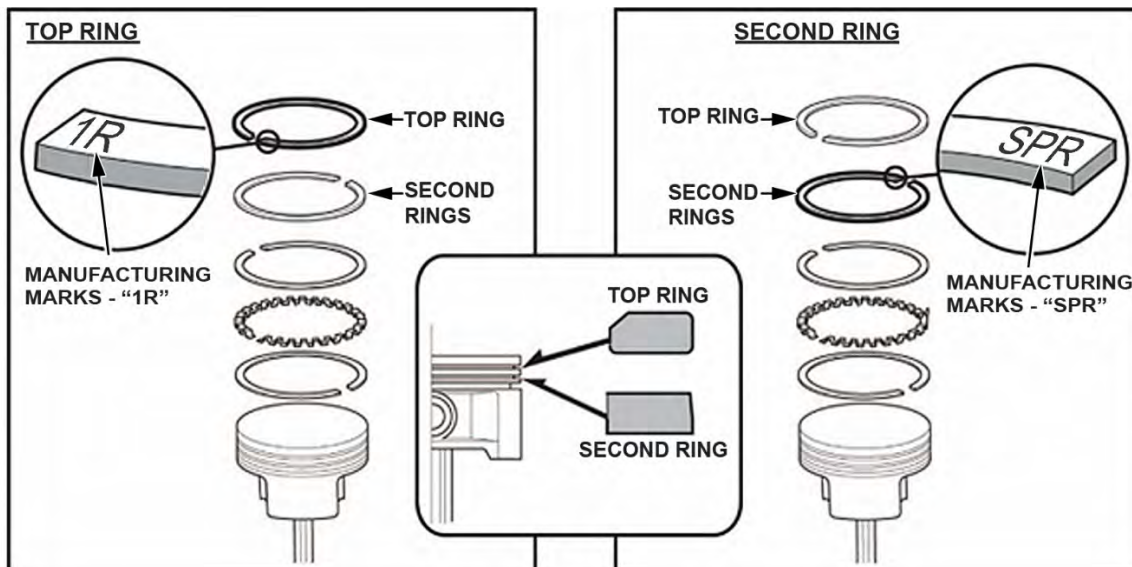

10. Rotate the rings in their grooves, make sure the rings do not bind.

11. Position the ring end gaps as shown.

NOTE: If the ring gaps are not positioned correctly, excessive blowby may occur.

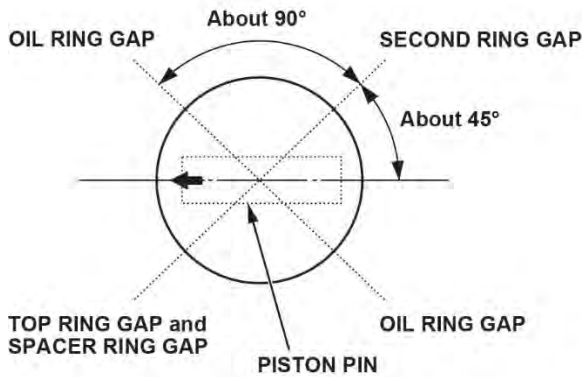

12. Apply new engine oil to the piston, the inside of the piston ring compressor, and the cylinder bore.

NOTE: **Cylinder wall honing is NOT required for this repair.**

13. Install the piston/connecting rod assembly into the cylinder bore with the arrow on top of the piston facing the timing belt side of the engine.

NOTICE

Be careful not to damage the cylinder wall when installing the piston.

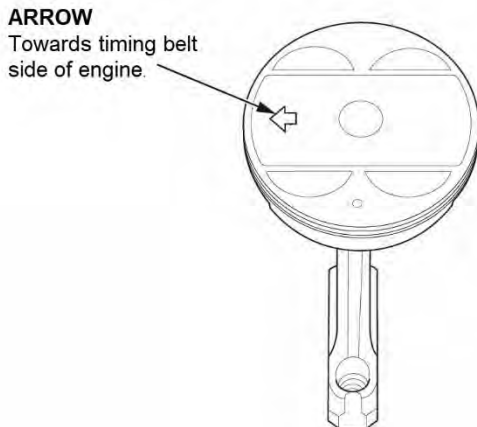

14. Set the piston in the ring compressor and position the piston in the cylinder based on the rod/cap marks that were made during disassembly.

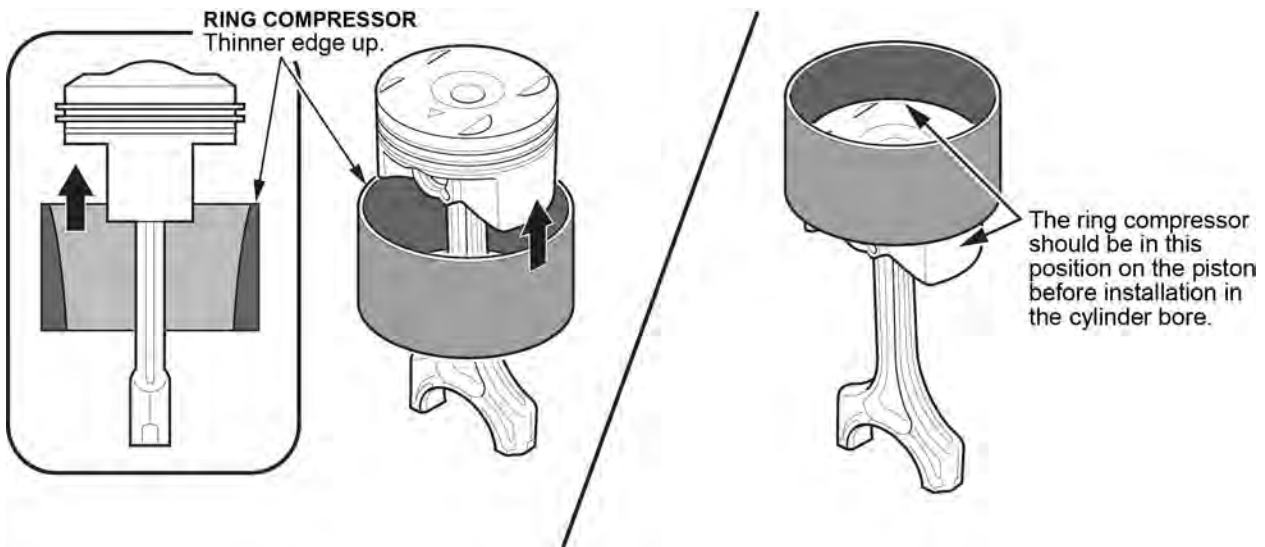

15. Set the ring compressor on the piston bore, then push the piston in with your hands.

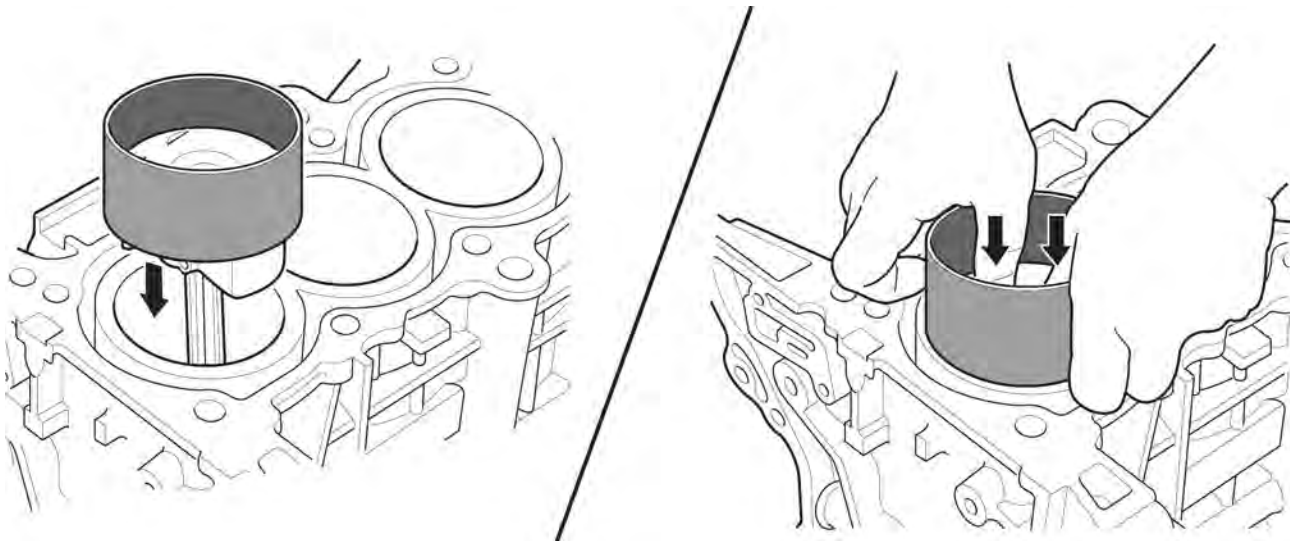

16. Stop after the ring compressor pops free and check the connecting rod-to-rod journal alignment before pushing the piston into place.

17. Measure the diameter of the connecting rod bolts to determine if they need replacement. Calculate the difference in diameter between point A and point B. It should not be more than **0–0.1 mm (0–0.004 in)**. Any bolts exceeding specification should be replaced.

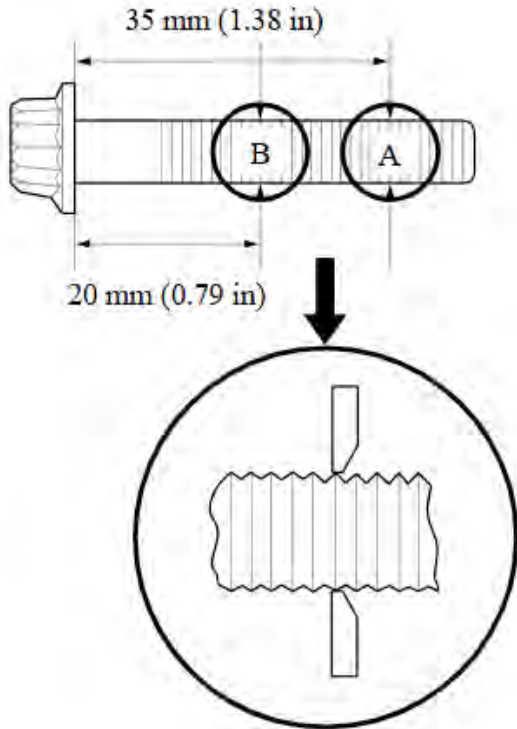

18. Install the connecting rod cap and bearing by applying new oil to the connecting rod bolt threads and flanges. Torque the connecting rod cap bolts to **20 N•m (14 lb-ft)**, then tighten the bolts an additional quarter turn (**90 degrees**).

**NOTICE**

**Do not** mix up the connecting rod caps. [See March 2017 Service News.](#)

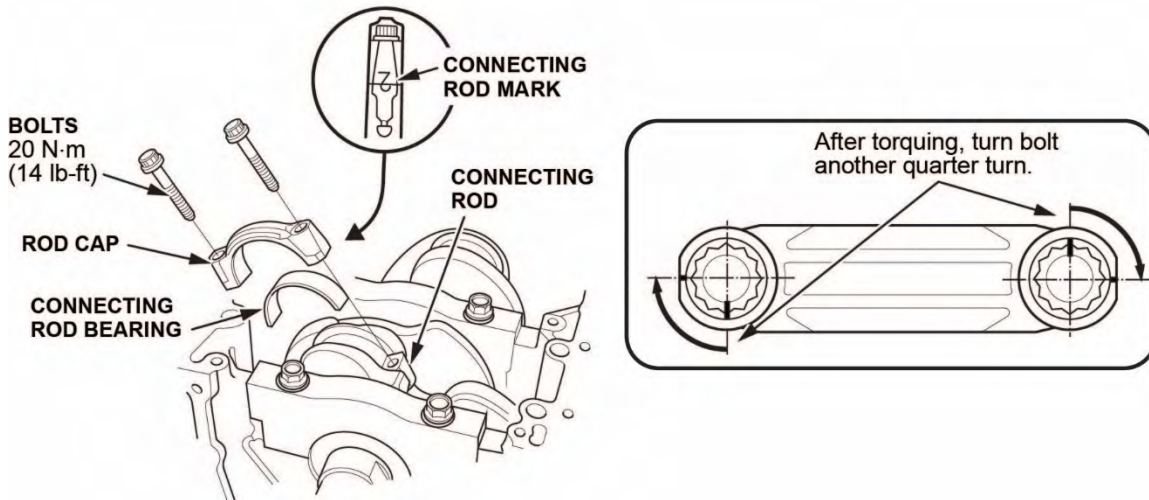

19. Install the baffle plate, then install the oil strainer with a new O-ring.

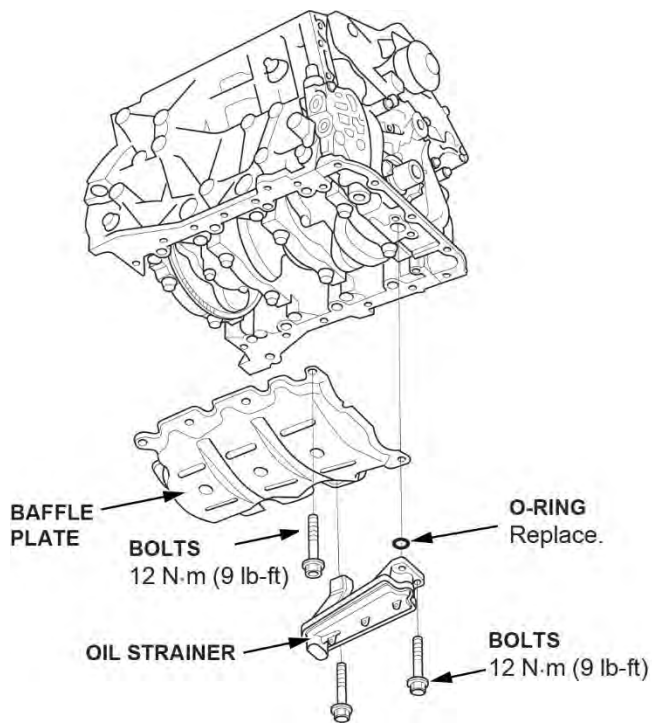

20. Install the oil pan and tighten the bolts in 3 steps. In the final step, tighten all bolts in sequence to 12 N·m (8.9 lb-ft).

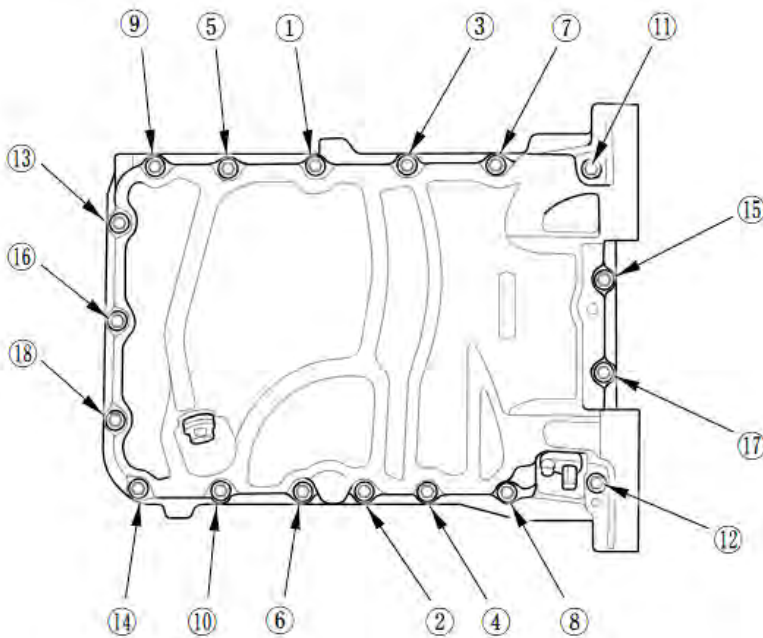

21. Lower the vehicle

22. Install the cylinder head(s).

NOTE: The crankshaft and camshafts should be set to TDC.

Steps for torquing the cylinder head bolts to specification:

1. Apply new engine oil to the threads and under the bolt heads.
2. Torque the cylinder bolts in sequence to **29 N·m (22 lb-ft)**.
3. Tighten in sequence an additional **90 degrees** (third step).
4. Tighten in sequence an additional **90 degrees** (fourth step).
5. **If the bolts are new**, tighten an additional **90 degrees**.

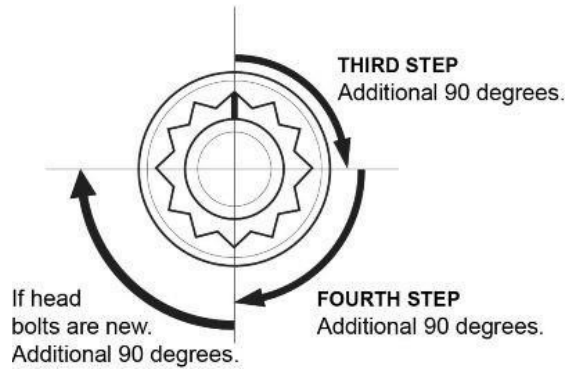

# Cylinder Head Bolt Installation Sequence

**Front**

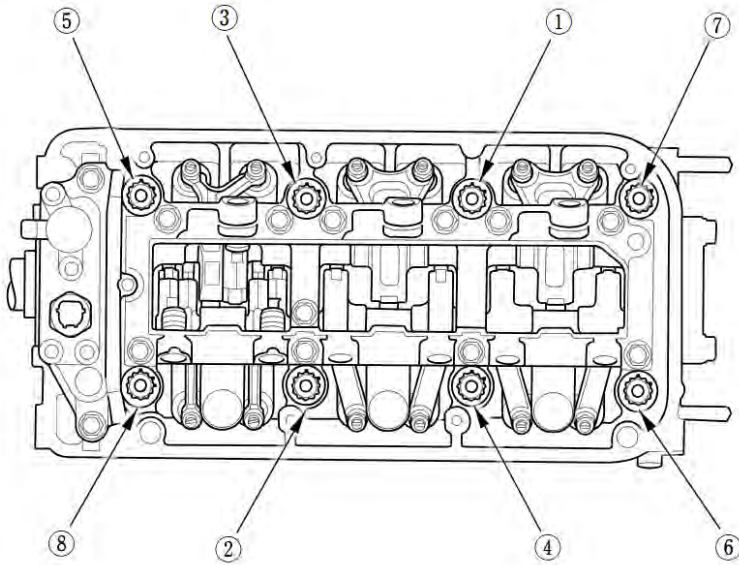

**Rear**

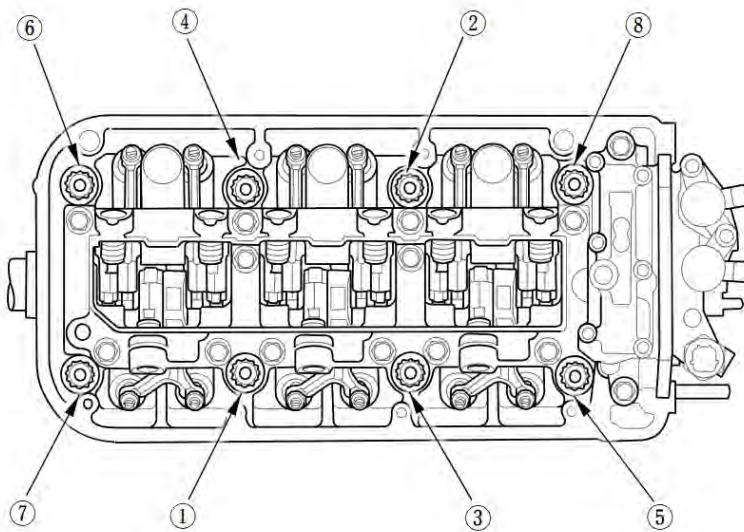

23. Install the catalytic converter(s).

**FRONT**

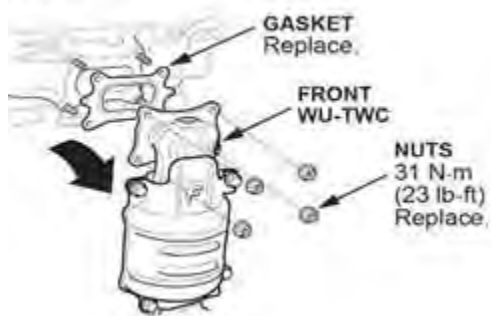

**REAR**

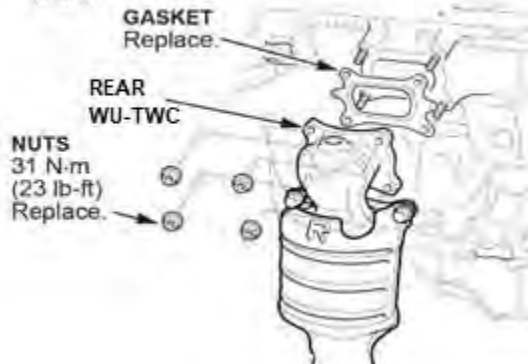

24. Install the timing belt auto-tensioner.

NOTE: Refer to the service manual for the procedure to compress the timing belt auto-tensioner before installation.

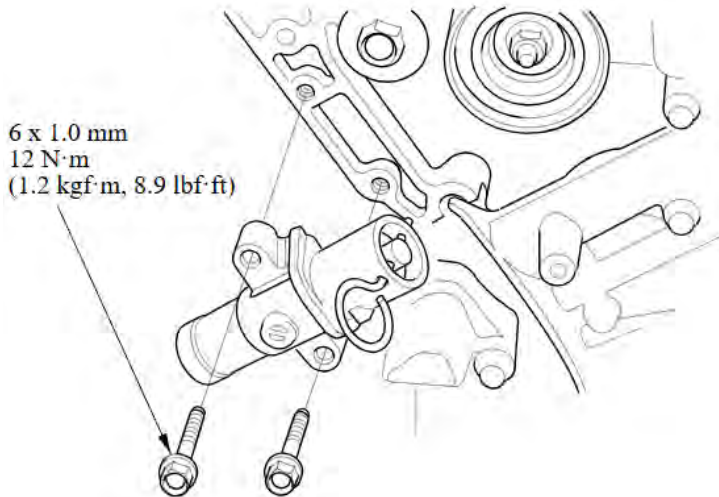

25. Install the timing belt.

NOTE: Refer to the service manual for the full procedure.

26. Tighten the idler pulley bolt to **45 N·m (33 lb·ft)**, then remove the pin from the auto-tensioner.

27. Install the lower half of the side engine mount bracket using new bolts (A) and (B).

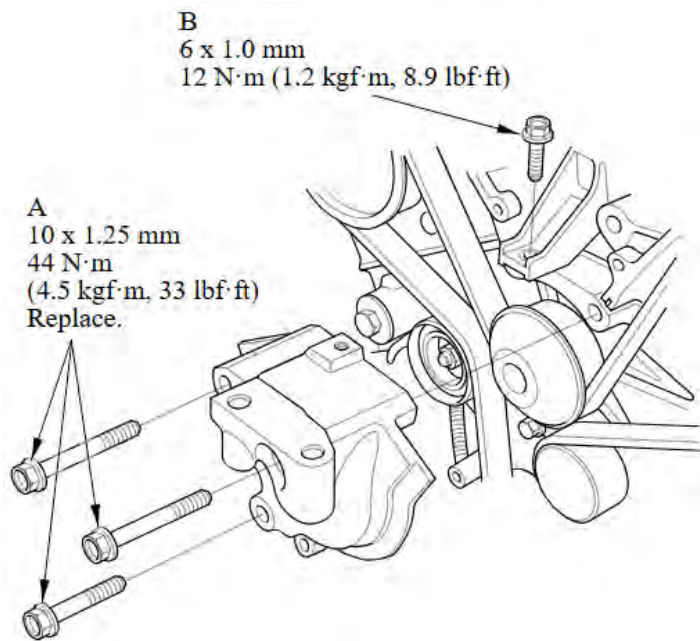

28. Raise the vehicle.

29. Install the lower timing cover and torque the mounting bolts to **12 N·m (8.9 lb-ft)**.

30. Install the crankshaft pulley.

1. Remove any oil and clean the pulleys (A), the crankshaft (B), the bolt (C), and the washer (D). Lubricate with new engine oil as shown.

- ✕ : Remove any oil
- : Clean
- : Lubricate with new engine oil

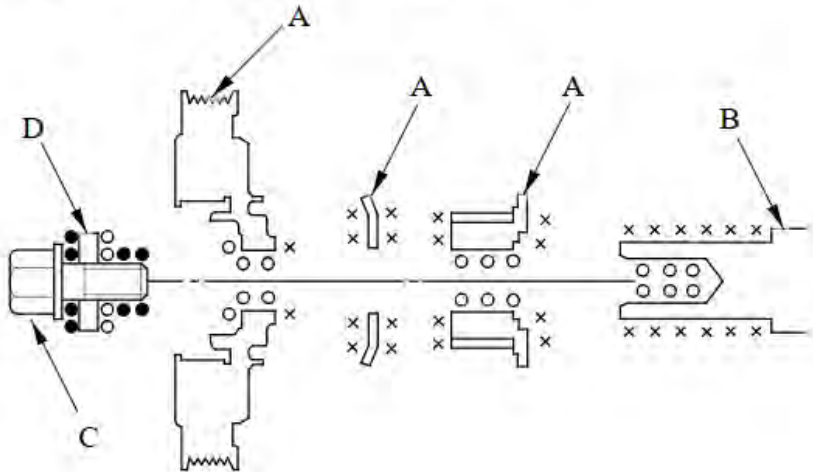

2. Install the crankshaft pulley and bolt.

- a. Hold the pulley with the handle (A) and the holder attachment (B). Torque the bolt to **65 N·m (48 lb-ft)**.
- b. Tighten the bolt an additional **60°**.

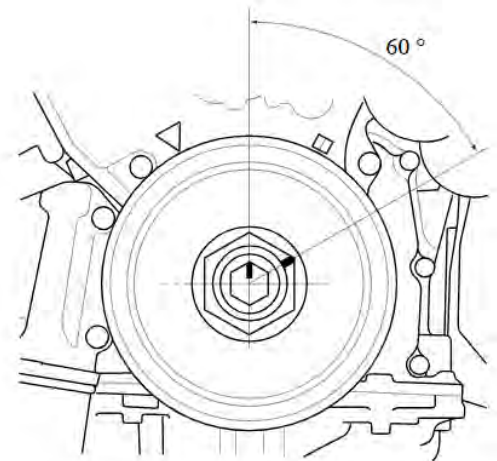
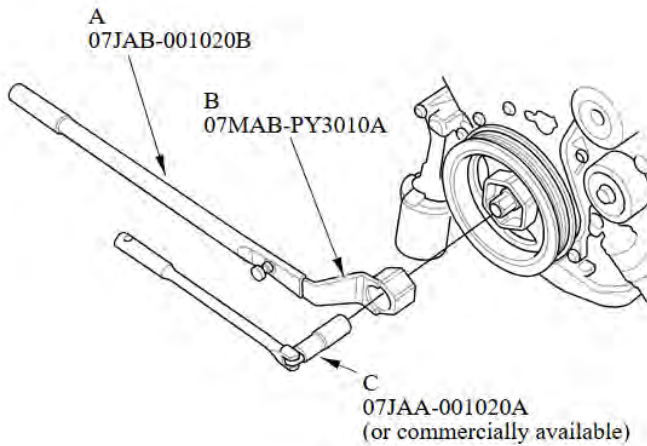

31. Install exhaust pipe A (A) with new gaskets (B) and nuts.

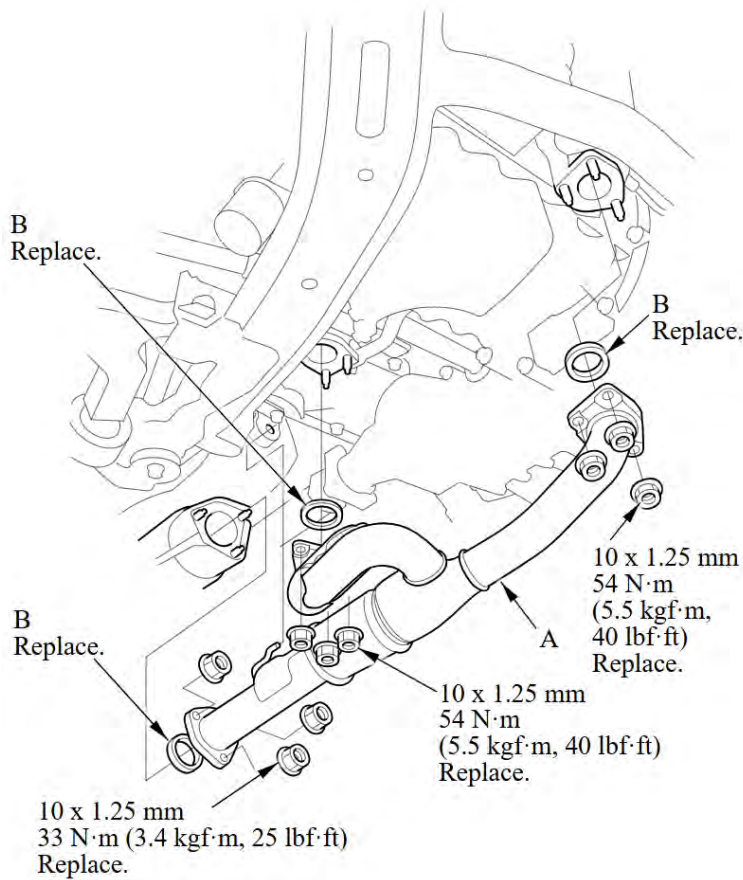

32. Adjust the valve clearance:

NOTE: Refer to the service manual for the full procedure.

**Valve Clearance**

<b>Intake</b>	0.20 - 0.24 mm (0.008 – 0.009 in)
<b>Exhaust</b>	0.28 - 0.32 mm (0.011 – 0.012 in)

REAR

FRONT

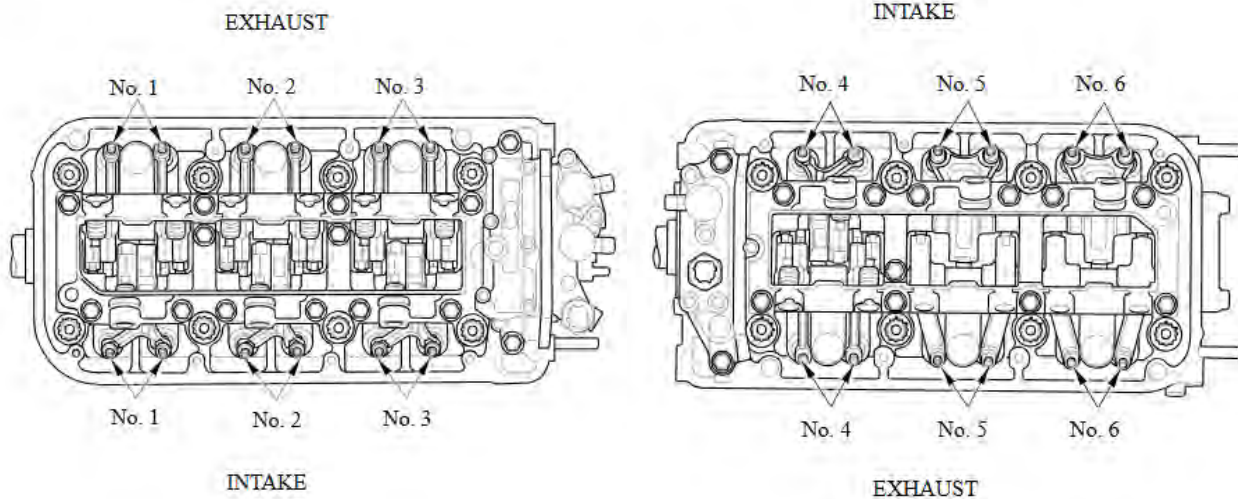

33. Install spark plugs 1-4.

34. Reinstall the remaining components in the reverse order of removal.

35. Replace the oil filter and refill all fluids.
36. Check the PCM software version P/N located above the PGM-FI Data List.

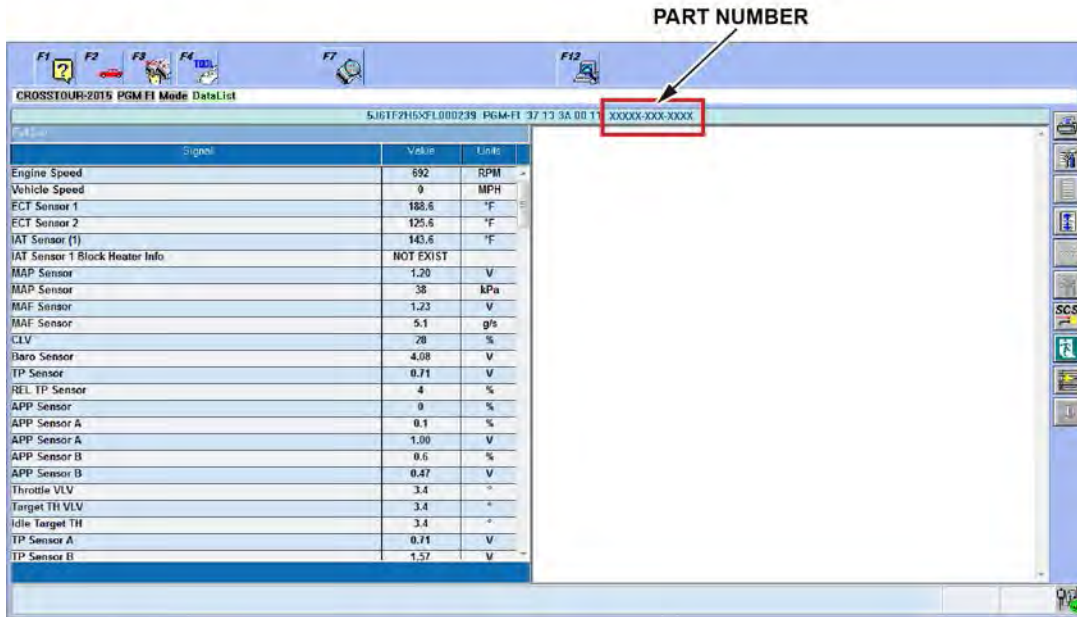

Year	Trim	Software System	New Program ID
2013–2014	Pilot (2WD)	PGM-FI	37805-RN0-M050
2013–2014	Pilot (4WD)	PGM-FI	37805-RN0-M950
2015	Pilot (2WD)	PGM-FI	37805-RN0-M140
2015	Pilot (4WD)	PGM-FI	37805-RN0-M840

37. Do the PCM update, if needed.  
 NOTE: For information on updating the PCM see service bulletin [22-100 Updating Control Units/Modules with the Honda ECU Reprogramming Application](#).  
 Is the PCM Program ID and/or Program P/N the same or newer than what is listed above?  
**NO** – The PCM software needs to be updated.  
**YES** – The correct software is installed.
38. Do the idle learn procedure.

## REPAIR PROCEDURE B

### Engine short Block Replacement

1. Remove the front cylinder head, if applicable, following the steps in the INSPECTION PROCEDURE.
2. Remove the steering joint bolt (A) to disconnect the steering column at the joint.

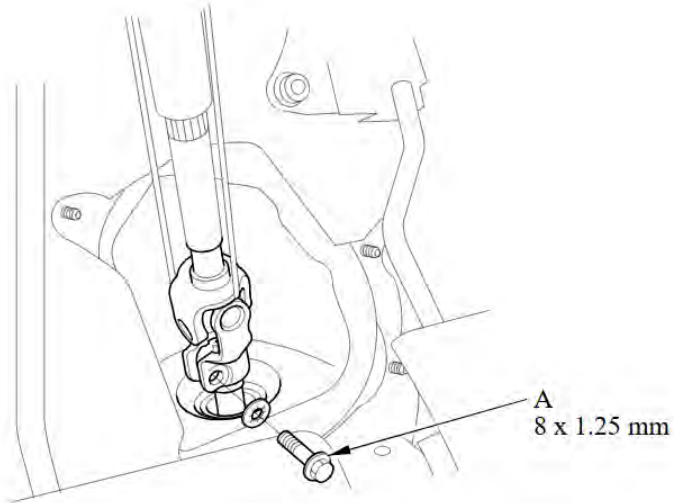

3. Remove the coolant connecting pipe.

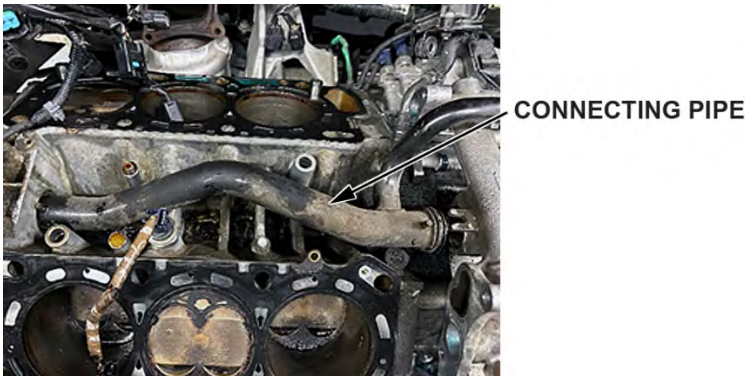

4. Remove the front and rear catalytic converters.

5. Remove the harness clamps (A), then disconnect the positive alternator cable (B) from the under-hood fuse/relay box.

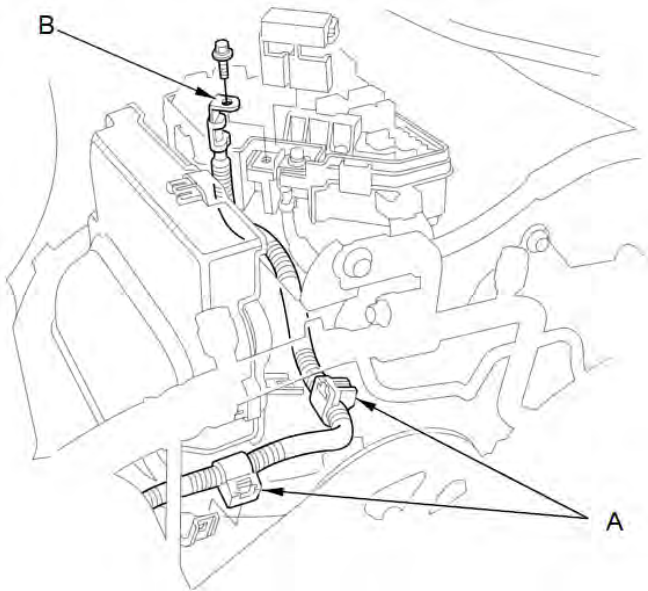

6. Remove the harness clamps (A), and the auxiliary under-hood fuse/relay box (B), then remove the battery base (C).

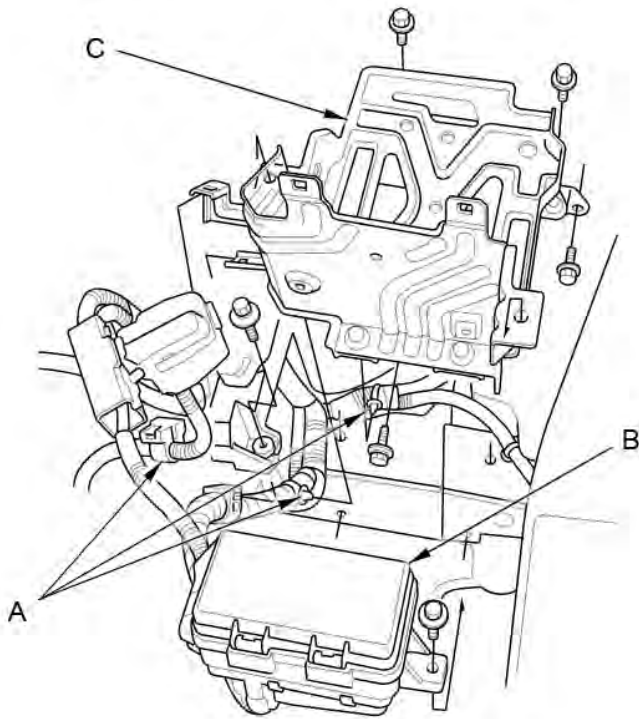

7. Disconnect the transmission shift cable.

NOTE: **If 4WD** – place shifter in neutral (N) before removing shift cable.

1. Remove the spring clip (F) and the control pin (E), then separate the shift cable end (A) from the selector control lever (D).
2. Remove the nuts securing the shift cable bracket (C).

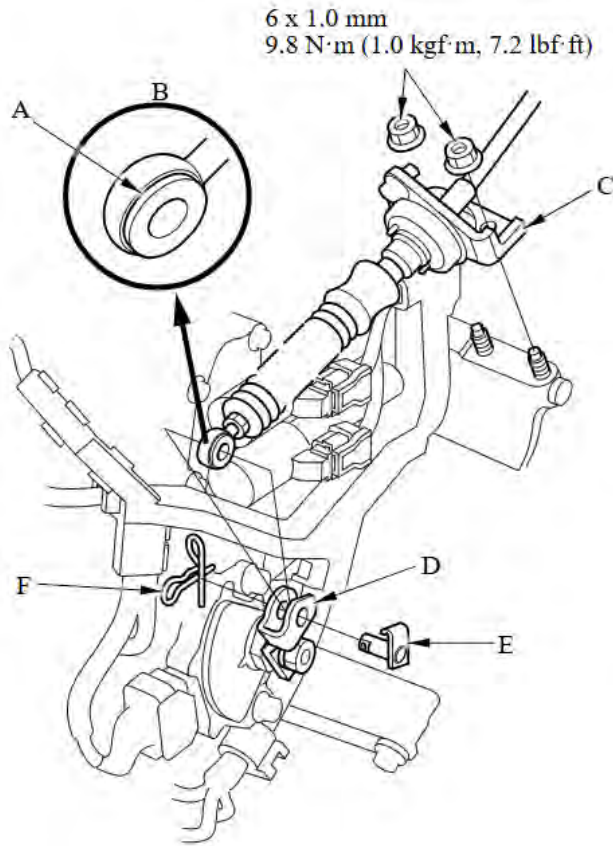

8. Disconnect the A/C compressor clutch connector (B), then remove the A/C compressor (A) **without** disconnecting the A/C hoses.

NOTE:

- **Do not** bend the A/C hoses excessively.
- Hang the A/C compressor from the fan shroud with a wire tie.

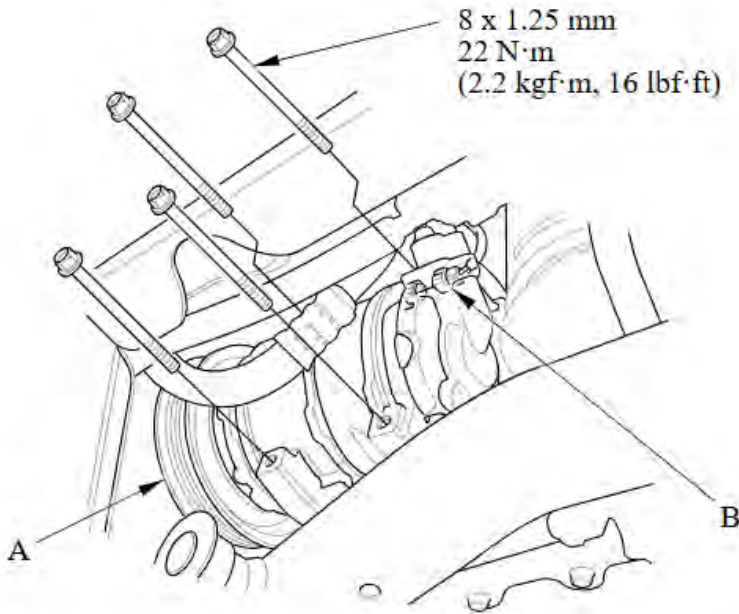

9. Remove power steering fluid from the reservoir (A) to prevent fluid leaks.

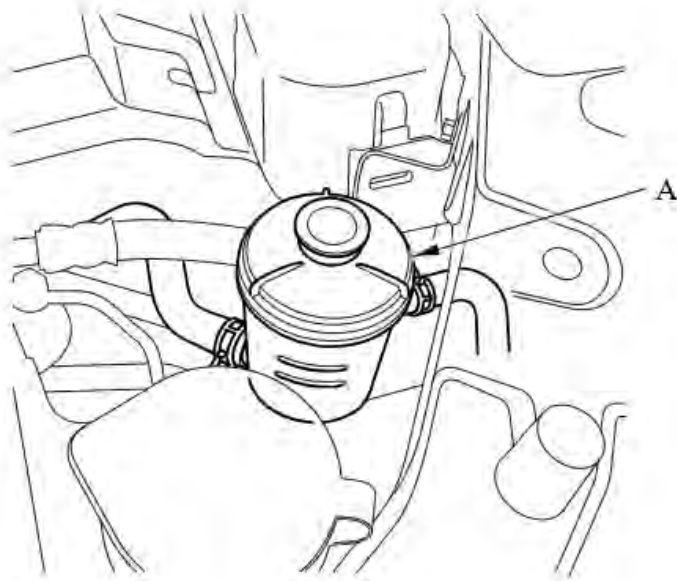

10. Disconnect the power steering pump inlet hose (C) and the power steering pump outlet hose (A) from the power steering pump, then plug the power steering hoses and the power steering pump. Power steering hose bracket (D) was removed earlier. Leave the power steering pump off to the side.

NOTE: Replace the seal (B) on reassembly and torque to specification.

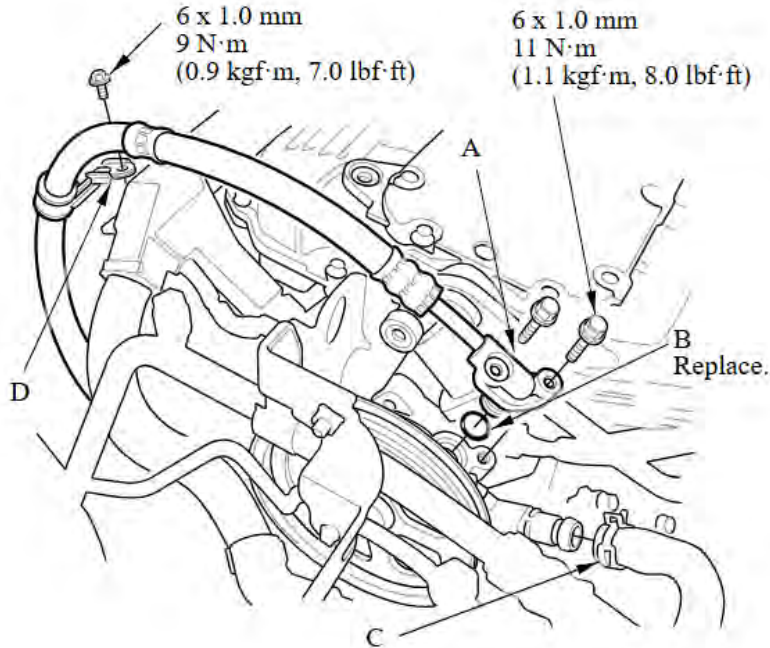

11. Lift the vehicle.
12. Drain the transmission fluid.

NOTE: Reinstall the drain bolt with a new sealing washer after draining the transmission fluid. Torque the drain bolt to **49 N·m (36 lb-ft)**.

13. **With VTM-4 Only** - Remove the transfer assembly.

NOTE: For non-VTM-4 vehicles, proceed to step 12.

1. Remove the drain plug (A) and drain the ATF. After the ATF has drained, reinstall the drain plug with a new sealing washer (B).

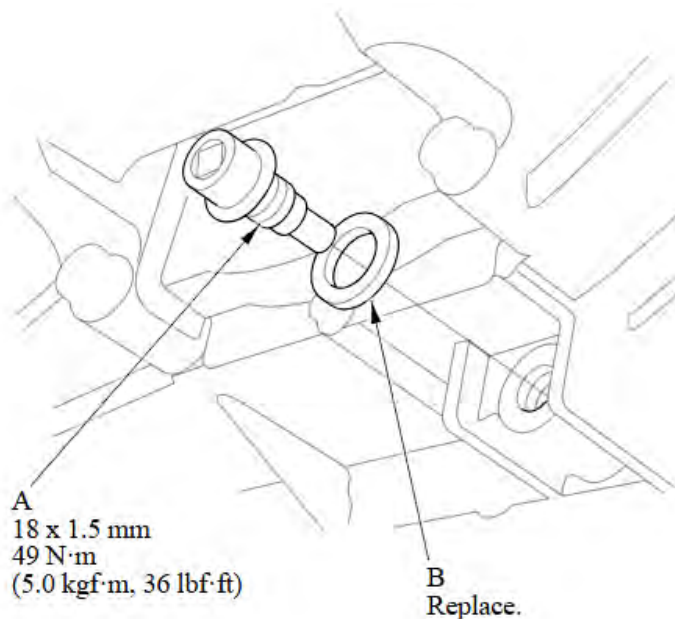

- Remove the bolt securing the transfer breather hose bracket (A) and disconnect the breather hose (B) from the breather pipe (C) on the transfer assembly.

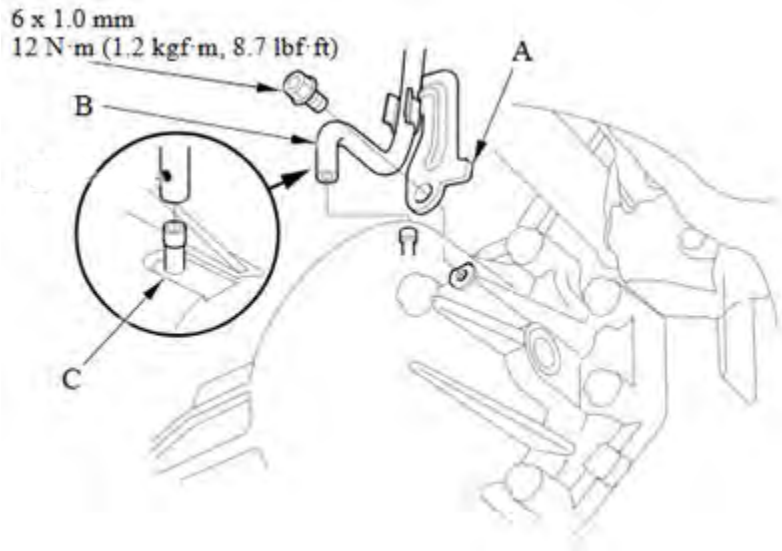

- Make a reference mark (A) across the propeller shaft (B) and the transfer companion flange (C).

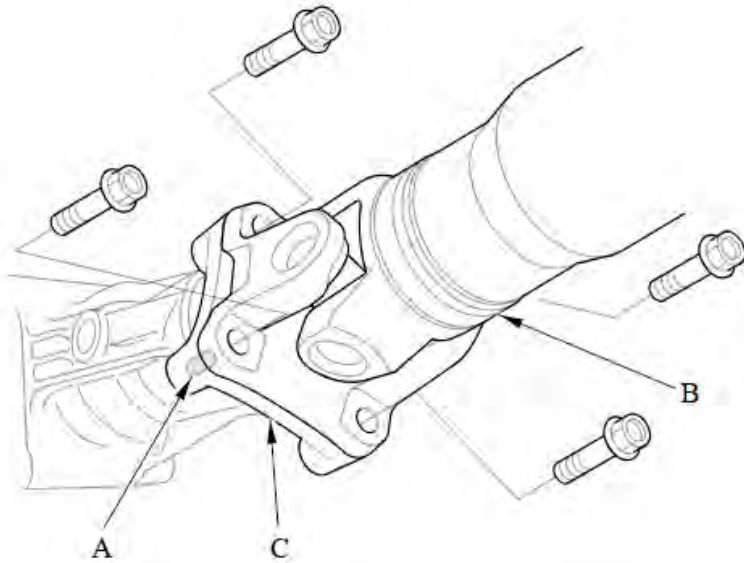

- Separate the propeller shaft from the transfer companion flange.

5. Remove the transfer assembly (A) and the dowel pin (B) from the transmission. Proceed to step 15.

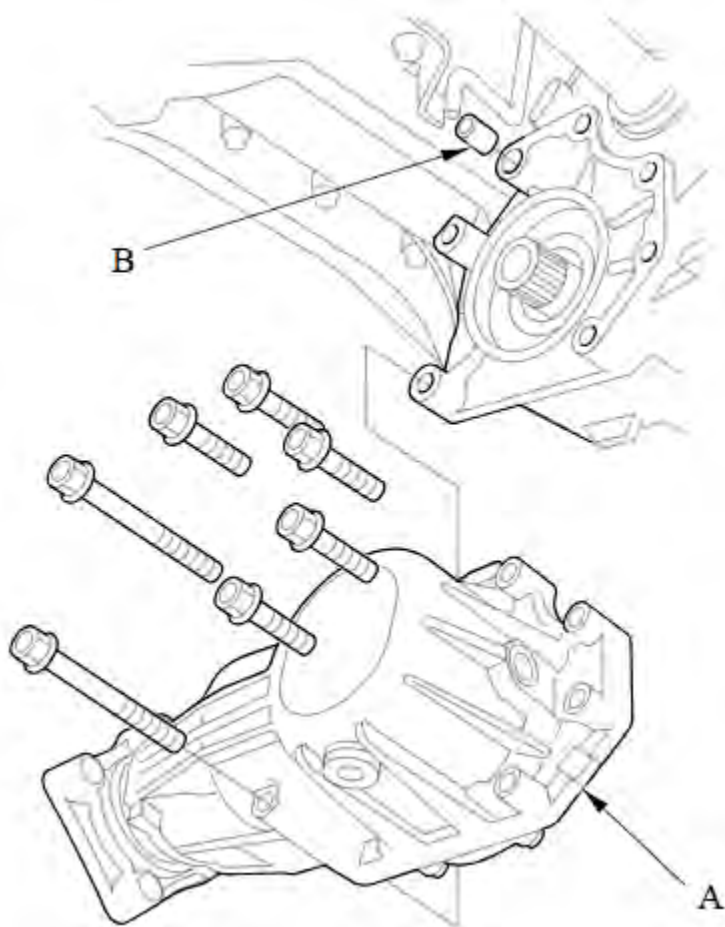

14. Remove the left fender liner.

15. Disconnect the power steering hose (A) and the ATF cooler hoses (B).

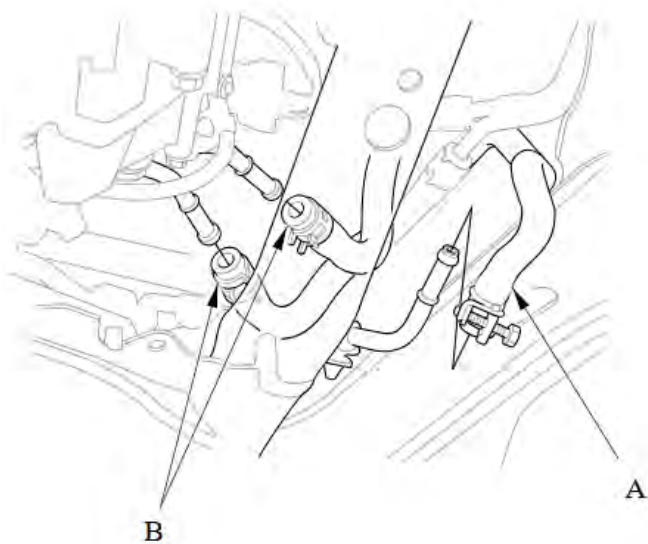

16. Remove the transmission ground (B).

6 x 1.0 mm  
12 N·m  
(1.2 kgf·m, 8.9 lbf·ft)

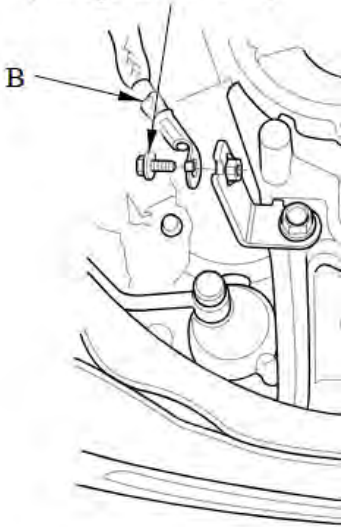

17. Remove the damper pinch bolts (A) and the flange nuts (B) from the damper. Repeat for both sides.

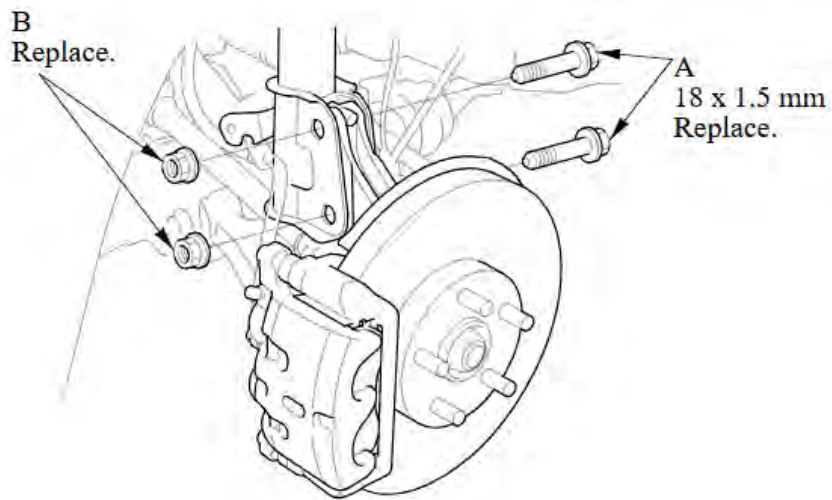

18. Remove the left side brake hose mounting bolt (A), then remove the caliper bracket mounting bolts (B) and remove the caliper (C) from the knuckle. Repeat for the right side.

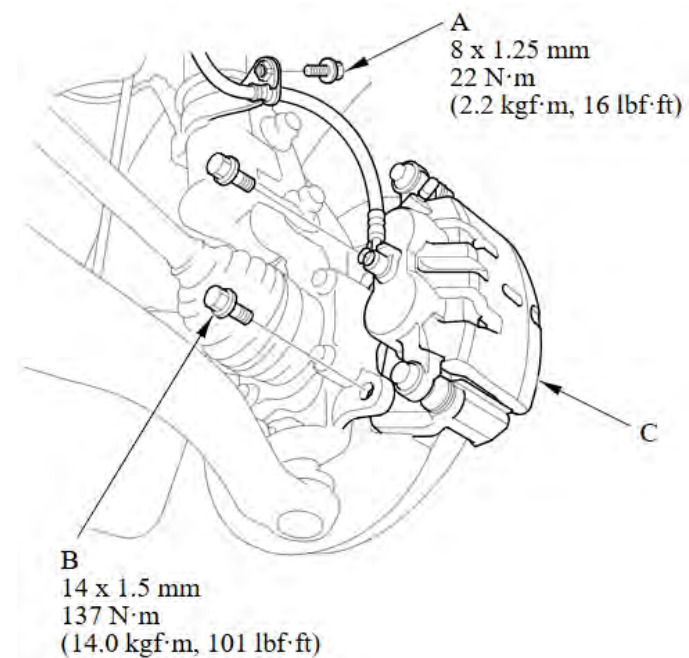

19. Remove the flange nut (C) while holding the joint pin (D) with a hex wrench and disconnect the upper stabilizer link (A) from the damper (B).

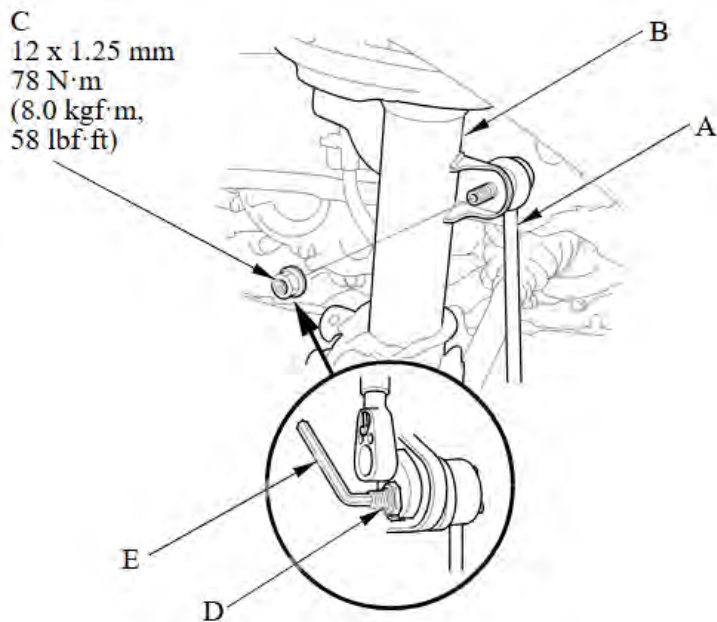

20. Remove the wheel speed sensors (A) from the knuckles (B). Repeat for both sides.

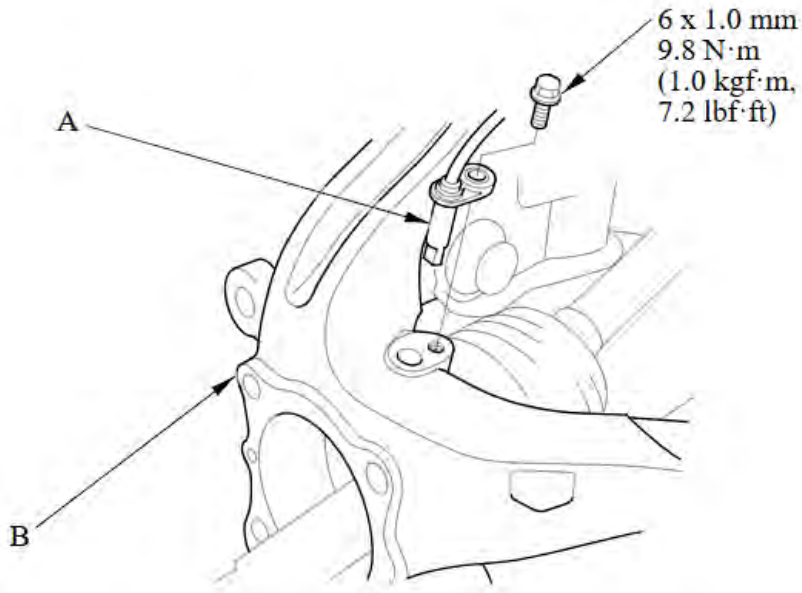

21. Disconnect the front and rear engine harness connector.

22. Disconnect the front engine mount actuator connector (A).

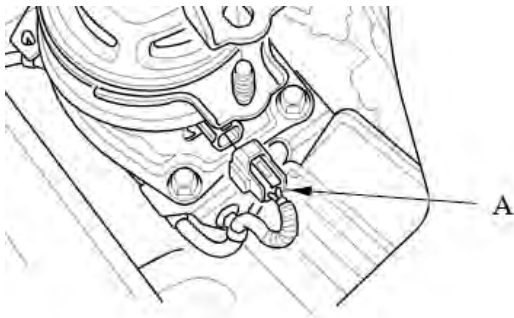

23. Disconnect the rear engine mount actuator connector (A).

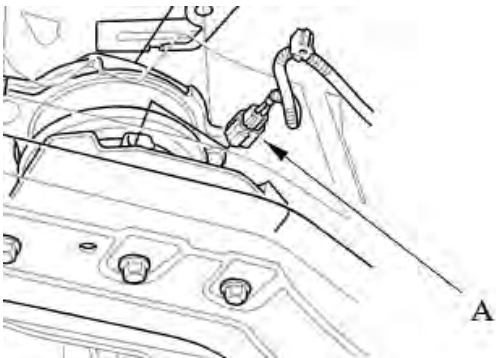

24. Remove the CKP sensor cover (A) and bolts, then disconnect the CKP sensor connector (B).

NOTE: Do not remove the CKP sensor at this time.

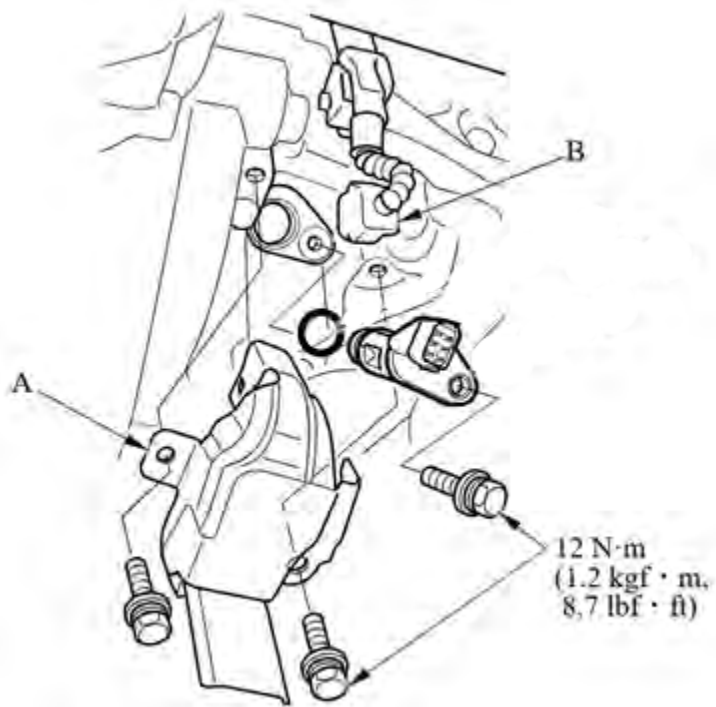

25. Disconnect the lower power steering pressure switch connector.

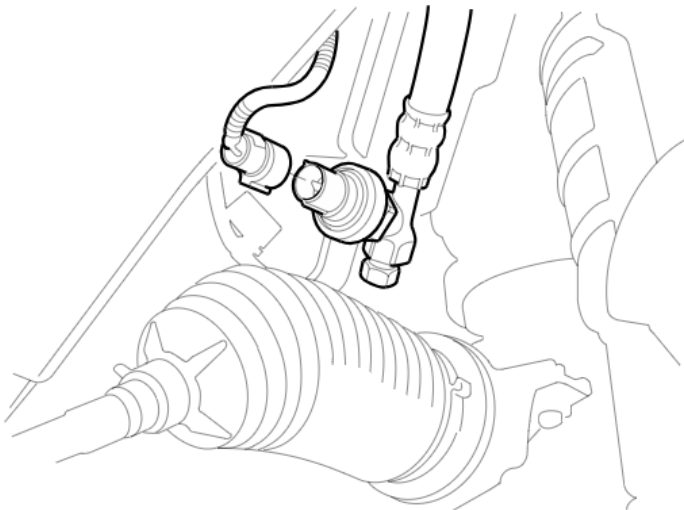

26. Loosely install crankshaft pulley bolt.

27. Remove the four bolts securing the oil pan to the transmission.

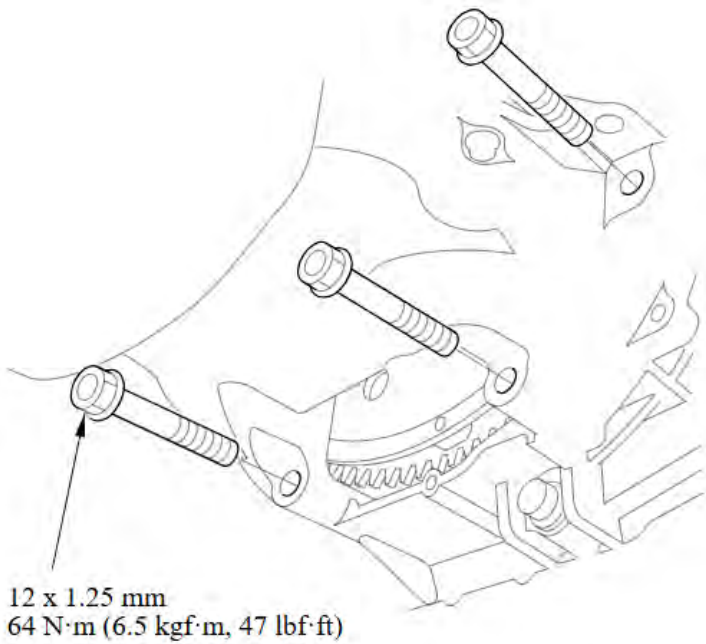

28. Remove the torque converter cover (C), then remove the eight bolts (B) that attach the drive plate (A) to the torque converter.

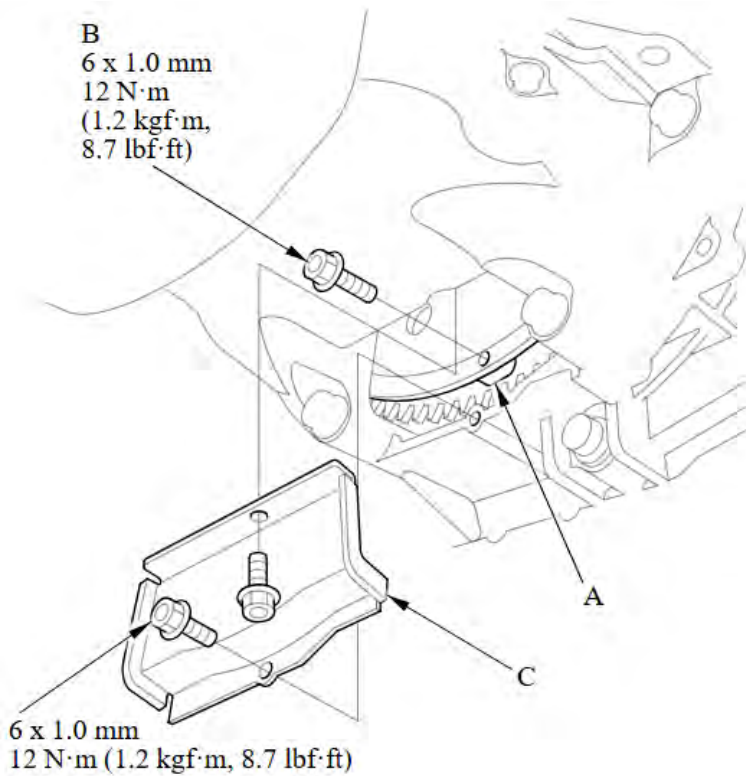

- 29. Position the lift table to support the engine and subframe.
- 30. Set a commercially available lift pad on the lift table to line up with the transmission.

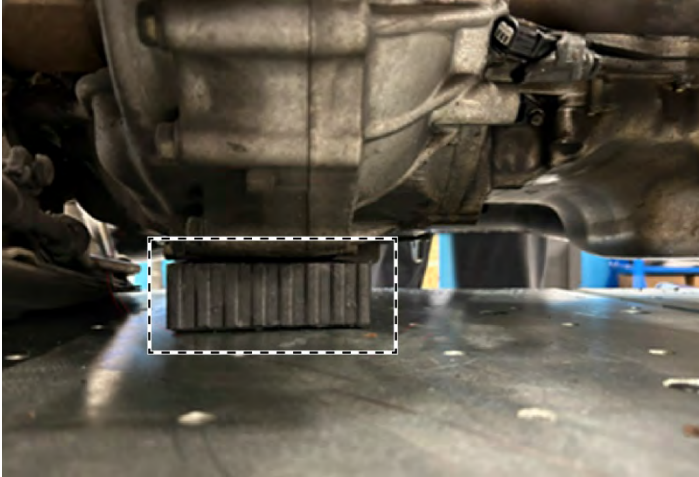

- 31. With the subframe supported by the lift table, remove the front and rear subframe bracket bolts, then remove the main subframe bolts.

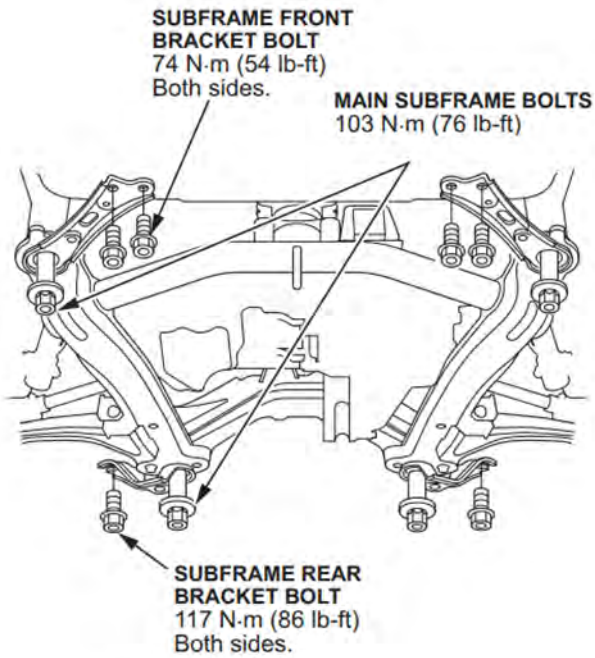

32. Lower the lift table.



33. With the lift table out of the way, lower the vehicle.

34. Remove the cylinder head dowel pins from the original engine block.

35. Remove the driveshaft heat cover.

36. Remove the rocker arm oil pressure sensor cover.

6 x 1.0 mm  
12 N·m  
(1.2 kgf·m,  
8.9 lbf·ft)

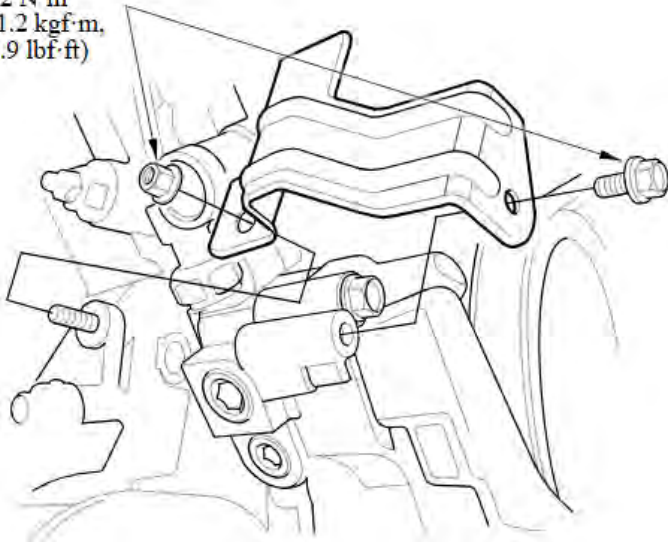

37. Remove the front engine mount stop (B).

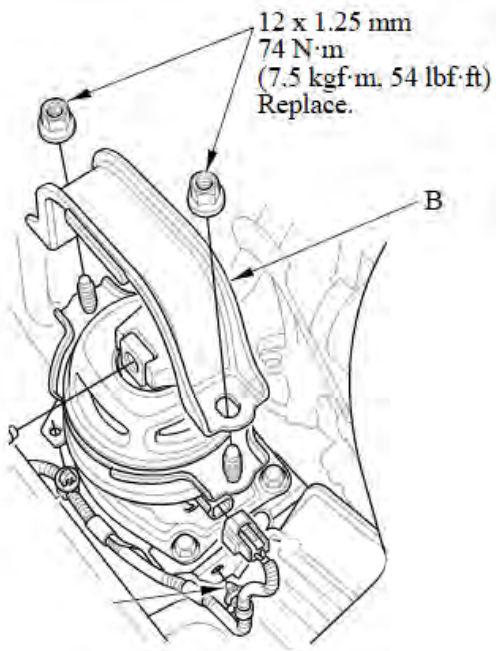

38. Remove the rear engine mount stop (C).

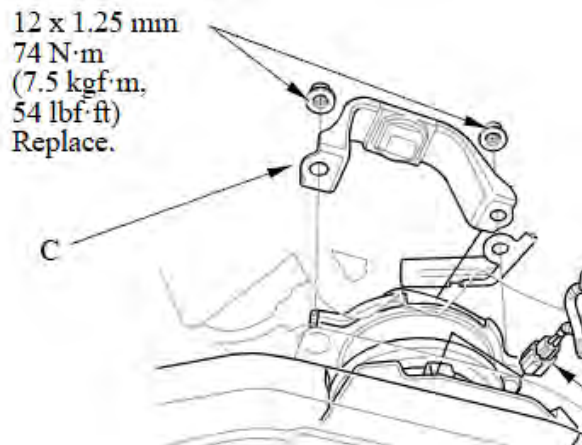

39. Remove the right driveshaft.

NOTE: It is not necessary to disconnect the right ball joint.

1. Remove the driveshaft bearing bracket bolts (A).

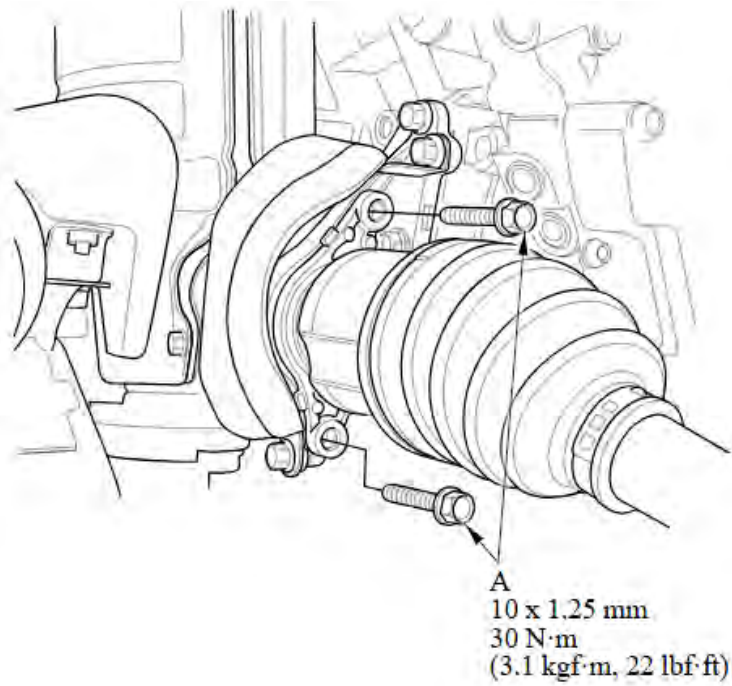

2. Remove the inboard joint (A) from the differential.

NOTE:

- Do not pull on the driveshaft (B), or the inboard joint may come apart.
- Pull the inboard joint straight out to avoid damaging the oil seal (C).
- Be careful not to damage the inboard joint ring (D).

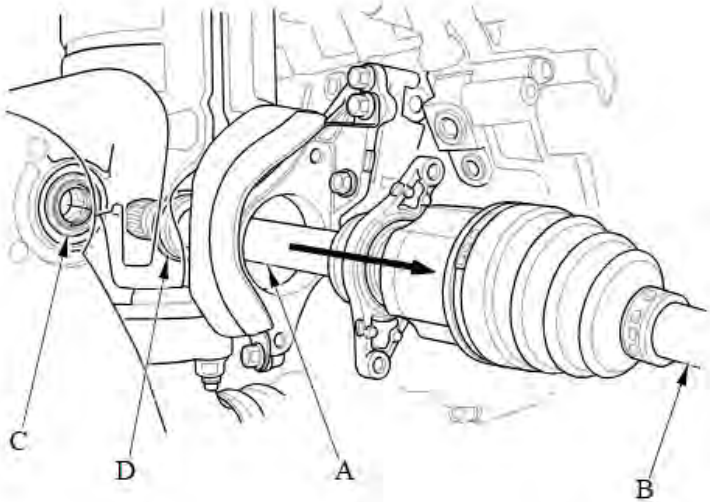

3. Remove the flange bolt (A) and the two dowel bolts (B), then remove the driveshaft support base (C).

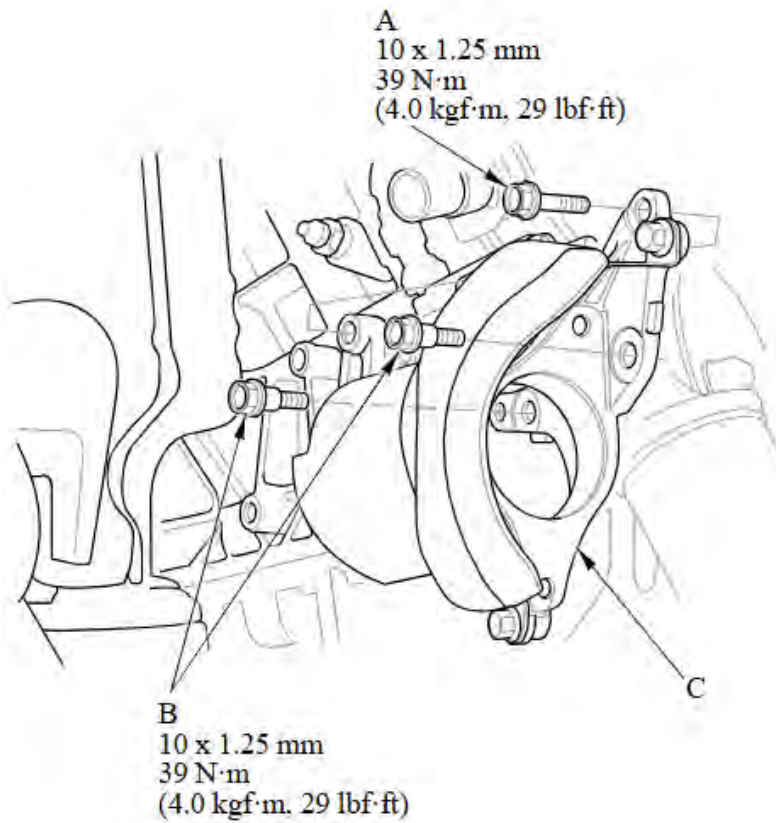

40. Remove the front and rear engine mount brackets from the front and rear engine mounts.
41. Loosen the front and rear engine mounting brackets from the engine block.
42. Loosen the top bolts connecting the transmission to the engine.
43. Attach the engine hoist and engine load leveler to engine block.



44. Remove the upper transmission hardware.

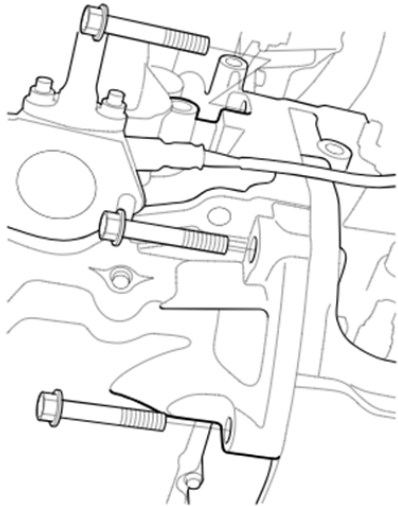

45. Remove the front engine mount.

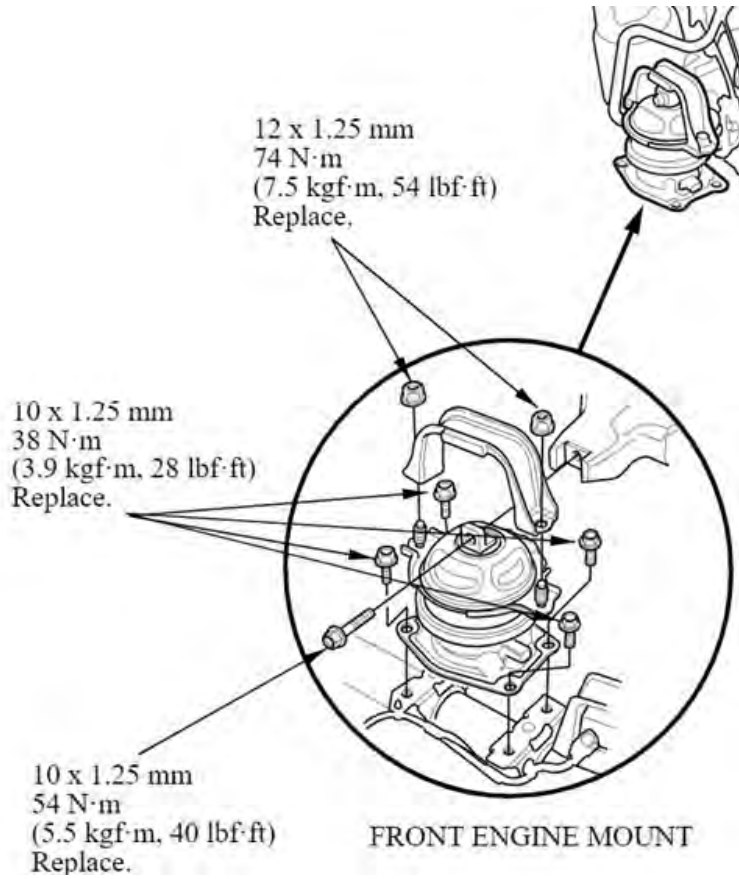

46. Remove the rear engine mount.

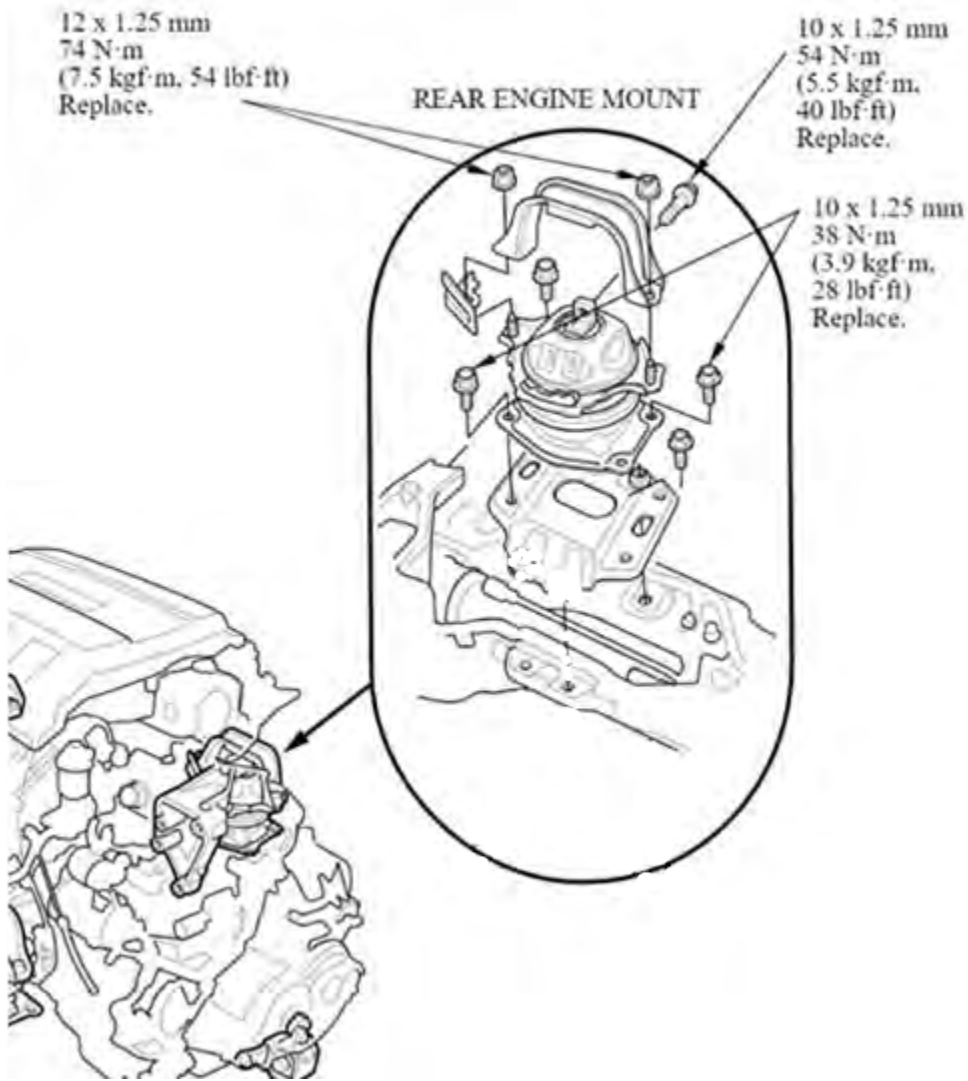

47. Remove the front engine mount bracket.
48. Separate the engine from the transmission.
49. Remove the engine short block and set the engine on a flat surface.
50. Remove the new engine short block from the box and set on a clean flat surface for preparation for parts to be transferred from the original engine short block.
51. Transfer the following parts from the original engine block to the new engine block:
  1. Remove and transfer the knock sensor harness (A) and knock sensor (B).

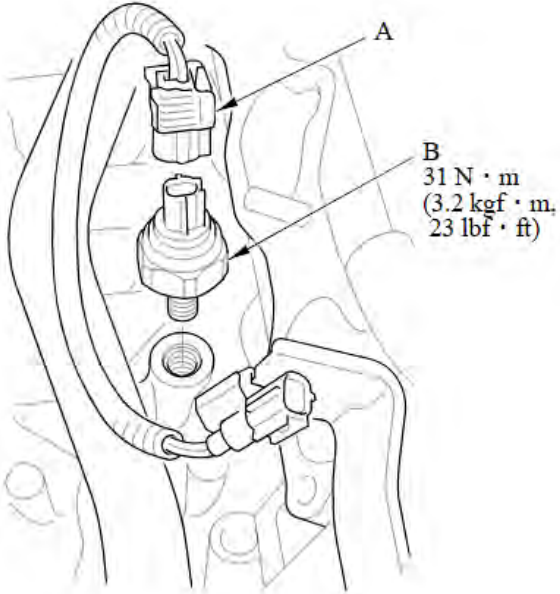

2. Remove the A/C compressor bracket from the old engine block and transfer to the new engine block.

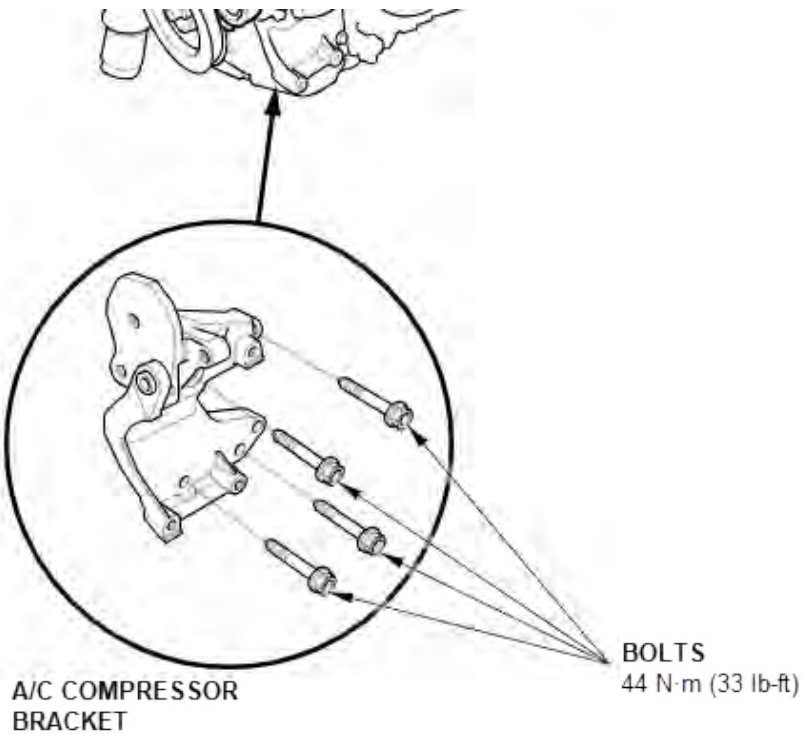

3. Remove and transfer the timing belt idler pulley.

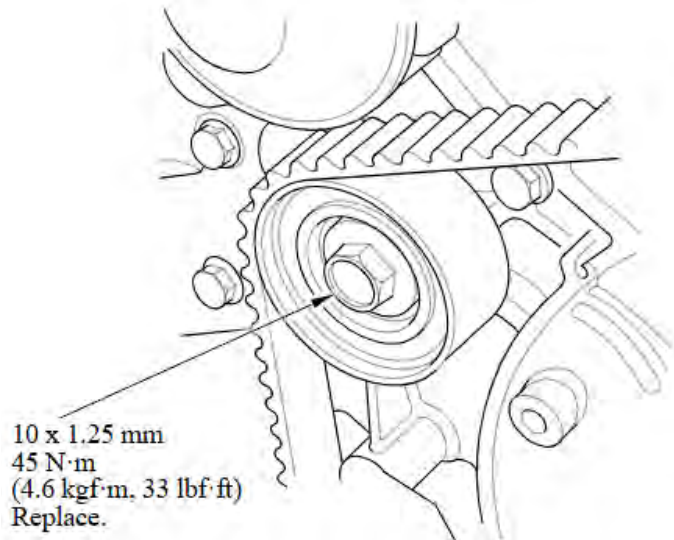

4. Remove the drive plate (A) and the washer (B) and transfer to the new engine.

NOTE: Install the drive plate and washer with the eight bolts, then tighten in a crisscross pattern in at least **two** steps.

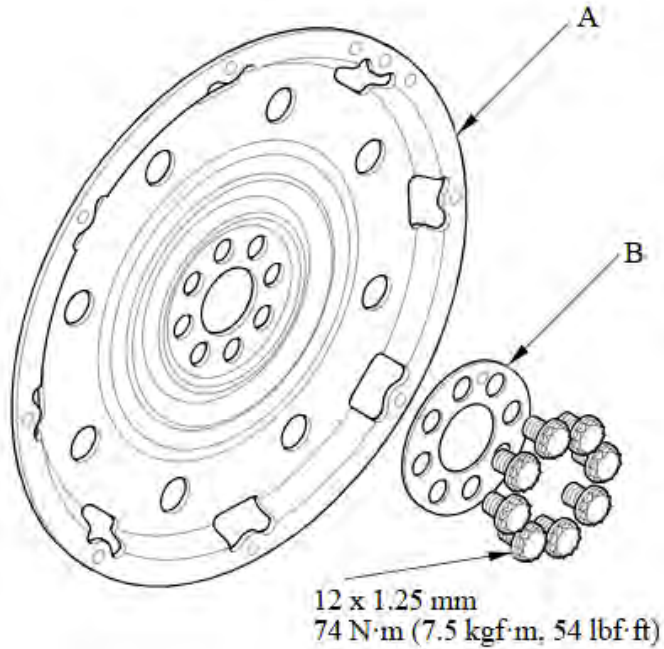

5. Remove and transfer the transmission dowel pins.



6. Remove and transfer rear engine mount bracket.

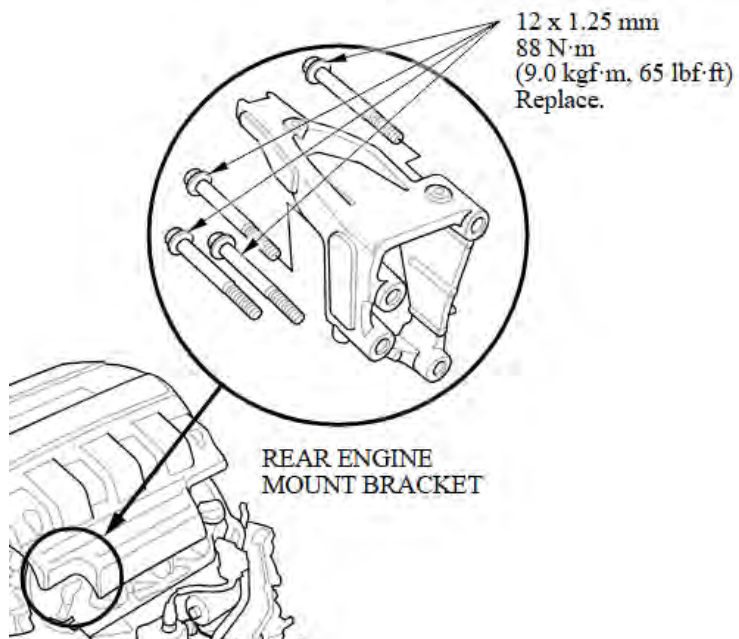

7. Remove and transfer the timing belt stopper (A), timing belt drive pulley (B), and the key (C).

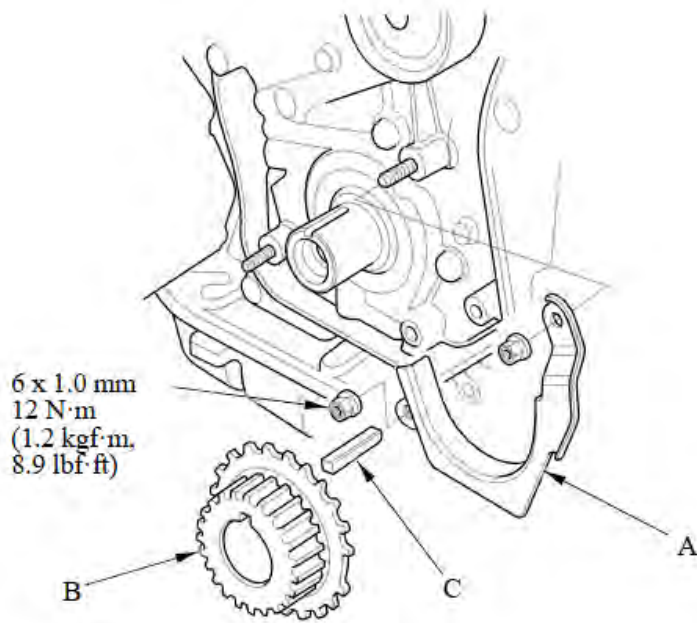

8. Remove and transfer the timing belt adjuster. Remove the bolt (A), then remove the timing belt adjuster (B) and the collar (C) and transfer to the new block.

NOTE: Install the timing belt adjuster in the reverse order of removal.

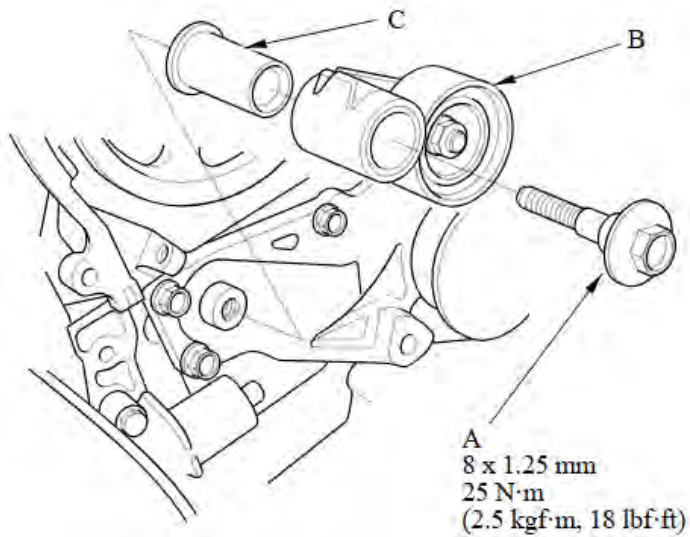

9. Remove the CKP sensor (C), then transfer to the new block with a new O-ring (D).

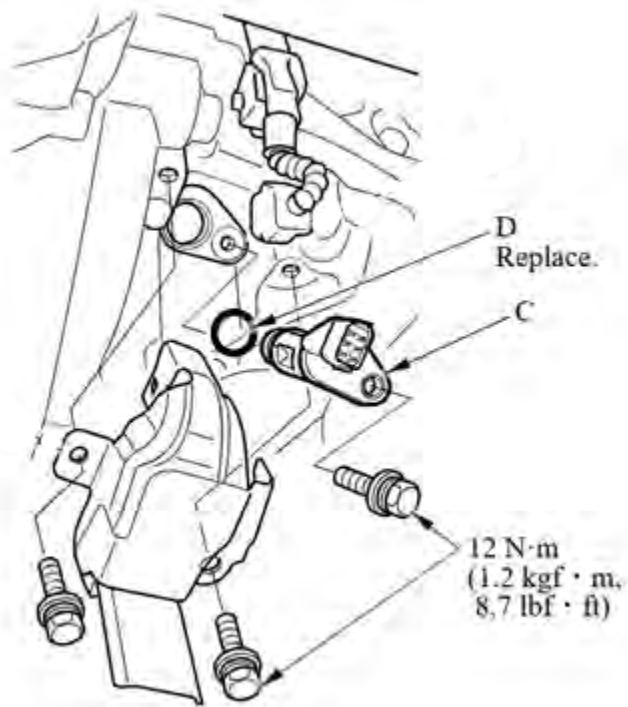

### Engine Installation

1. With the engine hoist and load leveler, lift the new engine block and line up to the transmission.
2. Install and torque the upper transmission hardware.

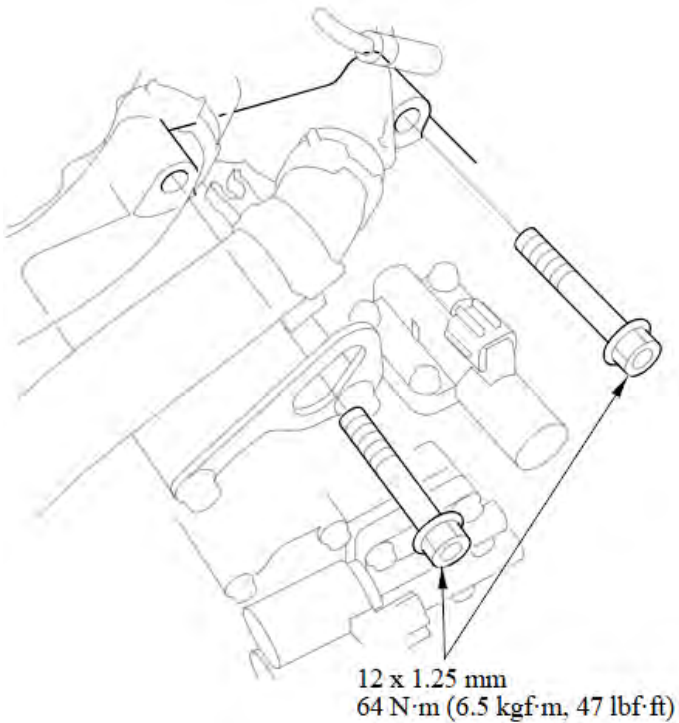

3. Install the front engine mount bracket.

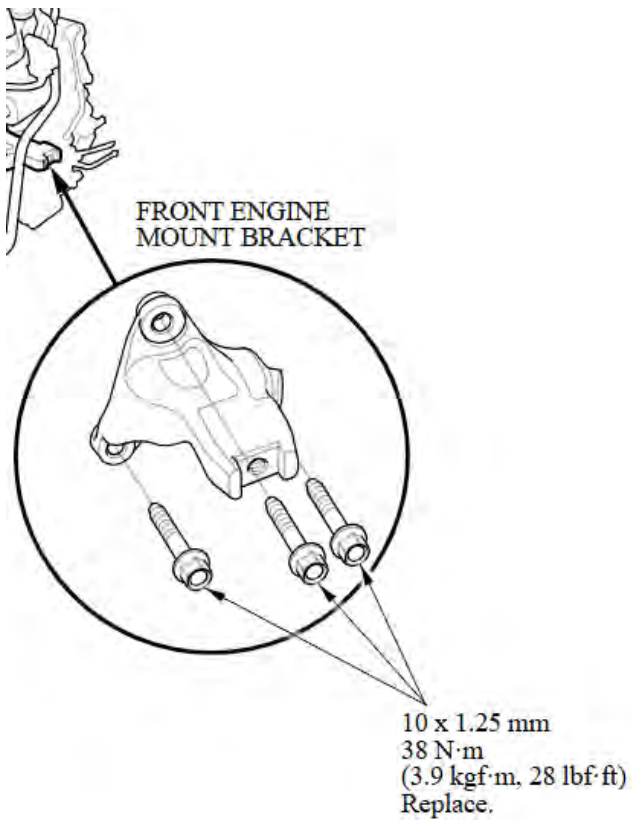

4. Loosely install the front engine mount using new bolts.

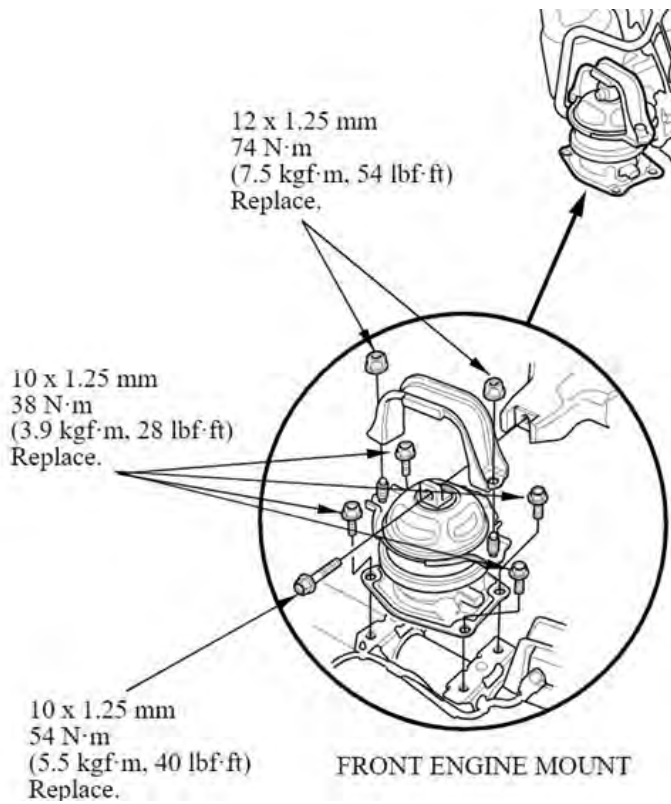

- Loosely install the rear engine mount with new nuts and bolts.

NOTE: **Do not** install the heatshield and the engine mount stop until the rear catalytic converter is installed.

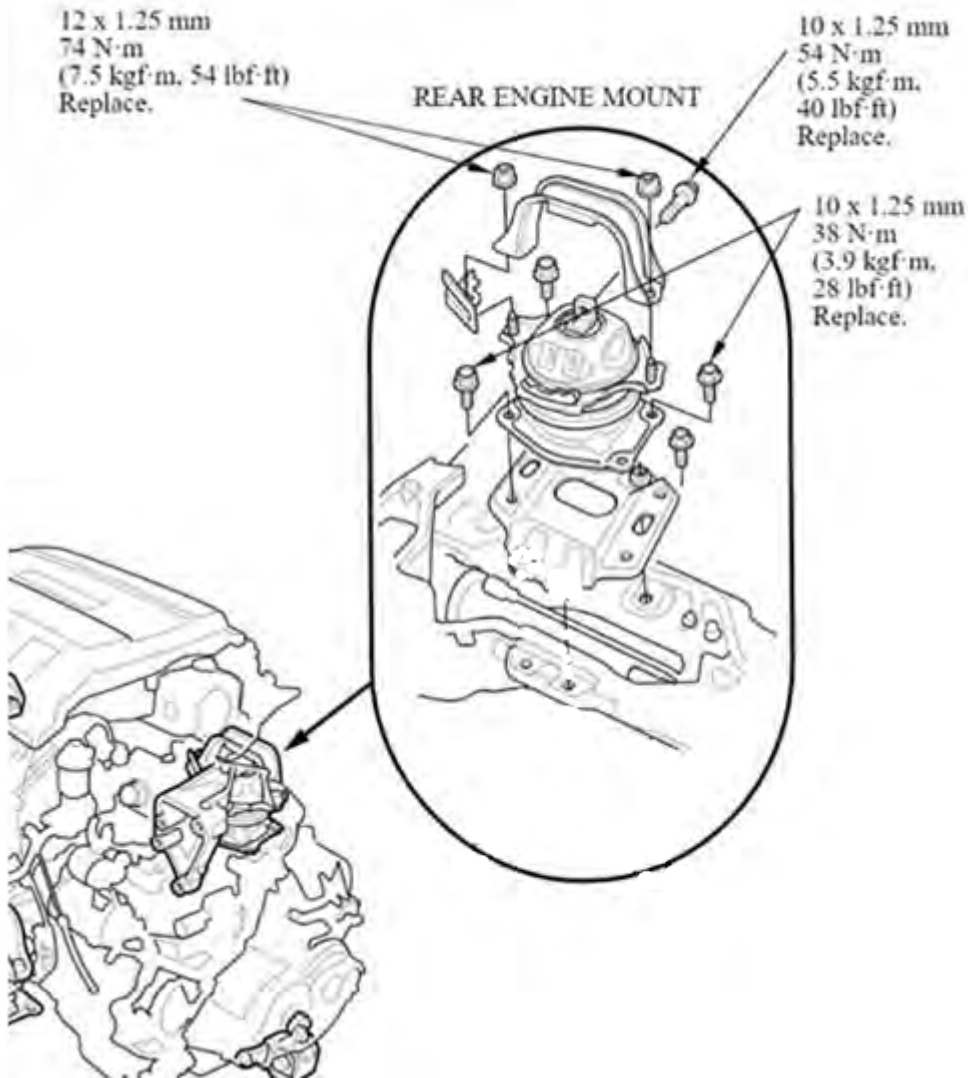

- Torque the front and rear engine mount bolts to specification.
- Remove the engine hoist.

8. Install the driveshaft base (C) and torque mounting bolts (A & B) to specification.

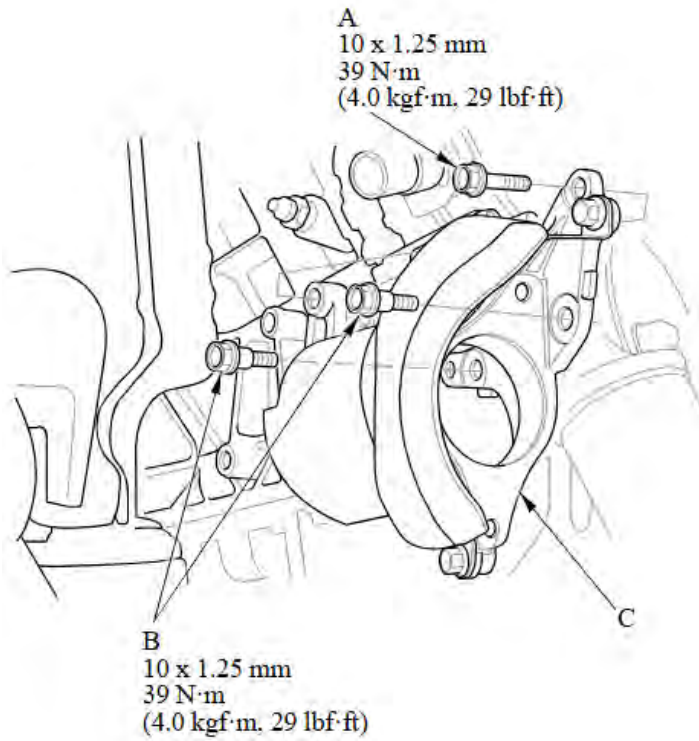

9. Install the right driveshaft.

NOTE: Before starting installation, make sure the mating surfaces of the joint and the splined section are clean.

1. Apply about 5 g (0.18 oz) of moly 60 paste to the contact area (A) of the outboard joint and the front wheel bearing.

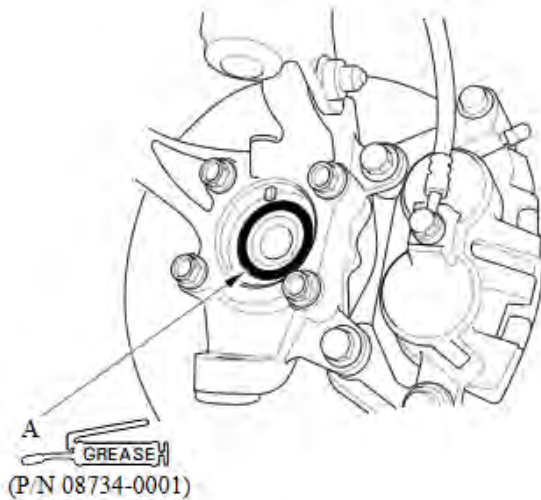

2. Clean the areas where the driveshaft contacts the differential thoroughly with solvent, then dry them with compressed air.

NOTE: **Do not** wash the rubber parts with solvent.

3. Insert the inboard joint (A) into the differential.

NOTE:

- Insert the driveshaft horizontally to prevent damaging the oil seal (B).
- Be careful not to damage the inboard joint ring (C).
- Make sure to set the “TOP” mark of the driveshaft bearing bracket (D) to the upper side when installing it.

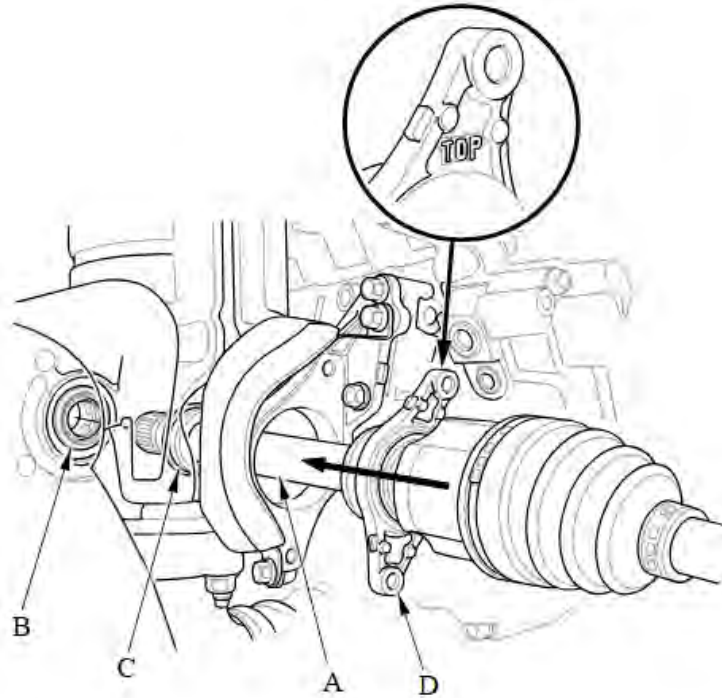

4. Install the driveshaft bearing bolts.

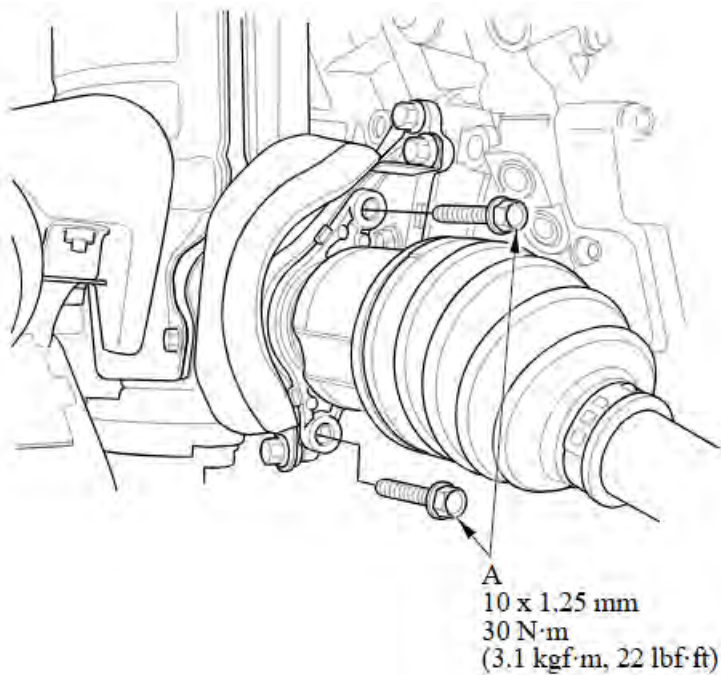

5. Install the driveshaft heat cover.

10. Install the rocker arm oil pressure sensor cover.

6 x 1.0 mm  
12 N·m  
(1.2 kgf·m,  
8.9 lbf·ft)

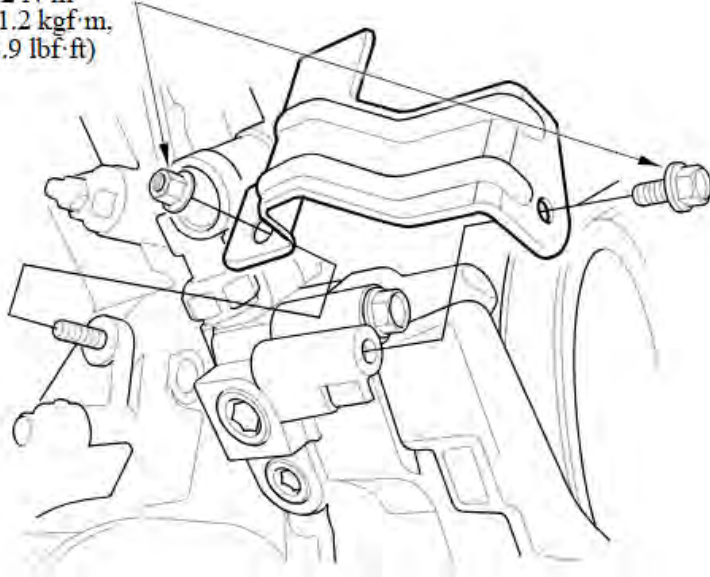

11. Install the coolant connecting pipe with new O-rings onto the engine block.



CONNECTING PIPE

12. Transfer the original cylinder head dowel pins (C), then install new head gaskets (D).

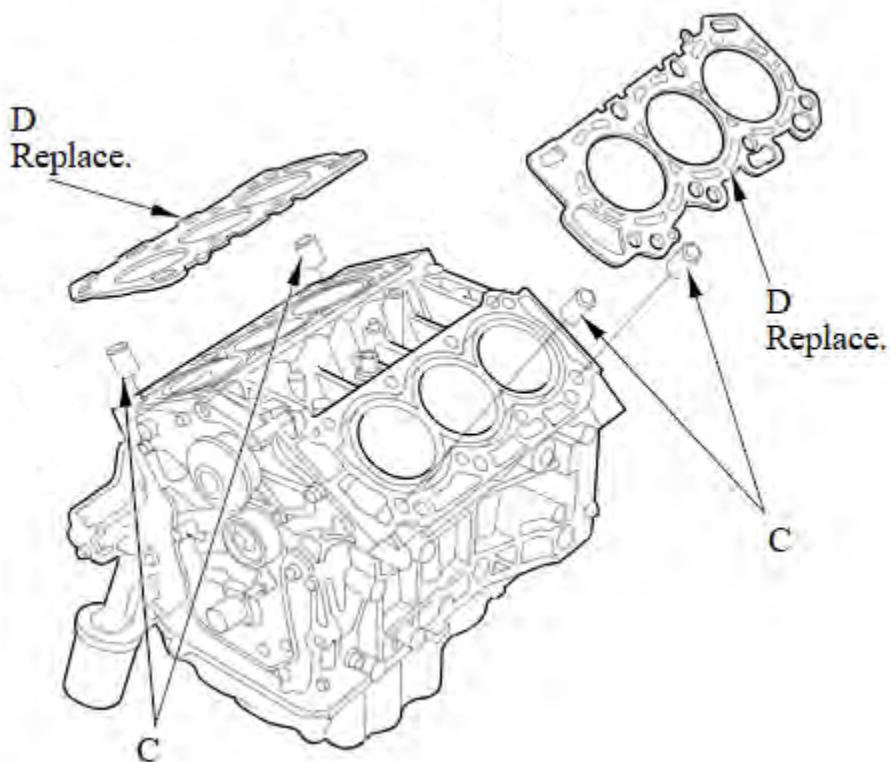

13. Install the cylinder heads:

1. Clean the timing belt pulleys, the timing belt guide plate, and the upper and lower covers.
2. Set the timing belt drive pulley to top dead center (TDC) by aligning the TDC mark (A) on the timing belt drive pulley with the pointer (B) on the oil pump.

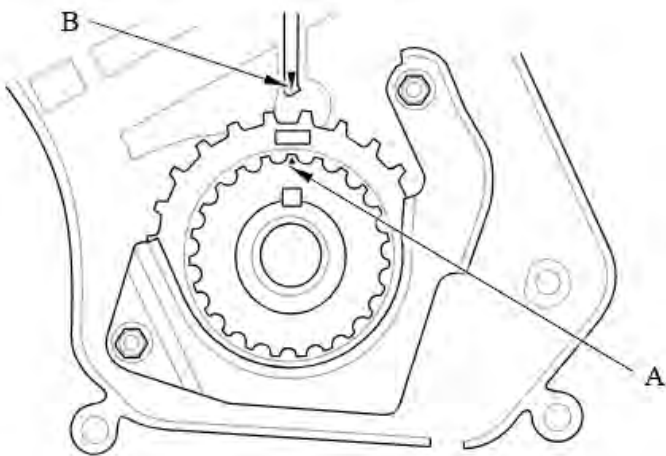

3. Set the camshaft pulleys to TDC by aligning the TDC marks (A) on the camshaft pulleys with the pointers (B) on the back covers.

FRONT

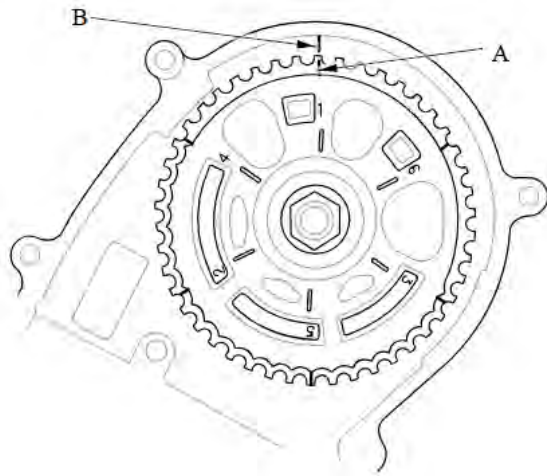

REAR

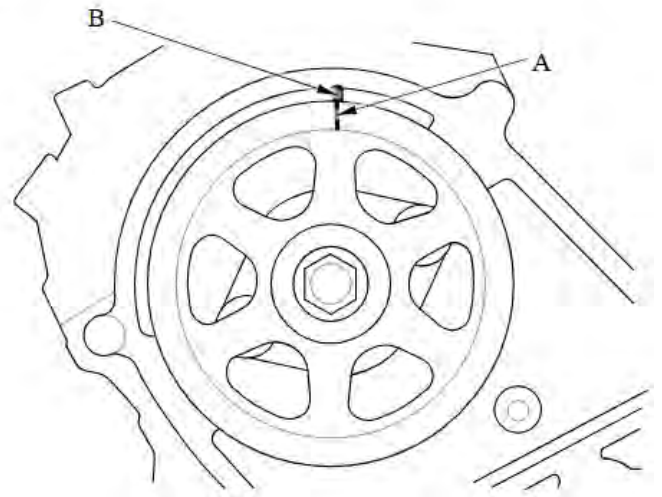

4. Install the cylinder heads onto the engine block.

NOTE: Cylinder head bolt diameter measurement was checked during disassembly. Replace any bolts that are outside specification.

5. Apply new engine oil to the threads and under the bolt heads of all cylinder head bolts.

6. Torque the cylinder head bolts in sequence to **29 N·m (22 lb-ft)** using a beam-type torque wrench.

**NOTE:**

- When using a preset click-type torque wrench, be sure to tighten slowly and do not overtighten.
- If a bolt makes any noise while it is being torqued, loosen the bolt and retighten it from the first step.

**Front**

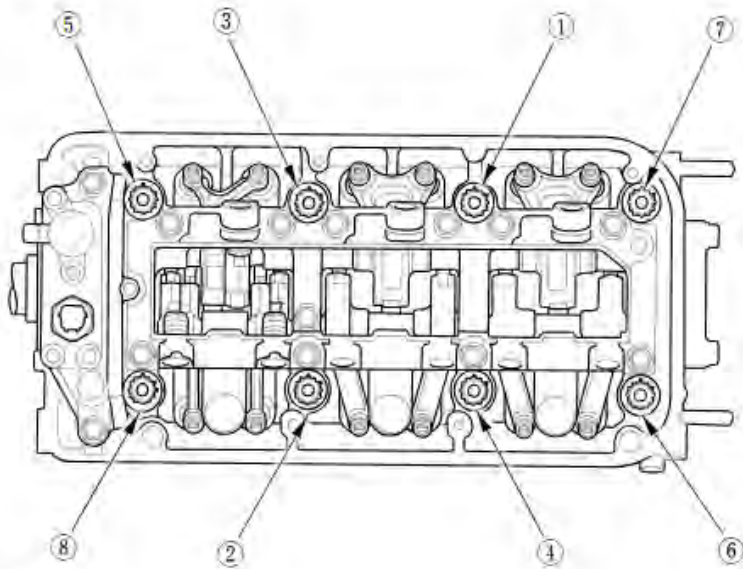

**Rear**

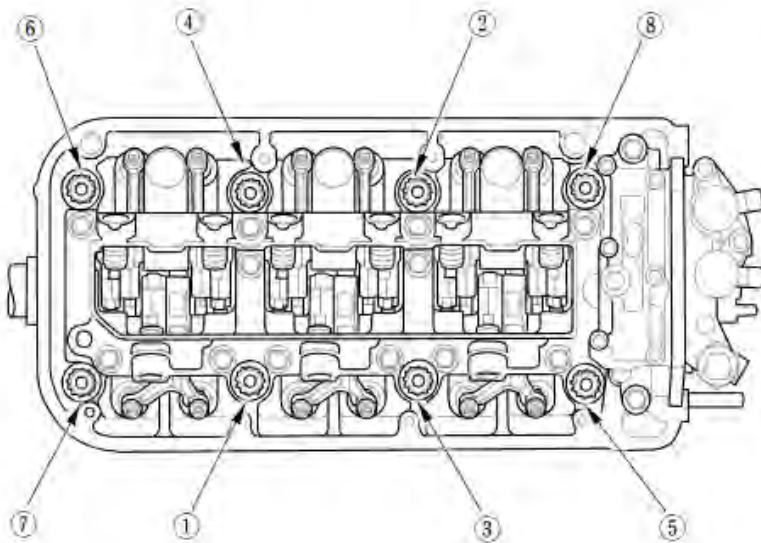

- After all bolts have been torqued to **29 N·m (22 lb·ft)**, tighten all cylinder head bolts in two steps (**90° per step**) using the same sequence as above.

NOTE:

- If you are installing a new cylinder head bolt, tighten the bolt an extra **90°**.
- If you tightened a bolt beyond the specified angle, remove the bolt and start again at step 6 of the procedure. **Do not** loosen it back to the specified angle.

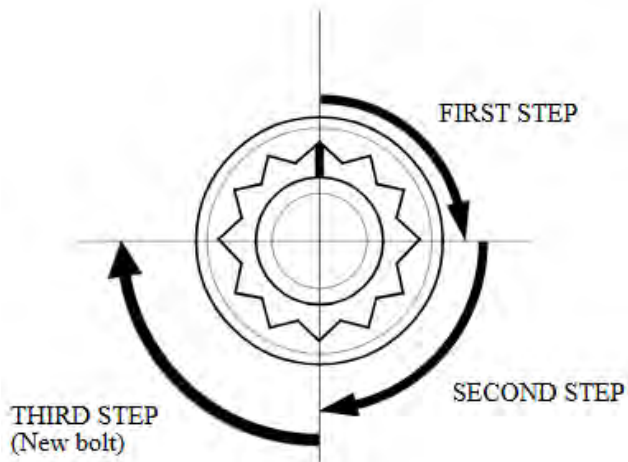

- Install the timing belt:

1. Install the timing belt auto-tensioner.

NOTE: Refer to the service manual for the procedure to compress the tensioner before installation.

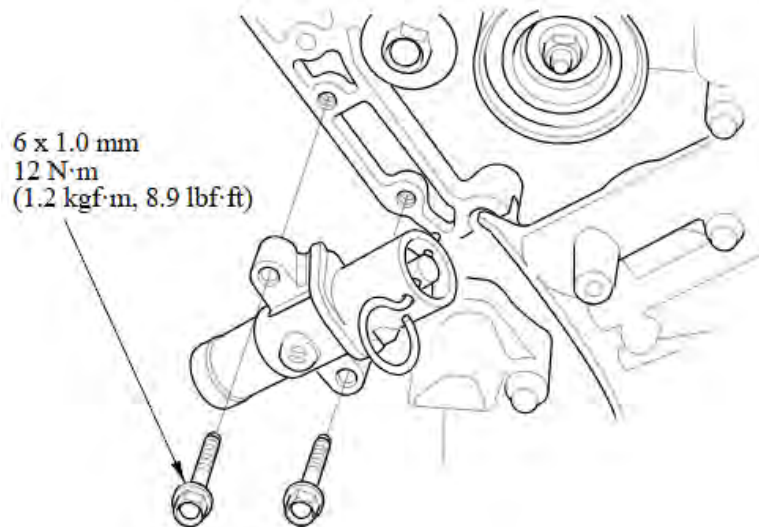

2. Install the timing belt in a counterclockwise sequence starting with the drive pulley, being careful not to damage the timing belt during installation.

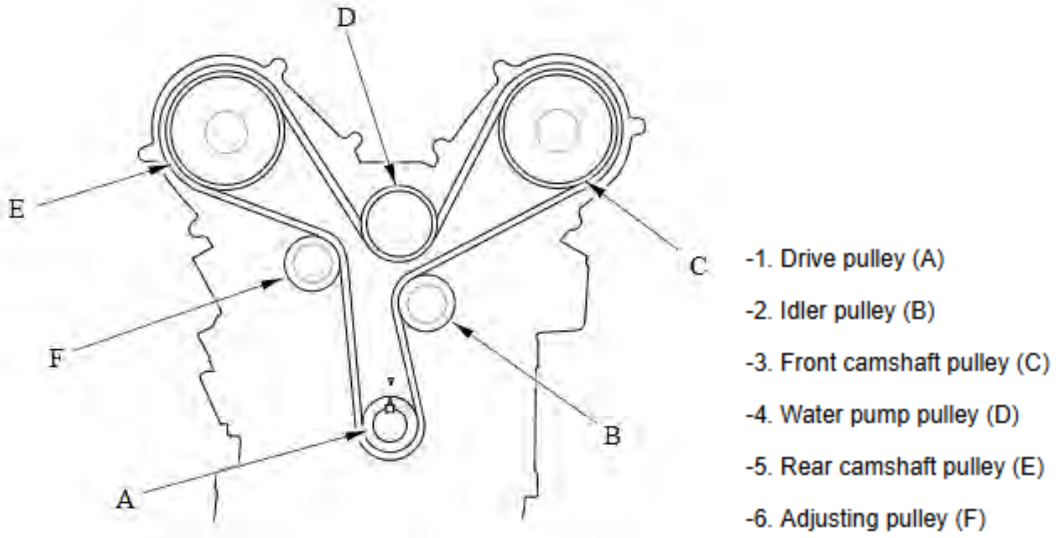

3. Tighten the idler pulley bolt.

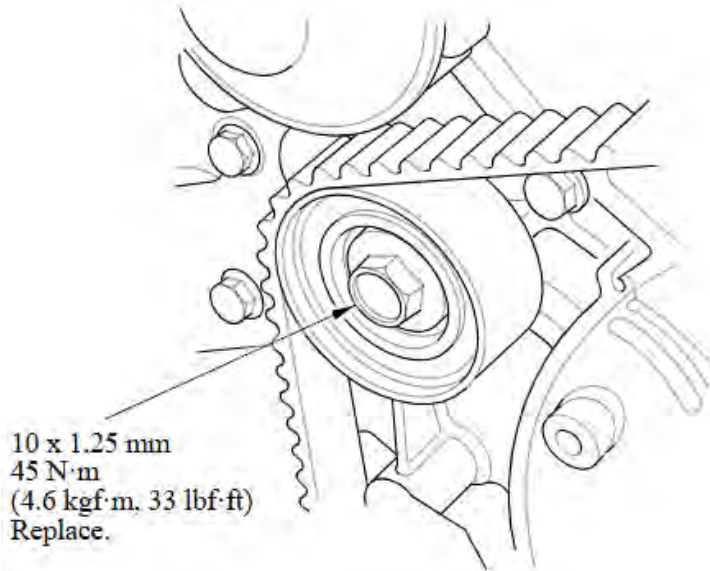

4. Remove the pin from the auto-tensioner.

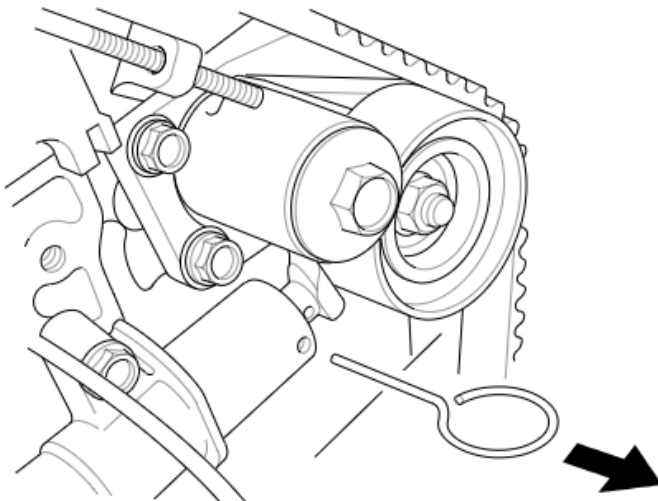

5. Install the lower half of the side engine mount bracket using new bolts where required.

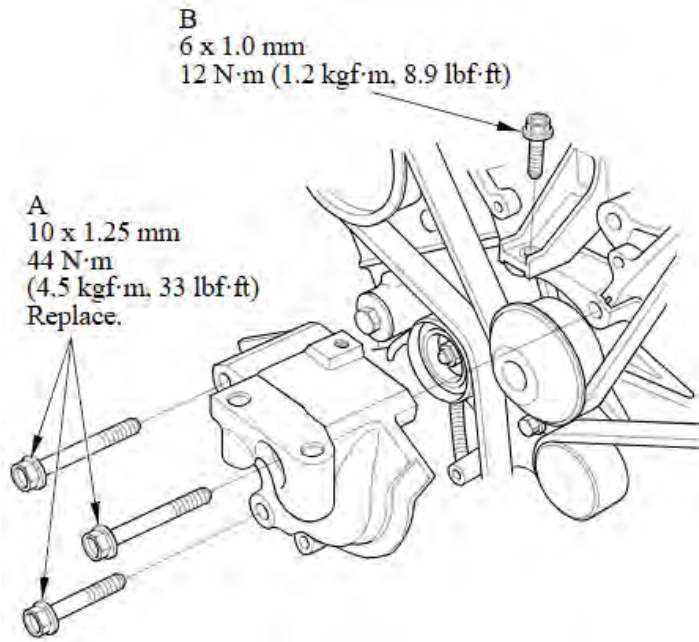

7. Install the timing belt guide plate (A).

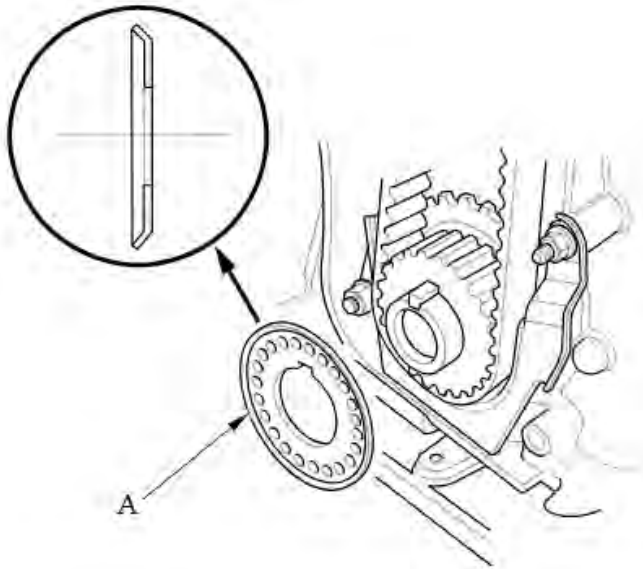

8. Install the lower timing belt cover.

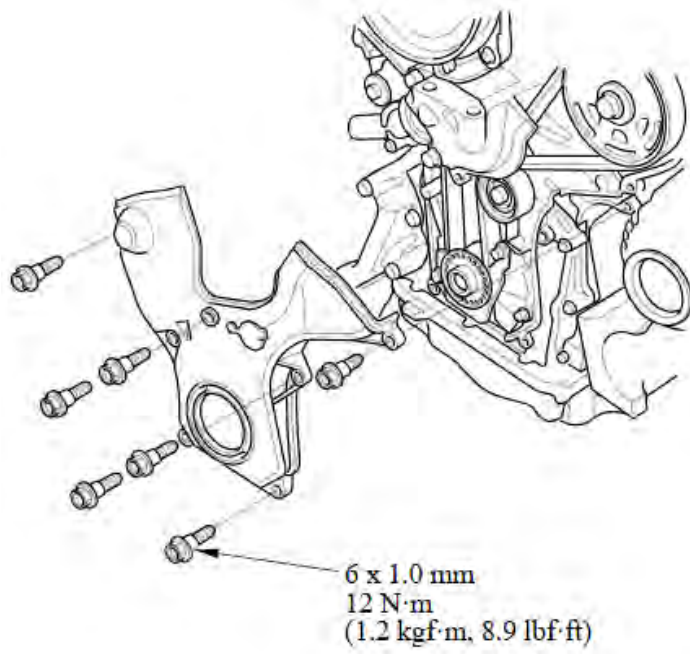

9. Install the upper timing belt covers (A & B).

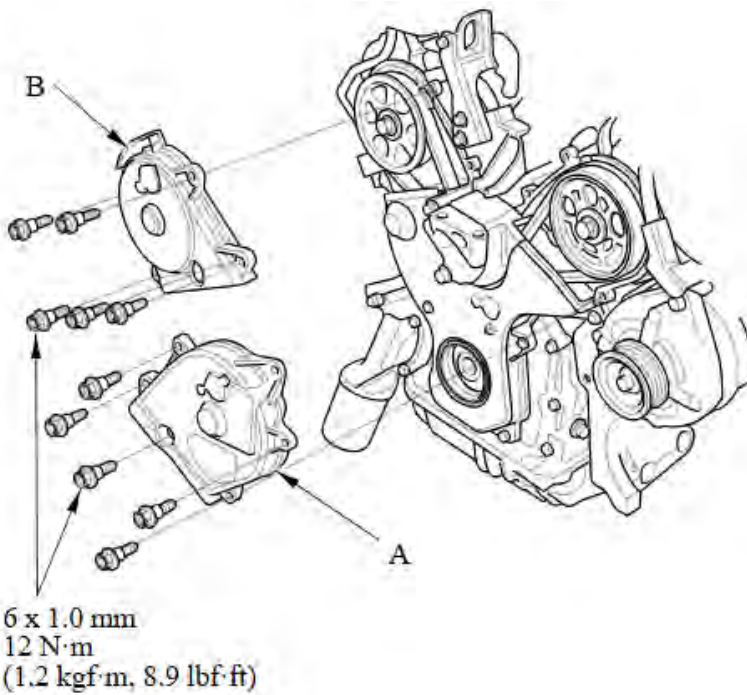

10. Install the crankshaft pulley:

1. Remove any oil and clean the pulleys (A), the crankshaft (B), the bolt (C), and the washer (D). Lubricate with new engine oil.

- ✕ : Remove any oil
- : Clean
- : Lubricate with new engine oil

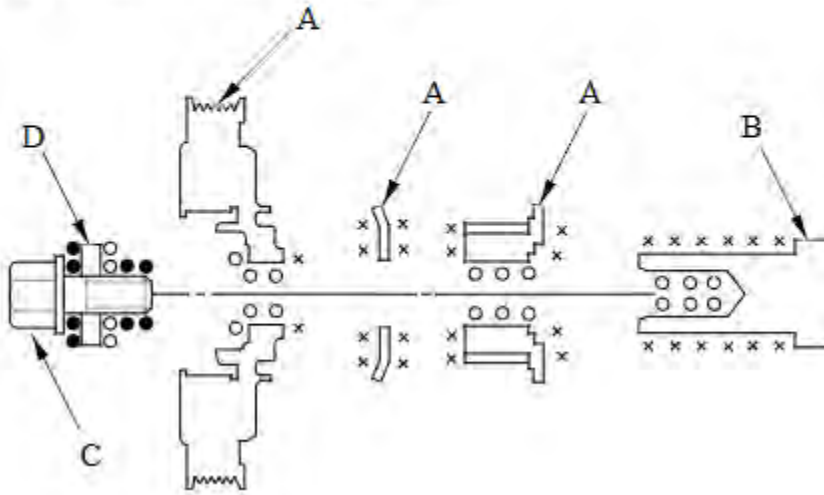

2. Install the crankshaft pulley and tighten the bolt.

NOTE: **Do not** use an impact wrench.

1. Hold the pulley with the handle (A) and the holder attachment (B). Torque the bolt to **65 N·m (48 lb-ft)**.

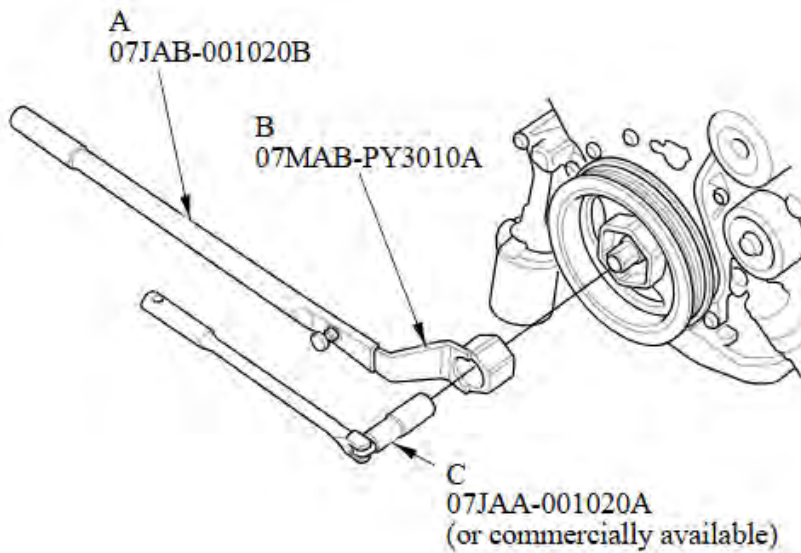

2. Tighten the bolt an additional 60°.

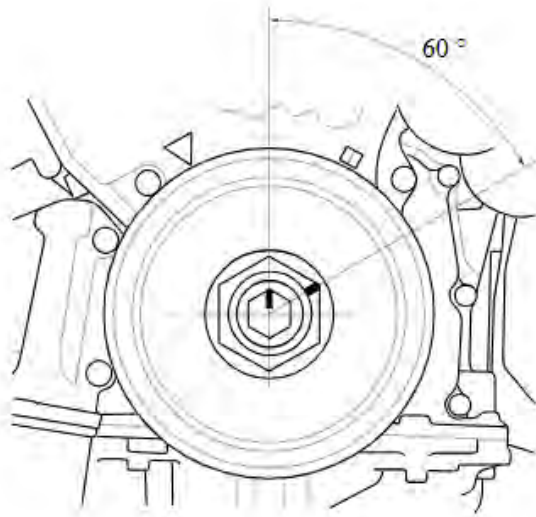

11. Rotate the crankshaft pulley six full turns clockwise to allow the timing belt to position itself on the pulleys.
  12. Turn the crankshaft pulley so the white mark (A) lines up with the pointer (B).
- NOTE: The other pointer (C) is not used.

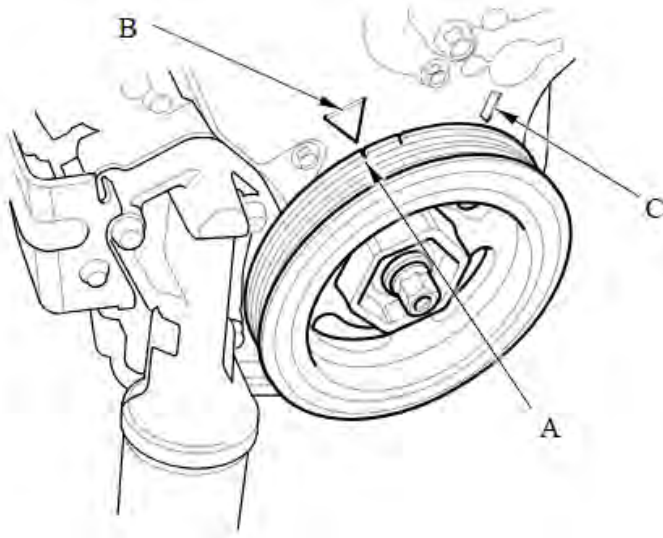

13. Check the camshaft pulley marks:

NOTE: If the marks are not aligned, rotate the crankshaft 360 degrees and recheck the camshaft pulley mark.

Are the camshaft marks at TDC?

**YES** – Proceed to the next step.

**NO** – Remove the timing belt and repeat the installation process.

FRONT

REAR

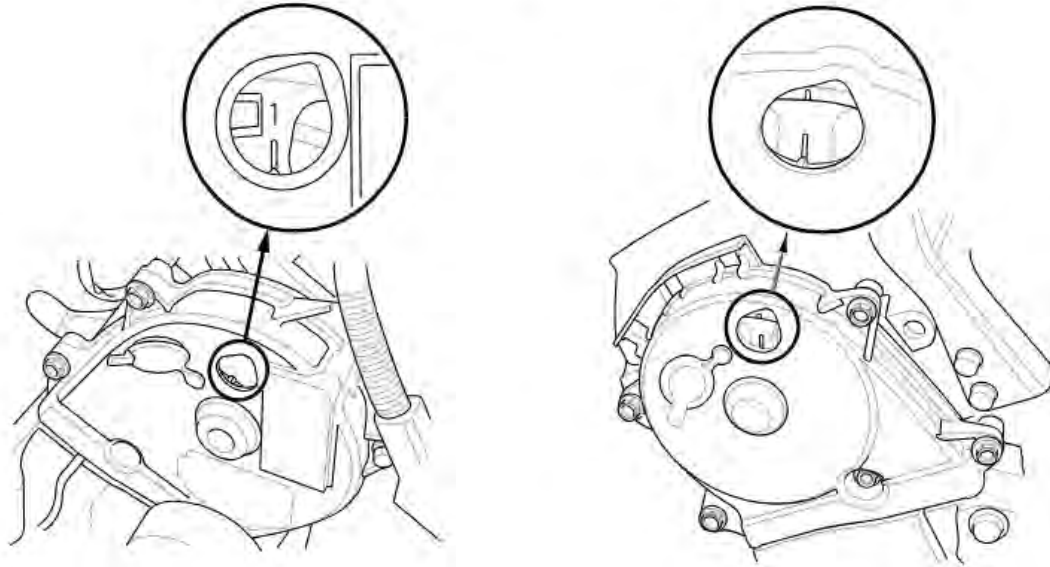

15. Adjust the valve clearance:

NOTE: Refer to the service manual for the full procedure.

**Valve Clearance**

<b>Intake</b>	0.20 - 0.24 mm (0.008 – 0.009 in)
<b>Exhaust</b>	0.28 - 0.32 mm (0.011 – 0.012 in)

REAR

FRONT

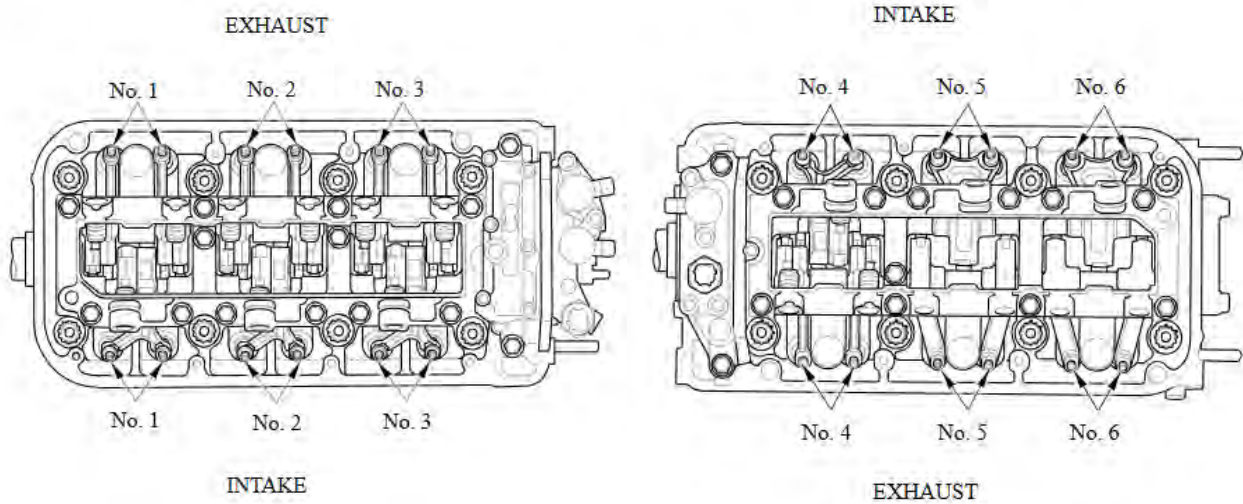

16. Apply Hondabond to the rocker arm oil control valve mating surface (A). Install the component within **5 minutes** of applying the Hondabond.

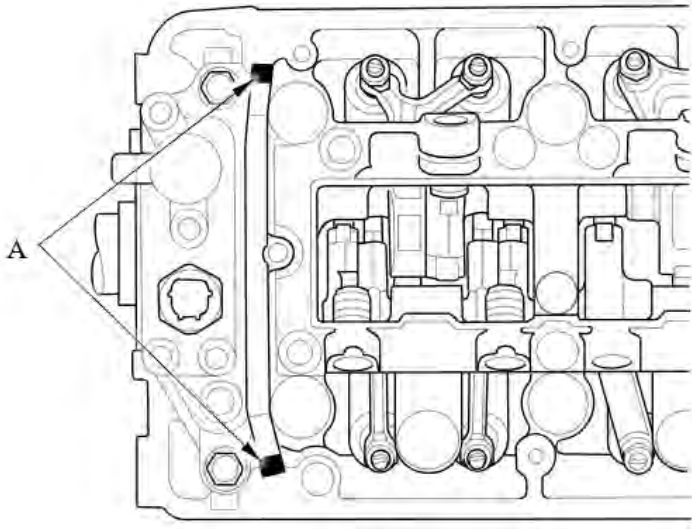

17. Set the spark plug seals (A) on the spark plug tubes and install the cylinder head covers (B).

NOTE: Tighten the bolts (C), in sequence, in three steps.

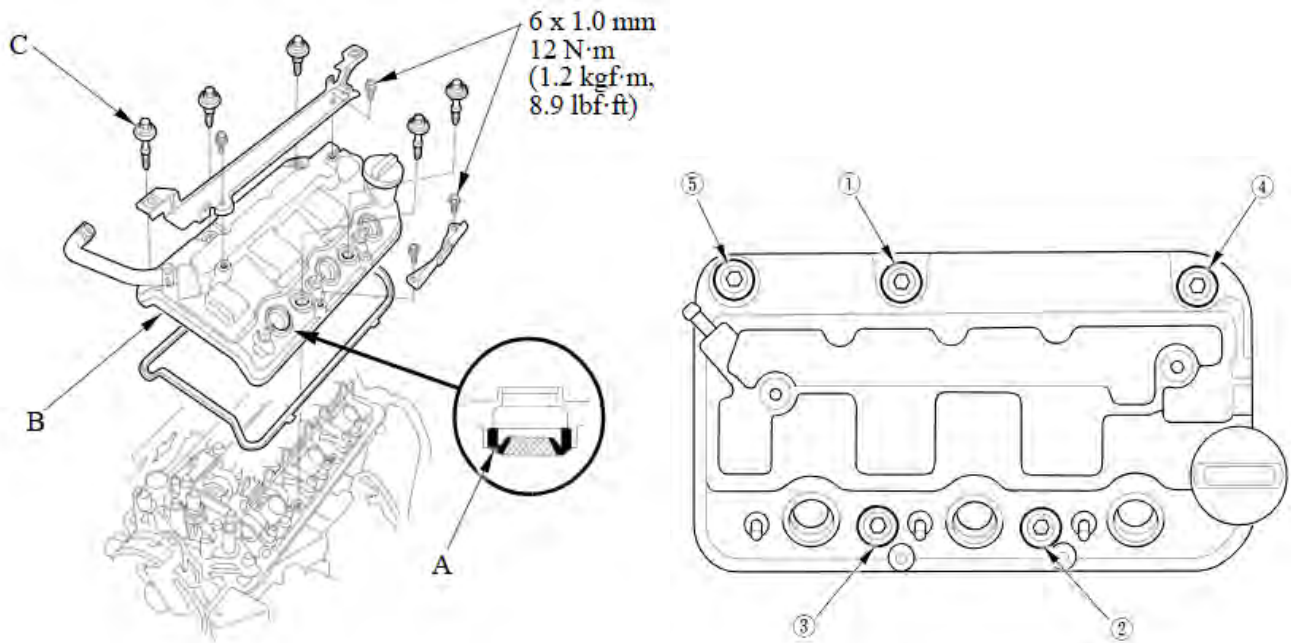

18. Install the water passage with new water passage gaskets to the connecting pipe that was installed earlier.

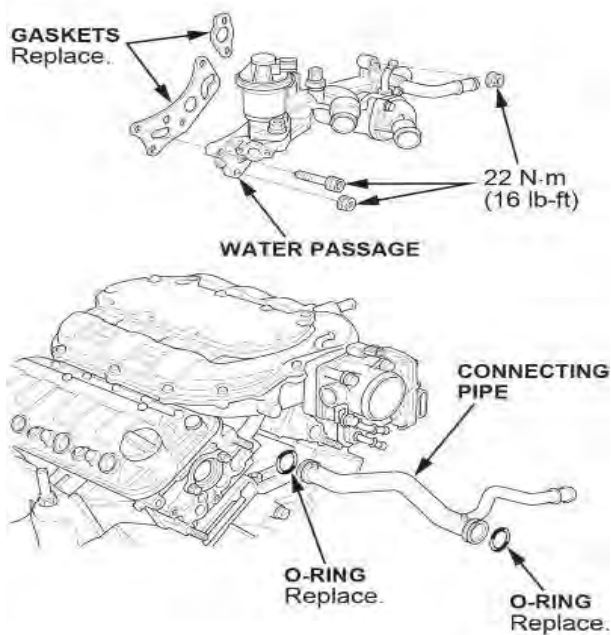

19. Install the fuel joint pipe to the fuel rails with new O-rings, then attach the quick connect fitting and torque the bracket mounting bolt to **22 N·m (16 lb-ft)**.

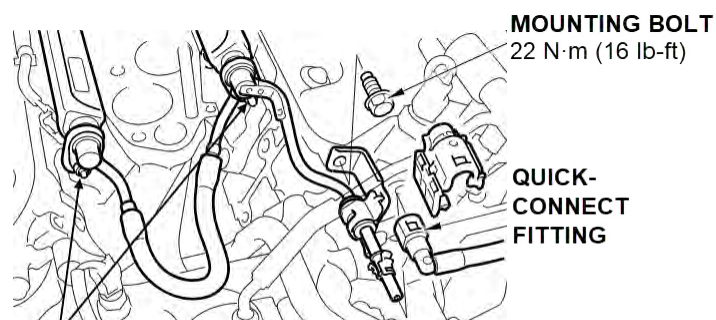

**NUTS**  
12 N·m (9 lb-ft)

20. Install the engine wire harness.

21. Install the breather pipe.

22. Install the connector bracket (A) to the front cylinder head.

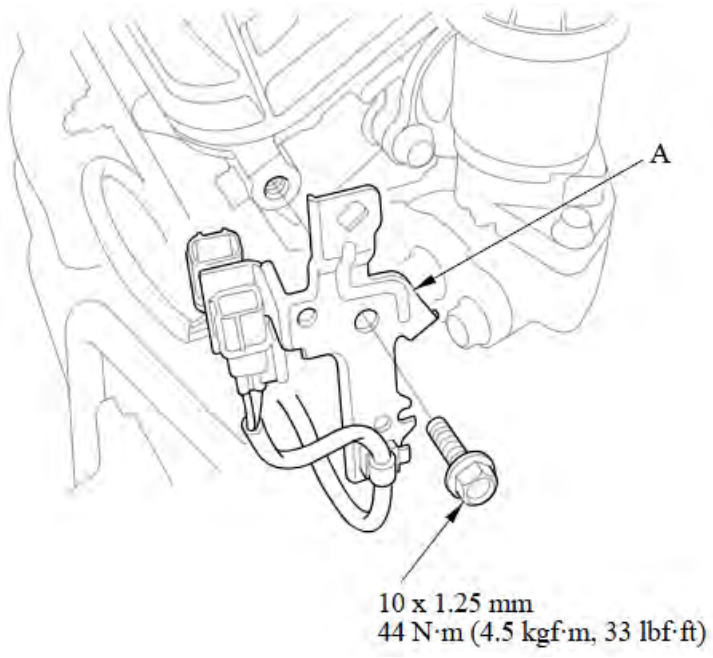

23. Install the harness bracket (A) to the rear cylinder head.

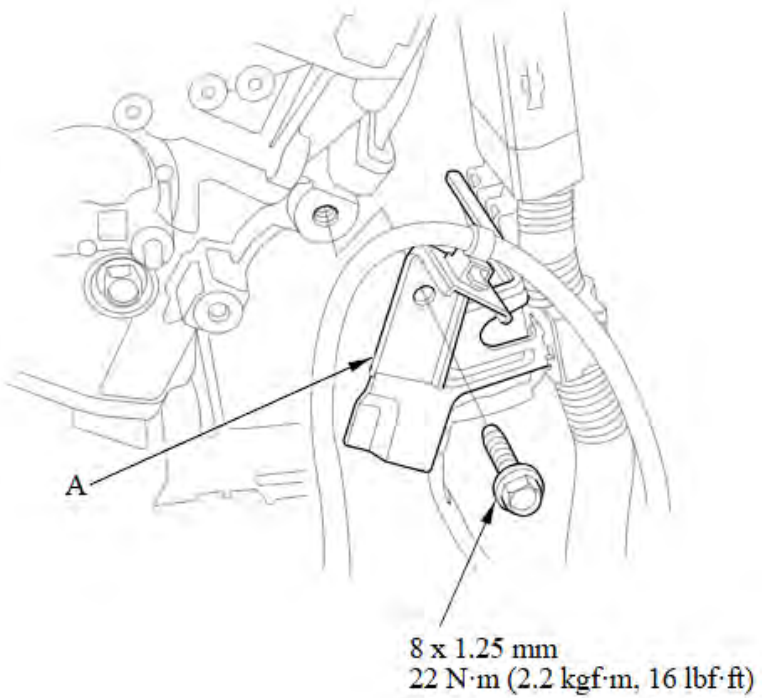

24. Install the intake manifold with a new intake manifold gasket.

NOTE: Tighten the bolts and nuts in three steps, following the torque sequence.

**Specified Torque**

**8 x 1.25 mm: 22 N·m (2.2 kgf·m, 16 lbf·ft)**

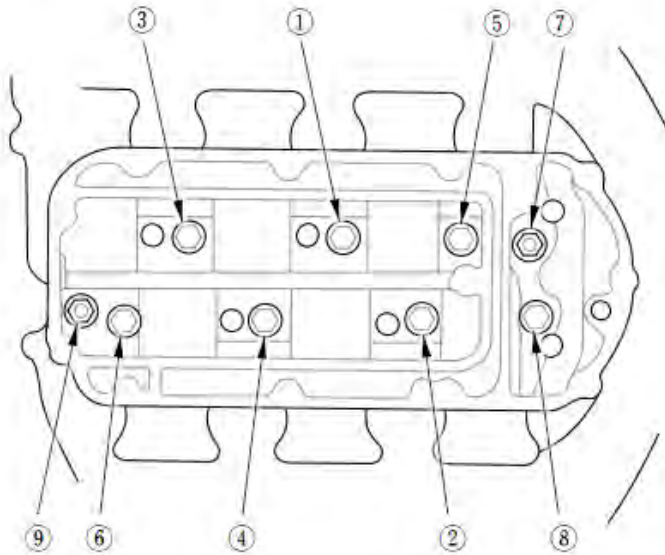

25. Install the upper cover (A) with a new upper cover gasket.

NOTE: Tighten the bolts and nuts in three steps, following the torque sequence.

**Specified Torque**

**6 x 1.0 mm: 12 N·m (1.2 kgf·m, 8.9 lbf·ft)**

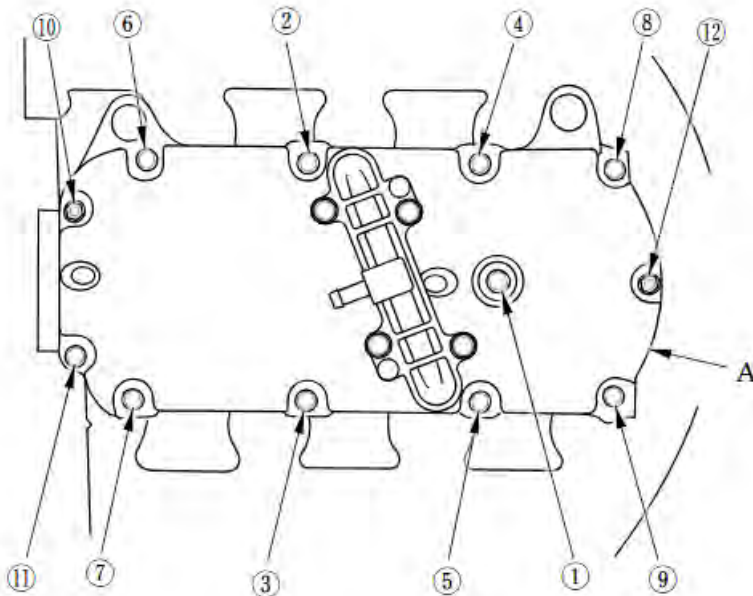

26. Install the front catalytic converter with a new gasket and new self-locking nuts. Tighten the nuts in a crisscross pattern in two to three steps. Final torque the mounting nuts to **31 N·m (23 lb-ft)**.

27. Install the rear catalytic converter with a new gasket and new self-locking nuts. Tighten the nuts in a crisscross pattern in two to three steps. Final torque the mounting nuts to **31 N·m (23 lb-ft)**.

28. Install the rear engine mount stop and heat shield with new nuts and torque to **74 N·m (54 lb-ft)**.

29. Install the starter assembly with a new gasket and torque the mounting bolts to **44 N·m (33 lb-ft)**.

NOTE: Refer to service manual for the full procedure.

30. Install the front engine mount stop with new nuts and torque to **74 N·m (54 lb-ft)**.

31. Install the EGR Pipe and torque the mounting bolts and nuts to **22 N·m (16 lb-ft)**.

32. Install the spark plugs (4 new) then install the ignition coils and connectors.

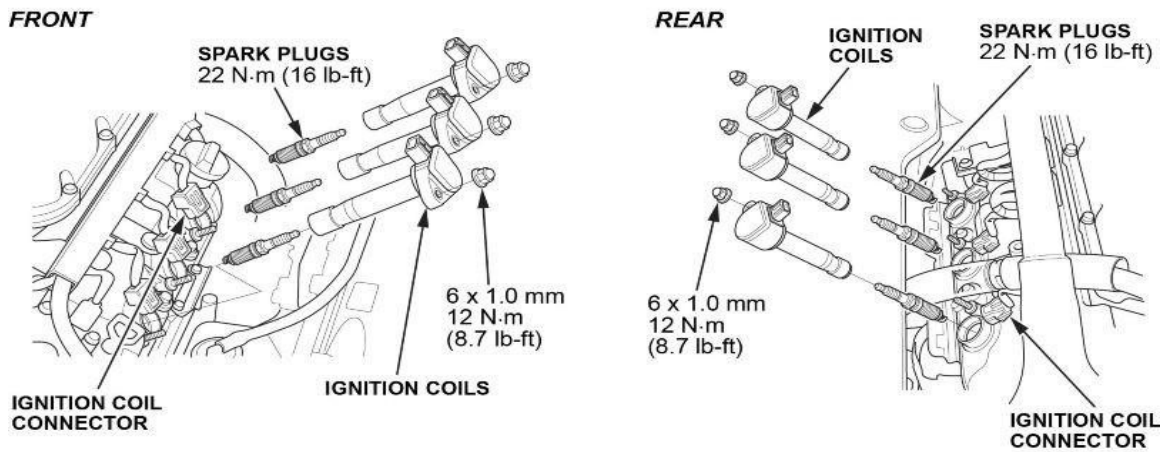

33. Raise the vehicle.

34. Line up lift table and engine assembly under the vehicle.

35. Raise the lift table while lining up the subframe with the mounting holes on the bottom of the vehicle.

NOTE: Use the subframe align pin if needed (**070AG-SJAA10S**).

36. Install the subframe with **new** bolts where indicated, then torque in sequence to specification.

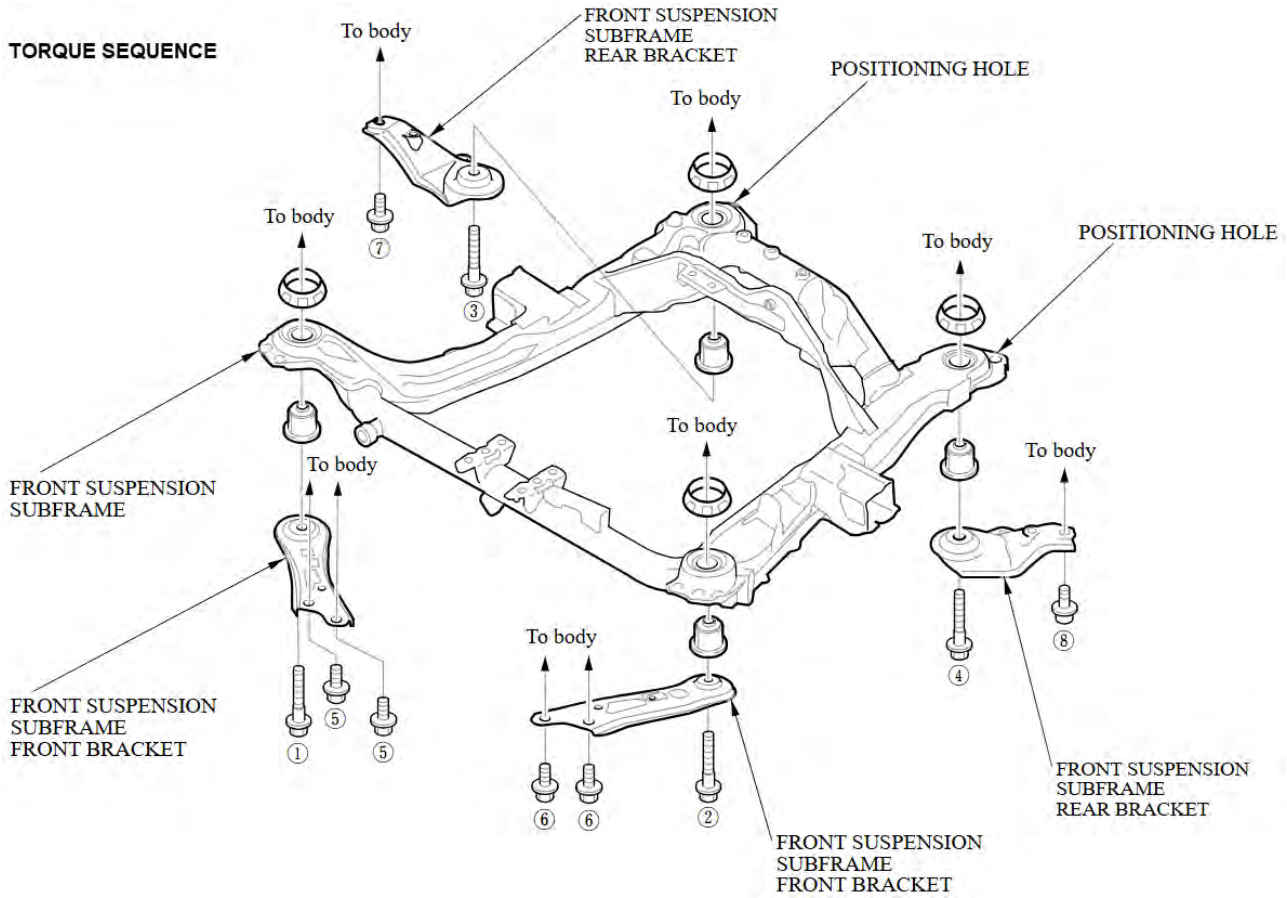
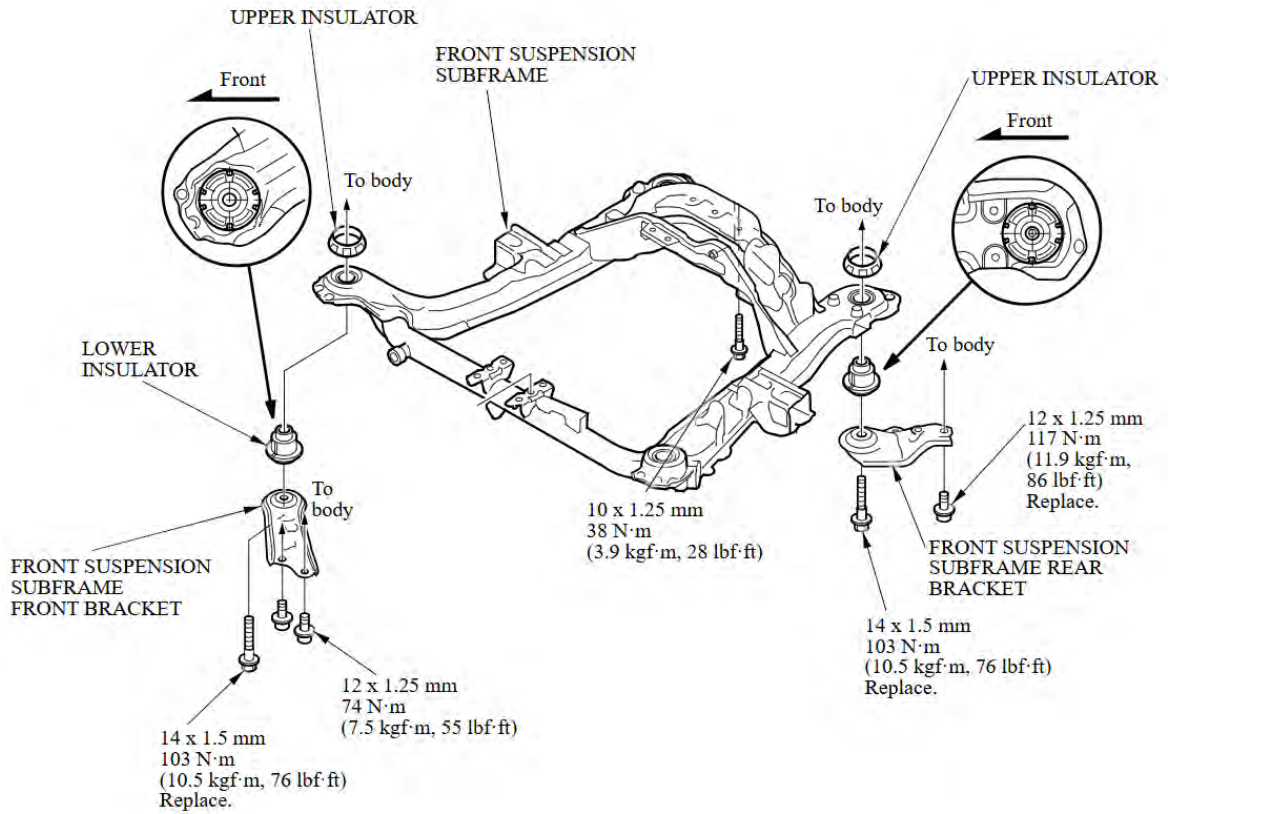

37. Install a new oil filter.
38. Install the bolts securing the oil pan to the transmission.

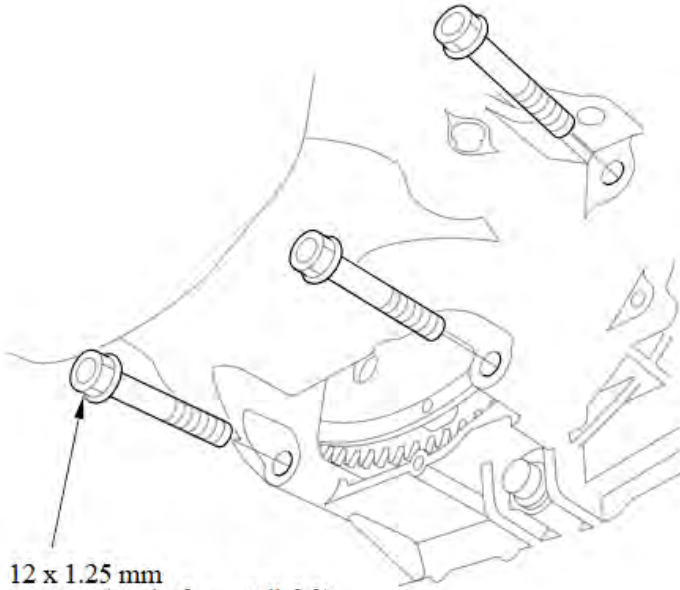

12 x 1.25 mm  
64 N·m (6.5 kgf·m, 47 lbf·ft)

39. Attach the torque converter to the drive plate (A) with eight bolts (B). Rotate the crankshaft pulley as necessary to tighten the bolts to half of the specified torque, then do the final torque in a crisscross pattern. After tightening the last bolt, check that the crankshaft rotates freely.

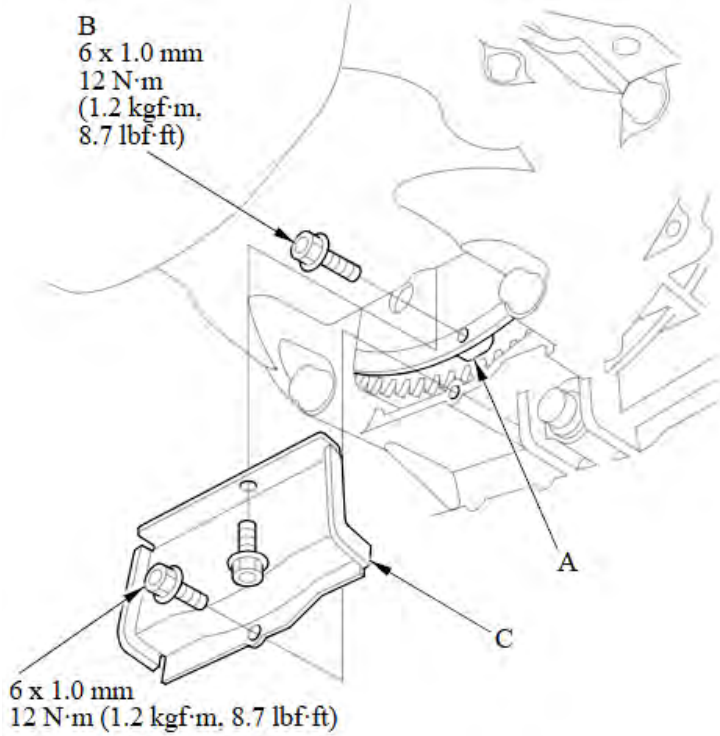

40. Install the torque converter cover (C).

41. Connect the rear engine mount actuator connector (D).

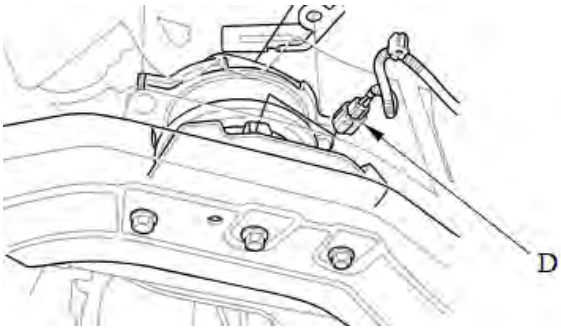

42. Connect front engine mount actuator connector (C).

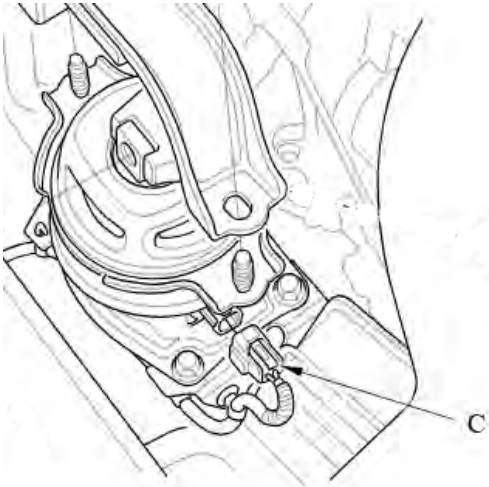

43. Connect the power steering pressure switch.

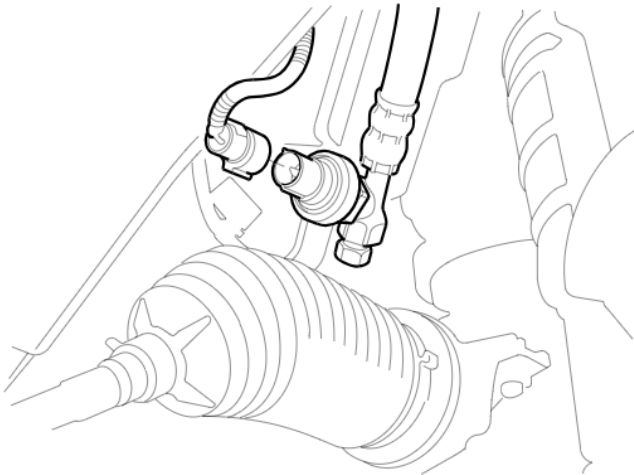

44. Connect the CKP connector (B) and install the cover (A).

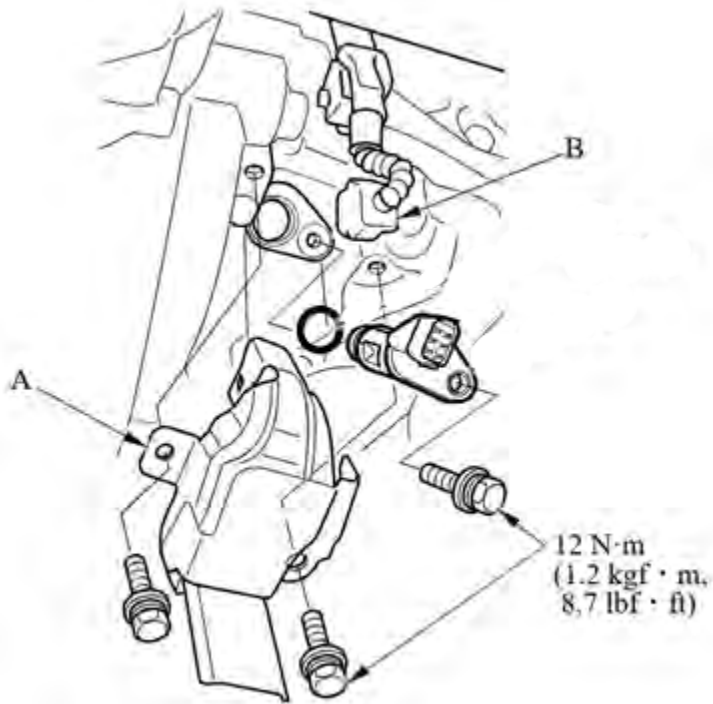

45. Install the left and right front dampers.

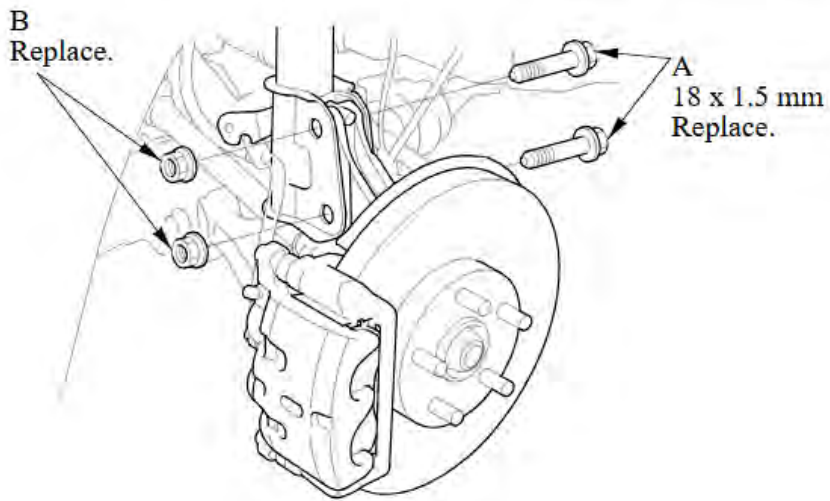

46. Connect the upper stabilizer links (A) to the dampers (B) and loosely install the flange nut (C). Then tighten the flange nut to the specified torque, while holding the joint pin (D) with the hex wrench (E).

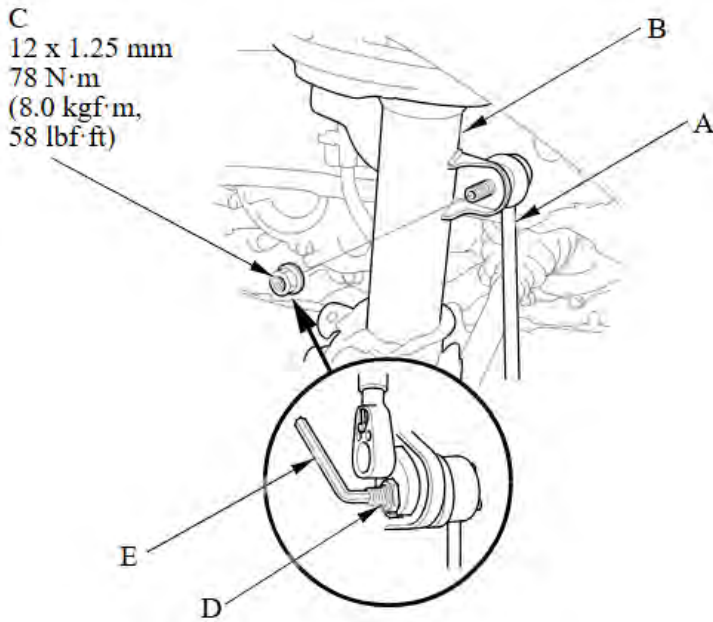

47. Install the left and right brake calipers (C) then install and tighten the caliper mounting bolts (B). Then install the brake hose mounting bolts (A).

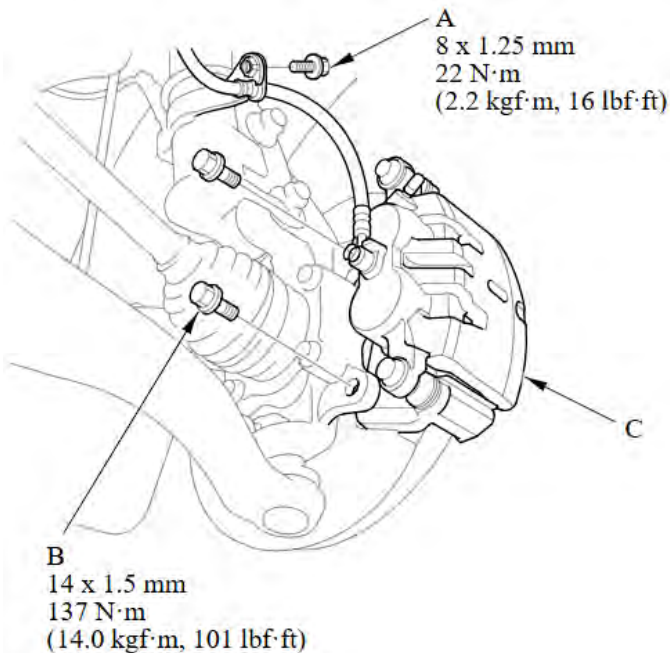

48. Install the wheel speed sensors and torque to **9.3 N·m (6.9 lb·ft)**.

49. Install the transmission ground and torque to **12 N·m (9 lb·ft)**.

50. Connect the power steering hose (A), and the ATF cooler hoses (B).

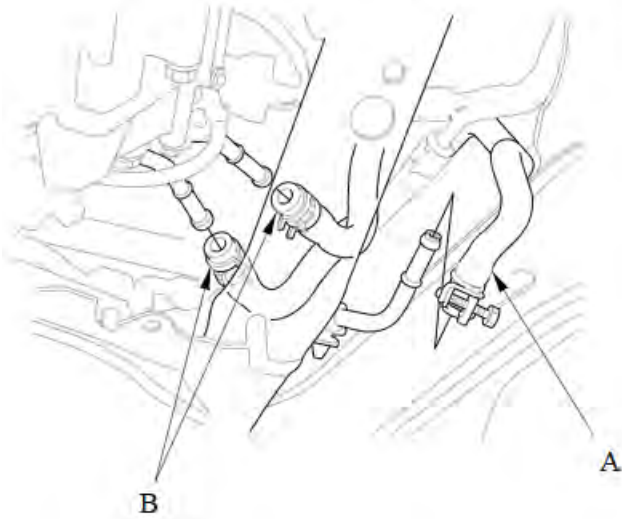

51. Install the front WU-TWC bracket.

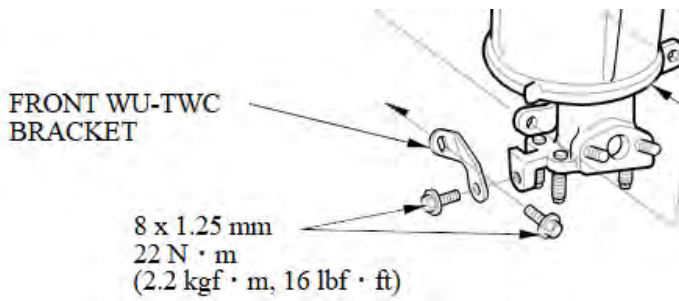

52. Install the rear WU-TWC bracket.

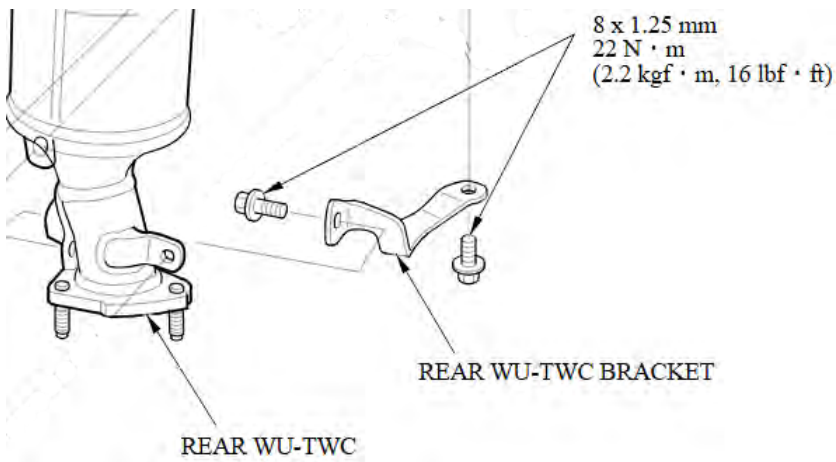

53. **With VTM-4 Only** – Install the transfer assembly.

NOTE: **For non-VTM -4 vehicles**, proceed to step 53.

1. Clean the area where the transfer assembly contacts the transmission with solvent, and dry with compressed air. Then apply transmission fluid to the seal contact area.
2. Install the dowel pin (A) in the transmission and install the transfer assembly (B) on the transmission.

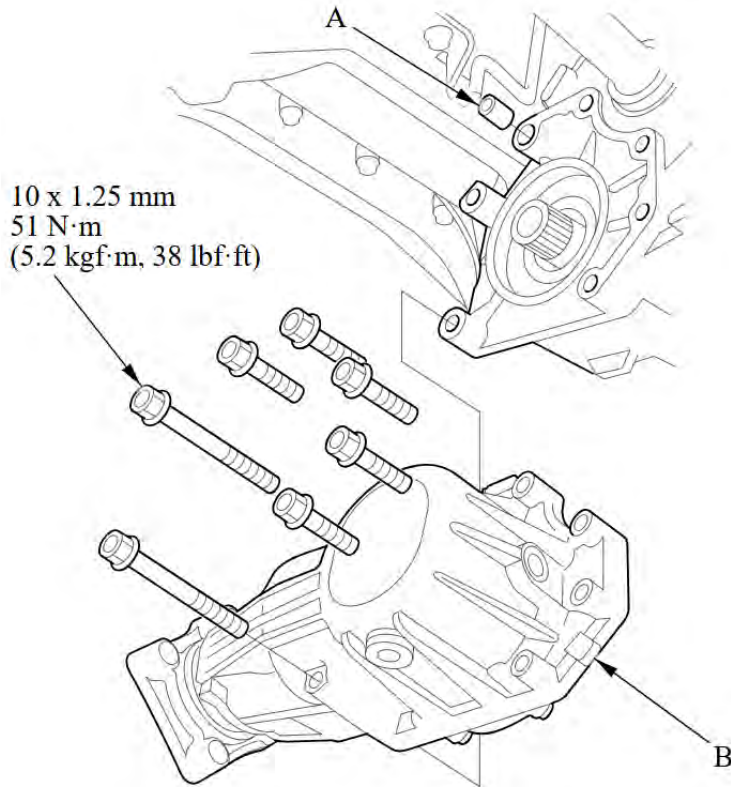

3. Install the propeller shaft (A) to the transfer companion flange (B) by aligning the reference mark (C). Make sure you use new mounting bolts.

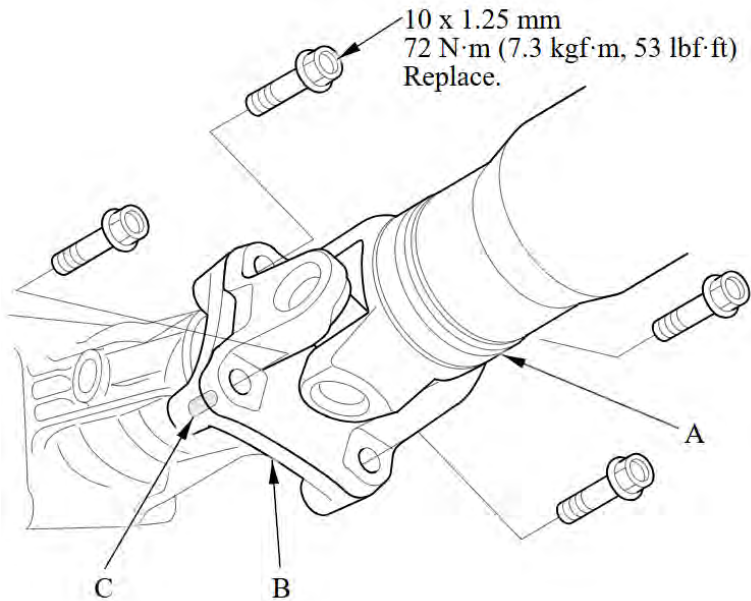

- Secure the transfer breather hose bracket (A) on the transfer assembly with the bolt, and connect the breather hose (B) over the breather pipe (C) with the dot mark (D) facing out.

6 x 1.0 mm  
12 N·m (1.2 kgf·m, 8.7 lbf·ft)

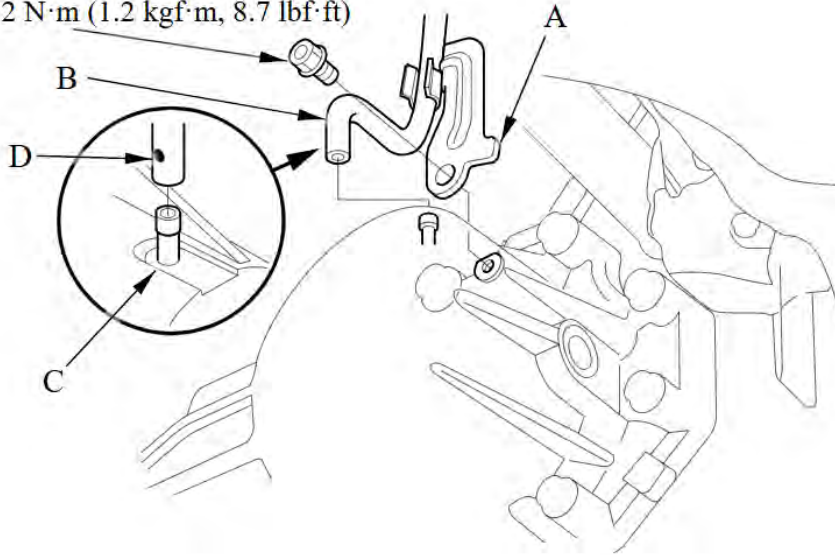

- Install exhaust pipe A.

NOTE: Use new gaskets (B) and new self-locking nuts.

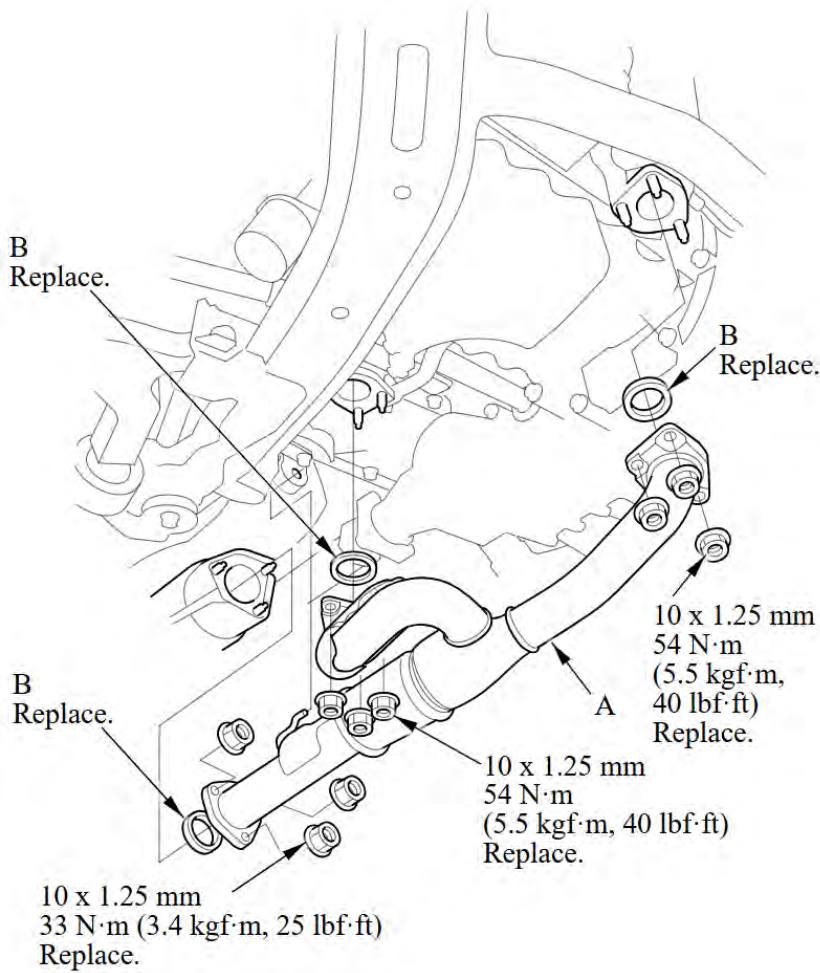

55. Install the front subframe suspension stiffener.

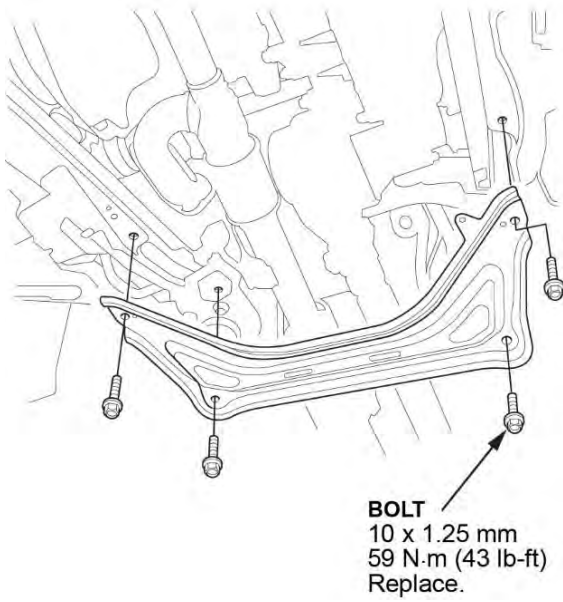

56. Lower the vehicle.

57. Install the alternator. Refer to the service manual for the full procedure.

58. Lift the vehicle to install the A/C compressor (A), then connect the A/C compressor clutch connector (B).

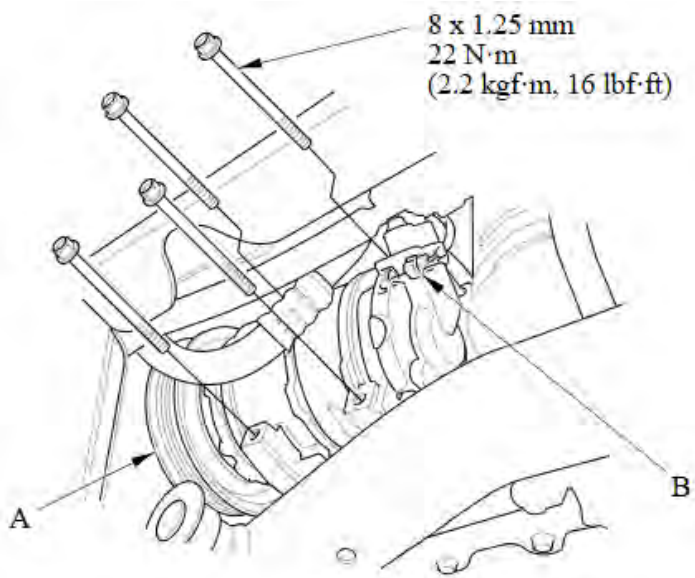

59. Install the drive belt auto tensioner.

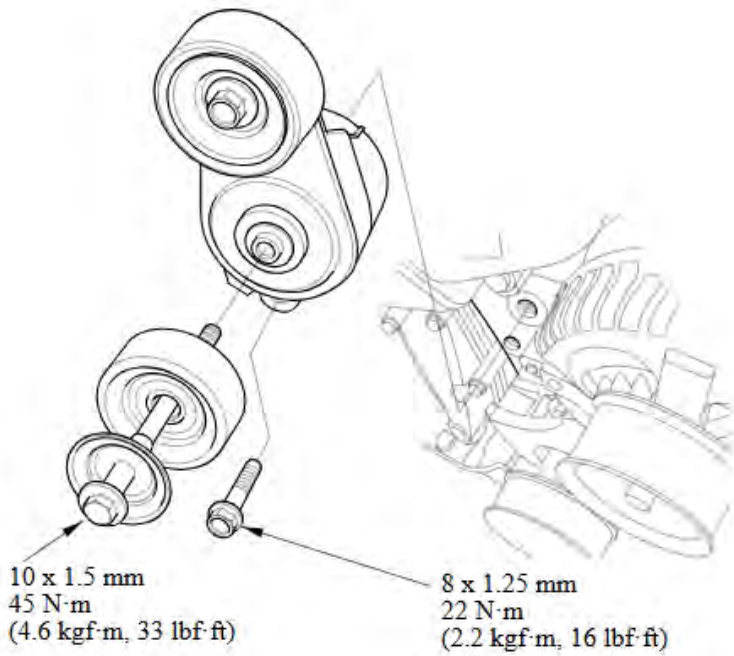

60. Install the power steering pump (A), then install the bolt (B) securing the power steering hose bracket (C).

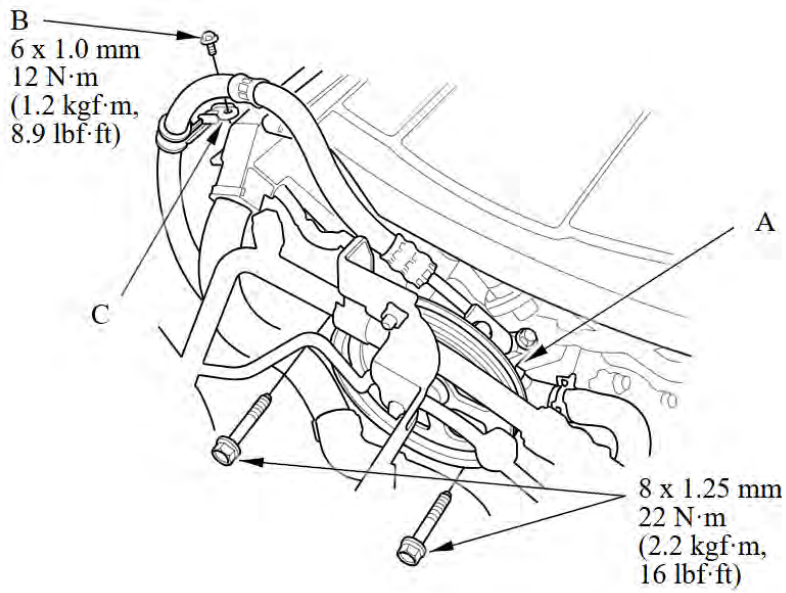

61. Connect the power steering pump inlet hose (C) and the power steering pump outlet hose (A) with a new seal (B) to the power steering pump. Attach the power steering hose bracket (D).

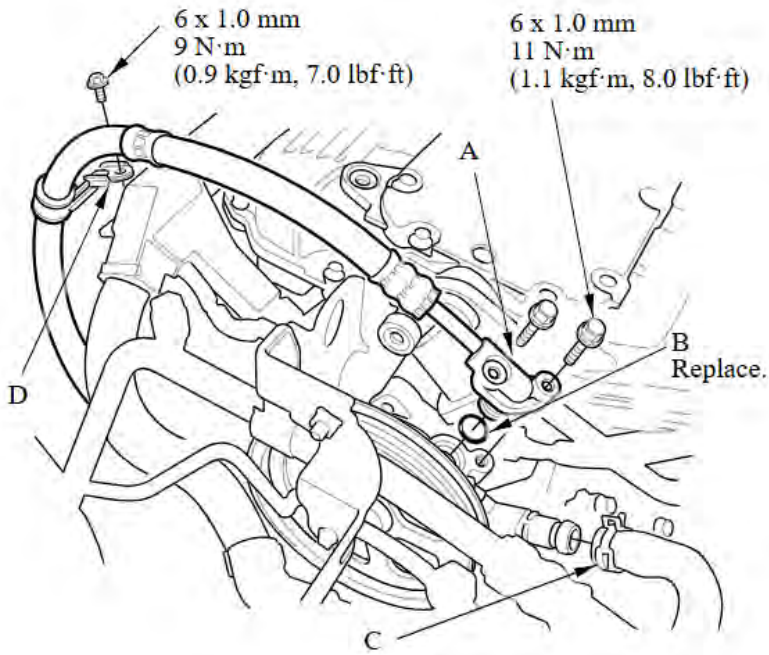

62. Install the drive belt.

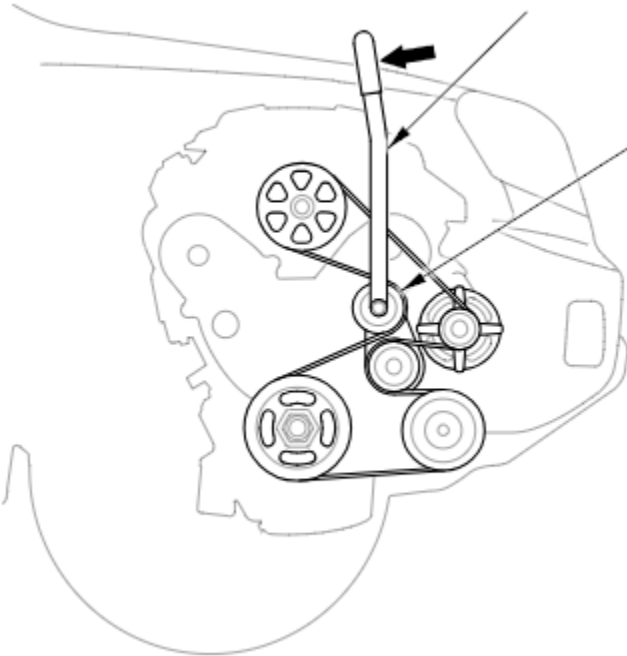

63. Install the side engine mount (A) and the wire harness bracket (B).

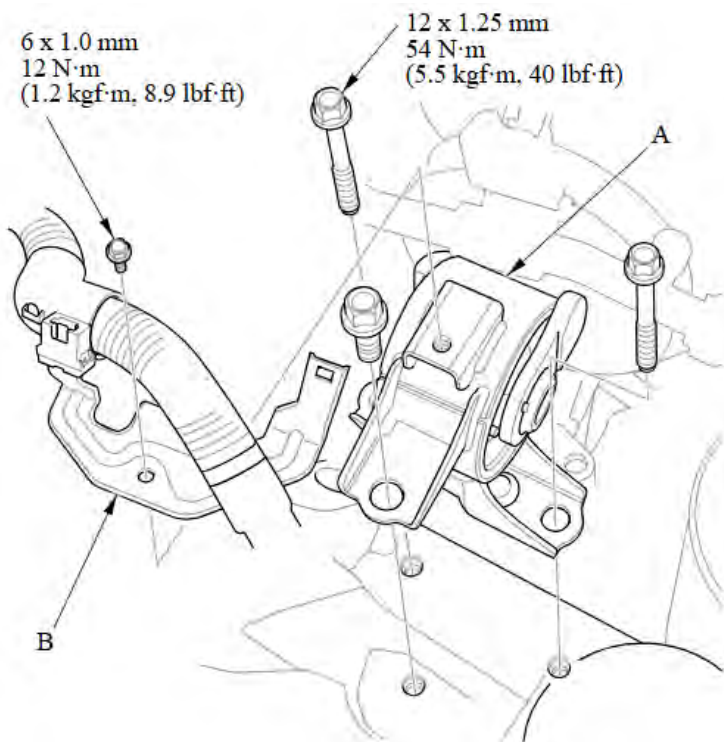

64. Install the upper half of the side engine mount bracket (A) using new bolts, then install the ground cable bracket (B).

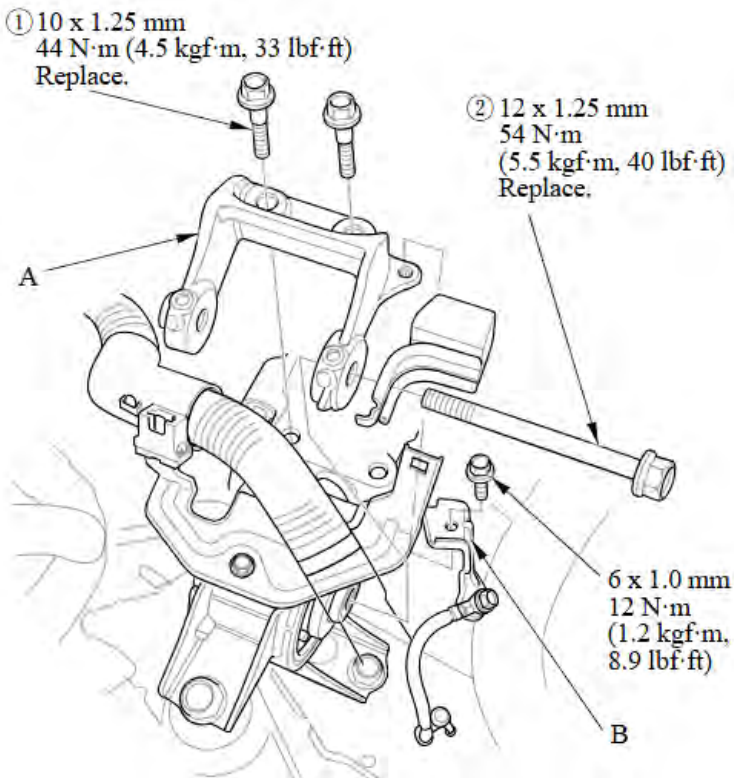

65. Install the PCM bracket, the harness clamps, and the engine wire harness connector, and torque the bracket bolts to **12 N·m (8.7 lb-ft)**.

66. Install the PCM and torque the mounting bolts to **9.8 N·m (7.2 lb-ft)**.

67. Install the PCM cover.

68. Connect the PCV hose (C), the brake booster vacuum hose (B), and the IMT actuator connector (A).

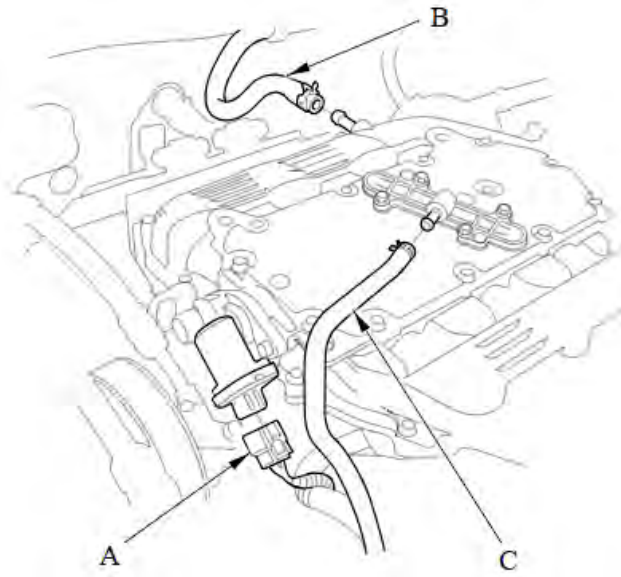

69. Connect the coolant bypass hoses (A). Then connect the EVAP canister hose (E), the EVAP canister purge valve connector (D), the throttle actuator connector (C), and the MAP sensor connector (B).

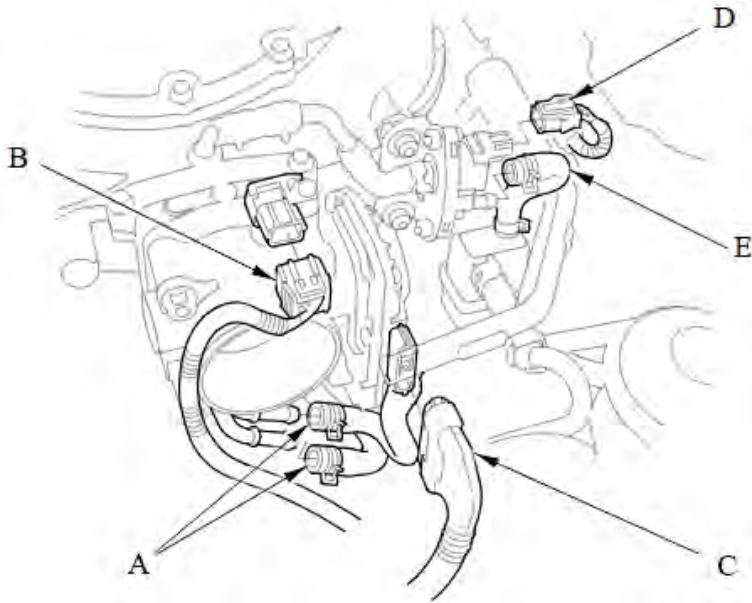

70. Install the EVAP canister purge joint with the bracket.

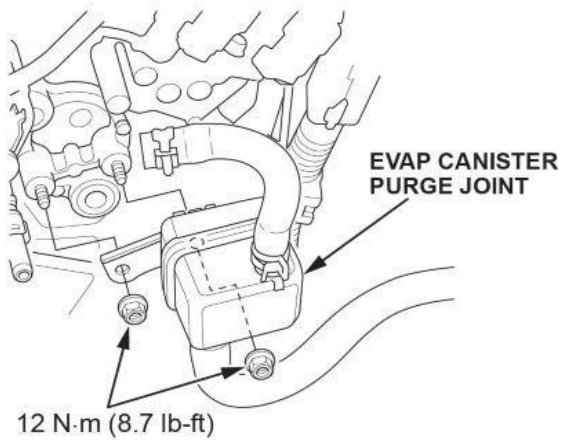

71. Connect the fuel feed hose (A), install the quick-connect fitting cover (B).

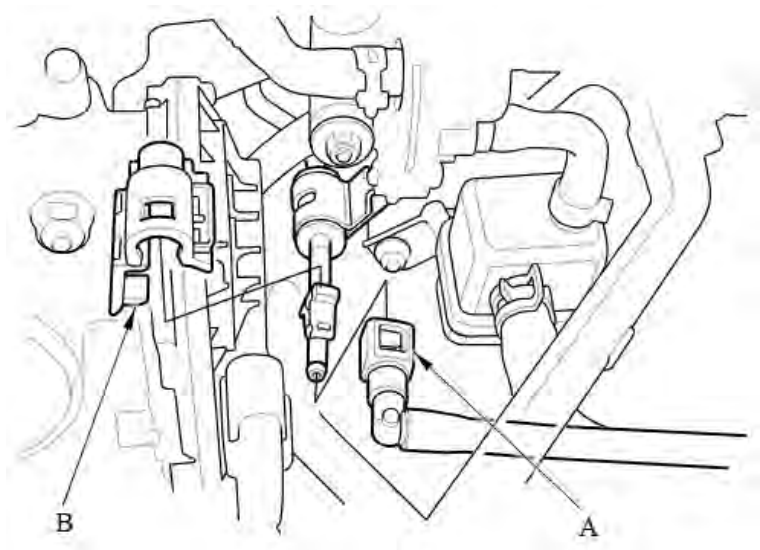

72. Connect the transmission shift cable.

1. Secure the shift cable bracket (C) with the nuts.
2. Attach the shift cable end (A) to the selector control lever (D), then insert the control pin (E) into the selector control lever hole, through the shift cable end, and secure the control pin with the spring clip (F).

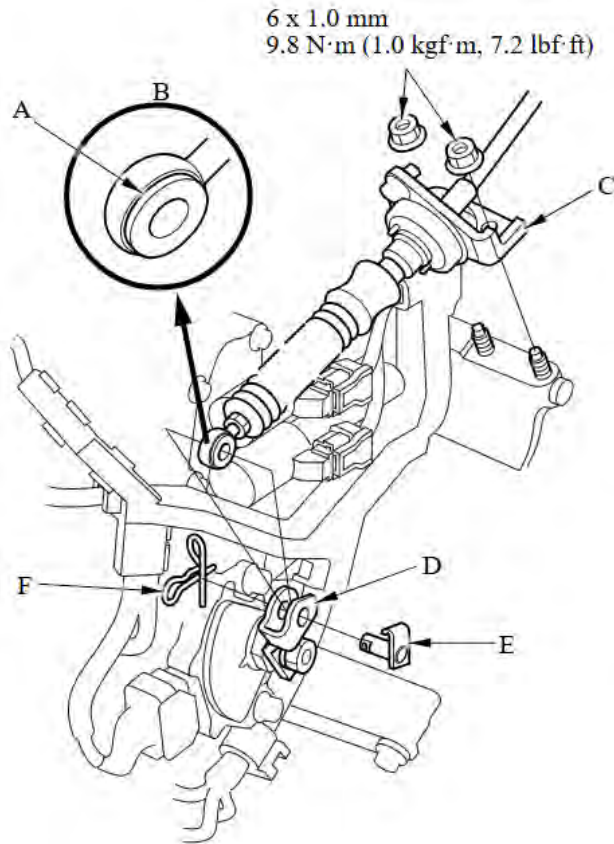

73. Install the Positive cable and nut on the starter and torque to **9.0 N·m (6.6 lb-ft)**

74. Connect the heater hoses

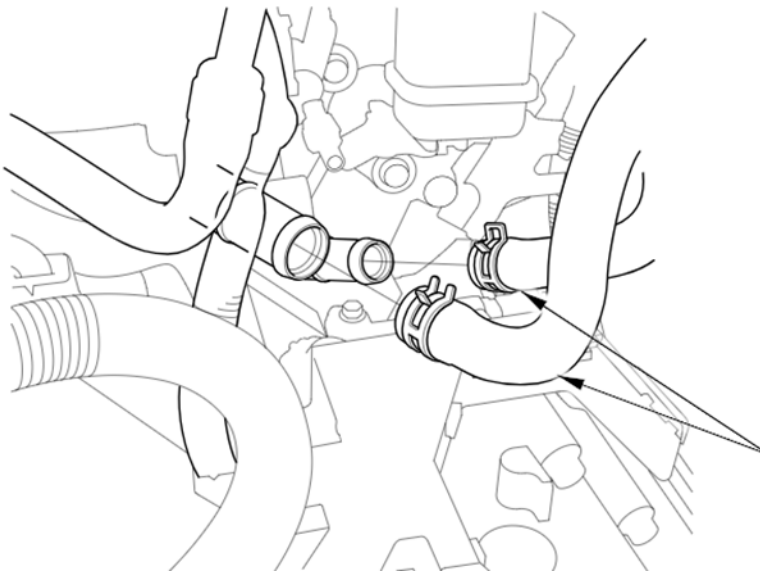

75. Connect upper and lower radiator hoses.

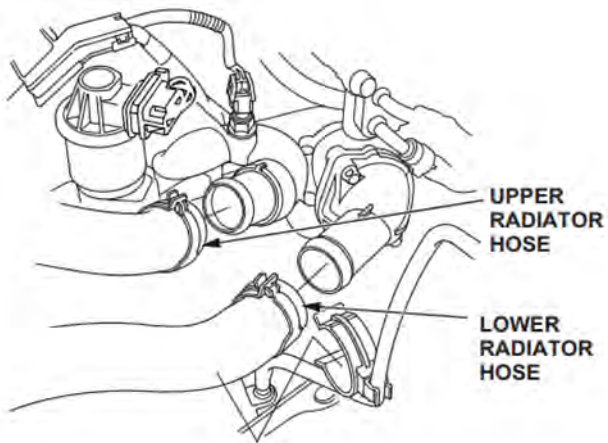

76. Install the battery base (A), and the harness clamps (B), then tighten the mounting bolts.

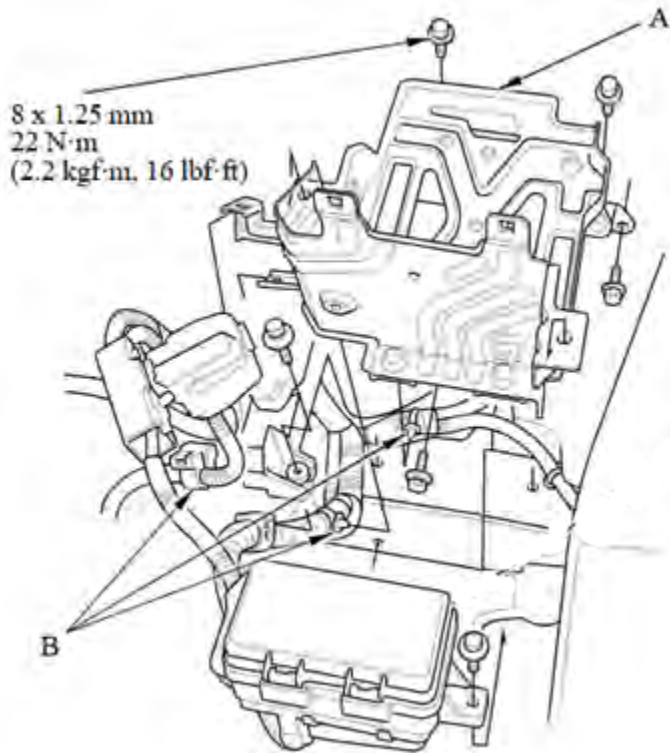

77. Install the main under-hood fuse box (A) and the harness clamps (B), then connect the engine wire harness (C) and starter cables (D) to the main under-hood fuse box.

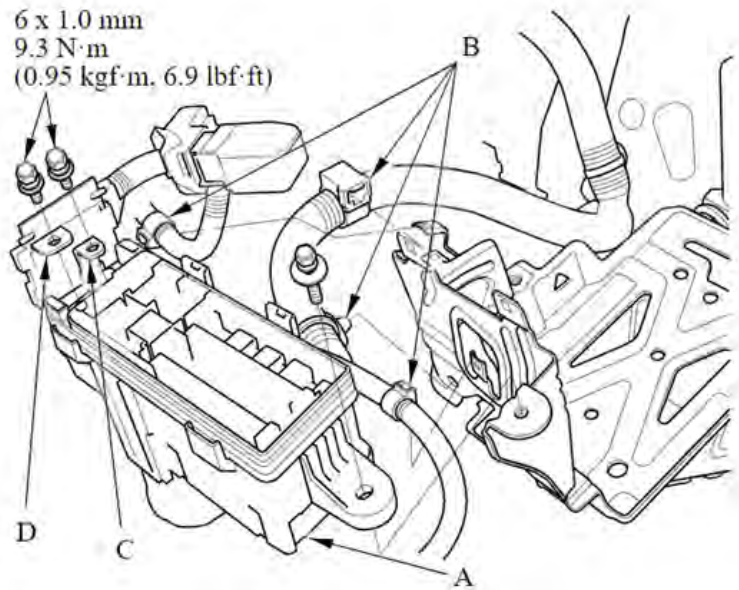

78. Do the 12 Volt Battery Installation procedure. Refer to the service manual for the full procedure.
79. Install the air cleaner.
80. Install the engine cover.
81. Lift the vehicle.
82. Install the inner fender liners.
83. Install the splash shield.
84. Install the front wheels and torque to **127 N·m (94 lb-ft)**.
85. Lower the vehicle.
86. Align the bolt hole (A) on the steering joint with the groove (B) around the pinion shaft, then loosely install the joint bolt (C). Be sure that the joint bolt is securely in the groove in the pinion shaft. Torque the joint bolt to specification.

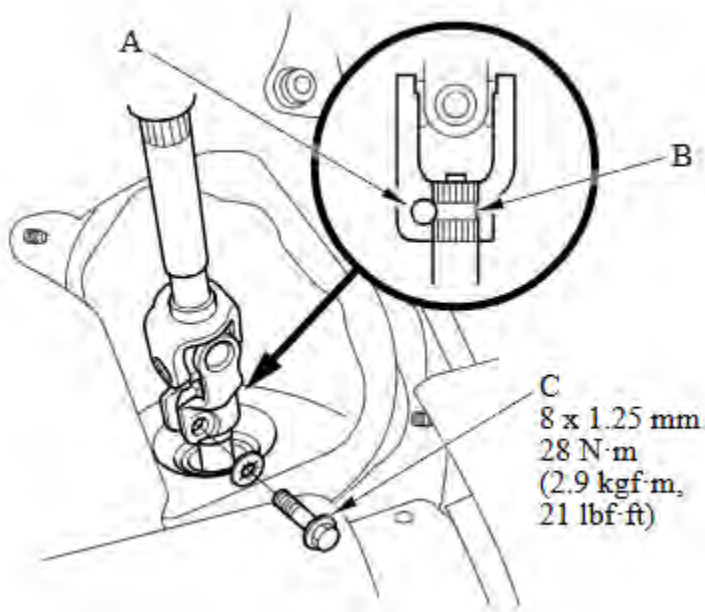

87. Refill the engine with engine oil.

**After Engine Overhaul: 5.0 L (5.3 US qt)**

88. With the ignition in the ON mode (key on with engine OFF), move the shift lever to each gear and verify that the A/T gear position indicator follows the transmission range switch. Then turn the ignition to the OFF mode.

89. Refill the power steering reservoir with power steering fluid.

90. Refill the radiator with engine coolant.

91. Refill the transmission fluid.

NOTE: **Do not** overfill the transmission with ATF.

**With ATF Cooler: 3.4 L (3.6 US qt.) at change**

**Without AFT Cooler: 3.1 L ( 3.3 US qt) at change**

92. Inspect for fuel leaks. Turn the ignition switch to ON (II) (do not operate the starter) so the fuel pump runs for about 2 seconds and pressurizes the fuel line. Repeat this operation three times, then check for fuel leakage at any point in the fuel line.

93. Check the PCM software version P/N located above the PGM-FI Data List.

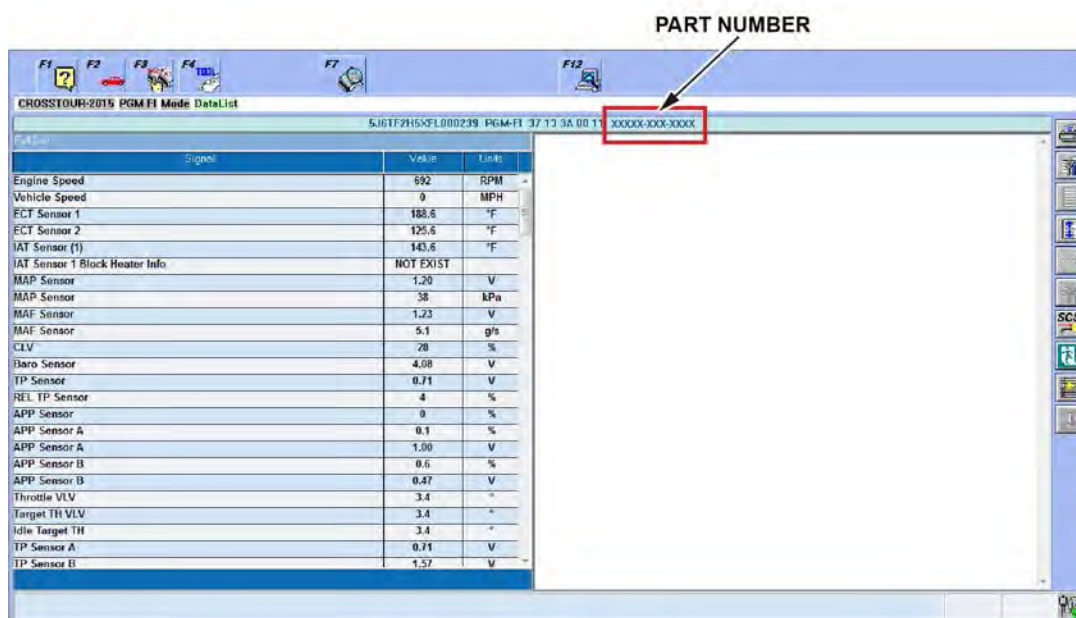

Year	Trim	Software System	New Program ID
2013–2014	Pilot (2WD)	PGM-FI	37805-RN0-M050
2013–2014	Pilot (4WD)	PGM-FI	37805-RN0-M950
2015	Pilot (2WD)	PGM-FI	37805-RN0-M140
2015	Pilot (4WD)	PGM-FI	37805-RN0-M840

94. Do the PCM update, if needed.

NOTE: For information on updating the PCM see service bulletin [22-100 Updating Control Units/Modules with the Honda ECU Reprogramming Application](#).

Is the PCM Program ID and/or Program P/N the same or newer than what is listed above?

**NO** – Update the PCM software.

**YES** – The correct software is installed; no update is needed.

95. Do the idle learn procedure.
96. Do the CKP pattern clear/CKP pattern learn procedure.
97. Do the cooling system bleeding procedure.
98. Raise the vehicle.
99. Check for fluid leaks.
100. Lower the vehicle
101. Check the wheel alignment.
102. Perform a road test.