



Technical Service Bulletin

GROUP	NUMBER
CAMPAIGN	25-01-046G
DATE	MODEL(S)
JULY 2025	G70 (IK)

SUBJECT: REAR CORNER RADAR UNIT REPLACEMENT
(SERVICE CAMPAIGN T79G)

* IMPORTANT

Retailers must perform this service campaign on all affected vehicles prior to retail delivery to a guest and whenever an affected vehicle is in the shop for any maintenance or repair.

Access the “Vehicle Information” screen via WebDCS to identify open campaigns.

Description: Certain G70 (IK) vehicles may exhibit communication issues with the Blind-Spot Collision Warning System caused by the Rear Corner Radar units. This bulletin contains instructions on replacing the Rear Corner Radar units (LH/RH), performing radar calibration, and variant coding.





Applicable Vehicles (Certain):

- 2025–2026MY G70 (IK) produced from 02/08/2025–03/28/2025

Parts Information:

Model	Part Name	Part Number	Figure	Remarks
G70 (IK)	L/H Rear Corner Radar Module	99140-G9510QQH	 	Part number suffix “QQH” is displayed on the part label
	R/H Rear Corner Radar Module	99150-G9510QQH	 	

SST Information:

Tool Name	Tool Number	Figure	Remarks
BCW Unit Correction Tool Set	09958-3T500 (Contains SSTs listed below)		<p>BCW Unit Correction Tool Set contains:</p> <ul style="list-style-type: none"> • Laser Level • Vertical Plumb • BCW Unit Fixing Adaptor • Digital Protractor • Digital Inclinator • Case and Manual and String <p>Retailers should already have this complete kit on-hand.</p> <p>Kits and replacement tools can be ordered as needed.</p> <p>Ordering Information: Website: https://genesisessentialtools.com/ Phone: 1-855-763-6630 Email: Genesisistools@snapon.com Hours: 7 AM – 7 PM CST</p>
Laser Level	09958-3T070		
Vertical Plumb	09958-3T010		
BCW Unit Fixing Adaptor	09958-3T080		
Digital Protractor	09958-3T090		
Digital Inclinator	09958-3T100		
Case and Manual and String (locally supplied string may be used instead)	09958-3T120		

SST Information (Continued):

Tool Name	Tool Number	Figure	Remarks
VCI 3	G0VPNNN006		Ordering Information: Website: https://genesisessentialtools.com/ Phone: 1-855-763-6630 Email: Genesisistools@snapon.com Hours: 7 AM – 7 PM CST
VCI 2	G1XDDMN002		

Warranty Information:

Model	Op. Code	Operation	Op. Time	Causal Part	Nature Code	Cause Code
G70 (IK)	50D124R0	Rear Corner Radar Unit Replacement (both LH and RH), Radar Calibration, and Variant Coding	1.3 M/H	99140-G9510	W11	ZZ3

NOTE 1: Submit claim on Claim Entry Screen as “Campaign” type.

NOTE 2: If a part is found in need of replacement while performing this campaign and the affected part is still under warranty, submit a separate claim using the same repair order. If the affected part is out of warranty, submit a Prior Approval request for goodwill consideration prior to performing the work.

NOTE 3: This TSB includes repair validation photos. Op times include VIN, Mileage, and Repair validation photo(s) as outlined in the Digital Documentation Policy.

NOTE 4: The incident parts are subject to callback through the normal Warranty Technical Center (WTC) parts return process. **Claim is subject to debit if the part is not returned.**

Service Procedure:**DIGITAL DOCUMENTATION**

This TSB includes repair validation photos. Refer to the latest Warranty Digital Documentation Policy for requirements.

NOTICE

Applying the recommended torque to all fasteners is essential to reduce potential issues from occurring after the service procedure.

Table of Contents

- Variant Coding Value Check 4
- Battery Negative (-) Terminal Disconnection..... 7
- Rear Bumper Removal..... 8
- Rear Corner Radar Removal and Installation..... 12
- Rear Corner Radar Unit Angle Adjustment 13
- Rear Corner Radar Calibration..... 17

Variant Coding Value Check

1. Connect the VCI 2 or 3 (A) to the data link connector in driver side crash pad lower panel and open the Genesis Smart application.

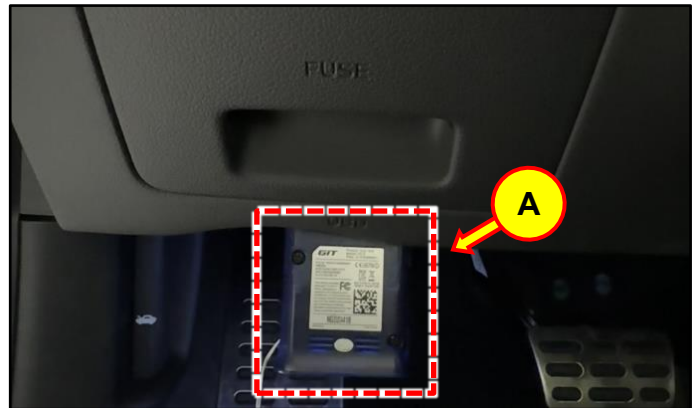

2. Select the vehicle model and **S/W Management (B)**.

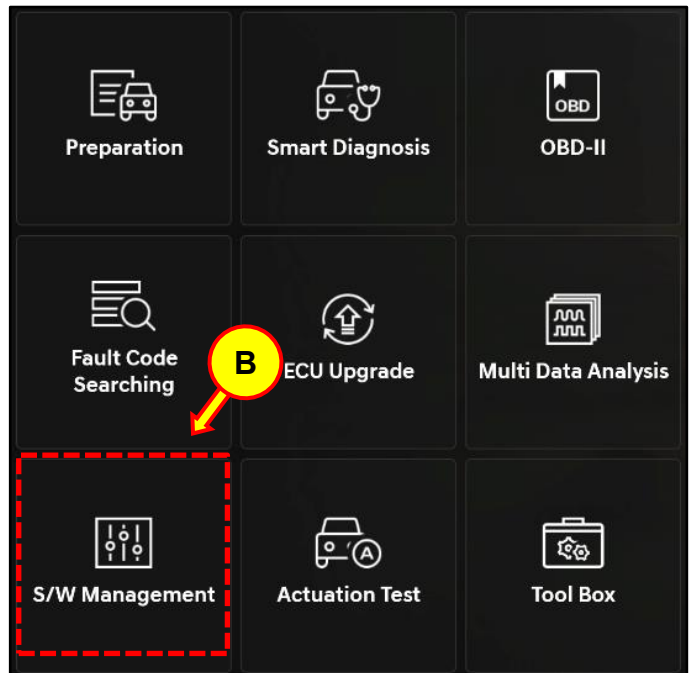

3. Select **RR_C_RADAR_R - Rear Corner Radar-Right (C) > Variant Coding (D)**.

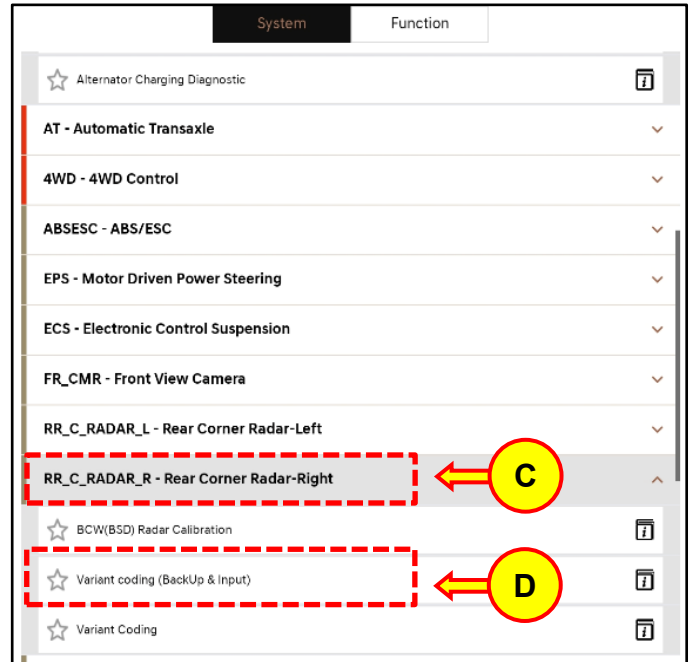

4. Check the **Purpose** and **Enable Conditions** and select the **Run** button (E).

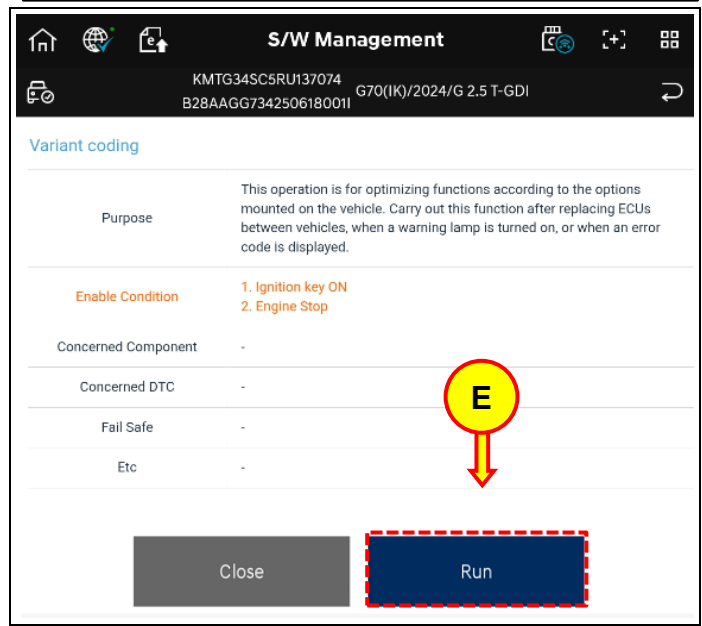

- Ensure the conditions are met and select the **OK** button (F).

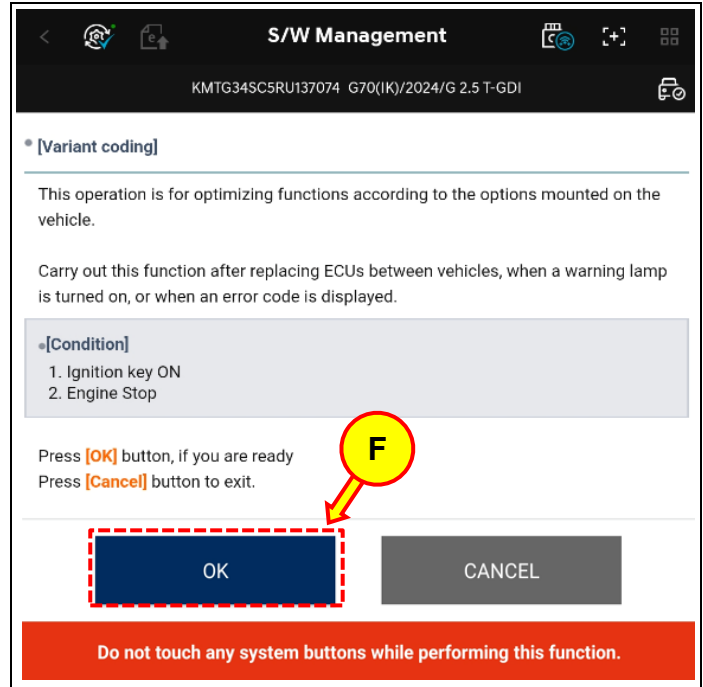

- Select **Manual** (G).

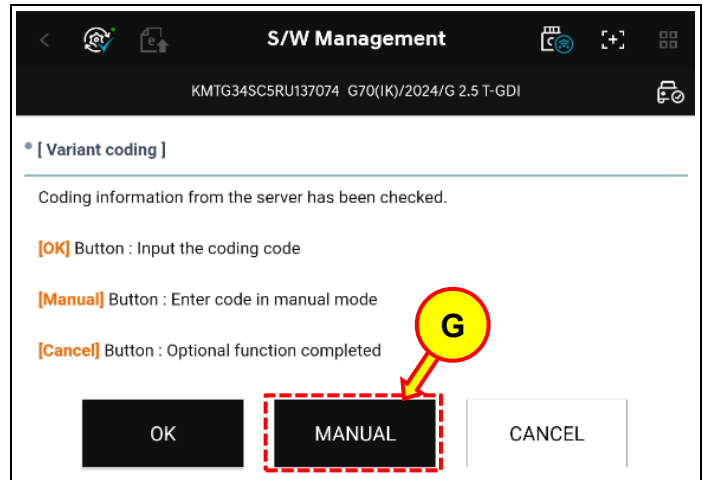

- Check the **Current coding value** (H) and write it down for future reference.

Select **OK** (I).



Information

This step is critical to entering the variant coding value in a future procedure and must be performed.

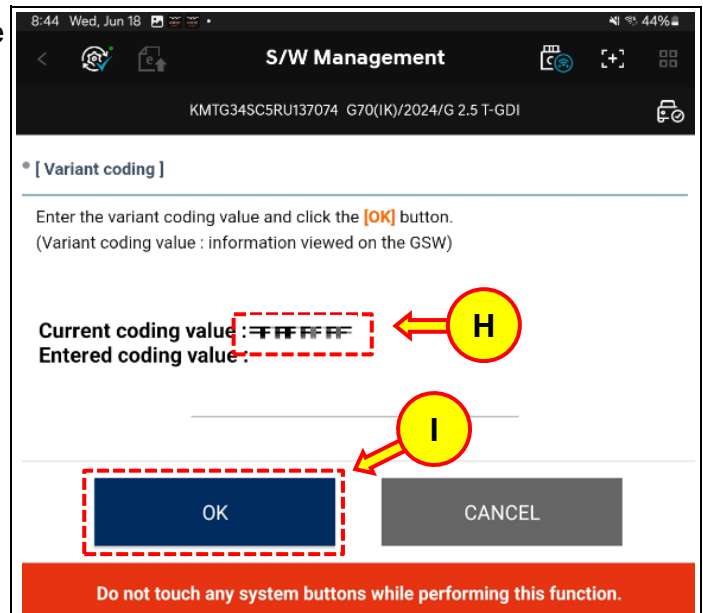

8. Select **RR_C_RADAR_L - Rear Corner Radar-Right (J)** and repeat **steps 4–7**.

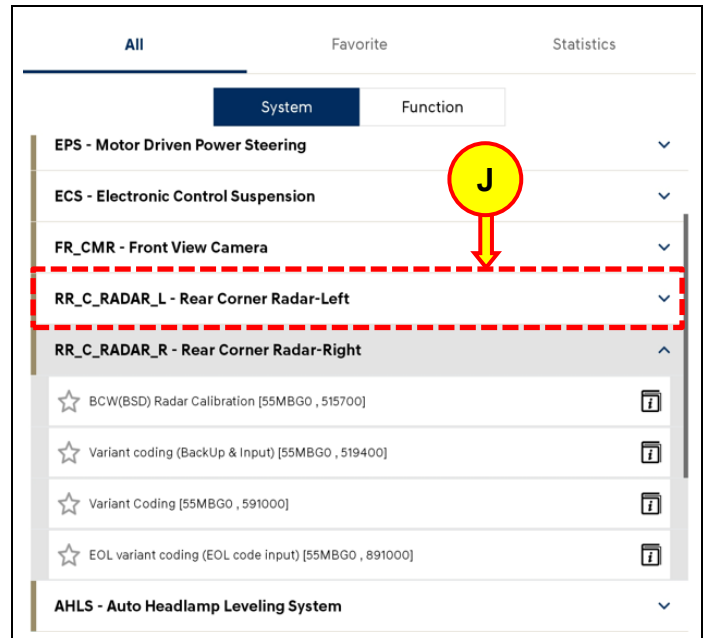

9. When finished recording both left and right radar variant coding values, continue to **Battery Negative (-) Terminal Disconnection**.

Battery Negative (-) Terminal Disconnection

1. Turn the ignition switch OFF.
2. Remove the luggage covering (A).

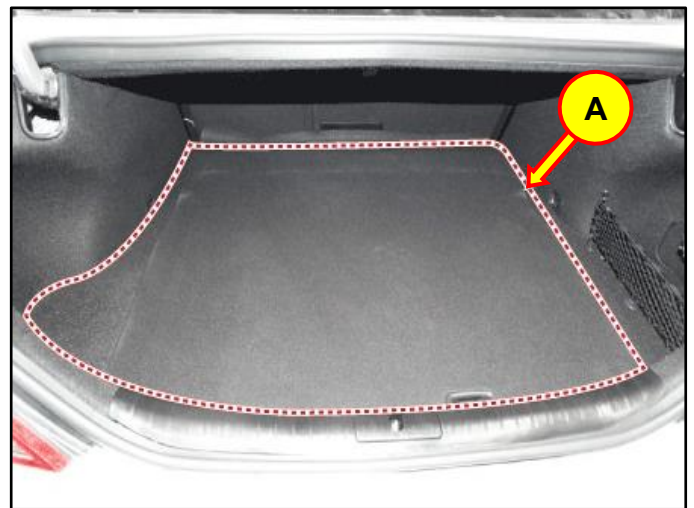

3. Remove the luggage center tray (B).

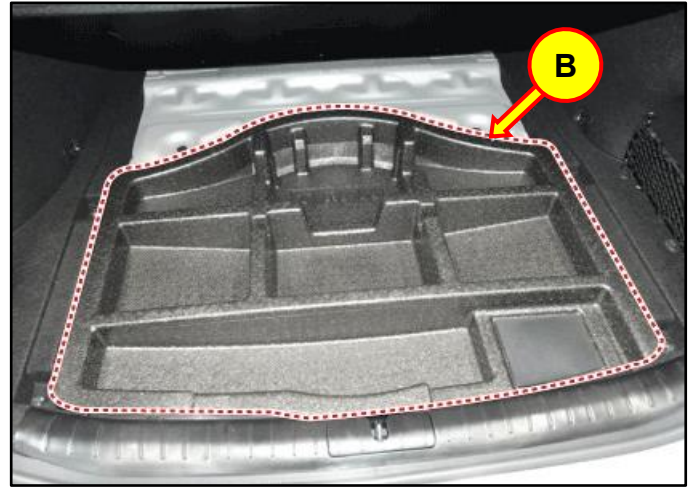

4. Turn the ignition switch OFF and disconnect the battery negative (-) terminal (C).

Tightening Torque:

lb-ft	6.5
lb-in	78
N.m	9

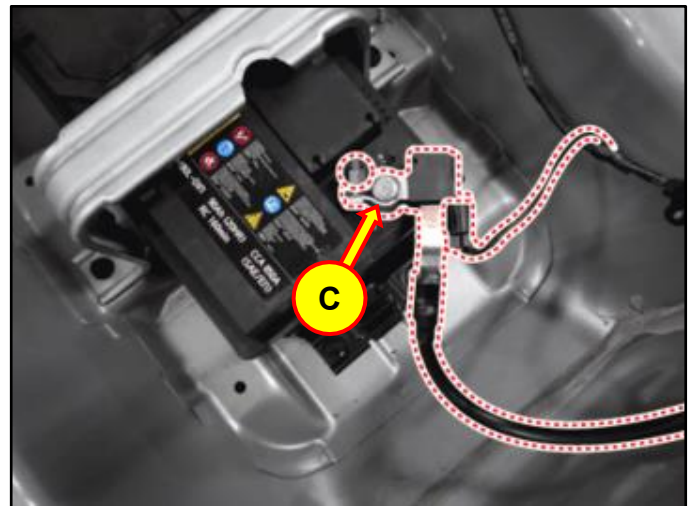

Rear Bumper Removal

1. Remove the luggage side trim (A).

Refer to the shop manual:

- **Body (Interior and Exterior) > Interior Trim > Luggage Side Trim > Repair Procedure.**

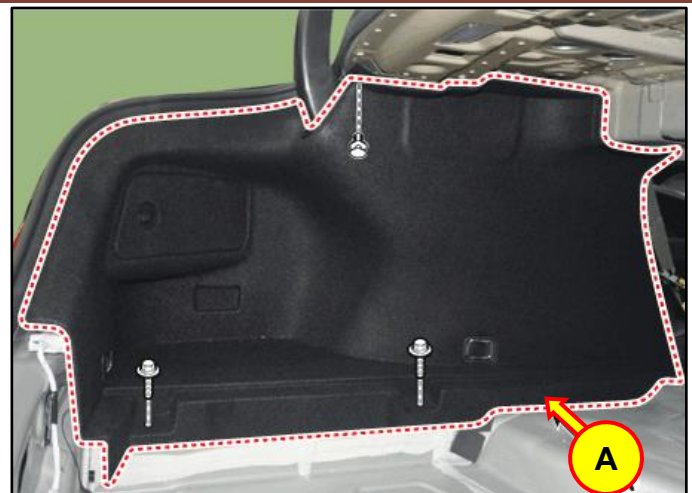

2. Disconnect the rear combination lamp connector (B), remove the mounting nuts, and remove the rear combination lamp (C).

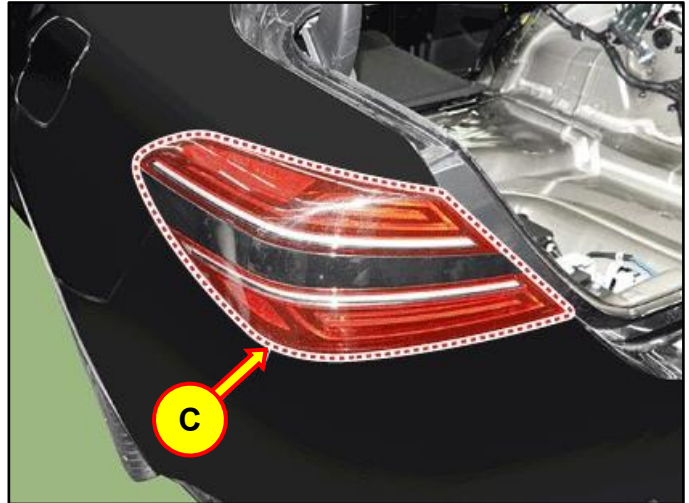
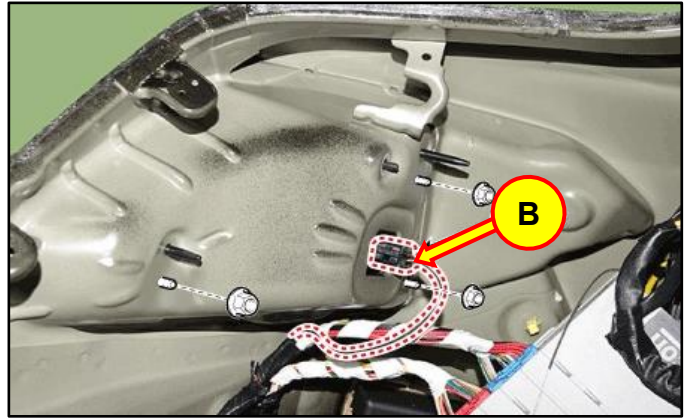

3. Remove the rear bumper upper mounting pin-type retainers (D) and screws (E).

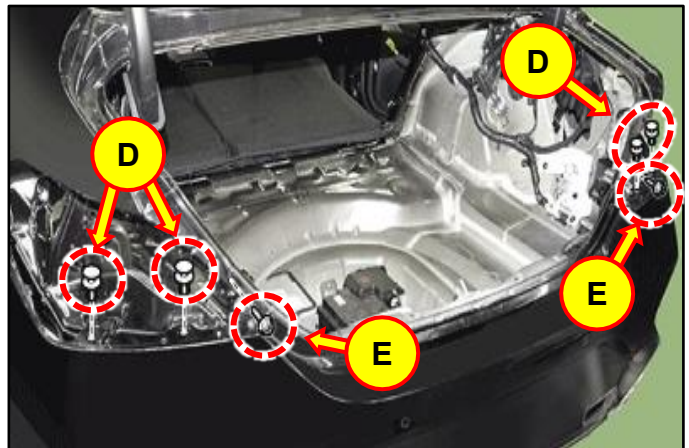

4. Remove the rear bumper mounting bolts (F).

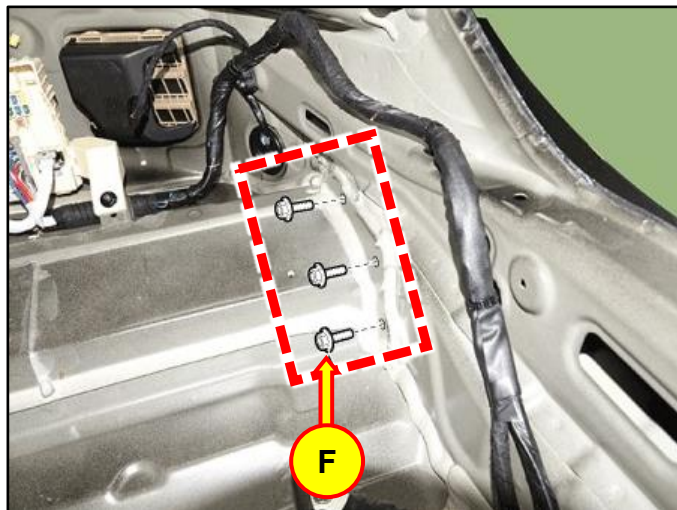
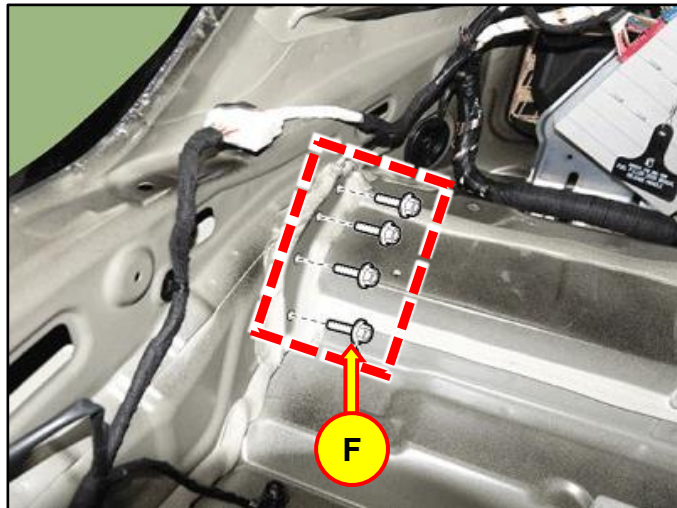

5. Remove the rear bumper lower mounting pin-type retainers (G).

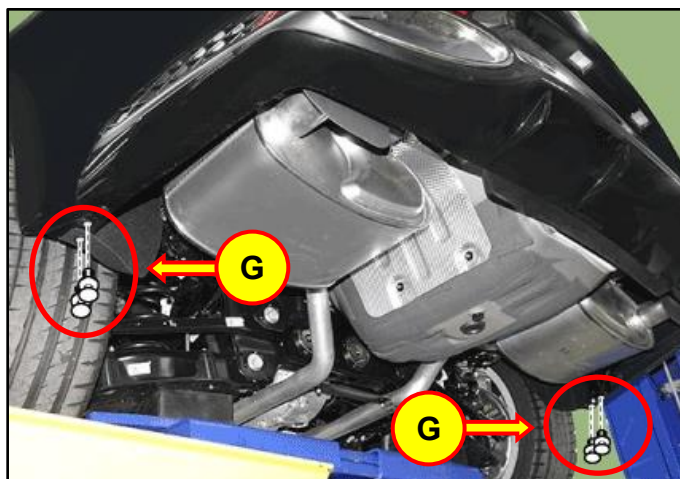

6. Remove the pin-type retainers and screws (I) on the side of rear bumper. Then, detach the side part of the rear bumper (J).

NOTICE

- Be careful **NOT** to damage the tabs on the side part of rear bumper.
- Loosen the screws equally from side to side.
- Remove the rear bumper, taking care **NOT** to damage the locking jaw by holding the lower part (No. 1) of the rear bumper and pulling the rear quarter and bumper (No. 2).

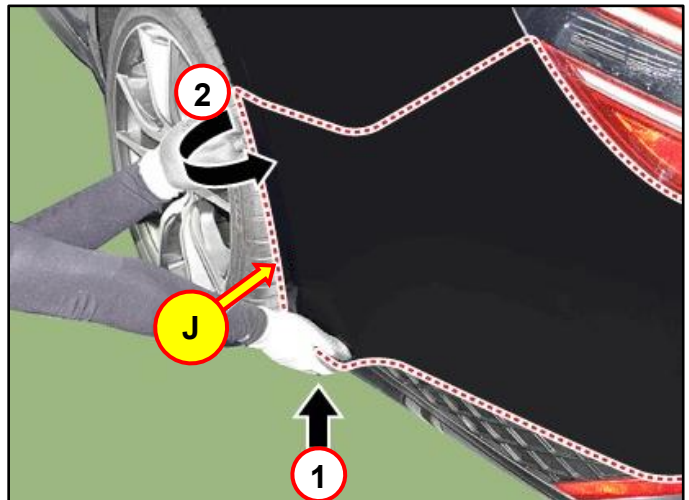
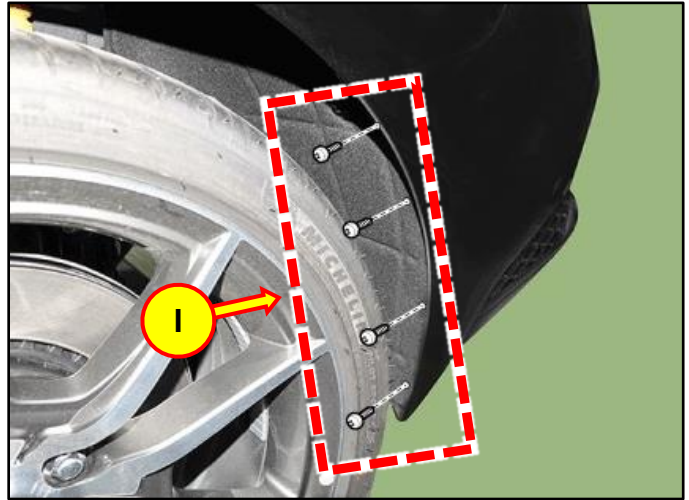

7. Disconnect the rear bumper connector (K).

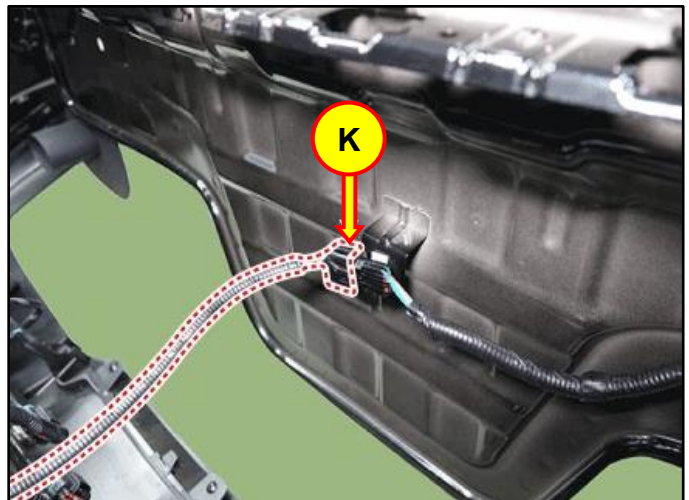

8. Remove the rear bumper assembly (L).

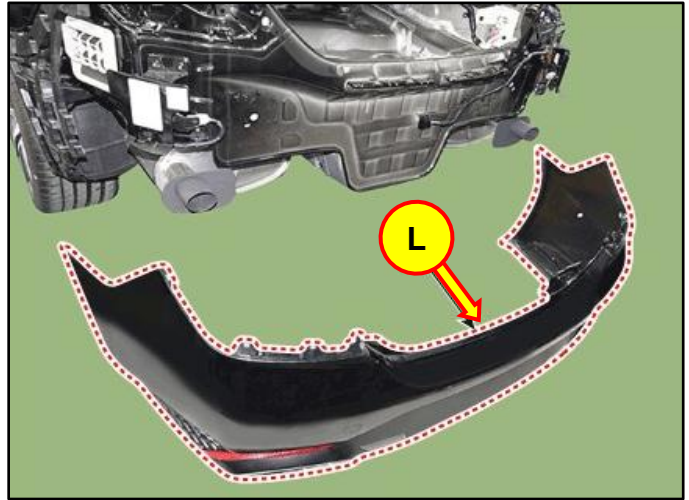

Rear Corner Radar Removal and Installation

1. Disconnect the LH and RH rear corner radar connectors (A).



2. Remove the mounting nuts (B) and remove the LH and RH rear corner radar units (C).

Tightening Torque:

lb-ft	6.5
lb-in	78
N.m	9

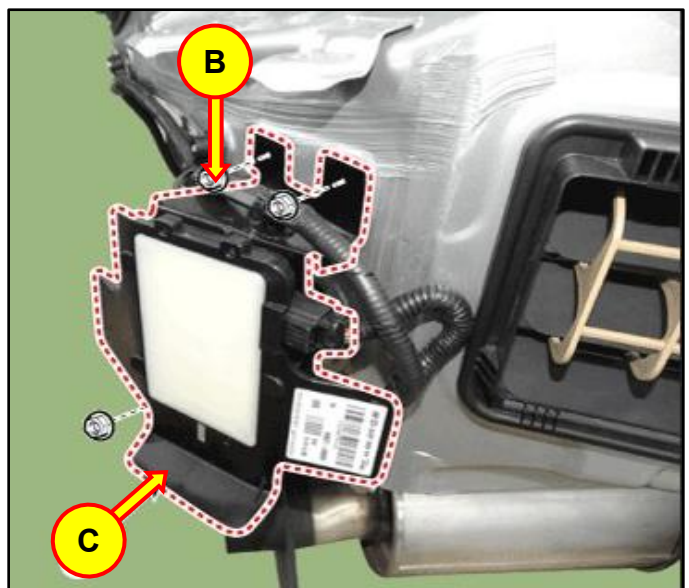

3. Install and connect the new LH and RH rear corner radar units in the reverse order of removal.

NOTICE

Ensure you install the left and right units in the correct locations.

Rear Corner Radar Unit Angle Adjustment

i Information

After replacing the rear corner radar unit, with the bumper removed, use the BCW Unit Correction Tool Set to perform angle correction. If you are missing any of the contained SSTs, you can reorder a complete set or individual tools.

BCW Unit Correction Tool Set:

- SST 09985-3T500



1. Attach the Vertical Plumb SST to the hood and lower the plumb to just above the ground (A), so it passes through the center of the emblem.

i Information

Vertical Plumb:

- SST 09958-3T010

i Information

Due to the aluminum hood on G70 vehicles, it may be difficult to keep the magnetic plumb anchor from sliding while attempting to find the centerline in the front. Use locally supplied painter's tape to prevent from sliding (B).

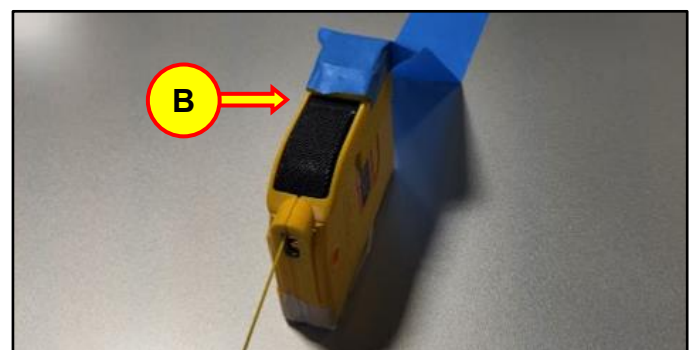
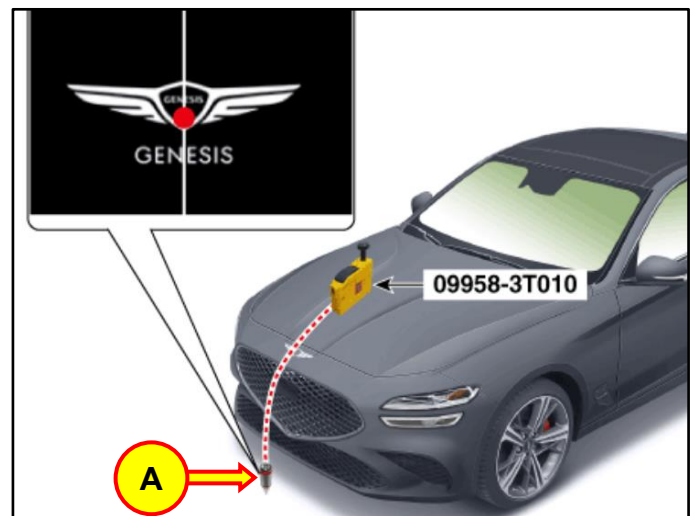

- Place a piece of tape on the ground under the plumb and mark the center point using a pen or marker (C).

i Information

Let the plumb's movement stop completely before marking the center point.

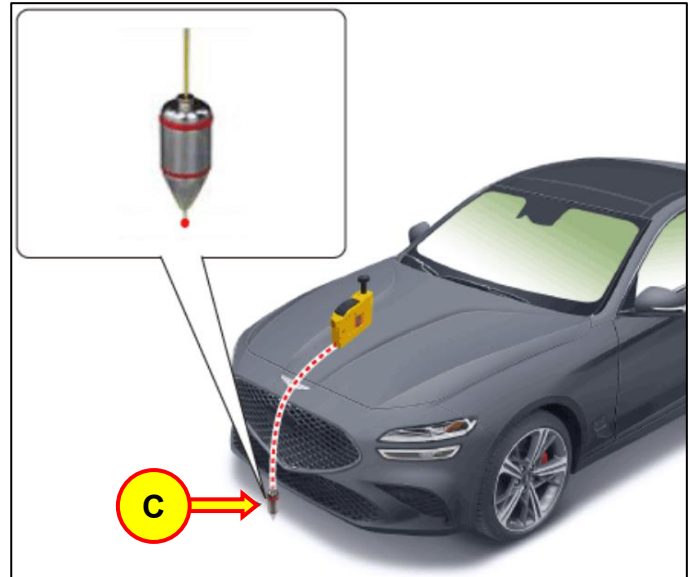

- Attach the vertical plumb on the trunk and lower the plumb (D) to just above the ground, so that it passes through the center of the emblem.

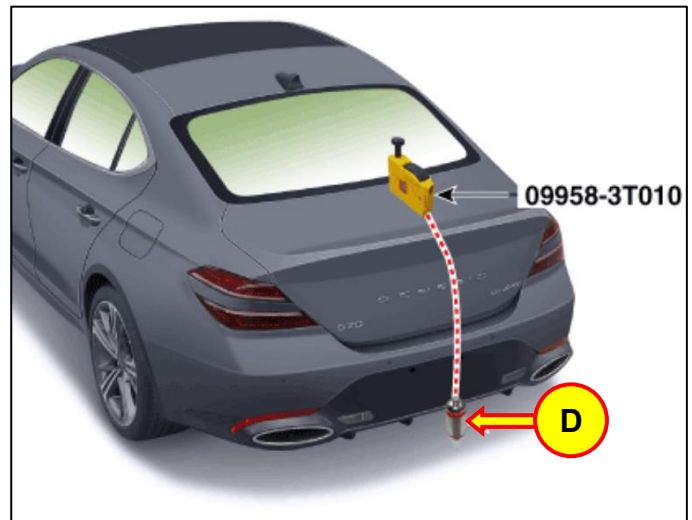

- Place a piece of tape on the ground under the plumb and mark the center point using a pen or marker (E).

i Information

Let the plumb's movement stop completely before marking the center point.

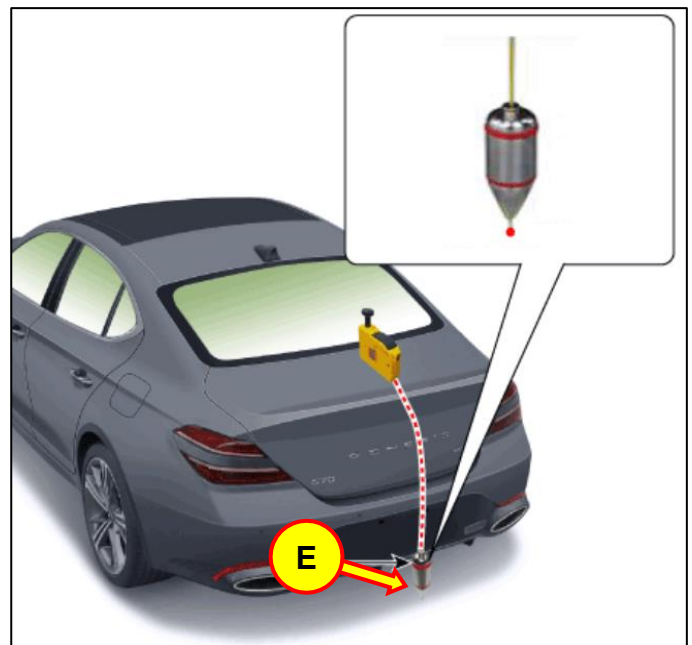

5. Pass the string under the bottom of the vehicle and fix the string using tape so it crosses the front center point of the vehicle (F).

Fix the string to the point (H), using tape, about **1.5 – 2 m** from the back of the vehicle so that it intersects the rear center point (G).

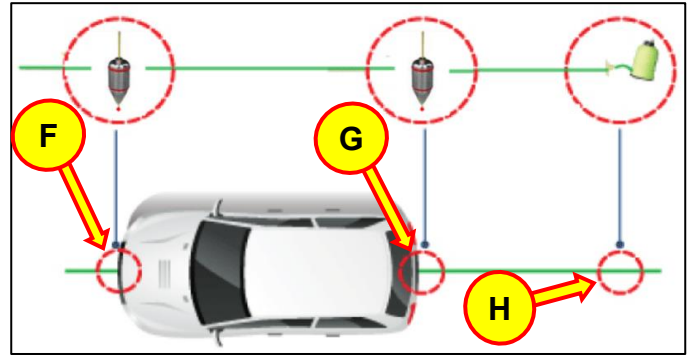

i Information

Do **NOT** to cover the center points marked on the ground during this step with mounting tape.

6. Mount the BCW Unit Fixing Adaptor SST to one of the rear corner radar units. Hook the adaptor to the top and bottom edges of the radar mount, then fasten the mounting hooks (I)(J).

i Information

BCW Unit Fixing Adaptor:

- SST 09958-3T080

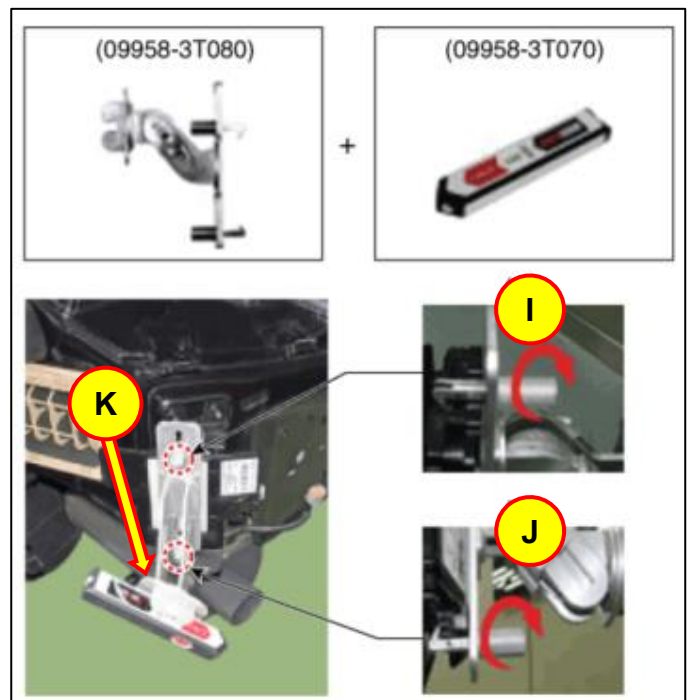

7. Fix the Laser Level SST (K) at an angle down and toward the centerline of the vehicle determined in the first portion by the green string, such that the laser beam intersects the string on the ground and creates an angle that can be measured. If mounted excessively horizontal, the beam will skip over the string. If too vertical, the laser will **NOT** reach the string.

i Information

Laser Level:

- SST 09958-3T070

8. Measure the angle (L) between the center line (M) and the laser level beam (N) using the Digital Protractor SST. Record the values for later use and be sure to indicate which radar was measured.

i Information

Horizontal Angle (C): $38^\circ \pm 2^\circ$

i Information

Digital Protractor:

- SST 09958-3T090

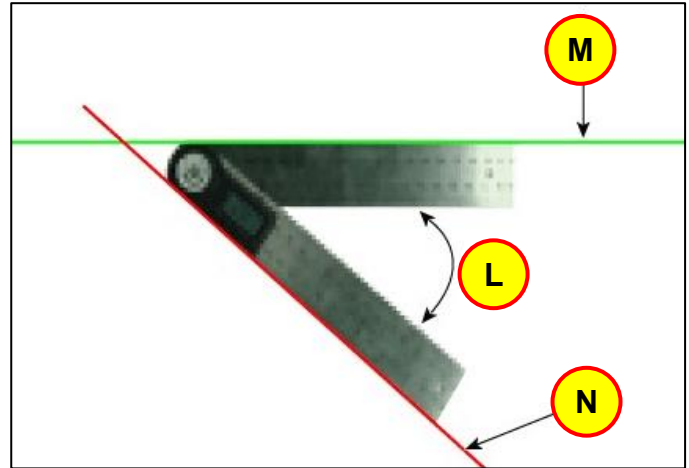

9. Use a Digital Inclinator SST to measure the vertical angle of the rear corner radar unit (O). Record the values for later use and be sure to indicate which radar was measured.

i Information

Vertical Angle: $90^\circ \pm 1^\circ$

i Information

Digital Inclinator:

- SST 09958-3T100



10. If the measured values deviate more than the allowed tolerance, insert a washer between the bracket of the rear corner radar unit (P) to get the angle within specification.

If adjustment using washers is needed, measure and record the values of the adjusted angles as described in **steps 8 and 9**.

i Information

Specified Values:

- Horizontal Angle: $38^\circ \pm 2^\circ$
- Vertical Angle: $90^\circ \pm 1^\circ$

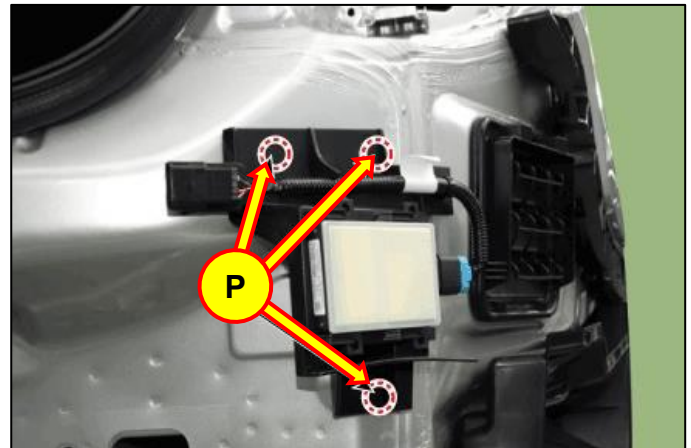

11. Perform **steps 6-10** again for the other rear corner radar unit.

Rear Corner Radar Calibration

1. Connect the VCI (II or III) to the data link connector in driver side crash pad lower panel and open the Genesis Smart application.
2. Select the vehicle model and **S/W Management (A)**.
3. Select **RR_C_RADAR R - Rear Corner Radar-Right (B)** and then **BCW(BSD) Radar Calibration (C)**.

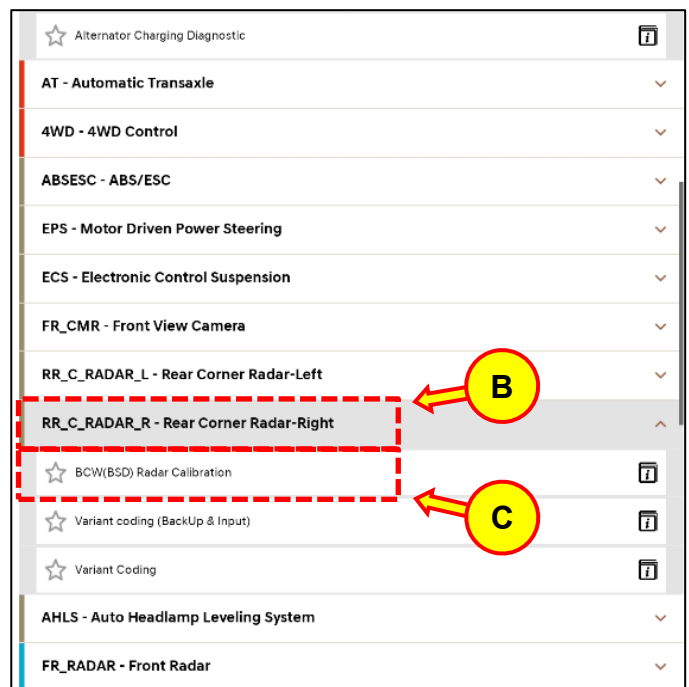
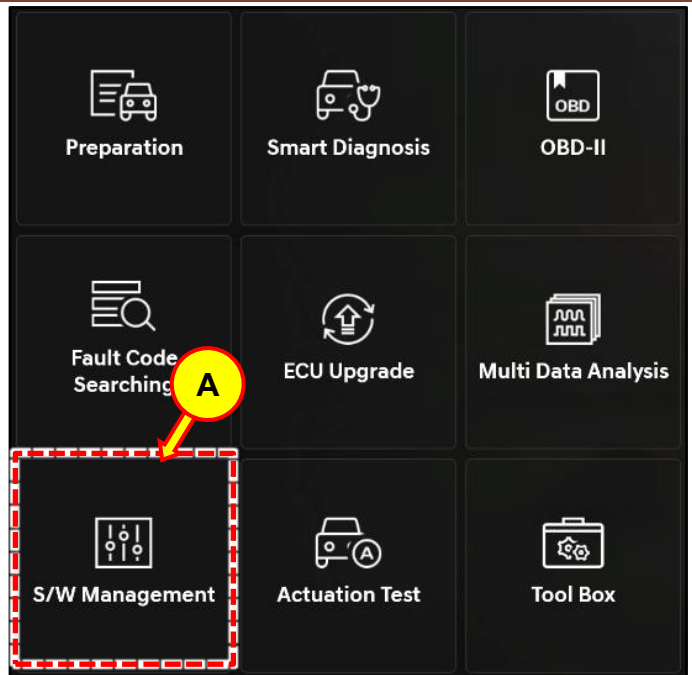

4. Check the purpose and enable conditions and select **Run** (D).

BSD Radar Calibration	
Purpose	To perform BSD sensor mounting angle measurement after a system fault or collision repair.
Enable Condition	1. Ignition On 2. Engine Off
Concerned Component	Blind Spot Detection(BSD) Radar
Concerned DTC	C2702XX, C2703XX
Fail Safe	Warning Lamp On
Etc	-



5. Check the condition and select **OK** (E).

*** [BCW(BSD) Radar Calibration]**

This function sets BSD Radar after replacement.

This calibration procedure will clear any 'Missing Calibration' DTCs which allows the Radar Sensors to go through the Self Alignment Procedure.

The Sensors continually self-align while the vehicle is driven.

[OK] button : Proceed with the function



6. Read the instructions and select **OK** (F).

*** [BCW(BSD) Radar Calibration]**

This function is used to compare vehicle BSD sensor mounting angles to specification.

Please install SST as shown below.

NOTE : Always follow the SST installation instructions.

[OK] button : Continue to proceed

[Cancel] button : End the function

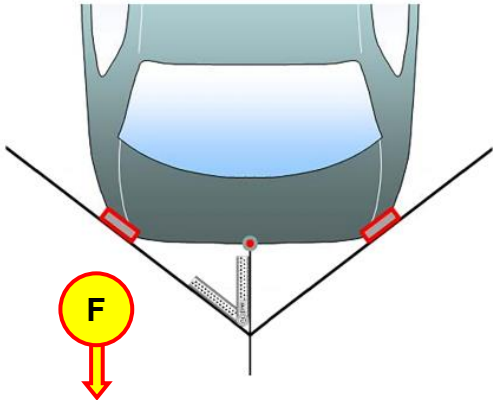

- Enter recorded horizontal angle values for the left and right radar units respectively from the procedure in boxes (G) and (H). Select **OK**.

i Information

Angle values were recorded in procedure **Rear Corner Radar Unit Angle Adjustment steps 8, 9, and 10** on page 16.

* [BCW(BSD) Radar Calibration]

Please enter the angles from your measurement.

[Warning]
If BSD angle is out of range, DTC C270254 or C270354 might occur.

[OK] button : Continue to proceed

Measured Angles	ϕ1(Left Side)	ϕ2(Right Side)

OK CANCEL

- Review the **Information** box:
 - If the values entered are within specification listed previously, select **OK** to proceed.
 - If the values are **NOT** within specification, adjust the angles using washers as shown in **Rear Corner Radar Unit Angle Adjustment, step 10** on page 16 until the radar is within specifications.
- When the calibration is complete, select **OK (I)**.

Information

The BCW(BSD) sensor angles are within specification.

[OK] Button : Continue to proceed

OK

Measured Angles	ϕ1(Left Side)	ϕ2(Right Side)
	38.0	37.3
Specification	38 ± 3.0	39 ± 3.0

Information

Turn ignition to OFF position, wait 5 seconds; then, turn ignition to ON position.

[OK] Button : Continue to proceed

OK

- Review the Radar Calibration message and select **OK** to exit.



Information

The vehicle must be driven for approximately an hour to fully calibrate the rear corner radar units.

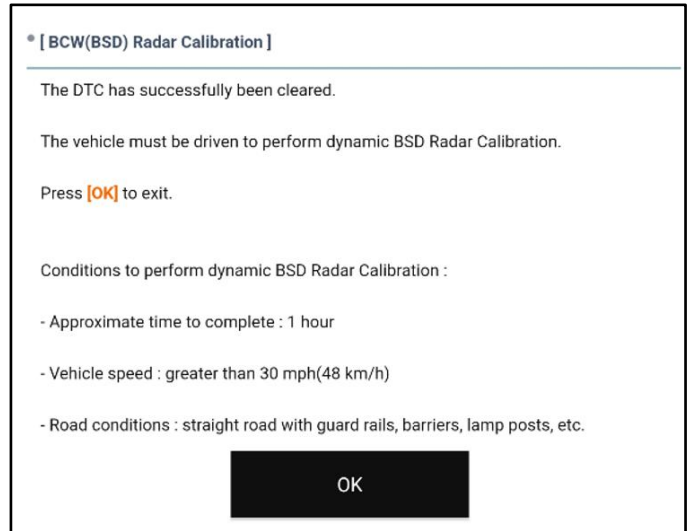

- Select **RR_C_RADAR_R - Rear Corner Radar-Right (J)** > **Variant Coding (K)**.

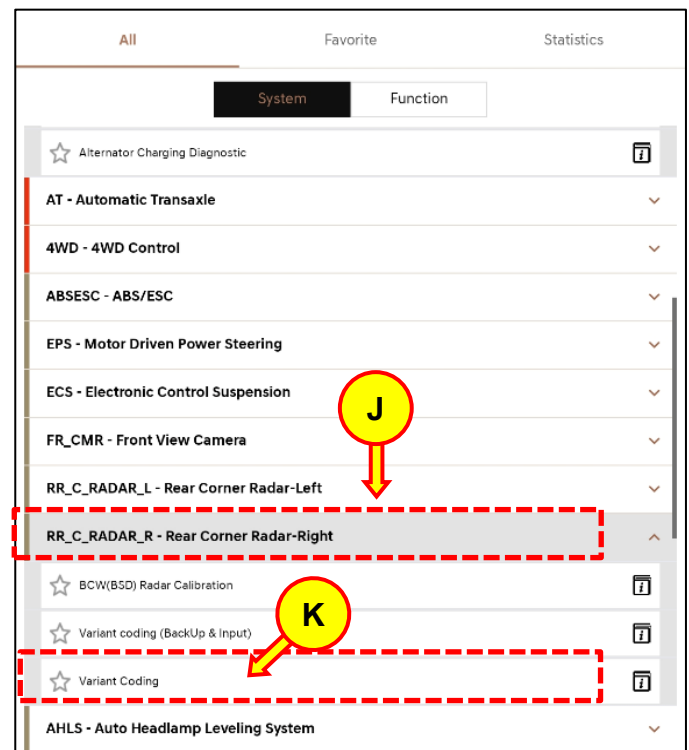

12. Check the purpose and enable conditions and select **Run** (L).

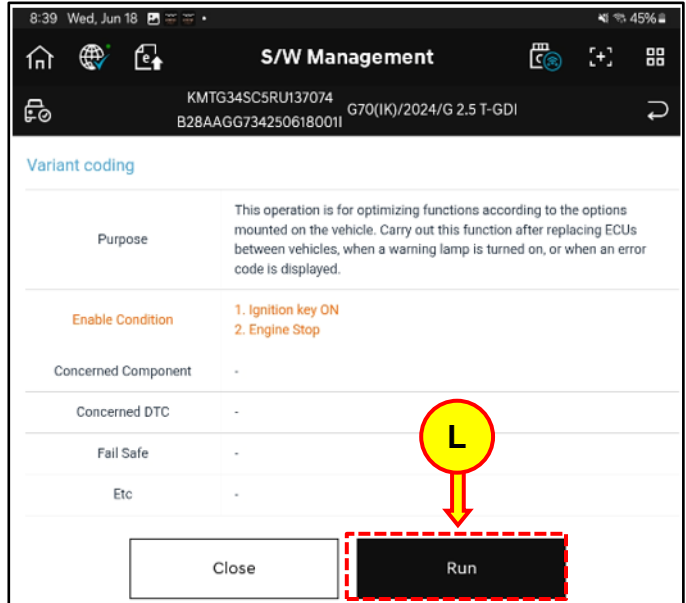

13. Check the condition and select **OK** (M).

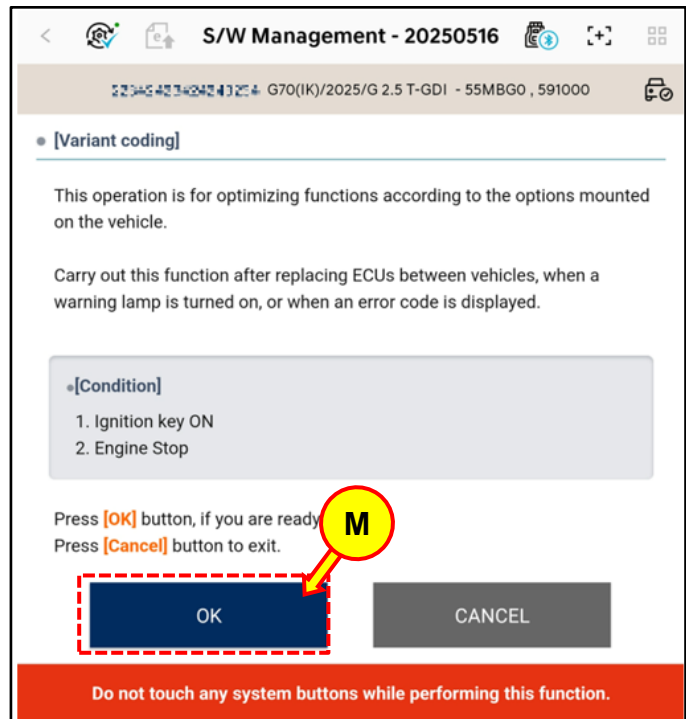

14. Select **MANUAL** (N).

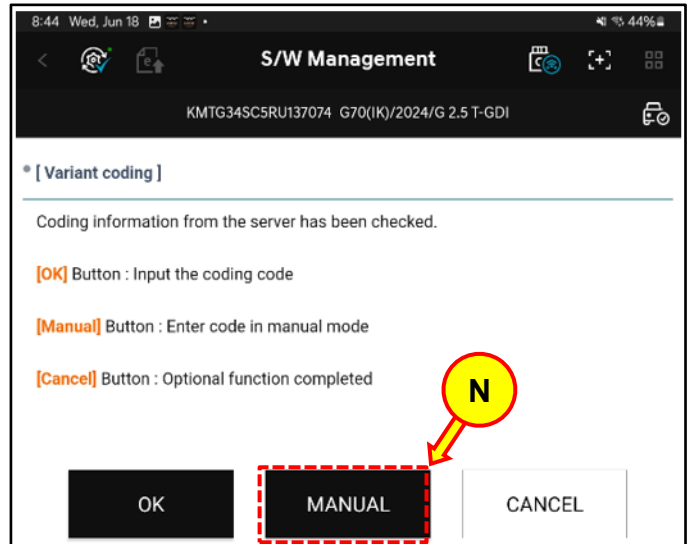

15. Input the variant coding recorded during the first procedure into **Entered coding value**.

i Information

Value is recorded in **Variant Coding Value Check, step 7** on page 6.

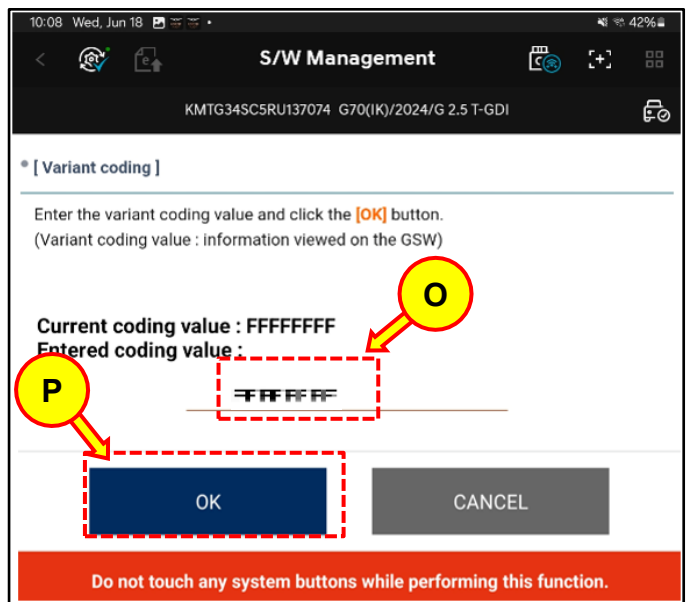

16. Select **OK** (Q). Turn the ignition off, wait **5** or more seconds, then turn the ignition back on.

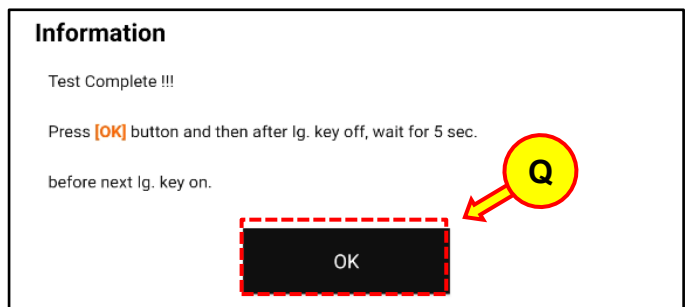

17. Repeat **steps 2–16** (calibration and variant coding) for **RR_C_RADAR_L – Rear Corner Radar – Left**.

18.

**DIGITAL
DOCUMENTATION**

Using STUI, take a photo of the new LH and RH Rear Corner Radar Units with the last 6 digits of the VIN, an L for the LH unit and an R for the RH unit, and the date of repair on a piece of paper.

Upload the photo to STUI.

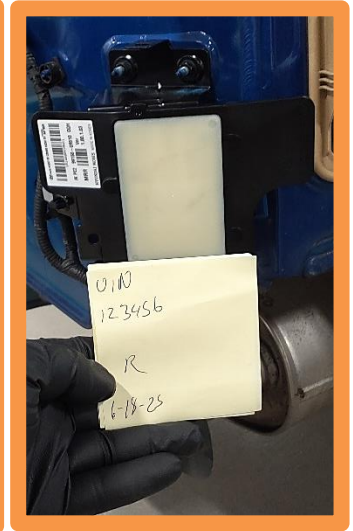
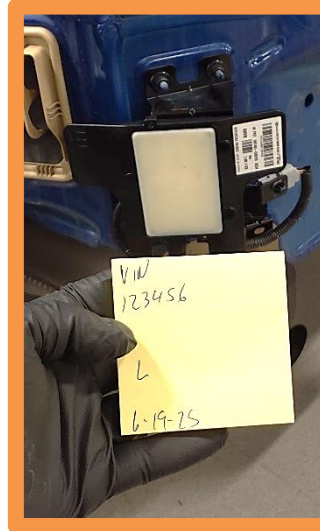

19. Refer to the procedure **Rear Bumper Removal** on **pages 8–11** and perform the steps in reverse to reinstall the bumper assembly.
20. The procedure is now complete.