



STAR ONLINE PUBLICATION



Case Number: S2523000066

Release Date: July 2025

Symptom/Vehicle Issue: Driver Side Window Switch Buttons Stuck Or Inoperative.

Customer Complaint/Technician Observation: Driver window/mirror adjust/ lock buttons are inoperative, stuck or switch button does not return to original position after pushed.

Discussion: Mis-install (excessive force on switch top surface) could cause misalignment of the buttons within the switch housing. The stuck button would be visible, and operating the button would not activate the function. Review the procedure below if this condition is present.

Repair Procedure:

- A. Use trim stick to remove the window switch assembly, disconnect the wiring connector. Refer to Service Library 08 - Electrical / 8N - Power Systems / Power Locks / SWITCH, Lock / Removal and Installation.
- B. Press the switch back plate assembly firmly to the bezel housing, and ensure all snap tabs are engaged. Press side walls to and visually confirm that all the snap tabs are inside the slots.
- C. Reconnect the wiring connector and snap fit the switch assembly into the armrest opening.

This document does not authorize warranty repairs. This communication documents a record of past experiences. STAR Online does not provide any conclusions about what is wrong with the vehicle. Rather, it captures all previous cases known that appear to be similar or related to the vehicle symptom / condition. You are the expert, and you are responsible for deciding on the appropriate course of action.

Contact STAR Center, or your Technical Assistance Center Via TechConnect, eCONTACT or Service Library entry if no solution is found.



STAR ONLINE PUBLICATION

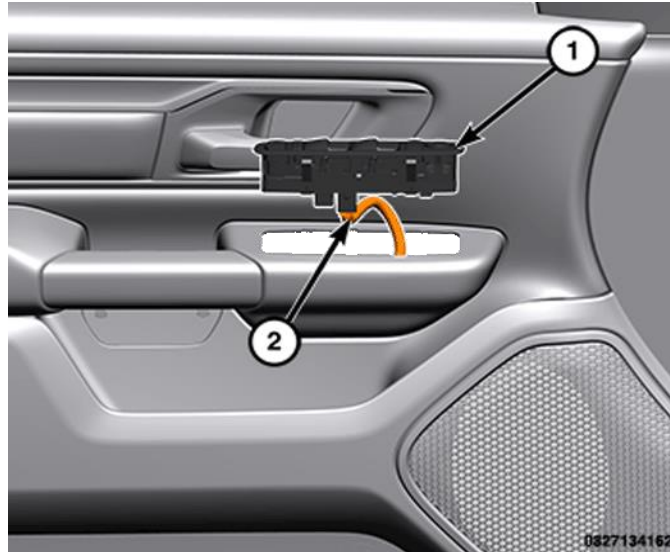

Removal of Lock Switch Assembly

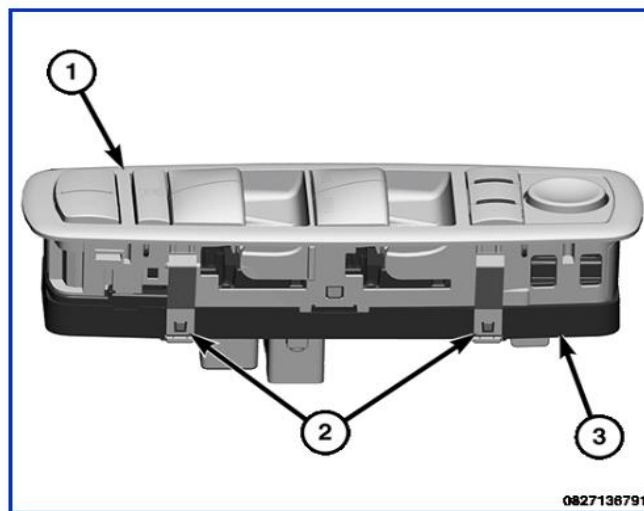

- 1 - Switch Bezel
- 2 - Switch Bezel Retaining Clips
- 3 - Switch Bank

This document does not authorize warranty repairs. This communication documents a record of past experiences. STAR Online does not provide any conclusions about what is wrong with the vehicle. Rather, it captures all previous cases known that appear to be similar or related to the vehicle symptom / condition. You are the expert, and you are responsible for deciding on the appropriate course of action.

Contact STAR Center, or your Technical Assistance Center Via TechConnect, eCONTACT or Service Library entry if no solution is found.