

TECHNICAL INSTRUCTIONS

FOR

SPECIAL SERVICE CAMPAIGN 25TC07

Blind Spot Monitor System Reprogramming

CERTAIN 2024 Model Year Tacoma and Tacoma HV

Updated

6.6.2025 – IX Step 3. Added Confirmation Step

5.20.2025 – VII Step 2. Cooling Fan Connector Image Updated

The repair quality of covered vehicles is extremely important to Toyota. All dealership technicians performing this recall are required to successfully complete the most current version of the E-Learning course “Safety Recall and Service Campaign Essentials”. To ensure that all vehicles have the repair performed correctly; technicians performing this recall repair are required to complete the following course:

- **TIC206A – Electrical Repair 1**

It is the dealership’s responsibility to select technicians with the above certification level or greater to perform this recall repair. Carefully review your resources, the technician skill level, and ability before assigning technicians to this repair. It is important to consider technician days off and vacation schedules to ensure there are properly trained technicians available to perform this repair at all times.

I. OPERATION FLOW CHART

The flow chart is for reference only. **DO NOT** use it in place of the full technical instructions. Follow **ALL** steps as outlined in the full technical instructions to confirm the campaign is completed correctly.

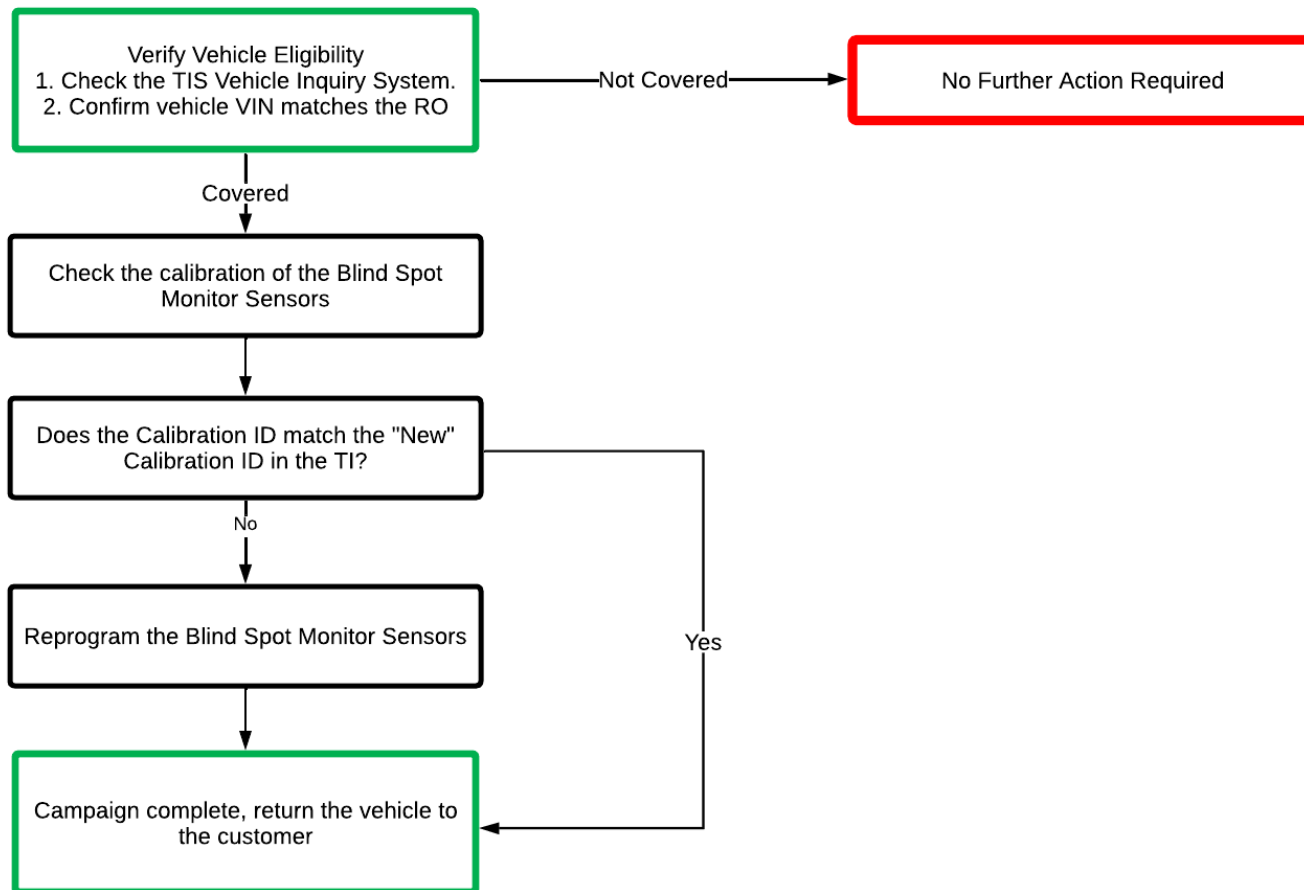

II. IDENTIFICATION OF AFFECTED VEHICLES

1. CHECK VEHICLE FOR CAMPAIGN ELIGIBILITY

- Compare the vehicle's VIN to the VIN listed on the Repair Order to ensure they match.
- Check the TIS Vehicle Inquiry System to confirm the VIN is involved in this recall, and that it has not already been completed.

NOTICE:

TMNA warranty will not reimburse dealers for repairs completed on vehicles that are not affected or were previously completed, even by another dealer.

III. PREPARATION

A. TOOLS & EQUIPMENT

- Standard Hand Tools
- T-SB-0021-25
- Techstream ADVi / Techstream 2.0 / Techstream Lite
- DCA-8000 Battery Diagnostic Station

IV. BACKGROUND

The subject vehicles are equipped with a Trailer Blind Spot Monitor (TBSM) system, which consists of two Blind Spot Monitor (BSM) sensors. Due to the programming of the BSM sensors, the TBSM system may not be able to detect the extended area for the trailer under certain operating conditions as described in the owner's manual.

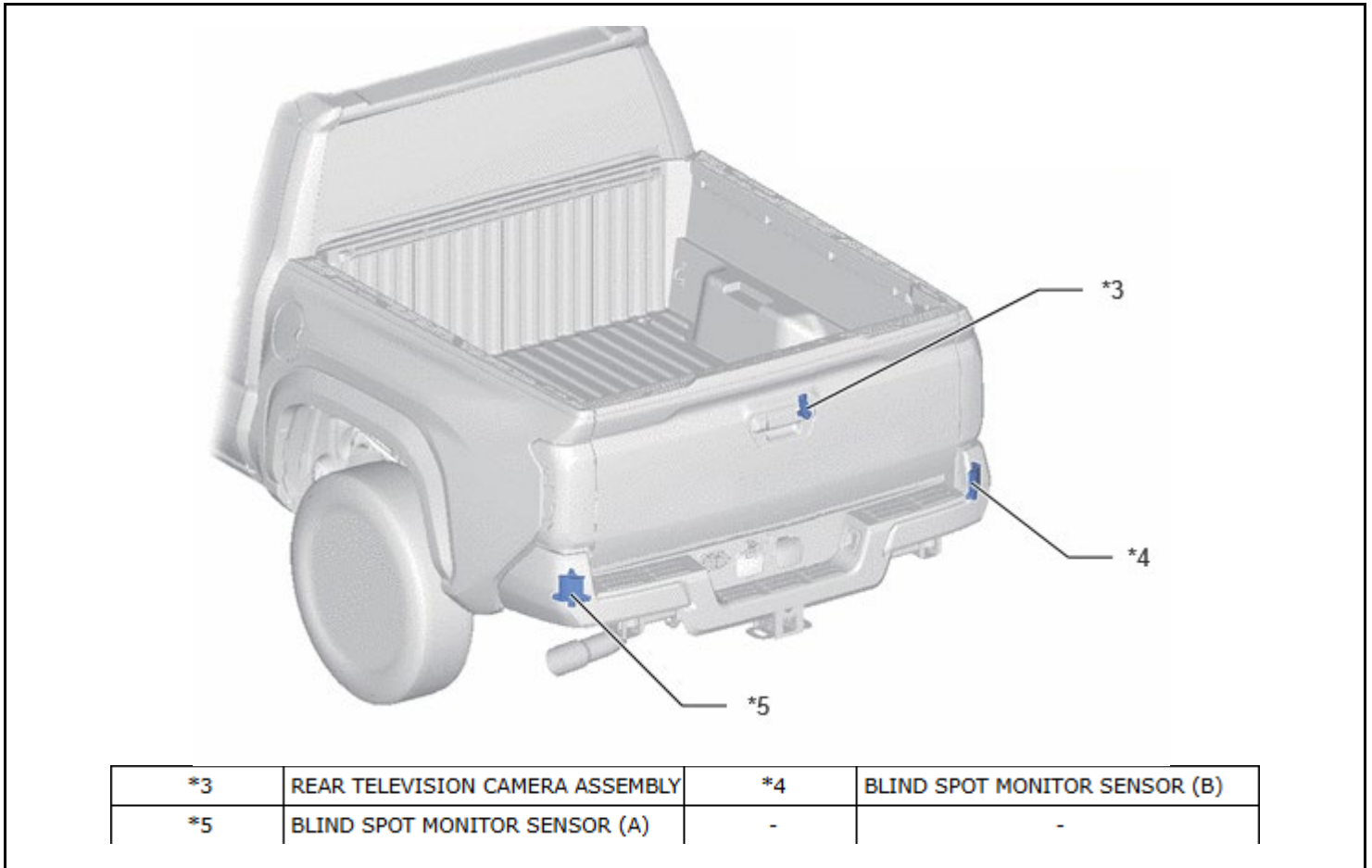

V. SAFETY PRECAUTIONS

Critical CRITICAL INFORMATION - READ THOROUGHLY

An ECU could be damaged if an error occurs in the communication while reprogramming the ECU. Confirm all work is performed as described in these instructions.

Be sure to connect the personal computer to an external AC power supply.

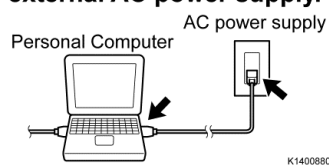

1. **STABILIZE THE POWER TO THE PERSONAL COMPUTER SIDE**
 - a. Be sure to connect the personal computer to an external AC power supply.

NOTICE:

The ECU could be damaged if the battery voltage of the personal computer drops while reprogramming.

Turn off the screen saver and power saving mode.



K140088008e

- b. Turn off the screen saver and power saving mode of the personal computer so that the power to the hard disk is kept supplied.

NOTICE:

If the screen saver or power saving mode launches while reprogramming, the communication may be disconnected, resulting in the damage of the ECU.

DO NOT block the ventilation opening.



K1400880068e

- c. **DO NOT** block the ventilation opening for the cooling fan of the personal computer.

NOTICE:

If the ventilation opening for the cooling fan is blocked with a sheet cover or the like, the personal computer may be heated excessively, causing the operation of the personal computer to stop. Due to the stop of the operation, the communication for reprogramming signals could be stopped, resulting in the damage of the ECU.

VI. Blind Spot Monitor CALIBRATION ID VERIFICATION



1. CHECK FOR DTC'S

- a. Using a Techstream, perform a Health Check to check for any Diagnostic Trouble Codes.

NOTICE:

This Campaign covers only the software update to the Blind Spot Monitor System, as detailed in these instructions. It does not cover the diagnosis or replacement of any other systems on the vehicle.

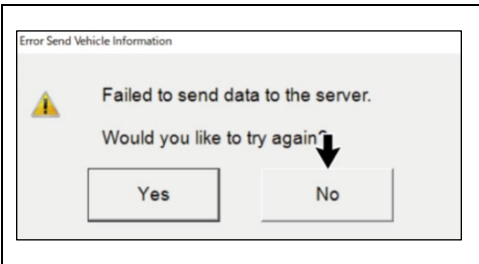

NOTE:

Before completing Health Check, "Send Vehicle Information" window may be displayed. If displayed, then click "Yes" to send the vehicle information.

- If "Failed to send data to the server" is displayed, click "No" to close the window and proceed to the next step.

2. CHECK CURRENT CALIBRATION

- a. Locate the Update column for the Blind Spot Monitor in the Stored Data tab for this vehicle.

The calibration IDs to re-flash in this campaign are as shown in the table below.

Blind Spot Monitor Sensor Calibrations			
Vehicle Model	System	Calibration ID	
		Current	NEW
TACOMA	Blind Spot Monitor "A"	8816FAK02202	8816FAK02302
TACOMA HYBRID	Blind Spot Monitor "B"	8816FAK02201	8816FAK02301

*Download file is the same for both Blind Spot Monitor "A" and "B"

2024 Tacoma HEV T24A-FTS | Production Date 04/09/2024 | 7508mile | Battery:11.5V

Health Check Result

STATUS

04/10/2025 08:52:05
 Campaign Status: **NONE**
 PERMANENT: NO
 ECU Security Key: -
 SOCE: - / SOCR: -

Tire Pressure / Threshold Value [psi(gauge)]
 Sensor1: N/A/27.68
 Sensor2: N/A/27.68
 Sensor3: 31.92/27.68
 Sensor4: N/A/27.68
 Sensor5: N/A/N/A

Compensation Pressure [psi(gauge)]
 Front:
 Rear:

GTS+ has established a Corporate network connection.
 A dealer connection is required to ensure all TIS functionality is available, such as campaign validation.

Caution

Completed: 04/10/2025 08:56:31

System	Monitor Status	Calibration Update	Update	Configure	RoB	DTC
Front Radar Sensor	-	8821F4801200	No	No	0	0
Blind Spot Monitor "B"	-	8816FAK02201	No	No	0	0
Blind Spot Monitor "A"	-	8816FAK02202	No	No	0	0
Acoustic Vehicle Alerting System	-	8657F3402001	No	No	-	0
Active Noise Control	-	8624F78020H0	No	No	-	0
Power Integration No.1	-	8A111AK03100	No	No	0	0
Power Distribution Box	-	8264FV20200A	No	No	0	0
Telematics	-	8273FAK0300A	No	No	0	0
Adaptive Variable Suspension System	-	N310nnBLBM0I	No	No	0	0
Stabilizer with Disconnection Mechanism	-	-	-	-	-	-

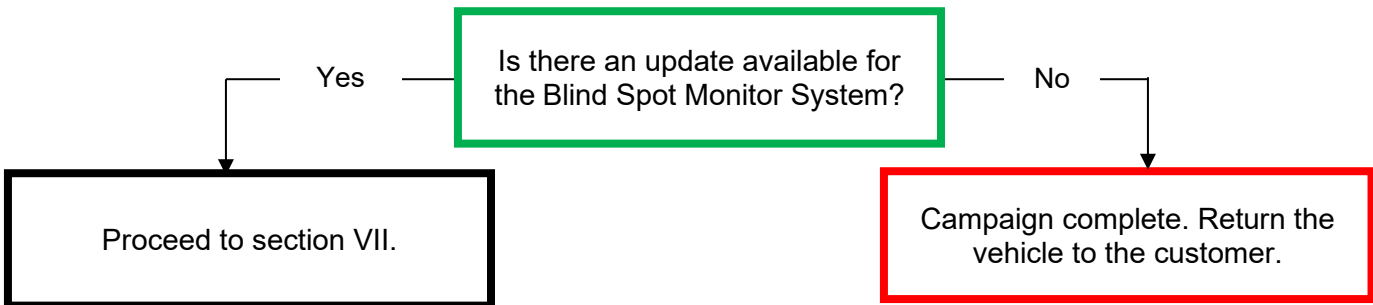

◀ CRITICAL MESSAGE ▶

It is critical that T-SB-0021-25 in addition to the Technical Instructions for this Safety Recall are followed. This TSB outlines all steps necessary to prevent reprogramming failure. Toyota will not provide reimbursement coverage for reprogramming failures if this TSB is not followed. If you have a reprogramming failure that requires Blind Spot Monitor ECU replacement and the Technical Instructions and TSB were followed correctly, please create a case with the Technical Assistance Hotline documenting all information related to the failure. If sufficient reporting is received related to re-flash failure, there will be consideration for reimbursement.

VII. VEHICLE PREPERATION

1. VEHICLE PREPARATION

a. Confirm the following conditions:

- Vehicle in the IG position (engine off).
- Transaxle in Park.
- Parking brake engaged.
- Turn off all electrical accessories (i.e. climate control, audio system, etc.)
- Headlight switch in the DRL OFF position.
- Windshield wiper switch in the OFF position.

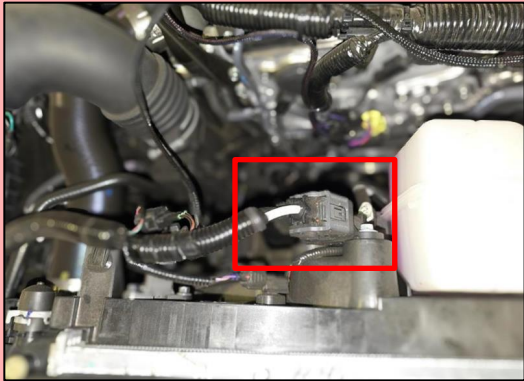

Front of Vehicle

2. DISCONNECT THE COOLING FAN MOTOR CONNECTOR.

Notice: • If you reprogram without disconnecting the cooling fan motor connector, the electric fan operates during reprogramming, causing a decrease of the battery voltage and the reprogramming processes will be disabled. This may result in damage of the ECU.

•After disconnecting the cooling fan motor connector, make sure that dirt, water or other foreign matter does not contact the cooling fan motor connector.

Critical

A power supply MUST be used during reprogramming. ECU damage will occur if the battery voltage is not properly maintained during this re-flash procedure.

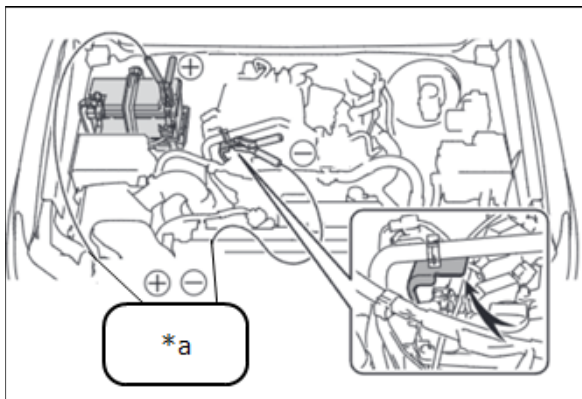

*a

Battery charger

3. CONNECT THE 12V BATTERY TO A POWER SUPPLY

- a) Connect the DCA-8000 or other type of power supply (not a battery charger) to the 12 V battery.
- b) Tap the Reflash icon from the Main Menu screen of the DCA-8000.

NOTICE:

A power supply must be connected directly to the 12V battery terminals and NOT the remote jump posts under the hood (if equipped).

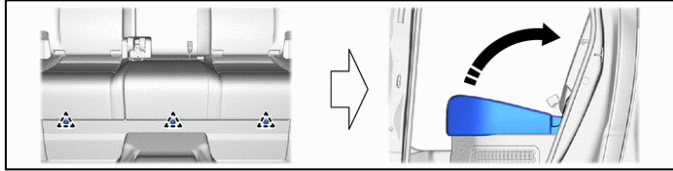

**For Hybrid Only:
ACCESS AUXILLARY BATTERY
Remove 3 PINS FROM FRONT OF THE SEAT**

- a) Remove 3 pins and lift seat up
- b) Connect the DCA-8000 or other type of power supply (not a battery charger) to the Auxiliary 12V battery.
- C) Tap the Reflash icon from the Main Menu screen of the DCA-8000.

4. VERIFY TECHSTREAM SETUP

- a. Verify that the Techstream meets the following conditions:
 - The latest version of software is loaded.
 - The Techstream battery is fully charged. If not, connect the Techstream to a 120 V source.
 - The DLCIII cable is in good condition.

Critical

The Techstream's battery voltage must also be maintained during the re-flash procedure. If necessary, plug the Techstream into a 120v outlet during this procedure.

NOTICE:

If the Techstream communication with the vehicle fails during the re-flash procedure, the ECU will be damaged.

VIII. UPDATE CALIBRATION



1. PERFORM VEHICLE HEALTH CHECK

2. CONFIRM THE ECU CALIBRATION ID

- a. Confirm the current calibration ID in the Blind Spot Monitor System.

System	Monitor Status	Calibration Update	Update	Configure	RoB	DTC
Front Radar Sensor	-	8821F4801200	No	No	0	0
Blind Spot Monitor "B"	-	8816FAK02201	No	No	0	0
Blind Spot Monitor "A"	-	8816FAK02202	No	No	0	0
Acoustic Vehicle Alerting System	-	8657F3402001	No	No	-	0
Active Noise Control	-	8624F78020H0	No	No	-	0
Power Integration No.1	-	8A111AK03100	No	No	0	0
Power Distribution Box	-	8264FV20200A	No	No	0	0
Telematics	-	8273FAK0300A	No	No	0	0
Adaptive Variable Suspension System	-	N310nnBLBM0I	No	No	0	0
Stabilizer with Disconnection Mechanism	-	-	-	-	-	-

The calibration IDs to re-flash in this campaign are as shown in the table below.

Blind Spot Monitor Sensor Calibrations			
Vehicle Model	System	Calibration ID	
		Current	NEW
TACOMA	Blind Spot Monitor "A"	8816FAK02202	8816FAK02302
TACOMA HYBRID	Blind Spot Monitor "B"	8816FAK02201	8816FAK02301

3. REFLASH THE BLIND SPOT MONITOR SYSTEM

- a. Click yes on the health check results screen or follow the links on the table above to begin the reflash process.

NOTICE:

Reflash failure should be extremely rare and can be avoided by following all instructions and reprogramming best practices.

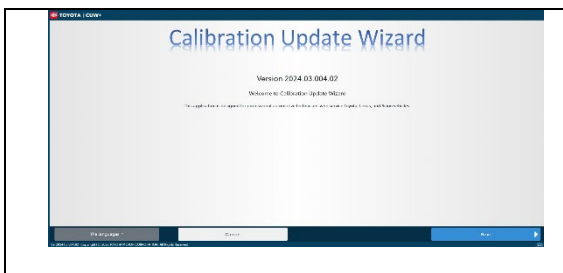

4. LAUNCH CALIBRATION WIZARD

- a. Select "Next"

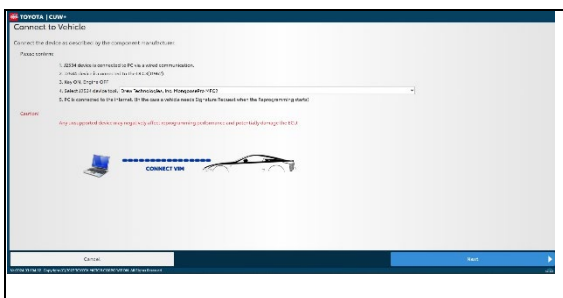

5. SELECT A DEVICE TOOL

- a. Select "Next"

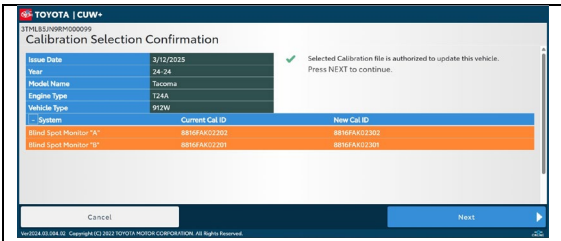

6. CONFIRM THAT "NEW CAL ID" IS CORRECT, AND THEN CLICK ON "NEXT".

Note: If the incorrect CAL ID file is selected it is not possible to move onto the re calibration.

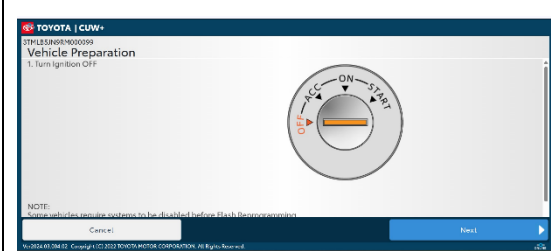

7. TURN THE IGNITION OFF, THEN CLICK "NEXT"

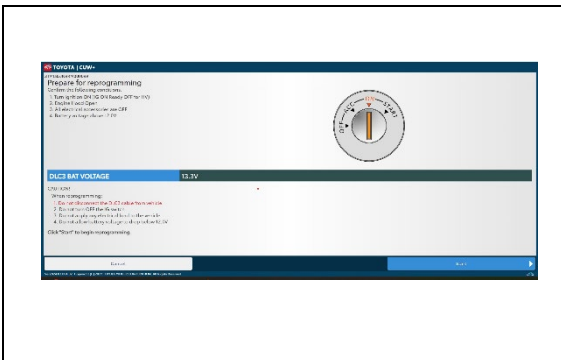
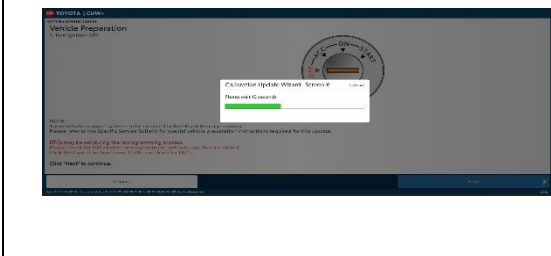

8. FOLLOW THE ON-SCREEN INSTRUCTIONS AND CONFIRM THE FOLLOWING, THEN CLICK "NEXT"

- a. PC is connected to VIM.
- b. Ignition is ON and engine is OFF
- c. Do not apply an electrical load to the vehicle.
- d. Battery voltage is above 12.0V

Notice for Hybrid Models: DO NOT turn the IG ON with the brake pedal depressed.

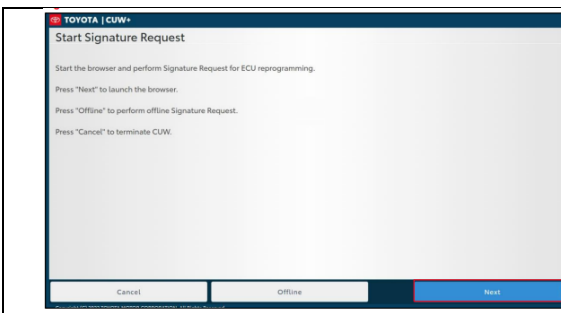

9. PERFORM SECURITY SIGNATURE TO THE SERVER, THEN HIT "NEXT"

- a. Follow the instructions on screen

Hint: The reprogramming will not begin without the security signature.



10. LOGIN TO TIS

- a. Input TIS login credentials and select "Login"

Note: This step requires internet.



11. PERFORM SECURITY SIGNATURE TO THE SERVER

- a. Input TIS login credentials and select "Login".



12. PERFORM SECURITY SIGNATURE TO THE SERVER

- a. Select "Send"



13. COPY SIGNATURE FROM TIS

- b. Select "Copy to Clipboard"

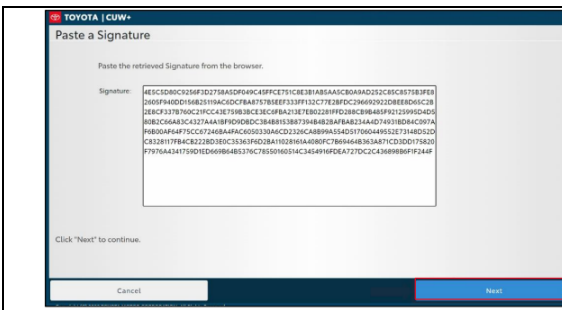

14. PASTE SIGNATURE INTO TECHSTREAM, THEN SELECT "NEXT"

15. RECALIBRATION WILL NOW BEGIN

- a. **Do Not** disturb the vehicle during flash reprogramming.

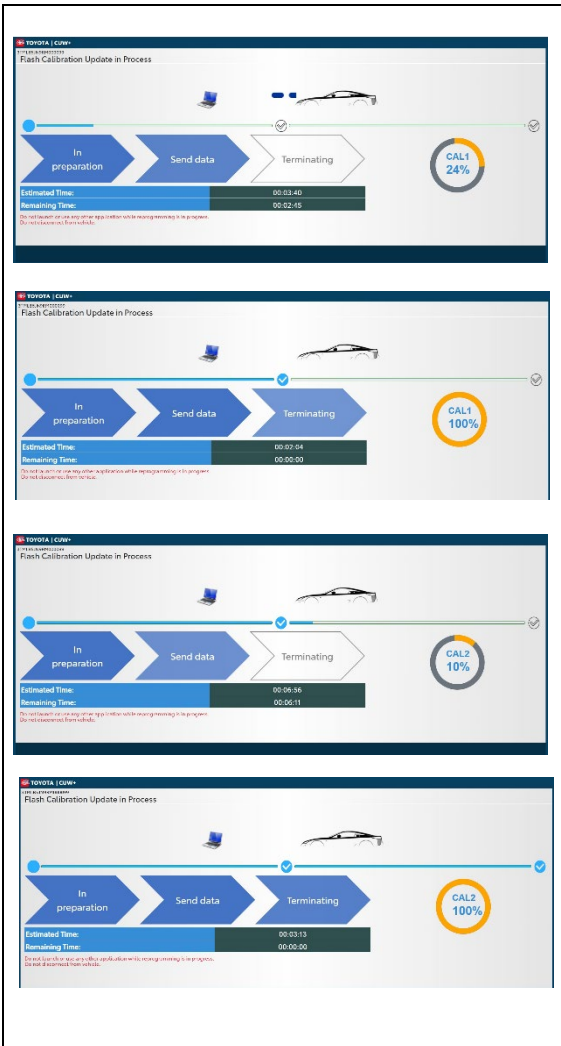

16. RECALIBRATION FINISHED

- a. The following Screens will appear at the end of the reflash.

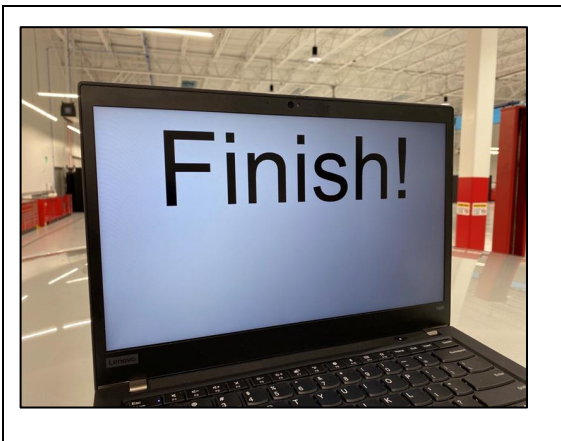

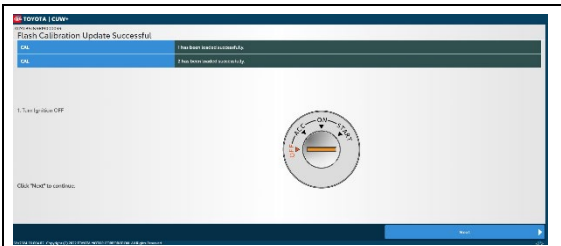

17. TURN THE IGNITION OFF FOR A MINIMUM OF 10 SECONDS, THEN CLICK “NEXT”

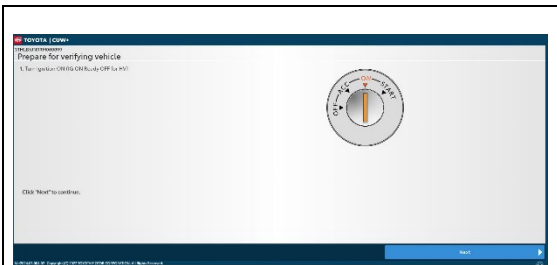
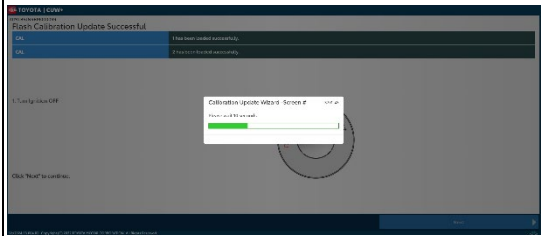

18. TURN THE IGNITION TO THE ON POSITION, THEN CLICK “NEXT”

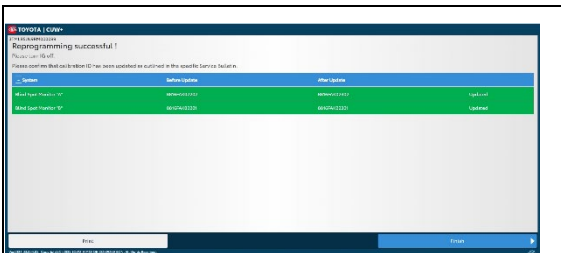

19. CONFIRM CALIBRATIONS WERE SUCCESSFULLY UPDATED THEN CLICK “FINISH”

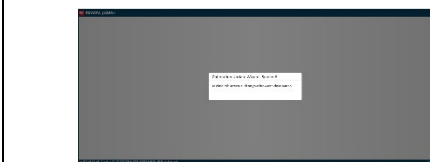

IX. COMPLETE REPAIR

1. DISCONNECT THE DCA-8000



2. PERFORM VERIFICATION HEALTH CHECK

- Using a Techstream, perform a Health Check.
- Clear DTC's that may have set during the re-flash procedure.
- Re-run the Health Check to confirm that no DTC's reappear.



THIS VERIFICATION HEALTH CHECK IS NECESSARY to update the results and CID's to the National database.

3. CONFIRM THE CONDITION IS NO LONGER PRESENT

- The Trailer Driving Assist Active message will either
 - No longer be displayed.
- OR
 - Need to be cleared by selecting **YES** on the "No Trailer Detected" pop up message after moving forward at a speed greater than 6 mph (10 km/h) for at least 10 seconds.

4. COMPLETE HEALTH CHECK AND CONFIRM CID UPDATE

- On the Stored Data tab, confirm the following for the Blind Spot Monitor System:
 - The Calibration number has the "**New CID**" number.
 - The Update column lists "**No**"

TOYOTA | GTS+ | ONLINE Region: NA

2024 Tacoma HEV T24A-FTS Production Date 04/09/2024 | 7508mile Battery:11.5V

Health Check Result

STATUS

04/10/2025 08:52:05 Campaign Status: **NONE** Tire Pressure / Threshold Value [psi(gauge)] Compensation Pressure [psi(gauge)]

PERMANENT: NO Sensor1:N/A/27.68 Front: GTS+ has established a Corporate network connection. A dealer connection is required to ensure all TIS functionality is available, such as campaign validation.

ECU Security Key: - Sensor2:N/A/27.68 Rear:

SOCE: - / SOCR: - Sensor3:31.92/27.68

Sensor4:N/A/27.68

Sensor5:N/A/N/A

Caution

Enhanced Generic Completed: 04/10/2025 08:56:31

System	Monitor Status	Calibration Update	Update	Configure	RoB	DTC
Front Radar Sensor	-	8821F4801200	No	No	0	0
Blind Spot Monitor "B"	-	8816FAK02301	No	No	0	0
Blind Spot Monitor "A"	-	8816FAK02302	No	No	0	0
Acoustic Vehicle Alerting System	-	8657F3402001	No	No	-	0
Active Noise Control	-	8624F78020H0	No	No	-	0
Power Integration No.1	-	8A111AK03100	No	No	-	0
Power Distribution Box	-	8264FV20200A	No	No	0	0
Telematics	-	8273FAK0300A	No	No	0	0
Adaptive Variable Suspension System	-	N310nnBLBM0I	No	No	0	0
Stabilizer with Disconnection Mechanism	-	-	-	-	-	-

Ver2024.03.004.02 Subscription Expiration:365d

5. CONFIRM THE COOLING FAN HAS BEEN RECONNECTED



Confirm the CID's has been updated successfully to the NEW CID's by someone other than the individual who performed the repair.

- Confirm Customer Health Check Report information is correct.
- Print Customer Health Check Report from TIS.
- Sign and provide to the customer.

◀ VERIFY REPAIR QUALITY ▶

- Confirm the Blind Spot Monitor ECU Calibration has been updated successfully to the NEW CID.
- Confirm the Cooling Fan has been reconnected
- Confirm there are no DTC's after the Calibration update.
- Confirm the condition is no longer present
- If you have any questions regarding this Campaign, please contact your regional representative

X. APPENDIX

A. CAMPAIGN DESIGNATION DECODER

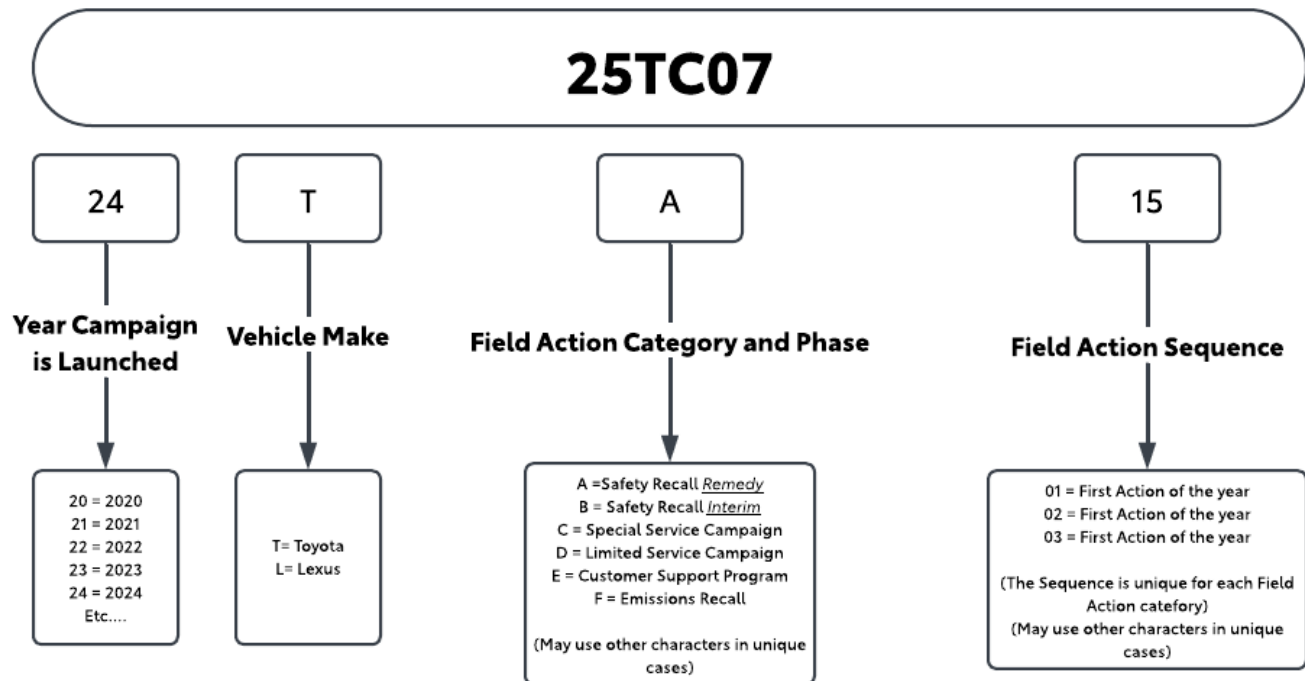

Examples:

19TA01 = Launched in 2019, Toyota, Safety Recall Remedy Phase, 1st Safety Recall Launched in 2019

20TC02 = Launched in 2020, Special Service Campaign, 2nd Special Service Campaign Launched in 2020

21TE05 = Launched in 2021, Customer Support Program, 5th Customer Support Program Launched in 2021