

# V O L V O

## Volvo Car USA LLC

## Technical Journal

Technical Journal Title CEL with DTC ECM P001100, P001200, P001400, P001500		Ref. No. TJ 37148.8.0	
Issuer (Dept.) Technical Service		Issue Date 5/28/25	Status Date 6/18/25
Car Market United States and Canada	Partner 3 US 7510 Volvo Car USA	Function Group 2154	
Function Description Camshaft		Page Page 1 of 69	

### Attachment

File Name	File Size
TJI-531608-1_1_1_en-US 1.pdf	3.6338 MB
TJ_37148_1.pdf	0.0566 MB
<a href="#">TJ_37148_3.mp4</a>	3.6388 MB

Rows beginning with \* are modified

Note! If using a printed copy of this Technical Journal, first check for the latest online version.

### DESCRIPTION:

\**Vehicle type updated.*

\* *Additional/modified information under Service*

If there is a "Check Engine Light" lit in DIM and one or a combination of the listed DTCs below are set, please follow advice under "service".

DIM: Driver Information Module.

ECM: Engine Control Module.

### CSC Customer Symptom Codes

Code	Description
DL	Warning lights and chimes/Malfunction Indicator Light ("Check engine" light) indication/no indication

### DTC Diagnostic Trouble Codes

Control Module	Code	Fault Type
ECM	P001100	Permanent
ECM	P001200	Permanent
ECM	P001400	Permanent
ECM	P001500	Permanent

## Technical Journal 37148.8.0

---

### Vehicle Type

Type	Eng	Eng Desc	Sales	Body	Gear	Steer	Model Year	Plant	Chassis range	Struc Week Range
224	L1	BL1KERS					2022-9999		-	202122-999952
227	L1	BL1KERS					2023-9999		-	202222-999952
236	06	B06KERS					2022-9999		-	202122-999952
238	06	B06KERS					2022-9999		-	202122-999952
246	06	B06KERS					2022-9999		-	202122-999952
246	L1	BL1KERS					2022-9999		-	202122-999952
246	M1	BM1KERS					2025-9999		-	202417-999952
256	06	B06KERS					2023-9999		-	202222-999952
256	L1	BL1KERS					2023-9999		-	202222-999952
256	M1	BM1KERS					2025-9999		-	202417-999952
536	K9	BK9KERS					2023-2023		-	202222-202321
536	L1	BL1KERS					2023-9999		-	202222-999952

### SERVICE:

\*For **MY 23-26 vehicles with engine code L1**, an improved software is released in version 3.5.14 (and newer). Perform a Total Upgrade according to TJ 31543 before performing additional VIDA symptom-based fault tracing.

- Software for remaining models will be released later in calendar year 2025

\*If VIDA symptom-based fault tracing leads to the replacement of parts, follow the method in attachment TJI-531608-1\_1\_1\_en-US 1.pdf.

**Observe - only hand tools should be used according to VIDA methods, otherwise parts can be damaged.**

\*If VIDA symptom-based fault tracing leads to the replacement of parts, retain the material according to the regular procedure as described in Warranty Policy and Procedure Manual (WPPM)

\*If the camshafts are replaced or the cylinder head is disassembled, the sealing rings must *always* be replaced.

\*The camshaft should be replaced if the sleeve is axially locked. Compare with the attached files:

OK: TJ\_37148\_1.MOV

NOK: TJ\_37148\_2.MOV

\*If a vehicle comes in for a repeat repair with the same DTC with the latest software as described above, and the intake camshaft has not been replaced previously, then replace the intake camshaft.

Wear on the outside of the camshaft is not a reason to replace the part. Compare with the attached file [TJ\\_37148\\_1.pdf](#).

If the VVT pulley seems loose or has free play, it is not a reason to replace the part. Compare with the attached file [TJ 37148 3.mp4](#).

### Warranty claim info:

To get a warranty claim accepted for a job described in this TJ, use the corresponding VST OP number stated in this TJ.

Note that the TJ number must be stated in the repair order text.

### VST Operation Number

VST Operation Number	Description
36001-2	Diagnostic trouble codes read/ reset
36002-3	Software control module downloading
98783-2	Camshaft sleeve acc.to TJ.

### VEHICLE REPORT:

Yes, please submit a Vehicle Report according to the info under service. Use concern area "Vehicle Report" and sub concern area "Support needed", use function group 2154.

**To view TJ attachments continue to next page. This TJ has two attachments and one video file.**

TJ 37148

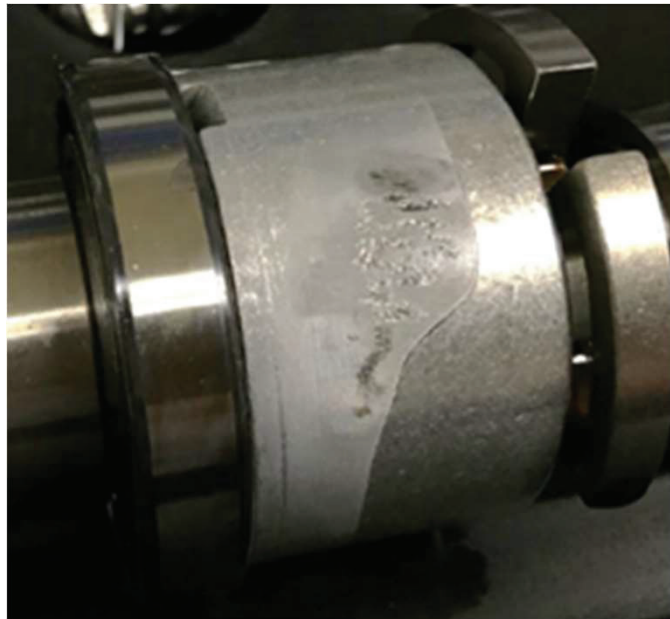



## Volvo Car Customer Service

TJ Instruction VCC-531608-1

<b>Title</b>	Camshaft bushing	<b>Page</b>	1 ( 65 )
<b>Action</b>	Replacement	<b>Operation number:</b>	98783-2

Issue	Date	Reason
1	2025-03	First issue

### Affected vehicles

Model year	Model	Engine
2021, 2022, 2023, 2024, 2025	S60 (19-)	B420T, T10, T2, T3, T4, T5, T6
2021, 2022, 2023, 2024	S90 (17-)	B420T, T10, T2, T6
2021, 2022, 2023, 2024, 2025	S90L	B420T, T2, T6
2021, 2022, 2023, 2024, 2025	V60 (19-)	B420T, T10, T2, T3, T4, T5, T6
2021, 2022, 2023, 2024, 2025	V60 Cross Country (19-)	B420T10, T2
2021, 2022, 2023, 2024, 2025	V90 Cross Country	B420T, T10, T2
2021, 2022, 2023, 2024, 2025	XC60 (18-)	B420T, T10, T2, T6
2021, 2022, 2023, 2024, 2025	XC90 (16-)	B420T, T10, T2

### Materials

Materials	Qty.	Part No.	Notes
Isopropanol	0.02		
Engine oil	0.02		
Chemical gasket	0.1	1161771	

### Special tools

Description	Part No.
RADIATOR PROTECTION	999 5474
Mounting	999 7534
Support	999 7533

**Special tools**

<b>Description</b>	<b>Part No.</b>
Counterhold	999 7718
Hook wrench	981 4129
L-hook	951 2943
Cleaning tool	999 7505

**Equipment**

<b>Designation</b>	<b>Part No.</b>
Interior trim remover	
Marker pen	
Screw M10 x 20 mm	
Putty knife (plastic)	
Abrasive cloth	

## Removal

**Note! Removal steps in this procedure may contain installation details.**

Illustrations in the information may be reused from previous models and may therefore deviate as regards the background's motif. The technical content relevant to the operation is, however, always correct.

## Color symbols

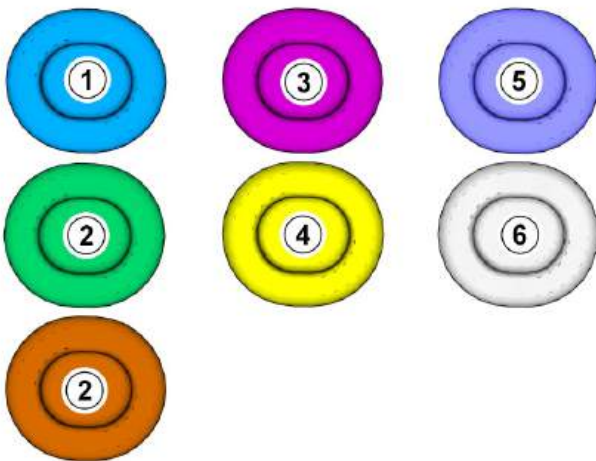

**Note! This colour chart displays (in colour print and electronic version) the importance of the different colours used in the images of the method steps.**

- 1 . Used for focused component, the component with which you will do something.
- 2 . Used as extra colors when you need to show or differentiate additional parts.
- 3 . Used for attachments that are to be removed/installed. May be screws, clips, connectors, etc.
- 4 . Used when the component is not fully removed from the vehicle but only hung to the side.
- 5 . Used for standard tools and special tools.
- 6 . Used as background color for vehicle components.

See information on safety information fuel system , refer to:

- General Safety Information
- 2 - Engine with mountings and equipment
- 23 - Fuel system
- 230 - general



**Note! Orientation view**

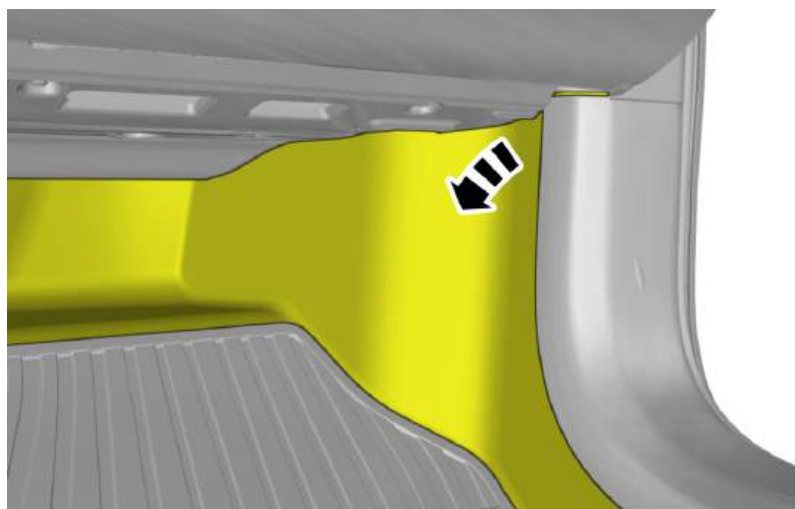

Fold the carpet aside.

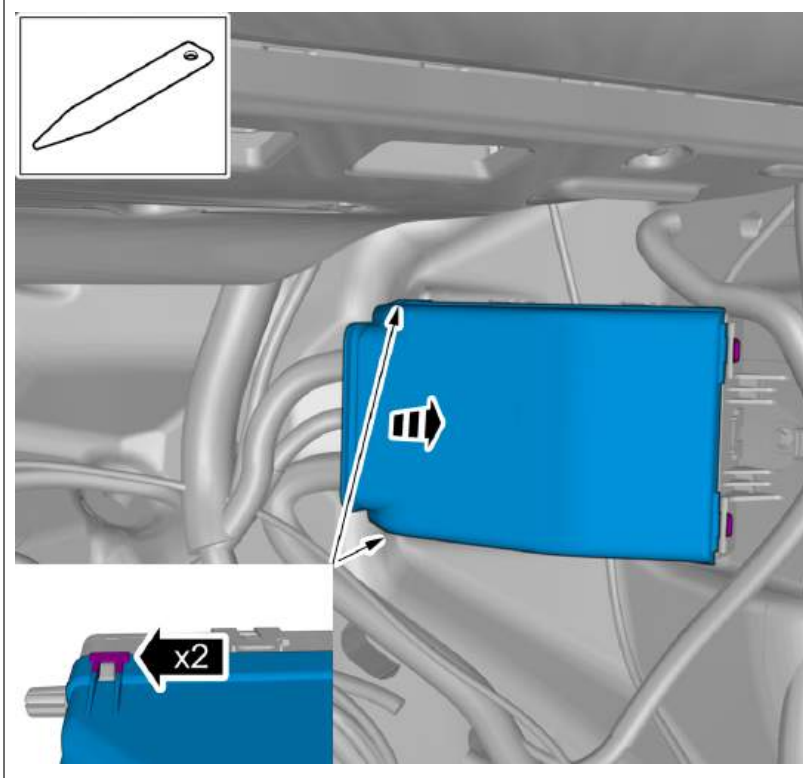

Remove the marked part.

**Use:** Interior trim remover

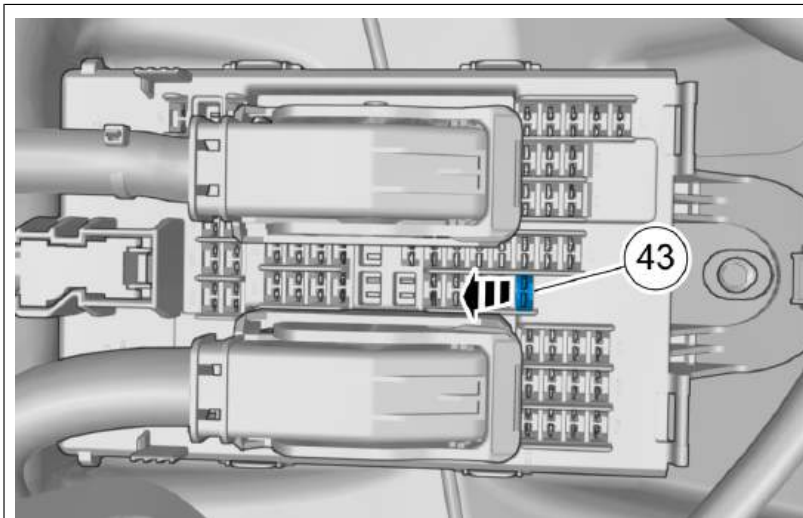

Remove the fuse for the fuel pump (FP).



Start and run the engine at idle until it stops.

### Disconnecting the battery

Disconnect mid voltage battery, disconnecting and connecting , refer to:

Cleaning, Inspection and Adjustment

3 - Electrical system

31 - Battery and mounting

311 - battery

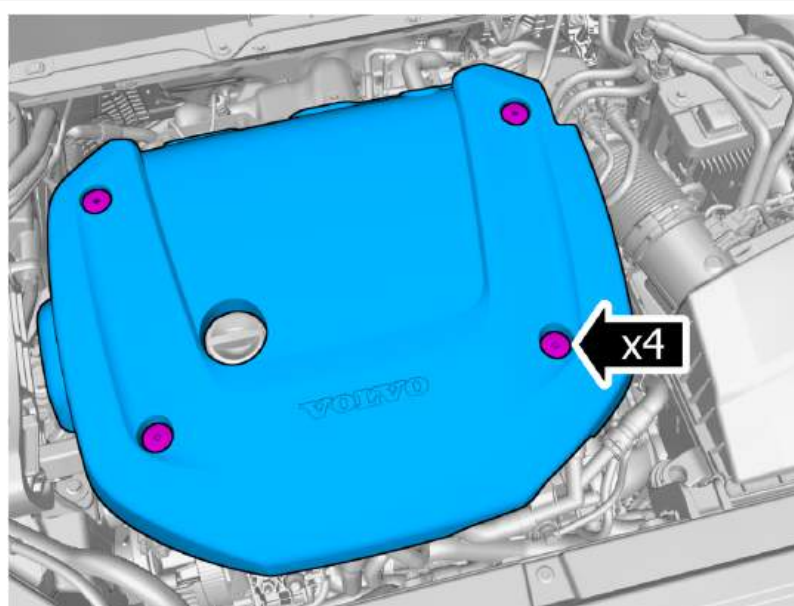

Loosen the screws.

Remove the marked part.

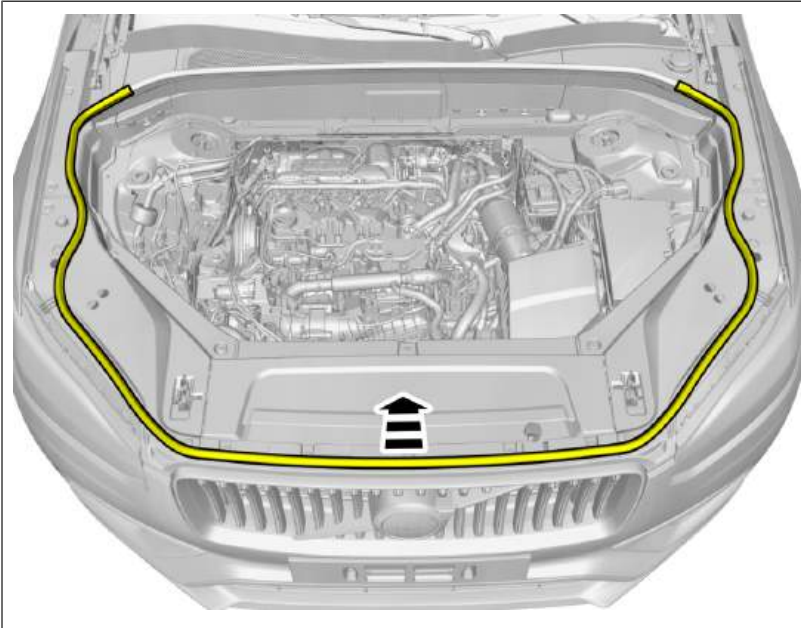

Fold marked part aside.

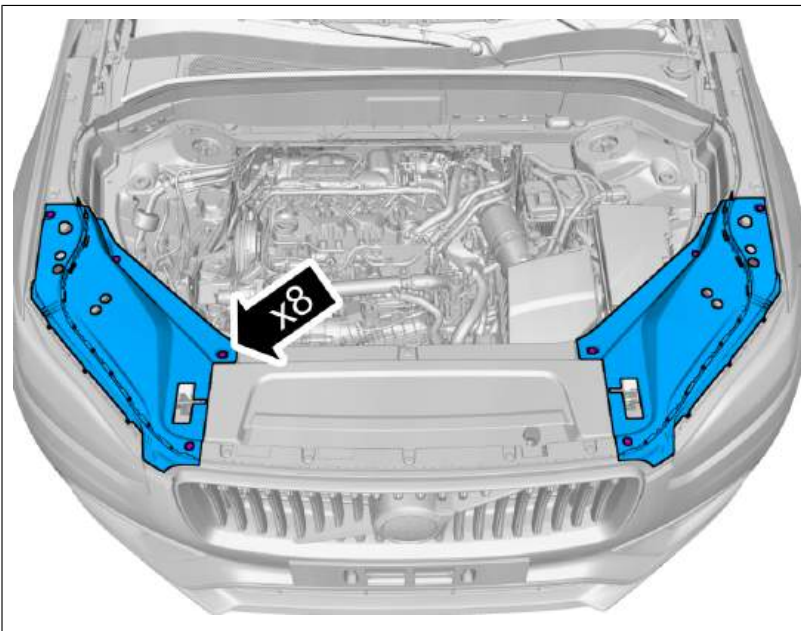

Remove the clips.  
Remove the marked parts.

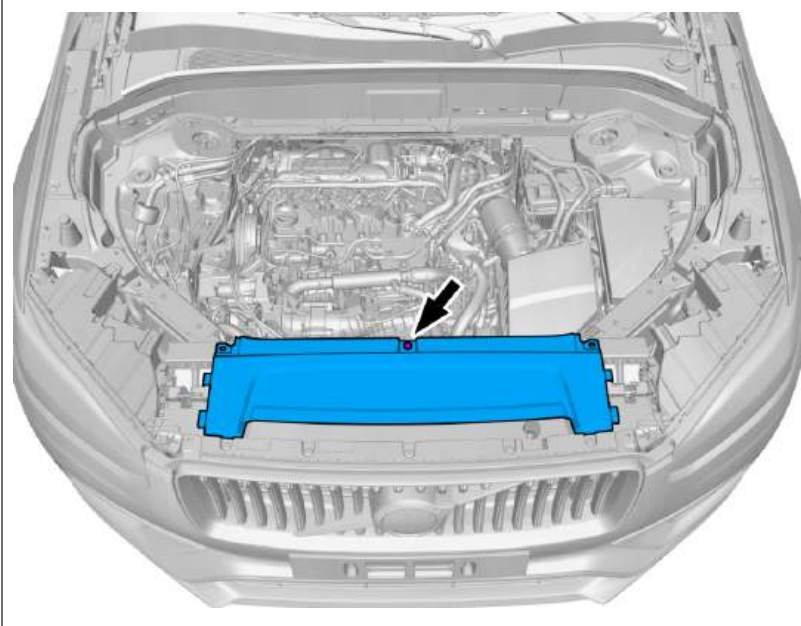

Remove the clip.  
Remove the marked part.

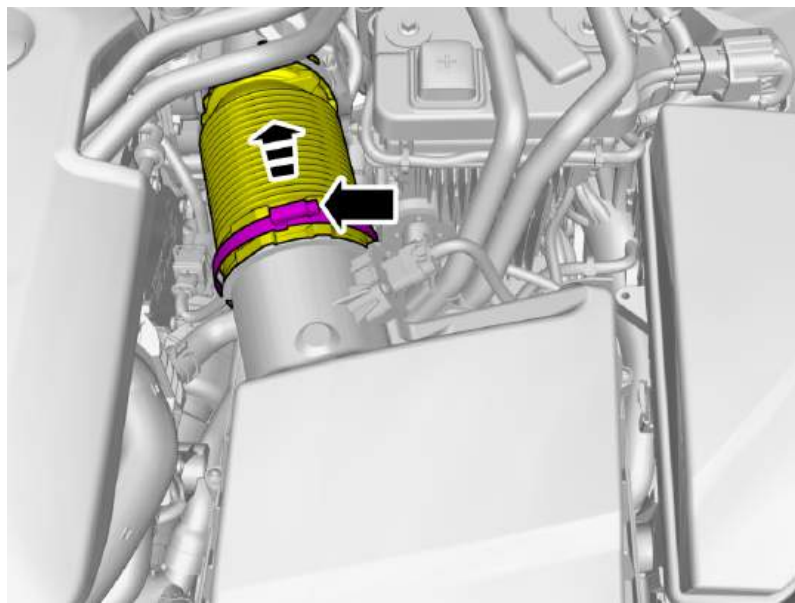

Loosen the hose clamp.  
Undo the hose from the connection.

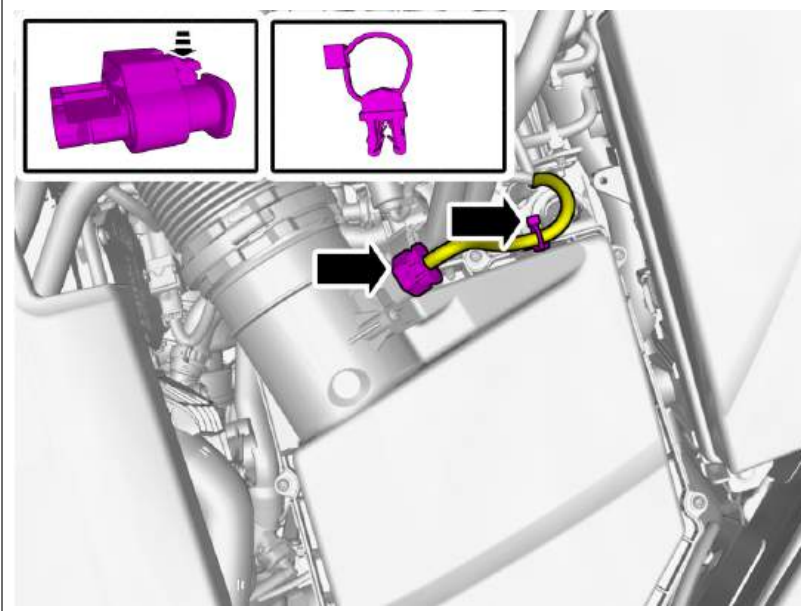

Disconnect the connector.  
Remove the cable harness clips.

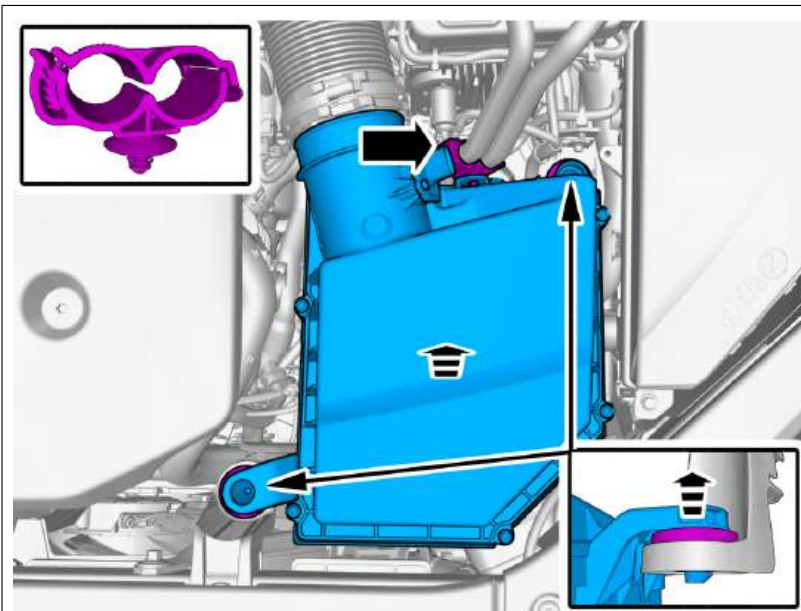

Loosen the clip.  
Lift the marked component up

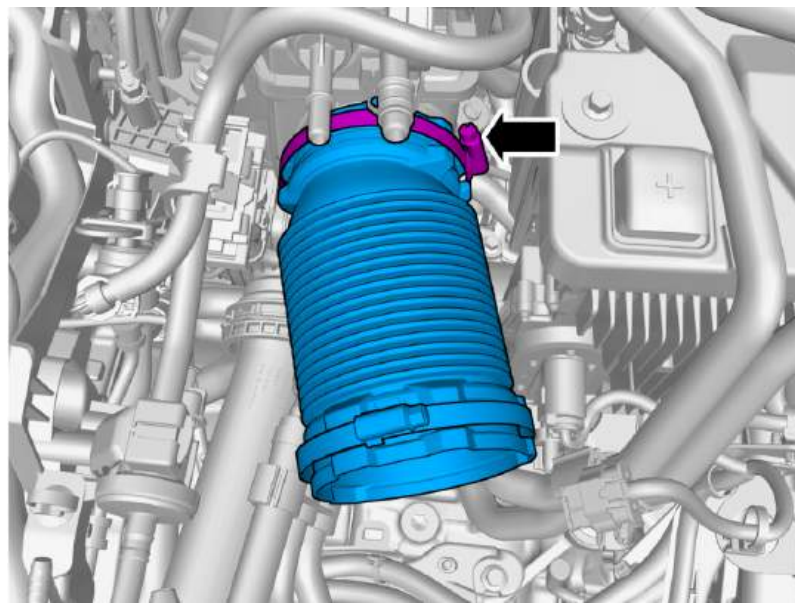

Loosen the hose clamp.  
Remove the marked part.

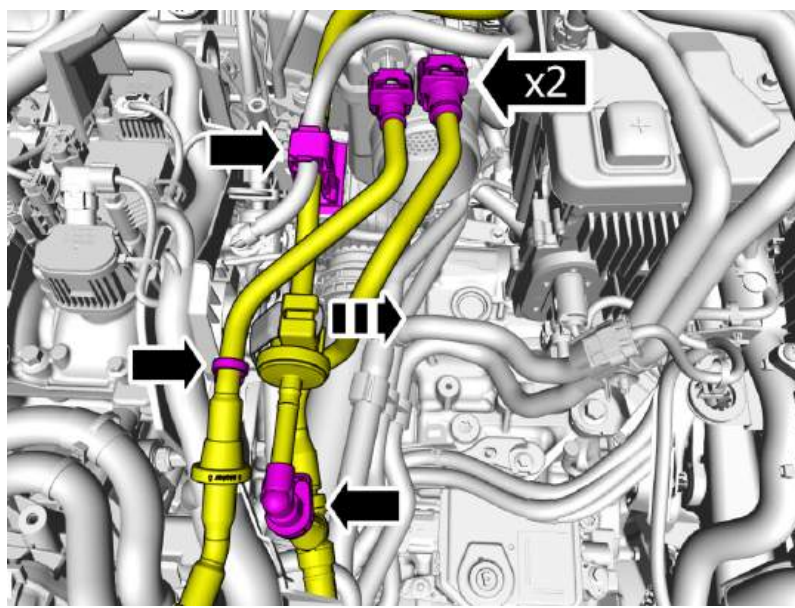

Remove the clips.  
Release the locks.  
Undo the hoses from the connections.  
Fold marked parts aside.

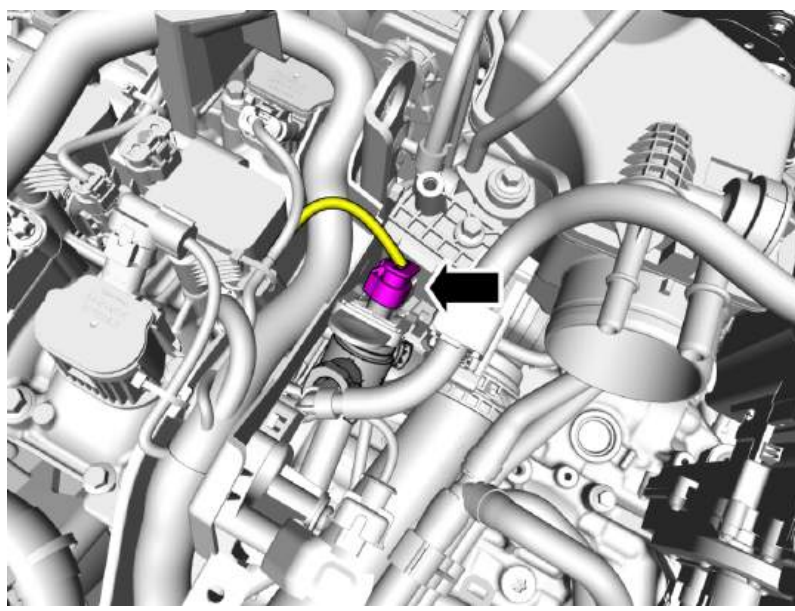

Disconnect the connector.

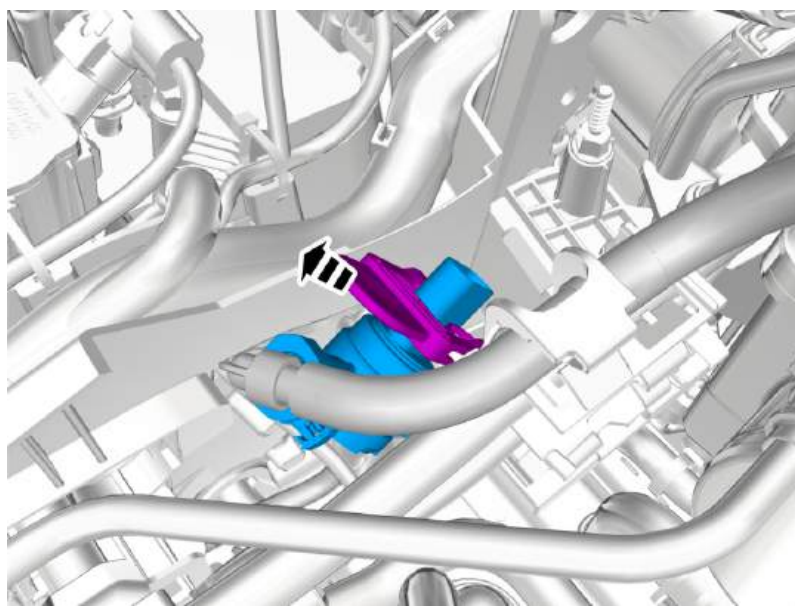

Loosen the clip.

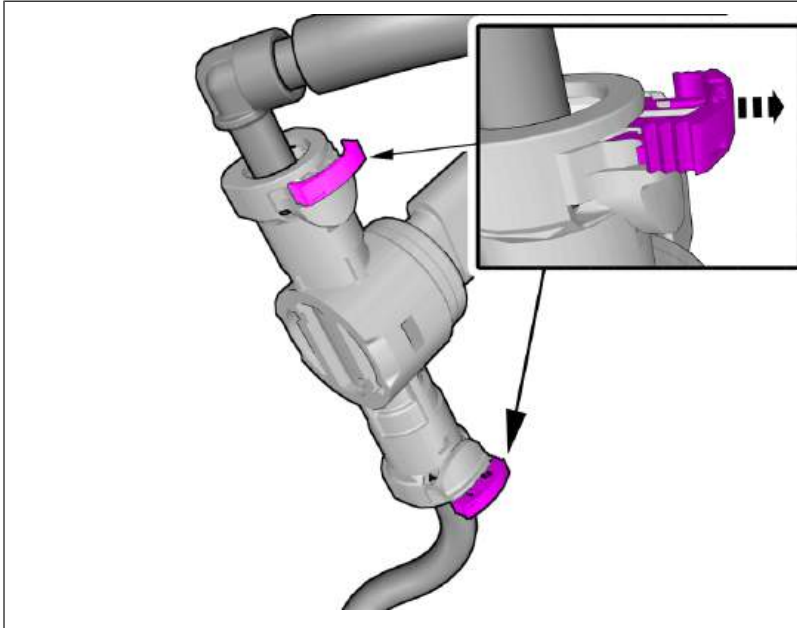

Release the locks.

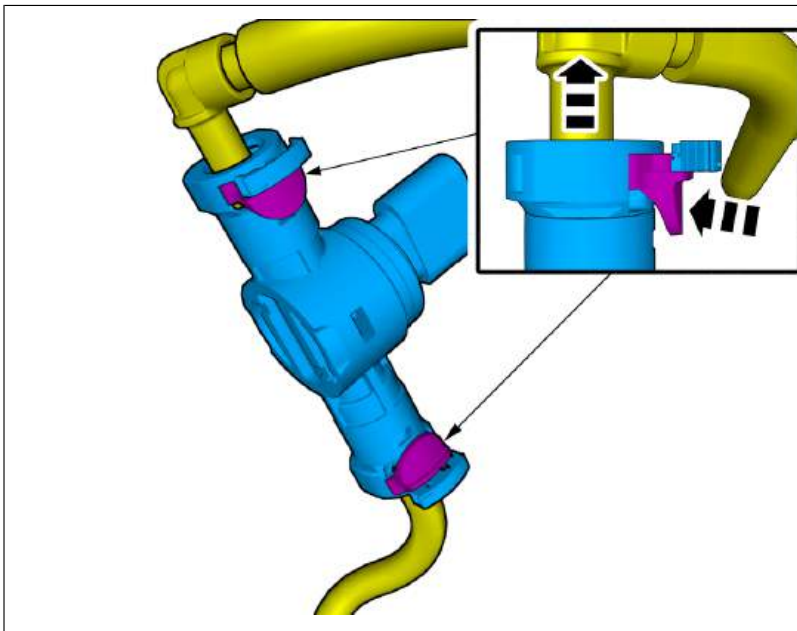

**Warning!** Be prepared to collect escaping fluid.

Depress the locking devices.  
Undo the hoses from the connections.  
Fold marked part aside.  
Remove the marked part.

## Extra information

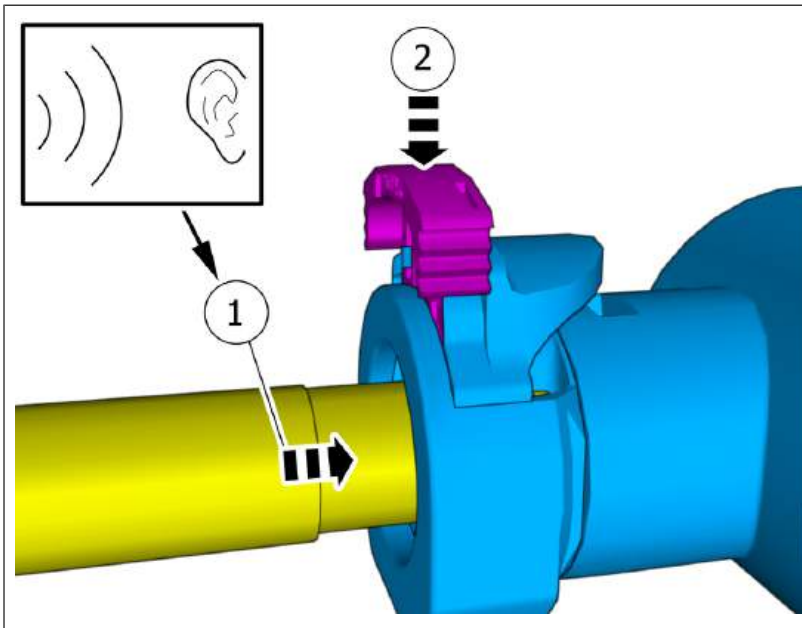

On both sides.

- 1 . Press until a click is heard.
- 2 . Depress the locking devices.

Continue the removal following the steps below.

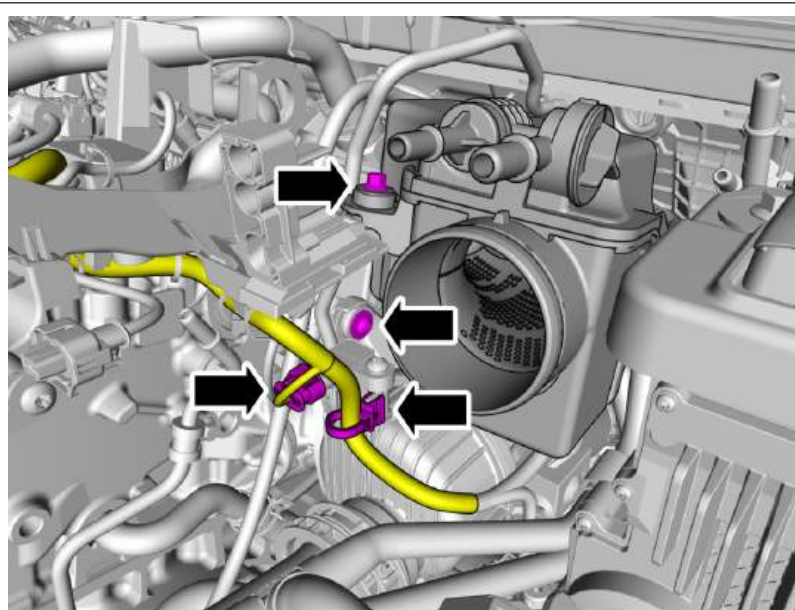

Remove the screws.  
Disconnect the connector.  
Loosen the clip.  
Fold the cable harness aside.

**Torque:**

M6 , 10 Nm

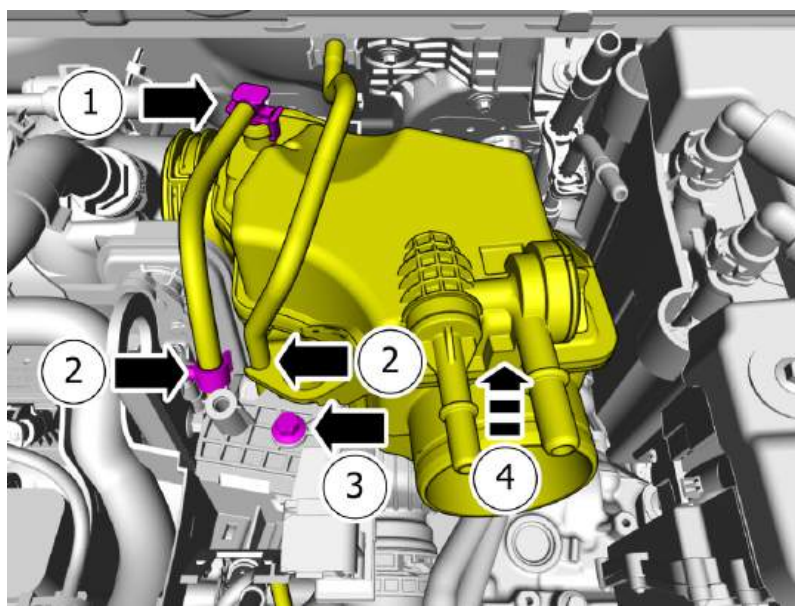

- 1 . Undo the hose from the connection.
- 2 . Loosen the marked details from the clip/ clips.
- 3 . Remove the screw.
- 4 . Turn in direction of arrow until stop.
- 5 . **Torque:**  
M6 , 10 Nm

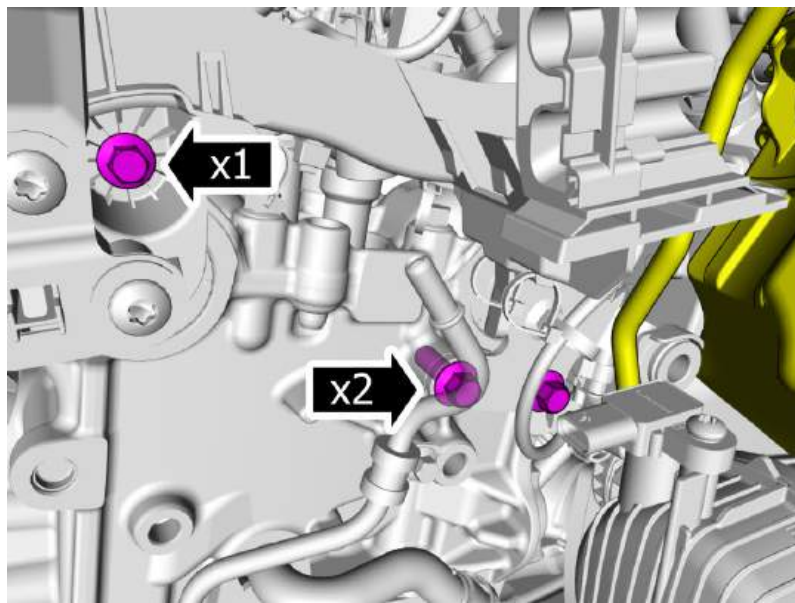

Remove the screws.

- 1 . **Torque:**  
M6 , 10 Nm
- 2 . **Torque:**  
M8 , 24 Nm

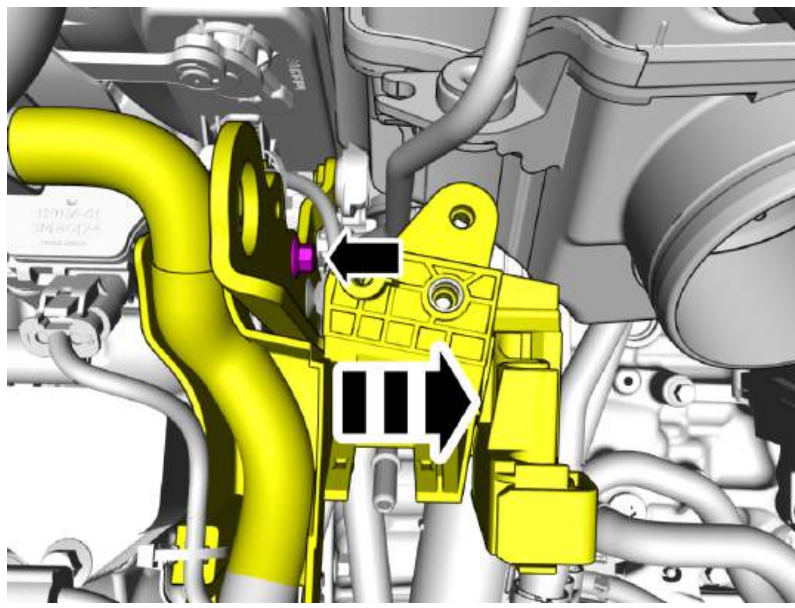

Fold marked parts aside.  
Remove the screw.

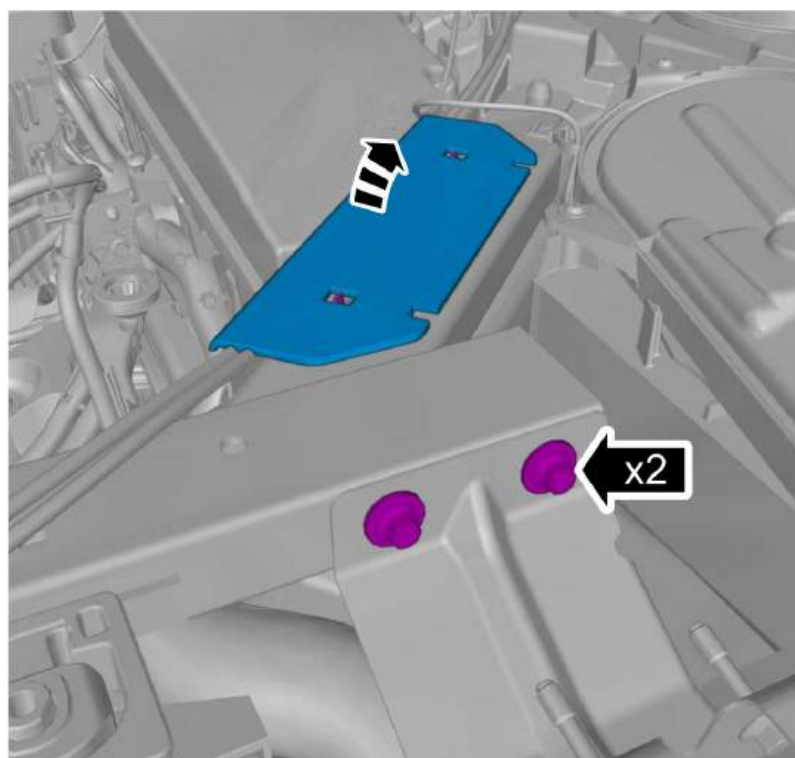

Remove the marked part.  
Remove the screws.  
On both sides.

**Torque:**

M6 , 10 Nm

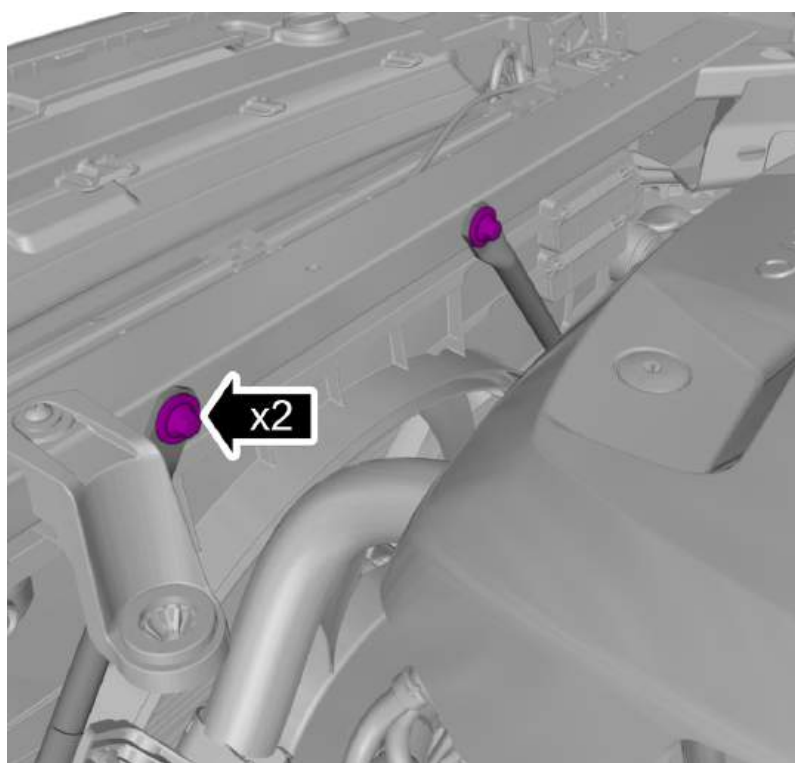

Remove the screws.

**Torque:**

M8 , 24 Nm

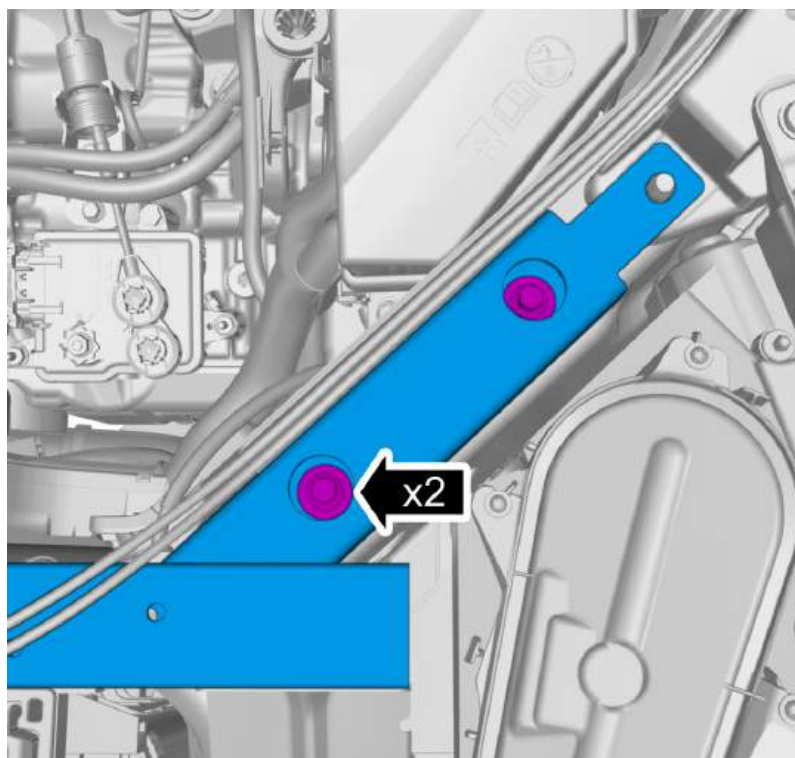

Remove the screws.

On both sides.

**Torque:**

Front end to upper side member , 30 Nm

Remove the marked part.

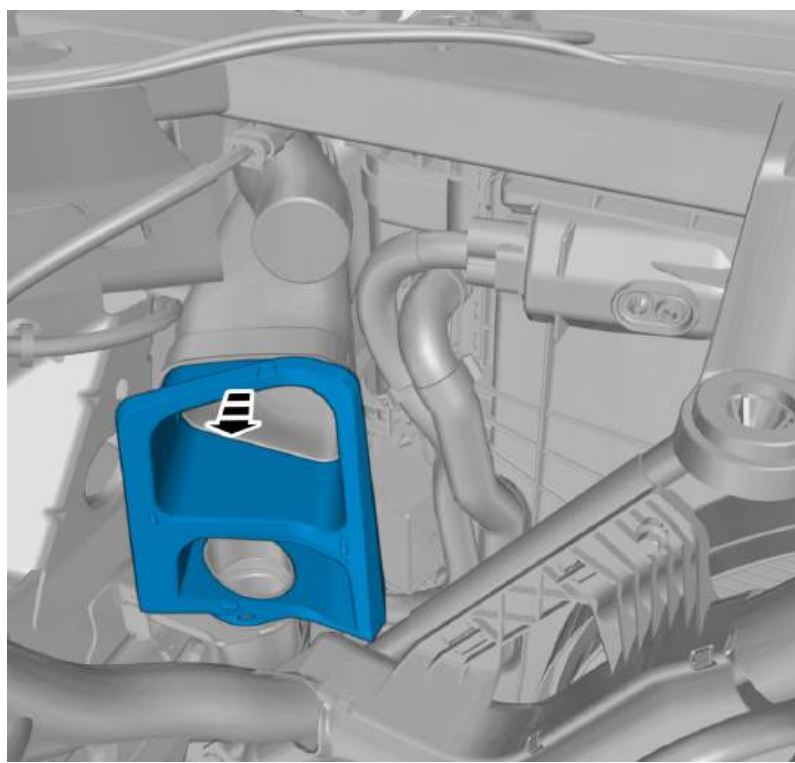

Remove the marked part.

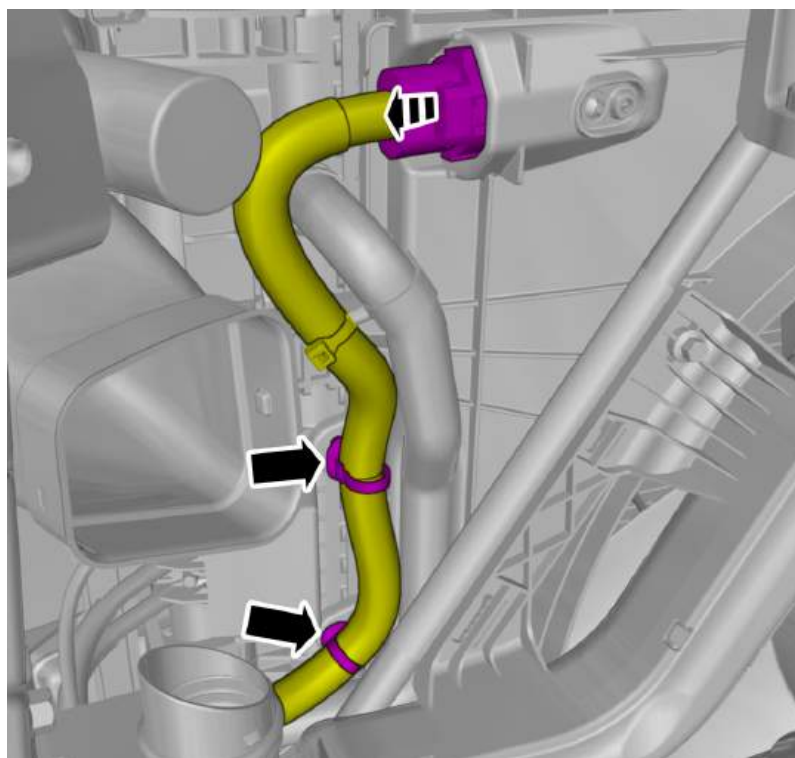

Disconnect the connector.  
Remove the cable harness clips.

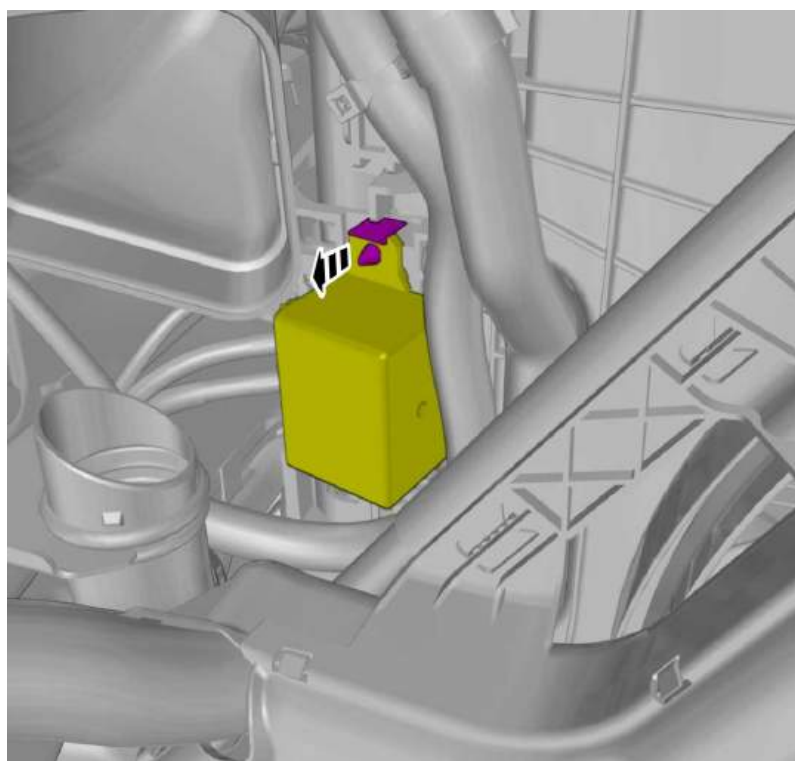

Fold marked part aside.

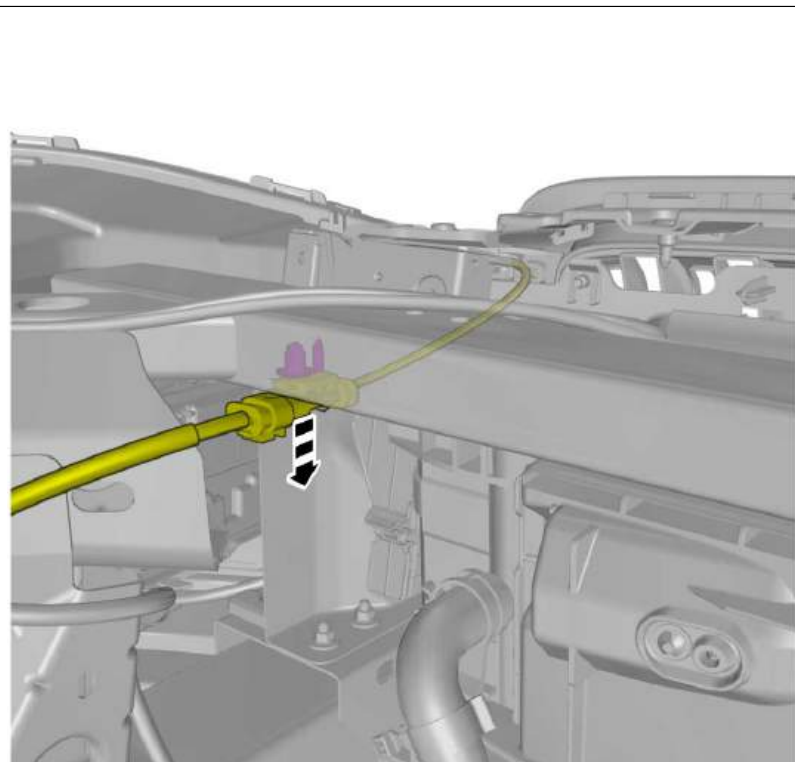

Remove the cable harness clips.

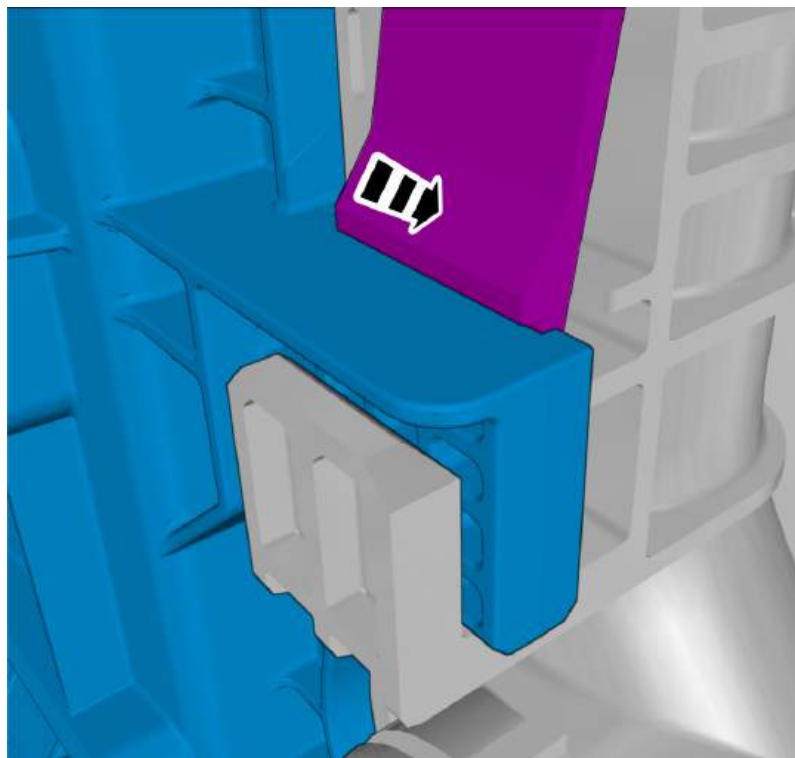

Press the marked component.

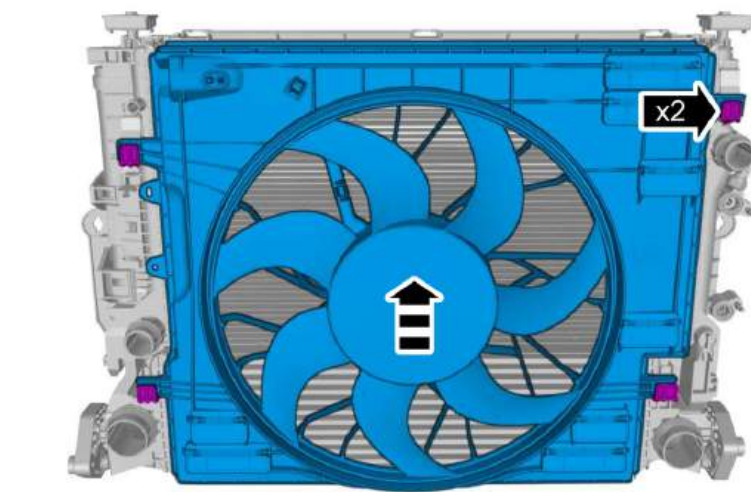

**Hint: It may be necessary to twist or turn the component.**

Remove the marked part.

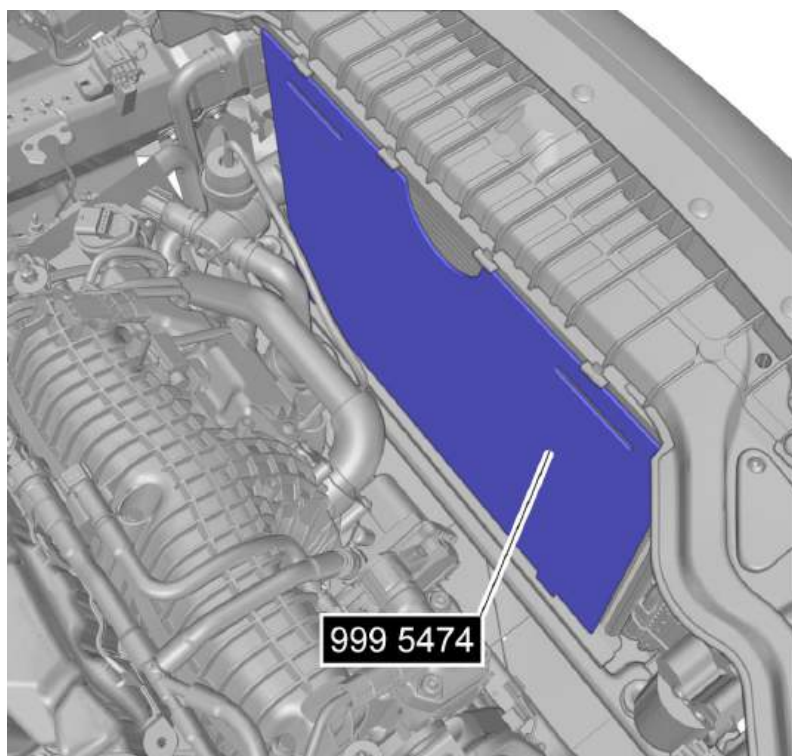

Place the component where indicated in the graphic.

Special Tool: T9995474, RADIATOR PROTECTION

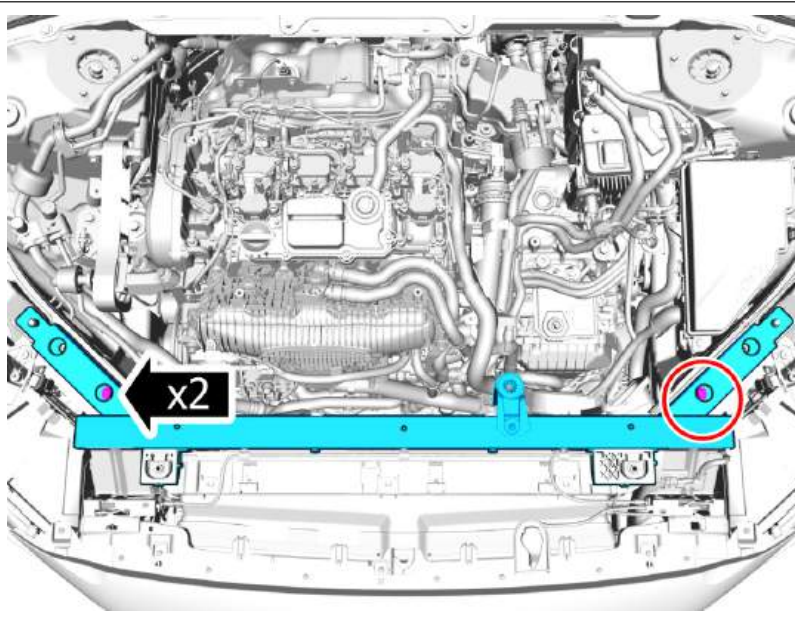

Install the marked component.  
Install the screws.

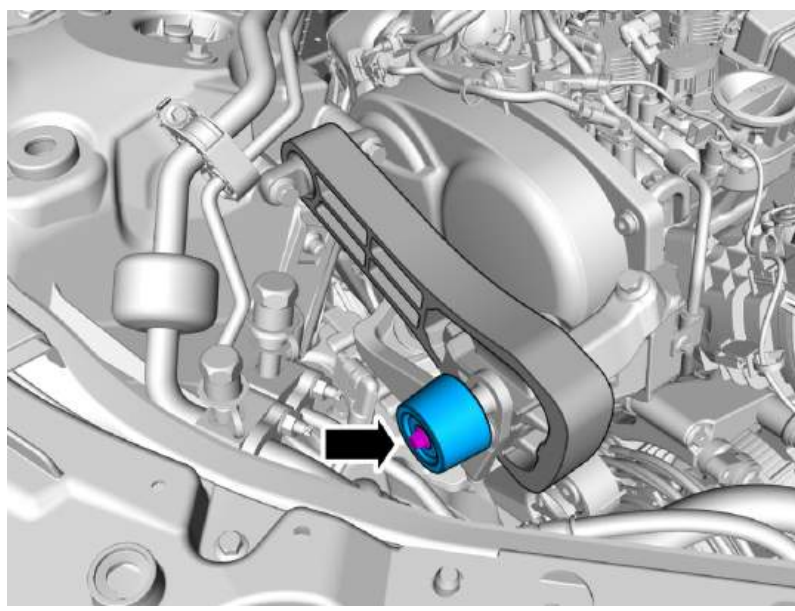

Loosen the screw.  
Remove the marked part.

**Torque:**

M6 , 10 Nm

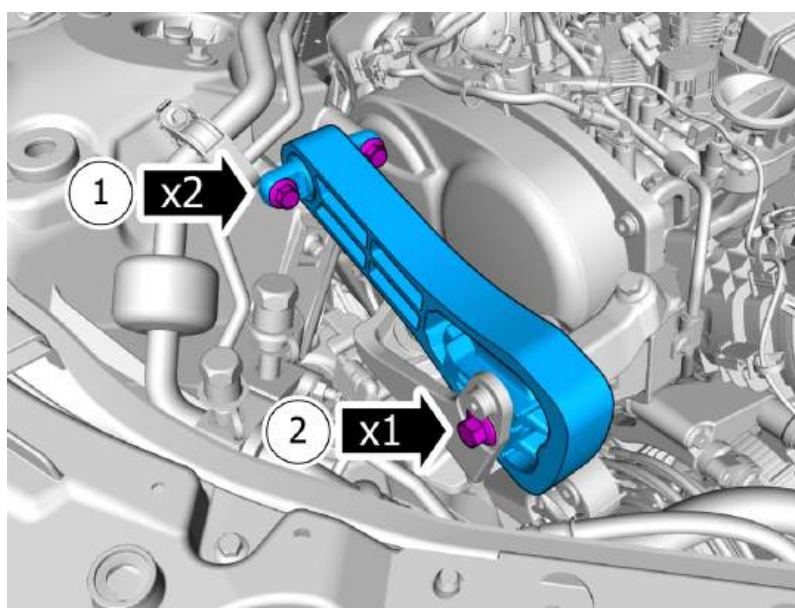

**Note! Make sure to follow the correct sequence during installation.**

Remove the screws.

1 · **Torque:**

Upper torque rod to spring strut turret ,  
60 Nm

2 · **Torque:**

Upper torque rod to engine mount  
bracket , 110 Nm

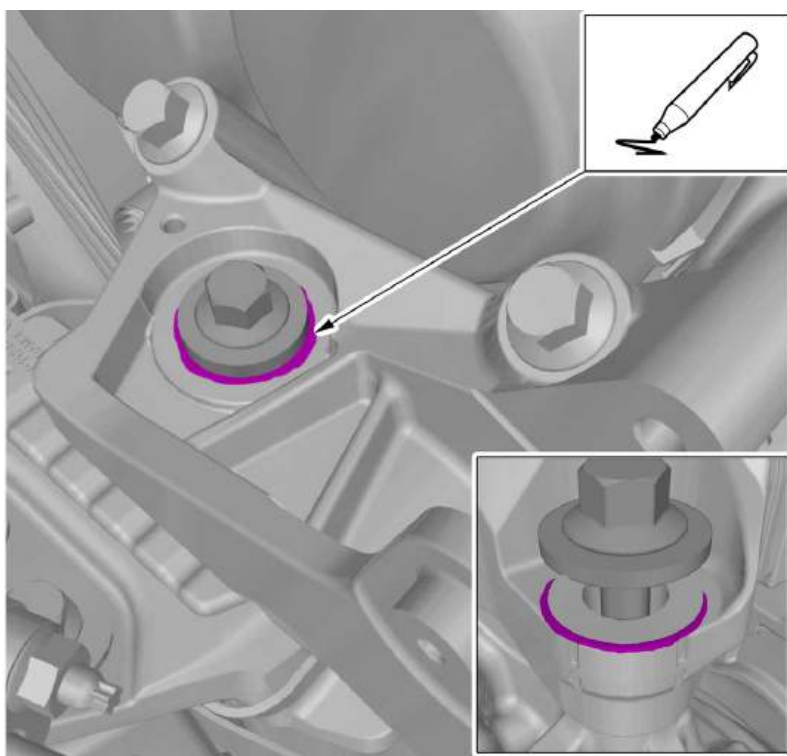

**Caution! Note the position of the component before removal.**

**Use:** Marker pen

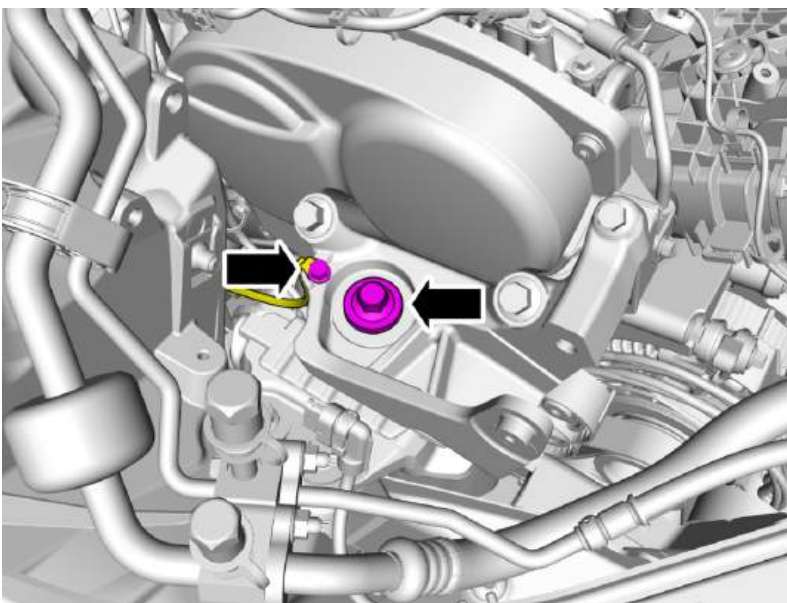

Remove the screws.

- 1 · **Torque:**  
M6 , 10 Nm
- 2 · **Torque:**  
Engine mount bracket, to Engine pad ,  
110 Nm

Remove right side the front wheel , refer to:  
Removal, replacement and installation  
7 - Springs and wheels  
77 - Wheels, tyres  
770 - complete wheels

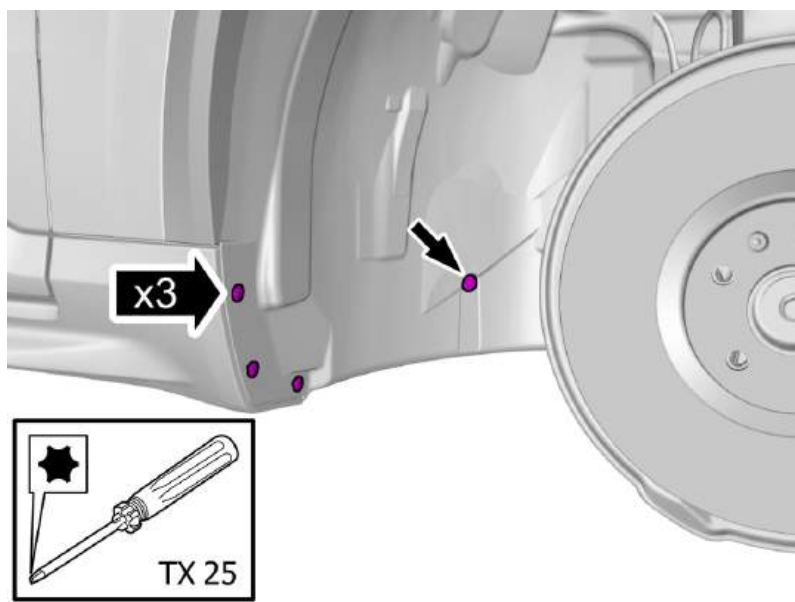

Remove the clip.  
Remove the screws.

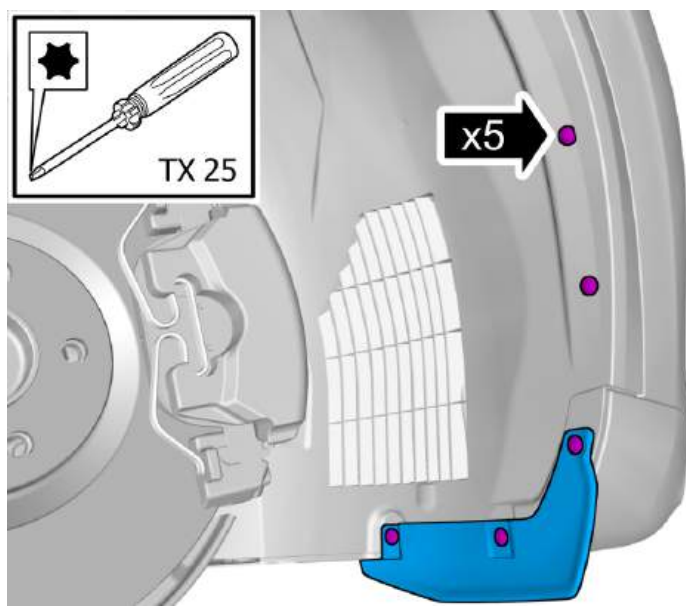

Remove the screws.  
Remove the marked part.

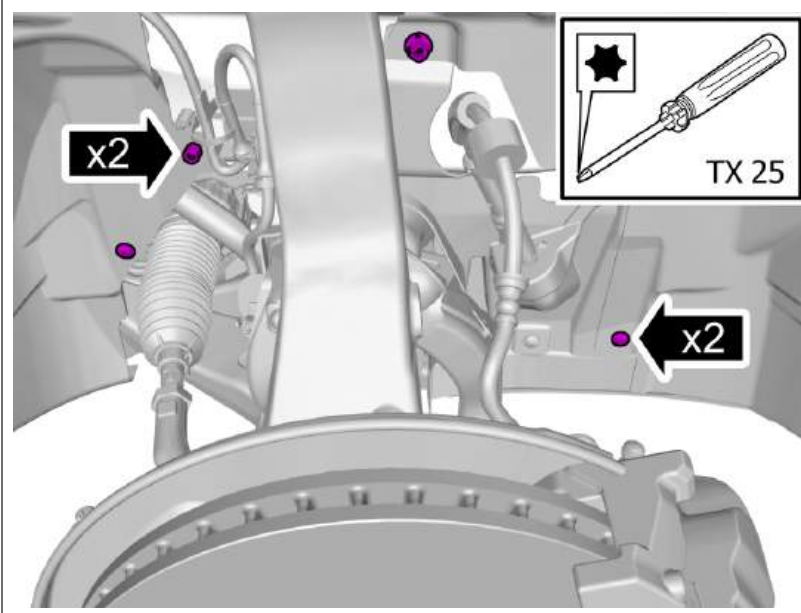

Remove the screws.  
Remove the nuts.

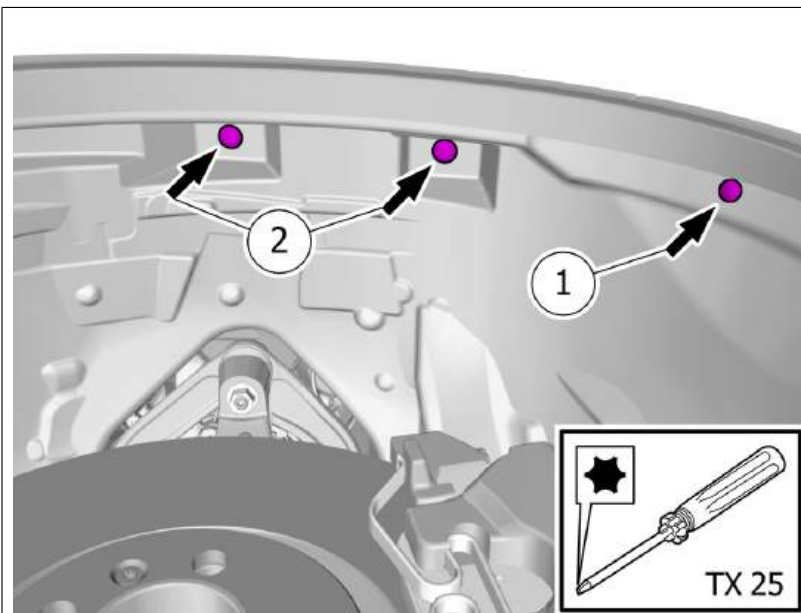

Remove the screw.  
Remove the clips.

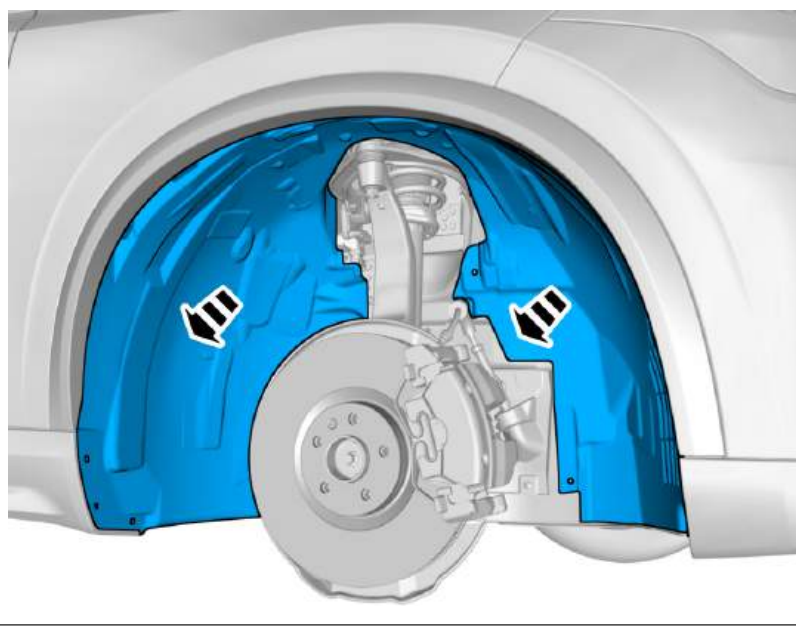

Remove the marked part.

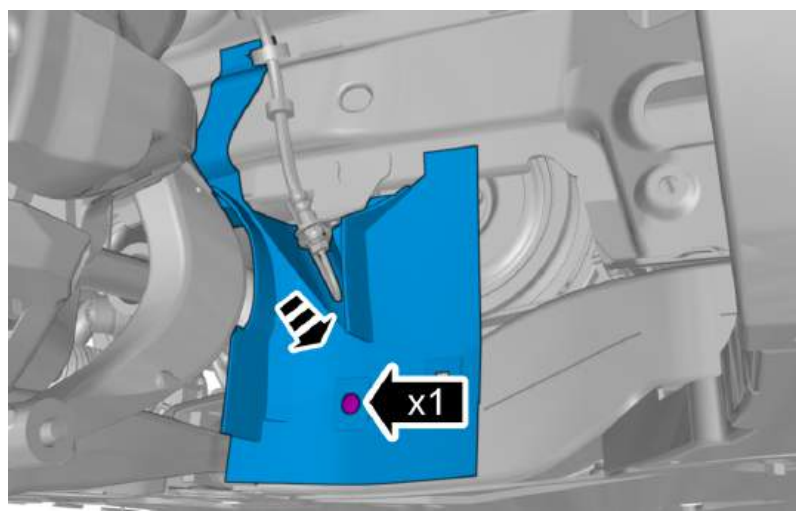

Remove the screw.  
Remove the marked part.

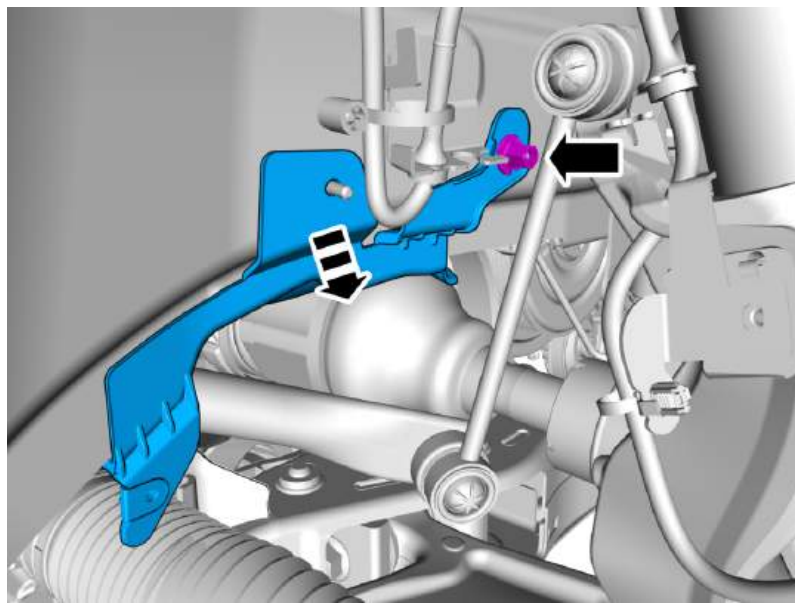

Remove the nut.  
Remove the marked part.

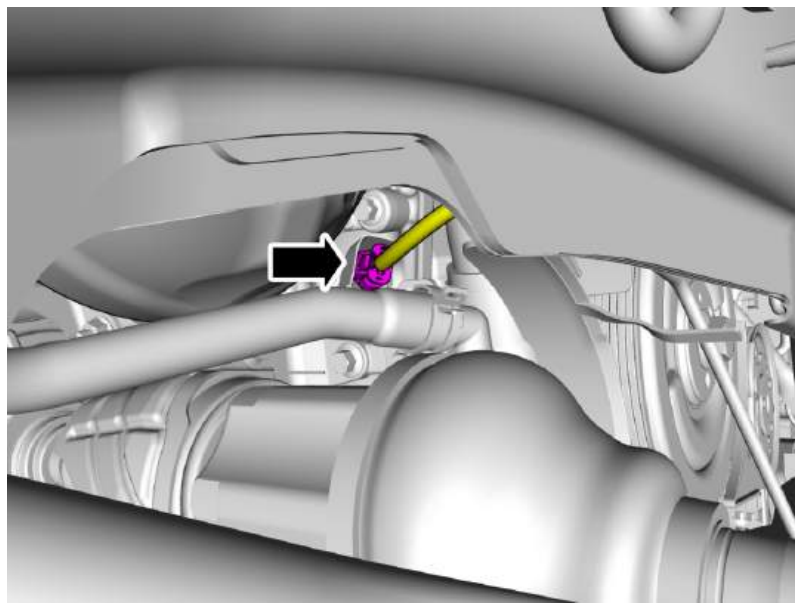

Disconnect the connector.  
Remove the cable harness clips.

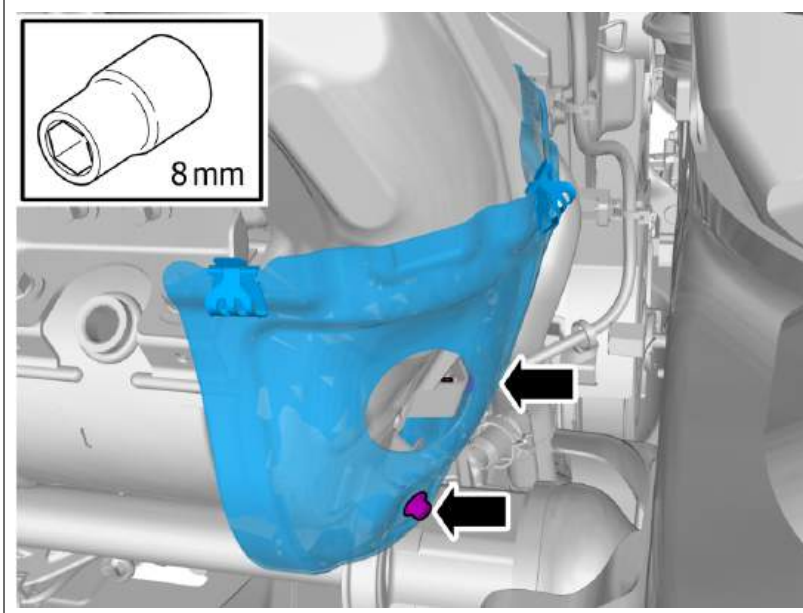

**Note! Do not loosen the bolts more than 2 turns.**

Loosen the screws.

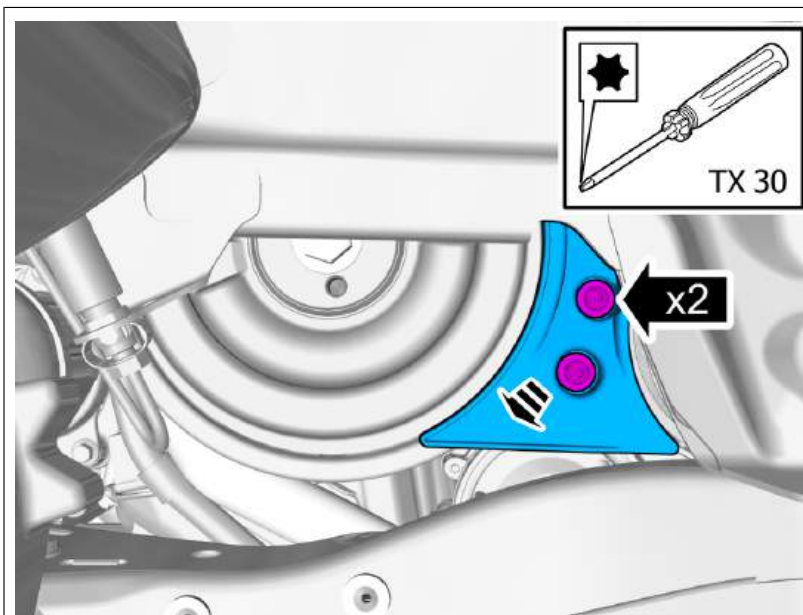

Remove the screws.

Remove the marked part.

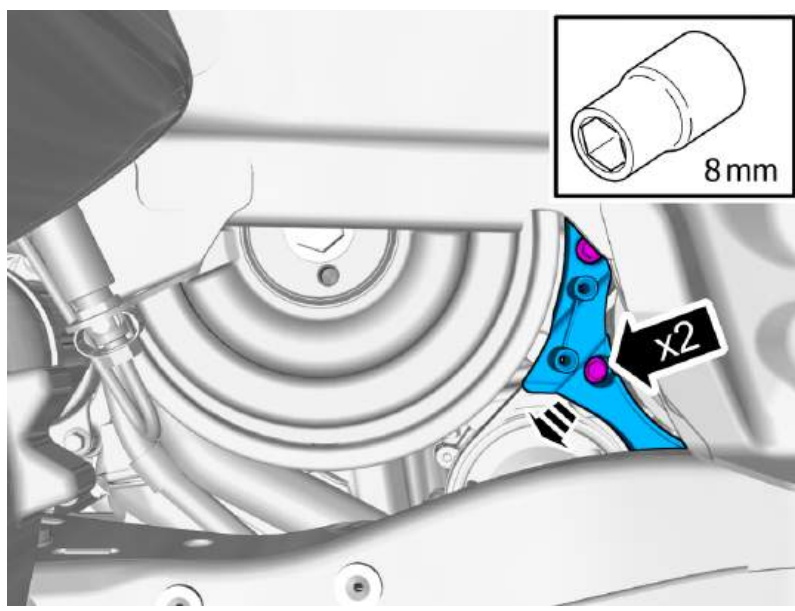

Remove the screws.  
Remove the marked part.

**Torque:**  
M6 , 10 Nm

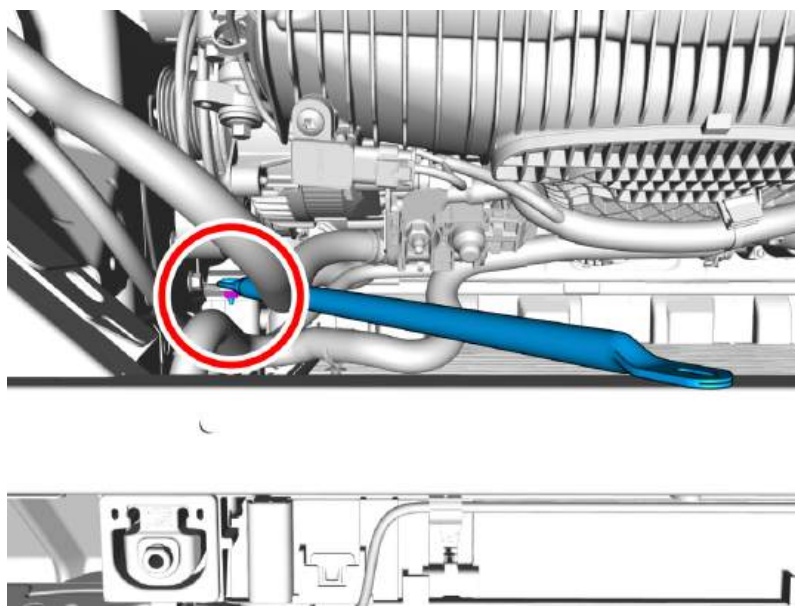

**Note! Orientation view**

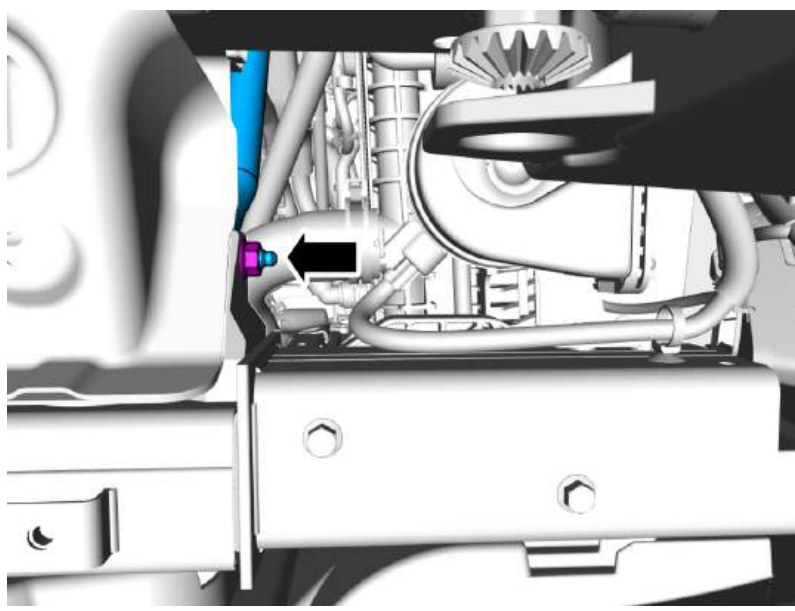

Remove the nut.  
Remove the marked part.

**Torque:**

M8 , 24 Nm

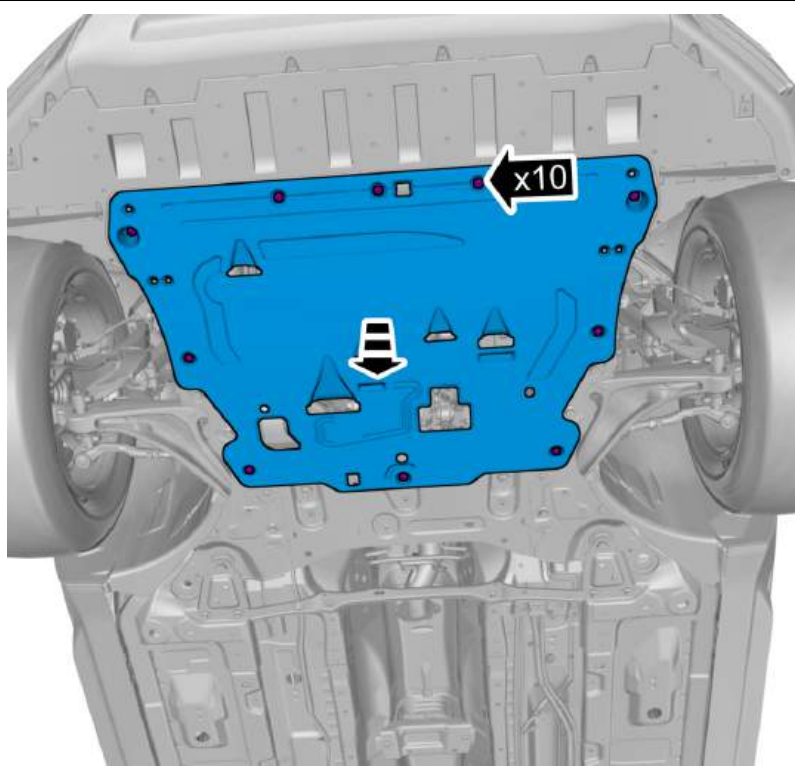

Remove the screws.  
Remove the clips.  
Remove the marked part.

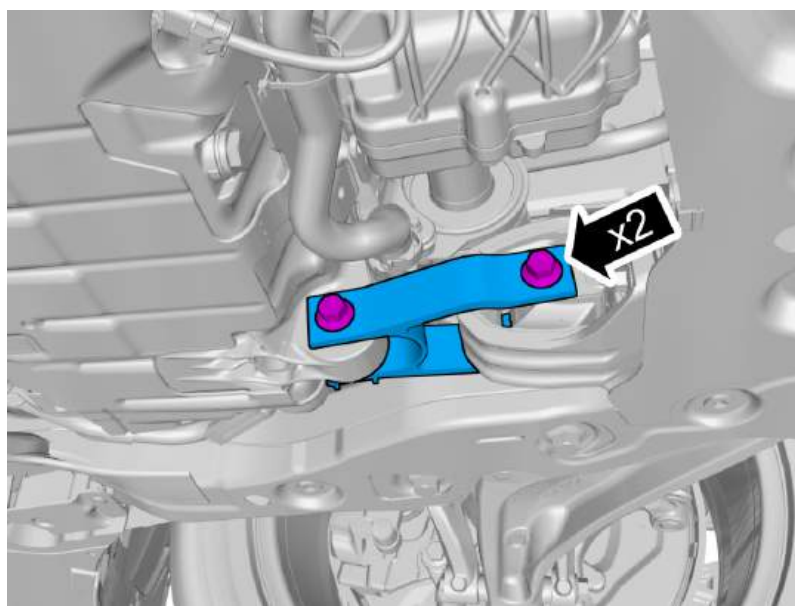

Remove the screws.  
Remove the marked part.

**Torque:**

Lower torque rod rear right, to Engine mount bracket , 110 Nm

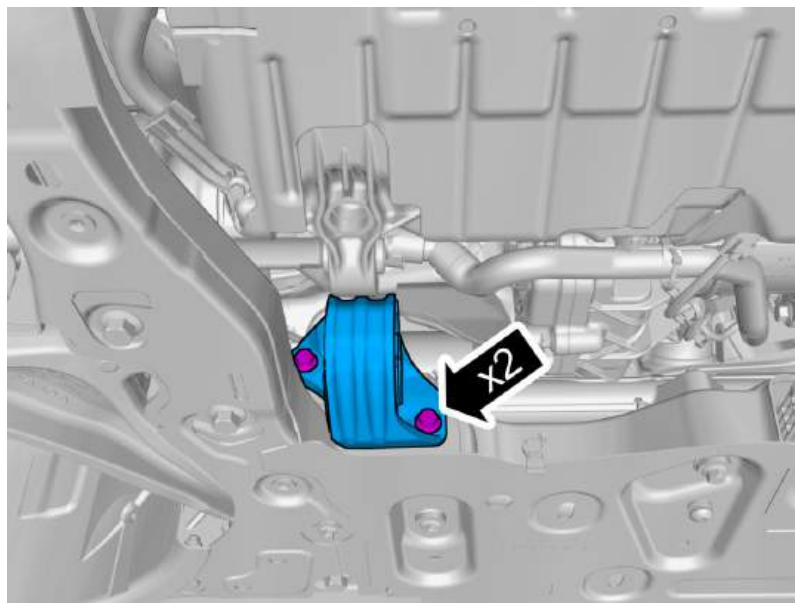

Remove the screws.  
Remove the marked part.

**Torque:**

Lower torque rod rear right, to subframe , 60 Nm

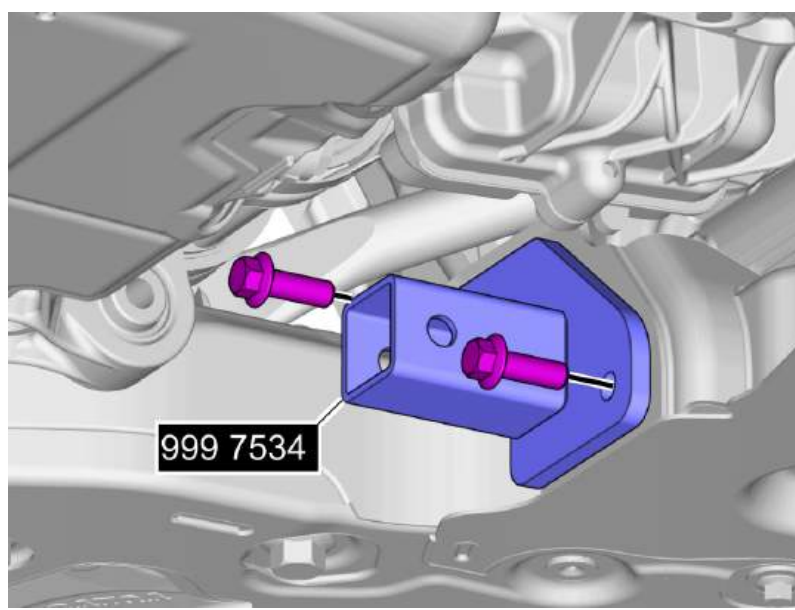

Install the Special tool.  
Install the screws.

**Use:** Screw M10 x 20 mm

Special Tool: T9997534, Mounting

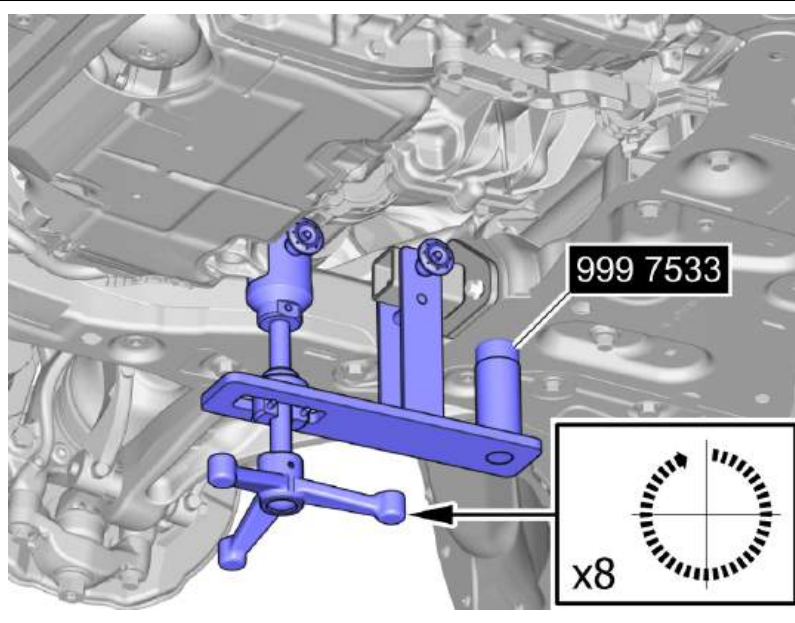

Install the Special tool.  
Adjust to the specified value.

Special Tool: T9997533, Support

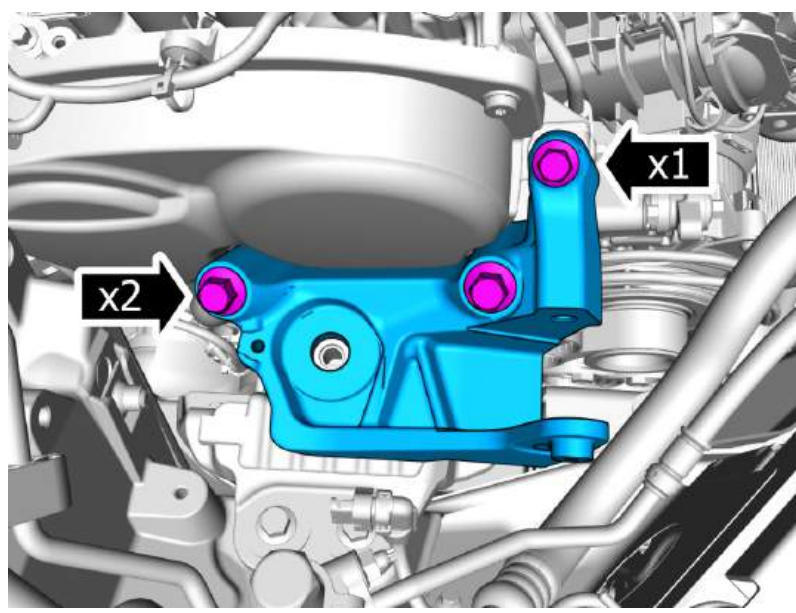

Remove the screws.  
Remove the marked part.

1. **Torque:**
  - Stage 1 : Engine mount bracket, to Cylinder head, M12 , 90 Nm
  - Stage 2 : Engine mount bracket, to Cylinder head, M12 , 130°
2. **Torque:**
  - Engine mount bracket, to Cylinder head, M10 , 60 Nm

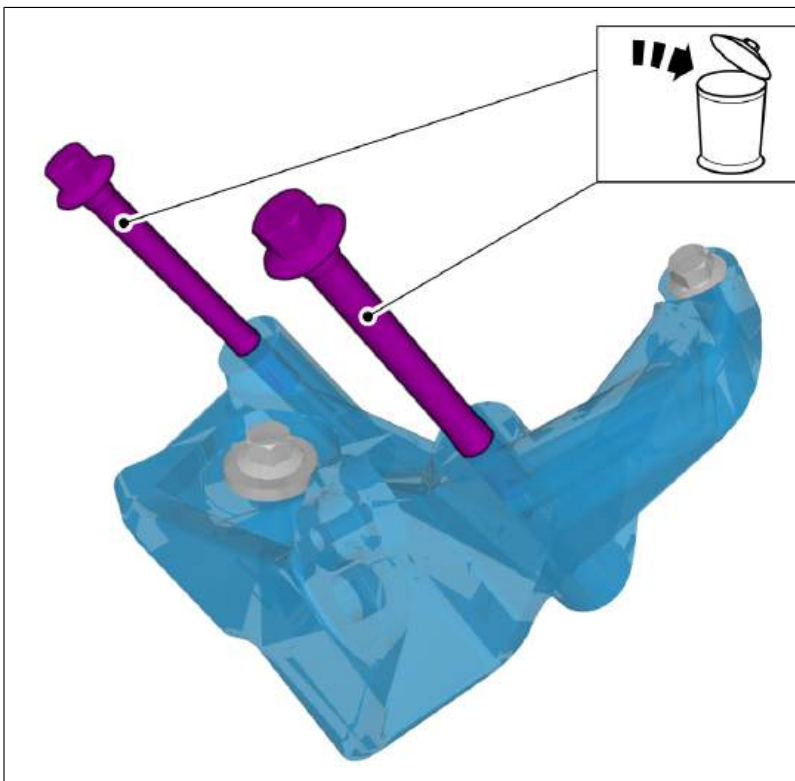

**Caution! Make sure that new bolts are installed.**

Vehicles early version

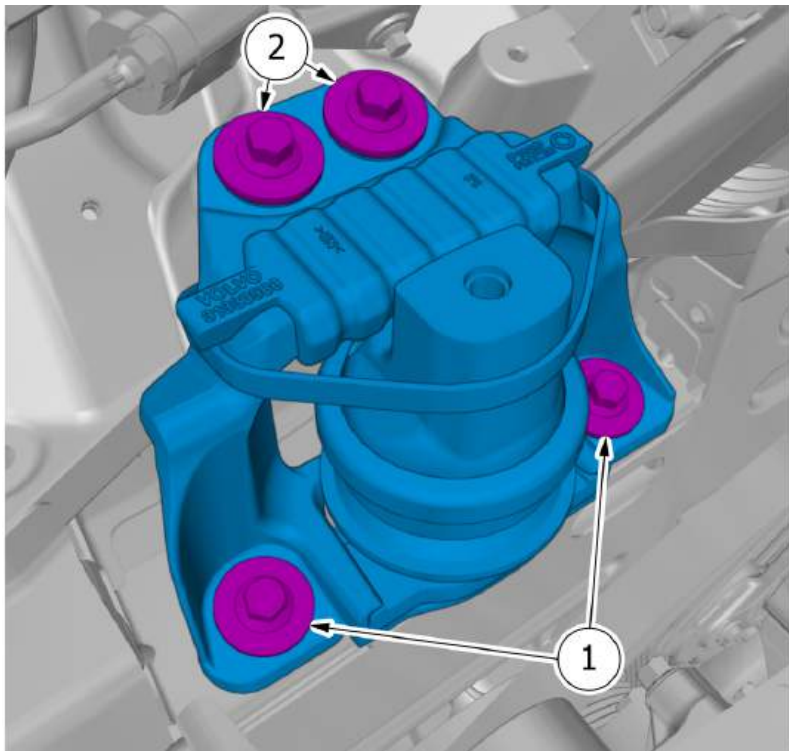

**Note! Make sure to follow the correct sequence during installation.**

Remove the screws.  
Remove the marked part.

**Torque:**

Right-hand engine pad to body frame ,  
60 Nm

Vehicles late version

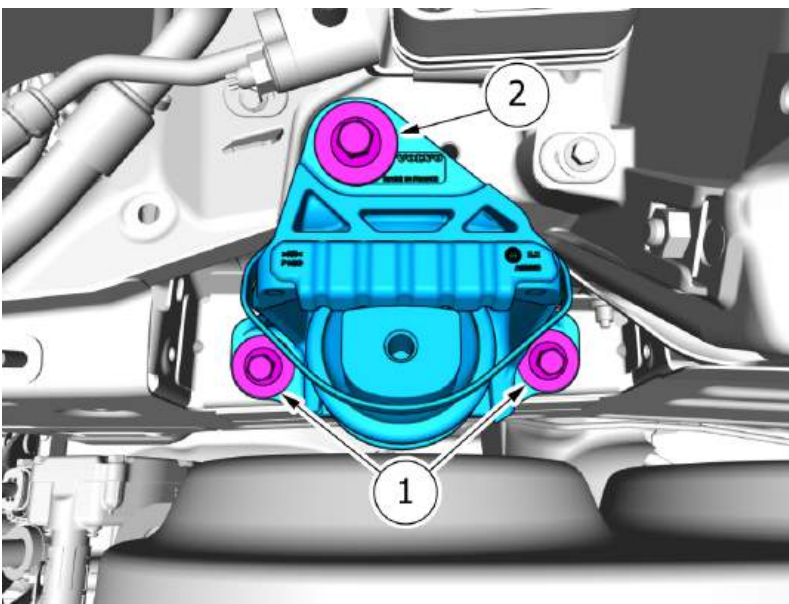

**Note! Make sure to follow the correct sequence during installation.**

Remove the screws.  
Remove the marked part.

**Torque:**

Right-hand engine pad to body frame ,  
60 Nm

All vehicles

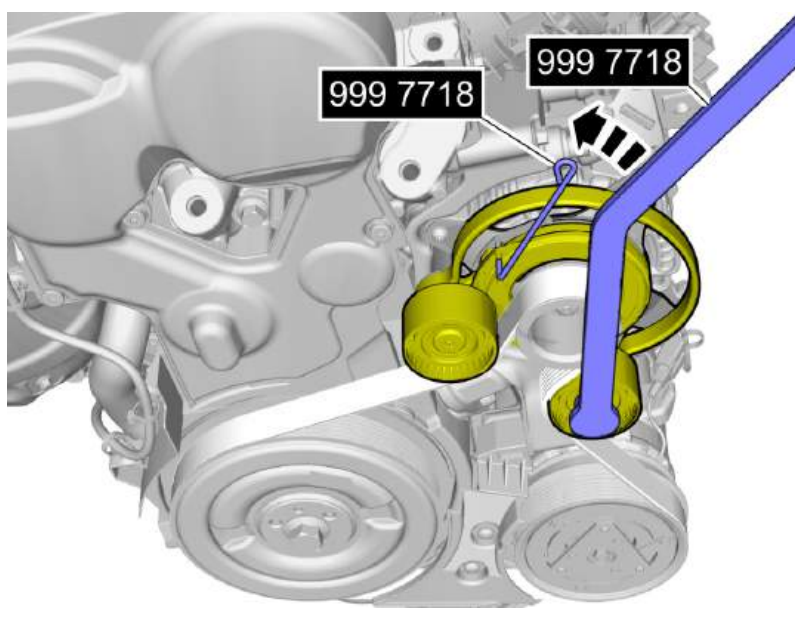

Special Tool: T9997718, Counterhold

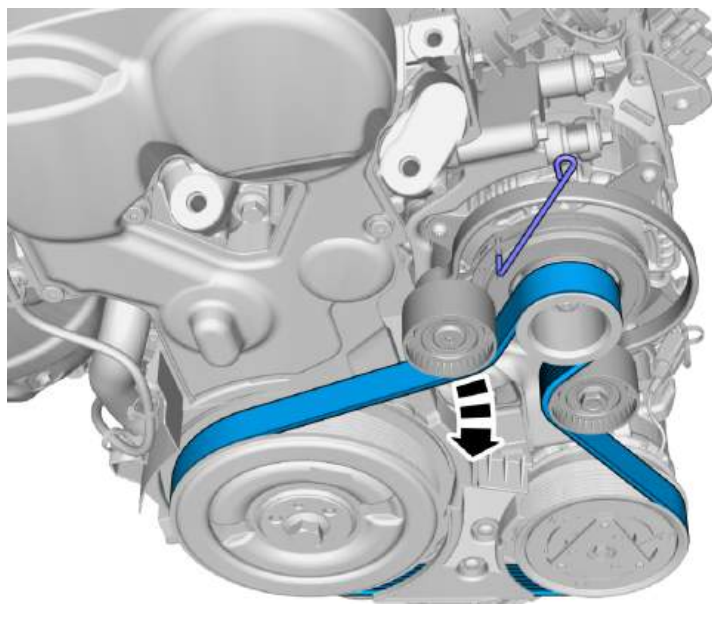

Remove the marked part.

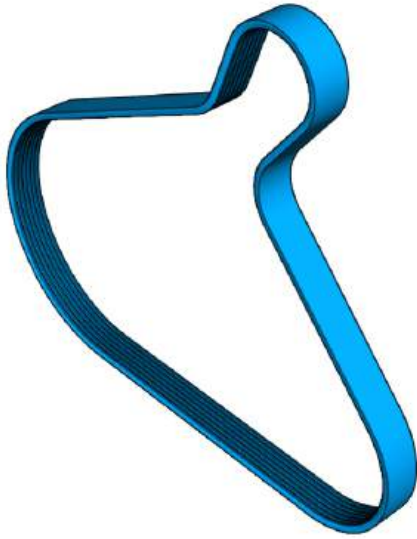

**Note!** The component can be reused unless it has been subjected to abnormal mechanical stress, damage or oil contamination.

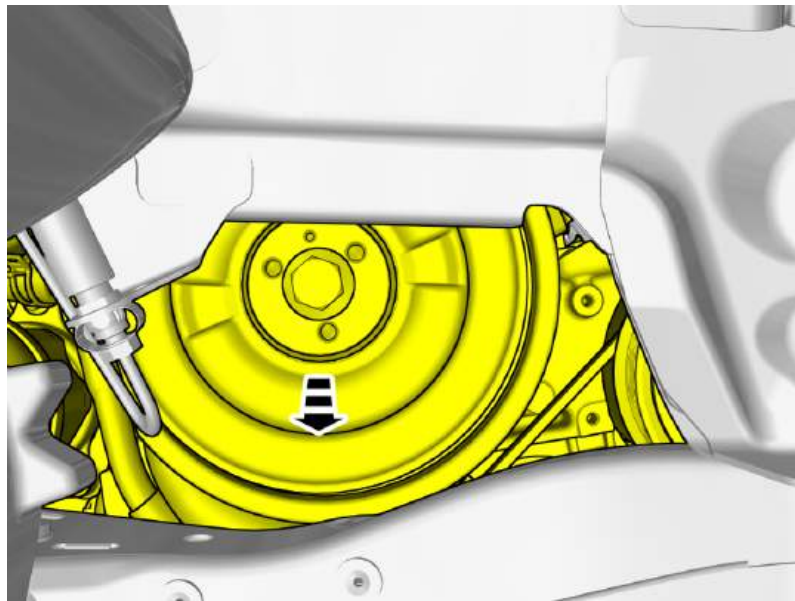

Lower the engine.

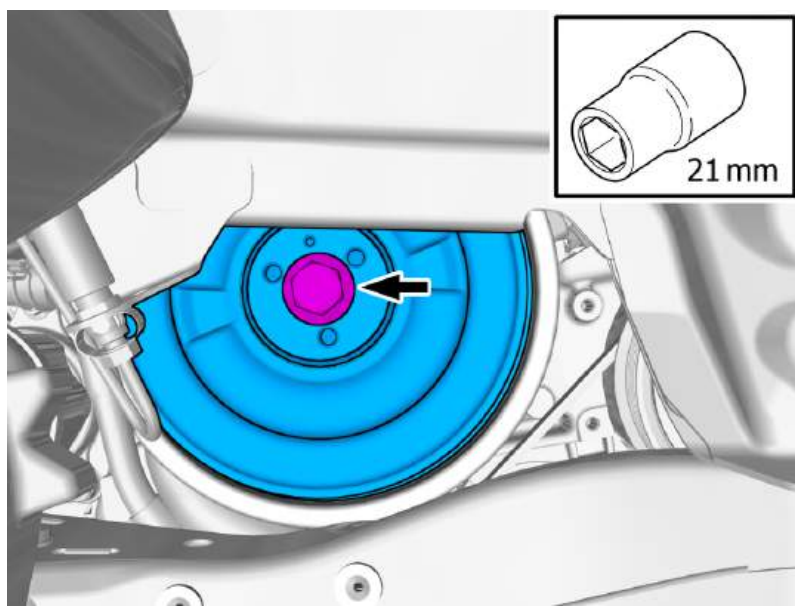

**Note!** Note the position of the component before removal.

**Extra information**

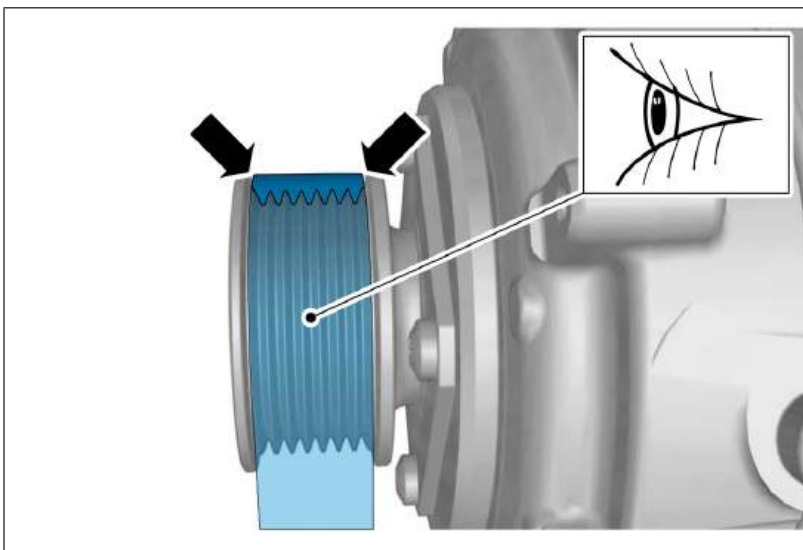

**Caution!** Make sure that the component is positioned correctly.

Continue the removal following the steps below.

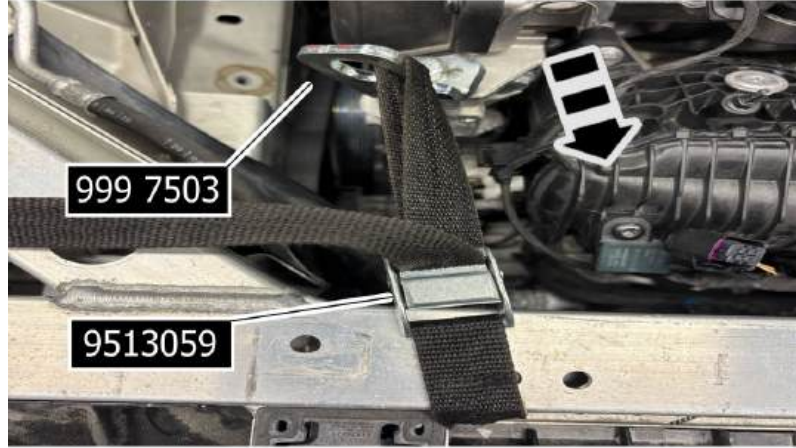

Install the Special tool.  
Pull the component in direction of the arrow.

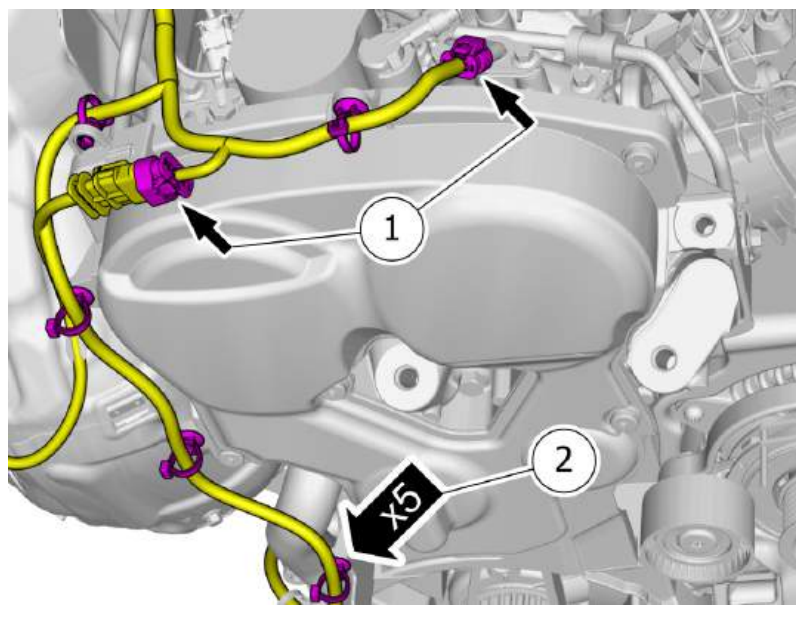

Disconnect the connectors.  
Remove the cable harness clips.

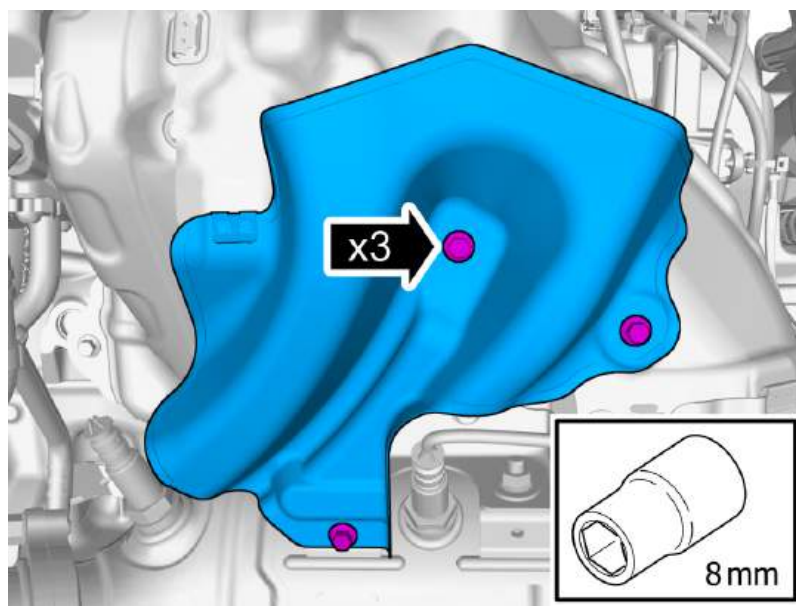

Remove the screws.  
Remove the marked part.

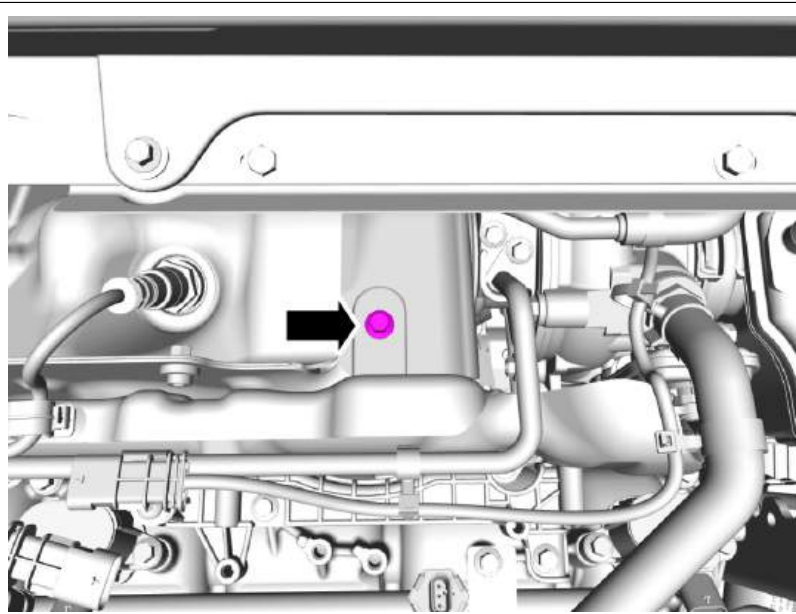

Remove the screw.

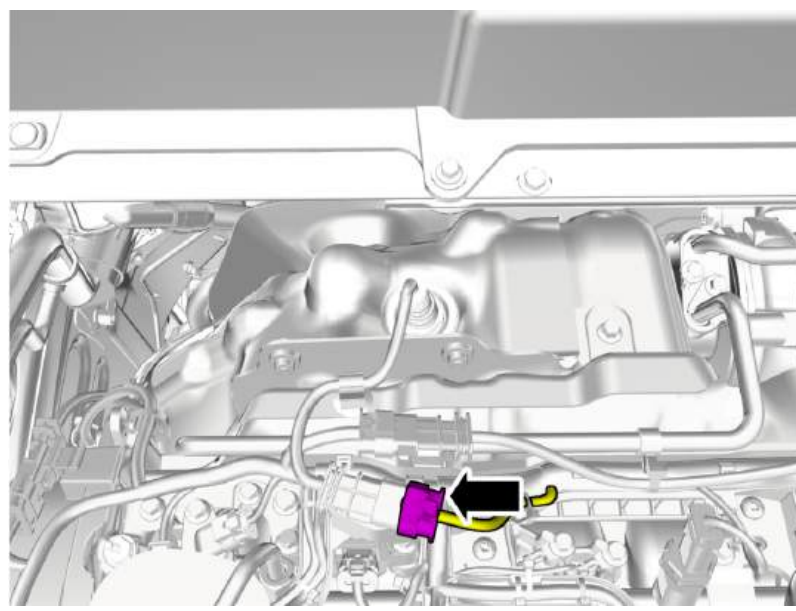

Disconnect the connector.

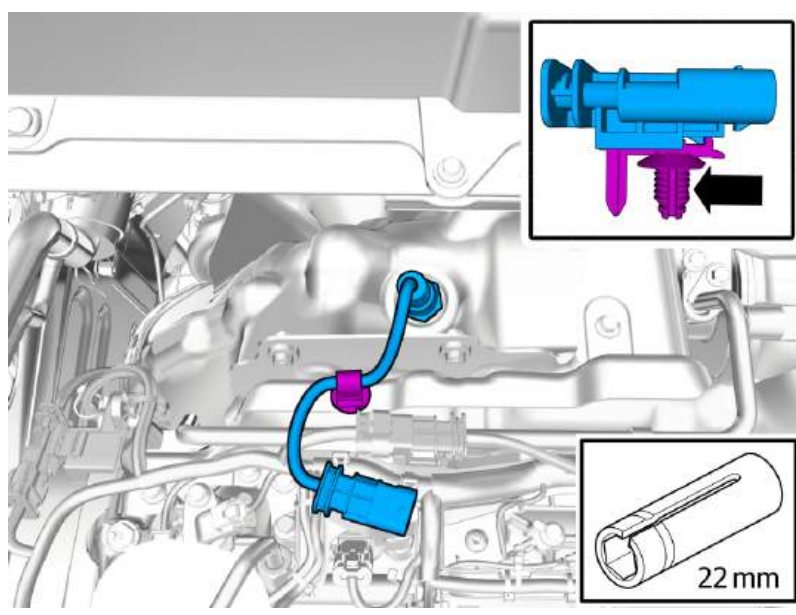

Loosen the clips.  
Remove the marked part.

**Torque:**

Lambda probe, tightening , 45 Nm

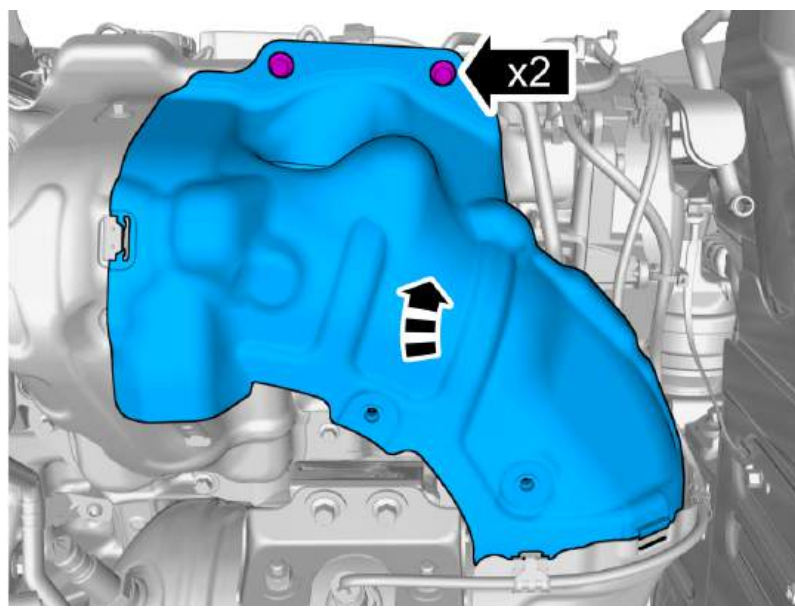

Remove the screws.  
Remove the marked part.

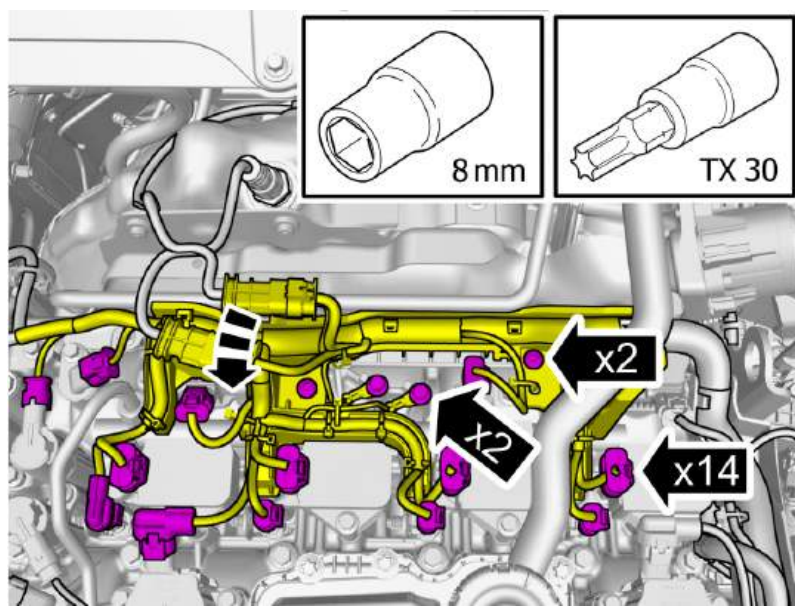

Remove the screws.  
Disconnect the connectors.  
Fold marked part aside.

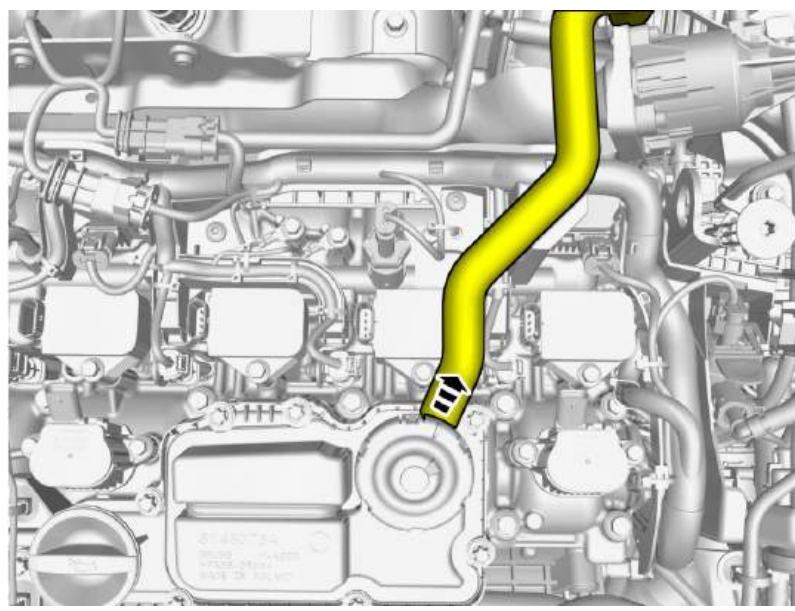

Undo the hose from the connection.  
Fold marked part aside.

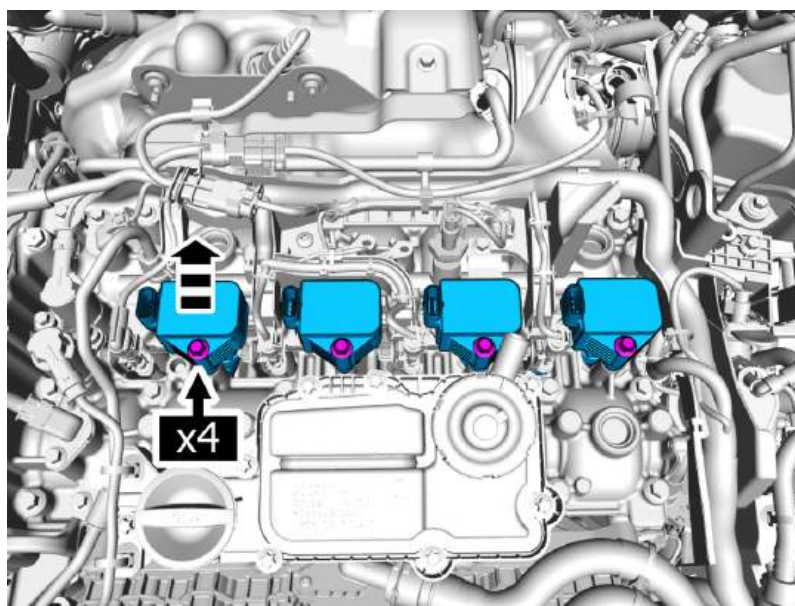

Remove the screws.  
Remove the marked parts.

**Torque:**

M6 , 10 Nm

## Extra information

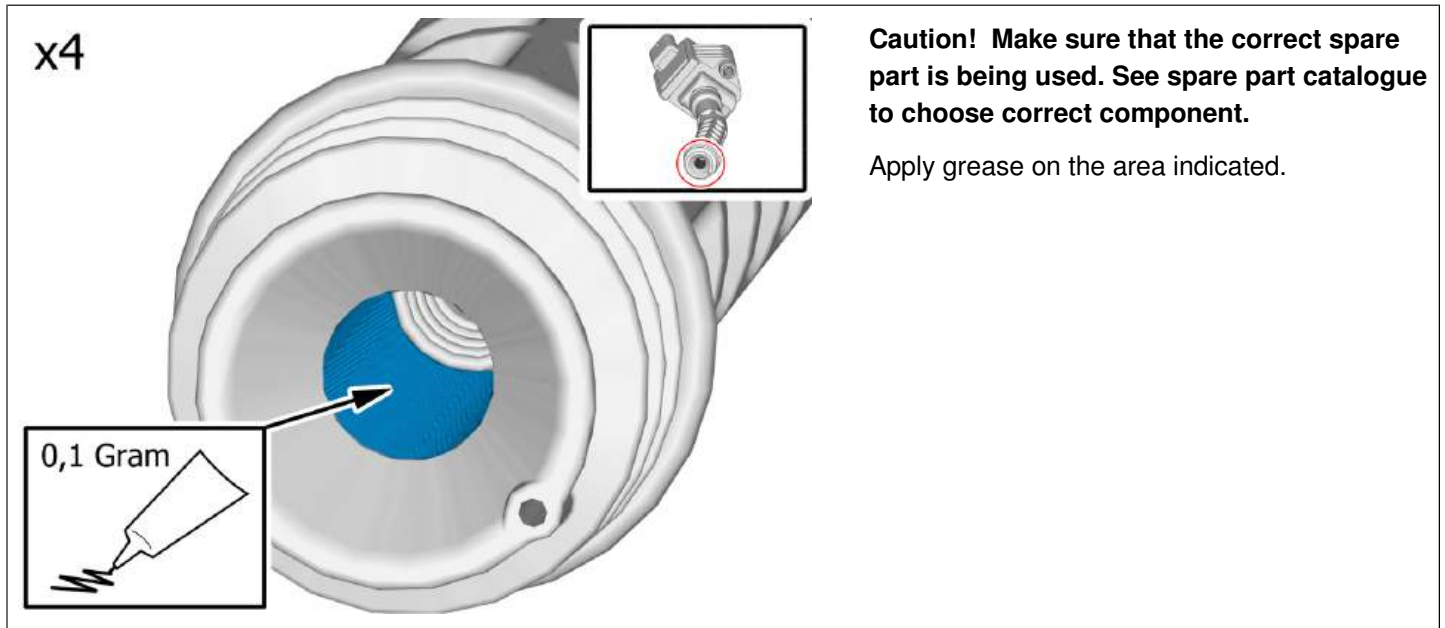

Continue the removal following the steps below.

Vehicles early version

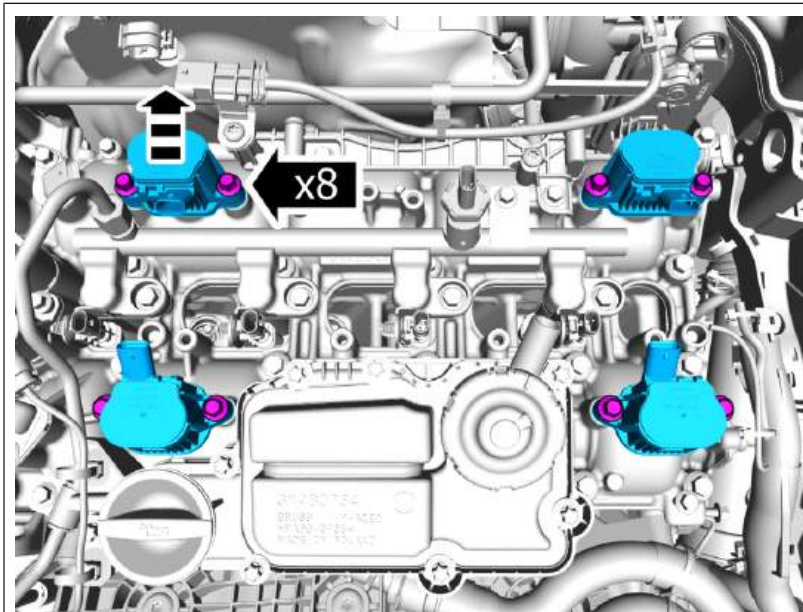

**Caution! The component must be removed by hand. Tools may not be used.**

**Note! Use new seals.**

Remove the screws.  
Remove the marked parts.

**Torque:**

M6 , 10 Nm

All vehicles

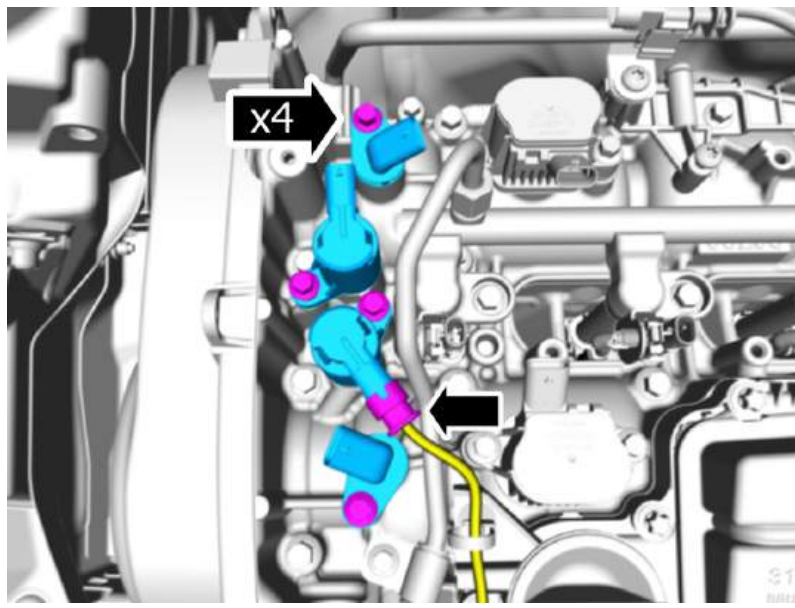
**Note! Use new seals.**

Disconnect the connector.  
Remove the screws.  
Remove the marked parts.

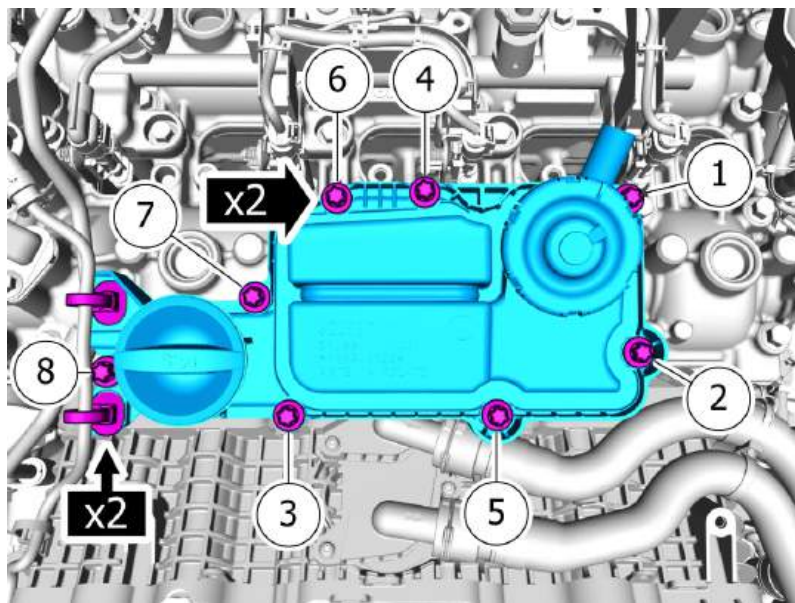
**Note! Make sure to follow the correct sequence during installation.****Note! Use a new seal.**

Remove the clips.  
Remove the screws.  
Remove the marked part.

**Torque:**

M6 , 10 Nm

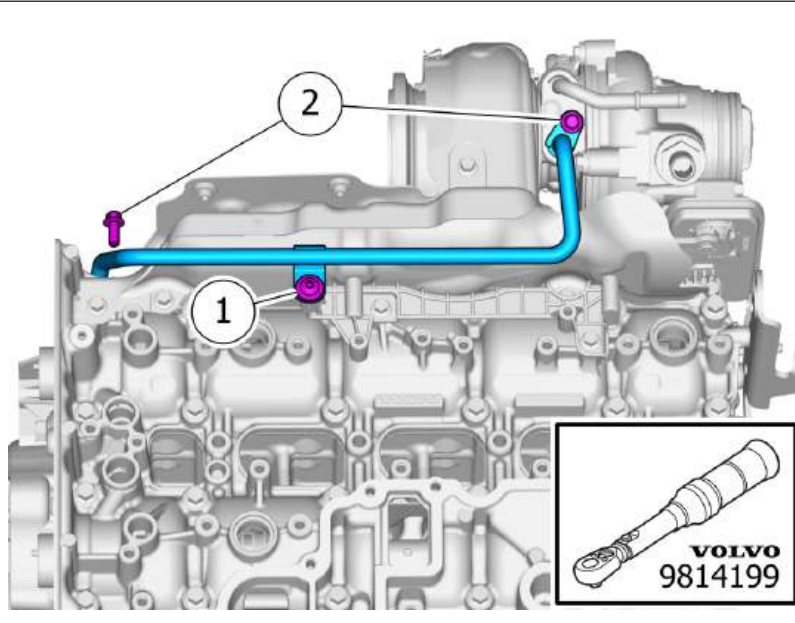

**Note! Use new seals.**

Remove the screws.  
Remove the marked part.

- 1 · **Torque:**  
M5 , 5 Nm
- 2 · **Torque:**  
M6 , 10 Nm

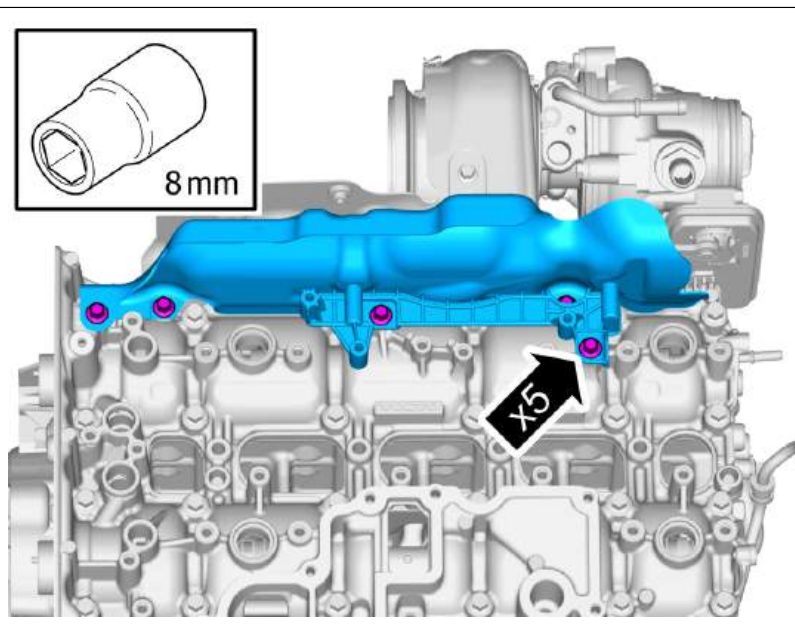

Remove the screws.  
Remove the marked part.

**Torque:**  
M6 , 10 Nm



Remove the Special Tool.

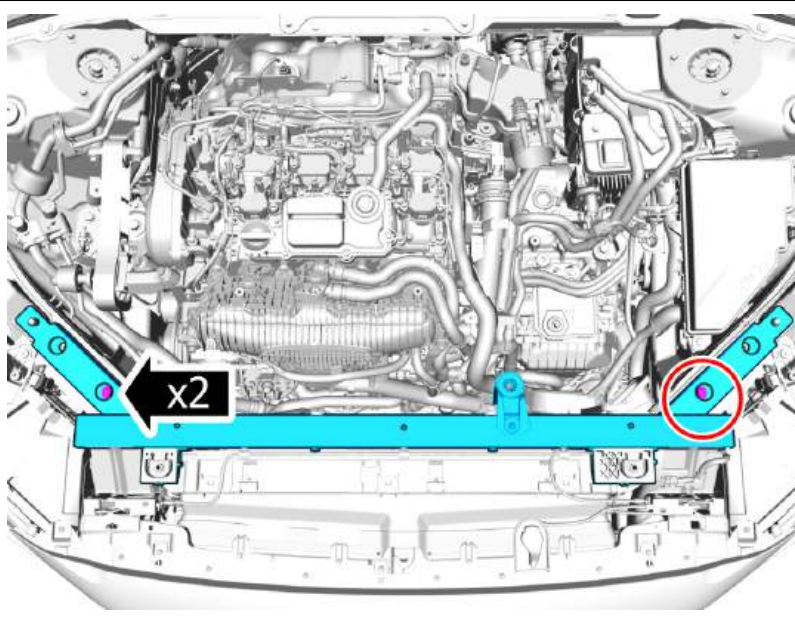

Remove the screws.  
Remove the marked part.

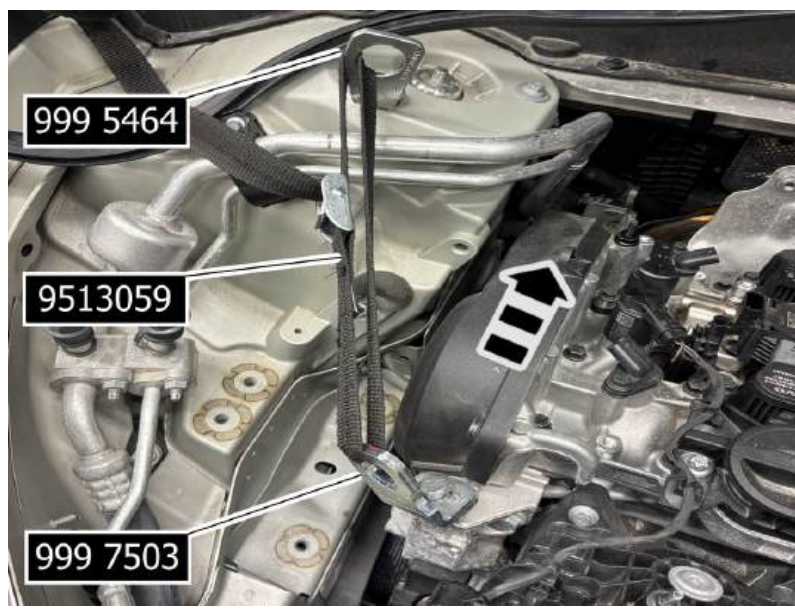

Install the Special tool.  
Pull the component in direction of the arrow.

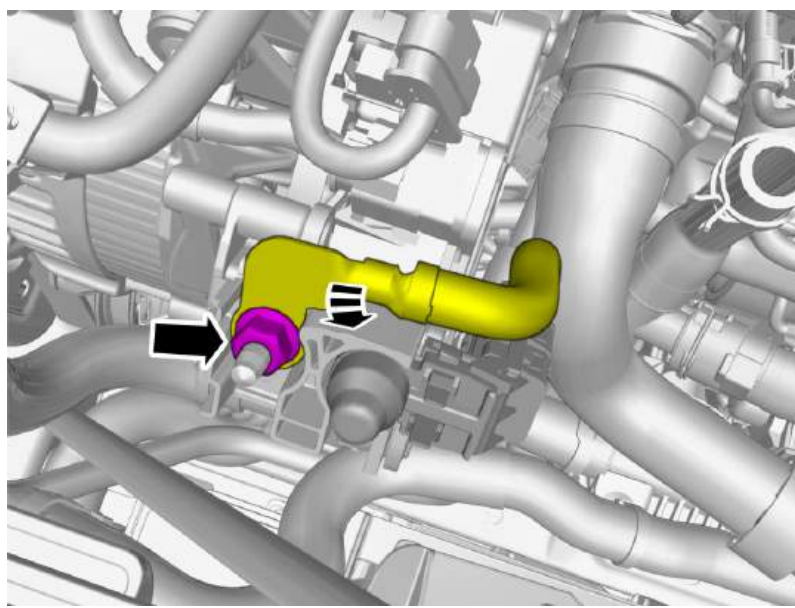

Remove the nut.

**Torque:**

M8 , 24 Nm

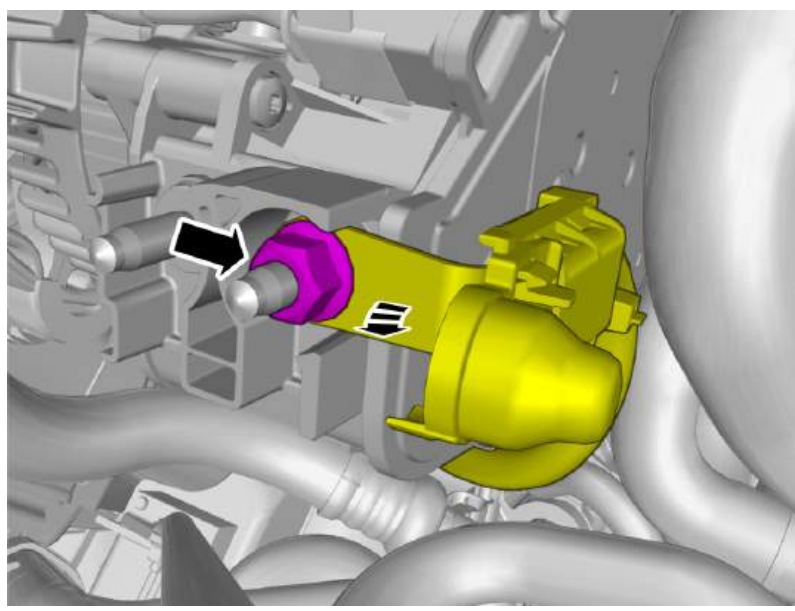

Remove the nut.

**Torque:**

M8 , 24 Nm

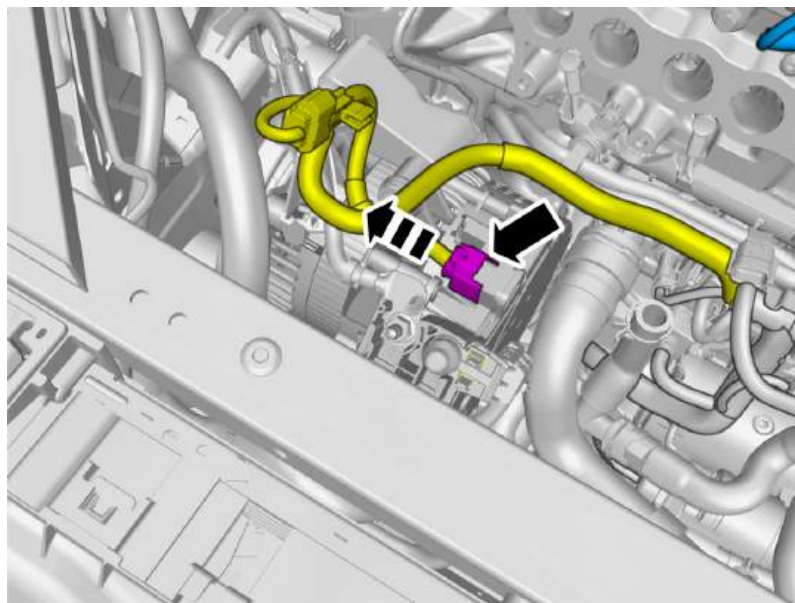

Disconnect the connector.

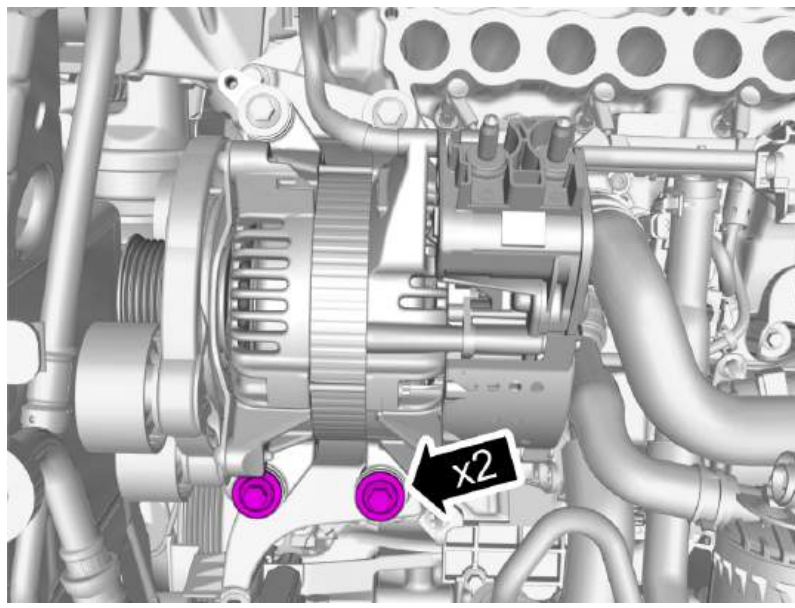

Remove the screws.

**Torque:**

M8 , 24 Nm

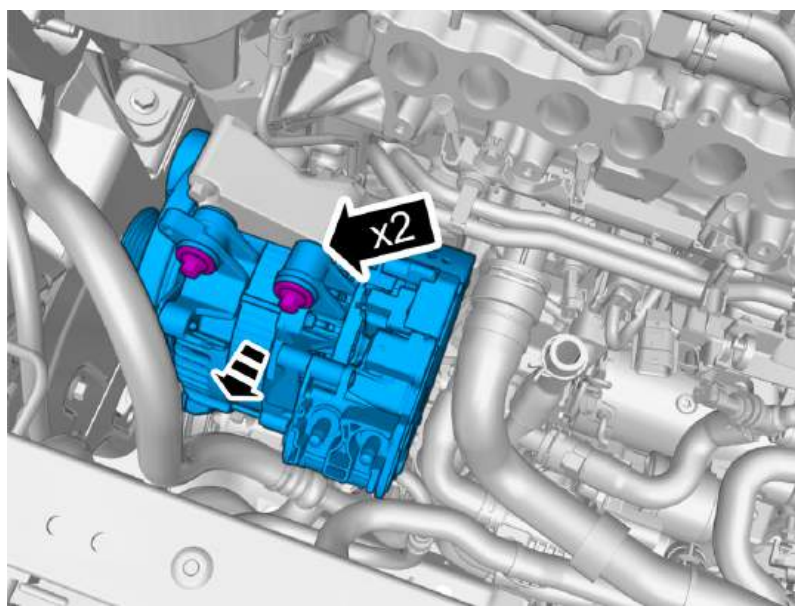

Remove the screws.

Remove the marked part.

**Hint: It may be necessary to twist or turn the component.**

**Torque:**

M8 , 24 Nm

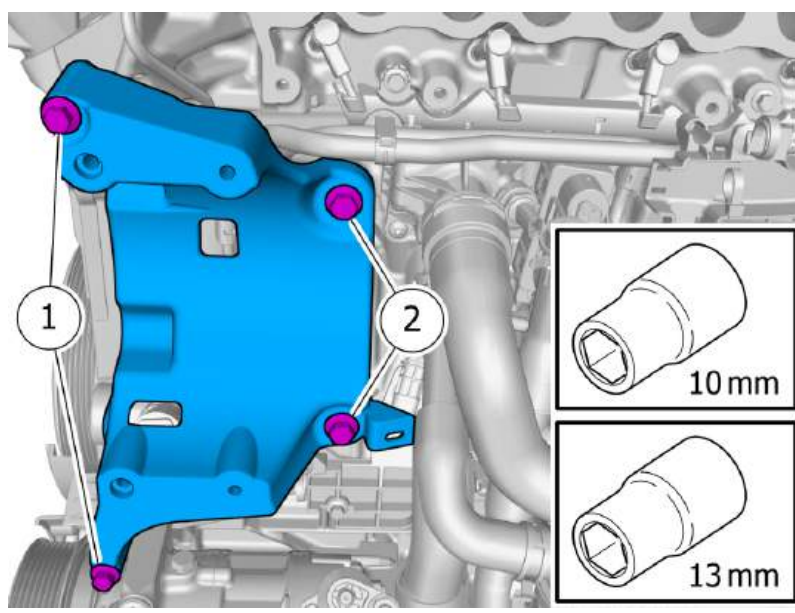

Remove the screws.  
Remove the marked part.

- 1 · **Torque:**  
M8 , 24 Nm
- 2 · **Torque:**  
M10 , 50 Nm

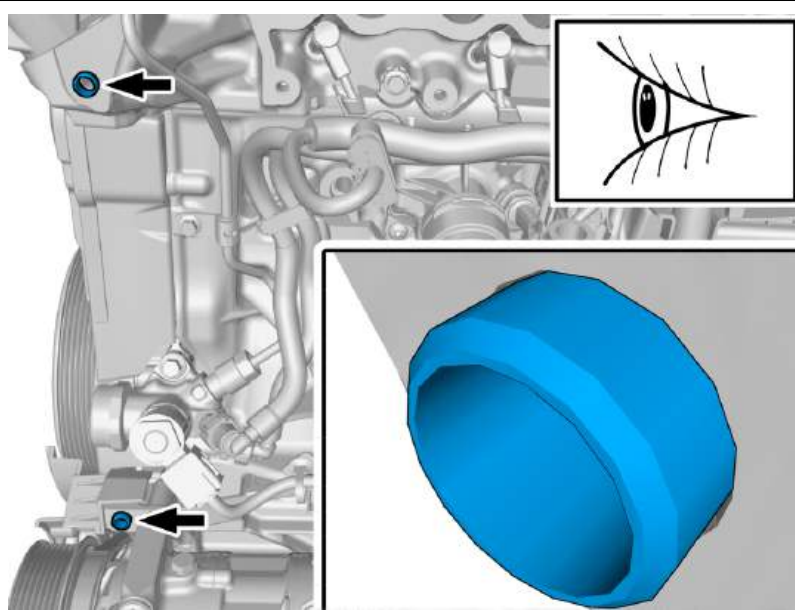

**Note! Make sure that the component is installed.**

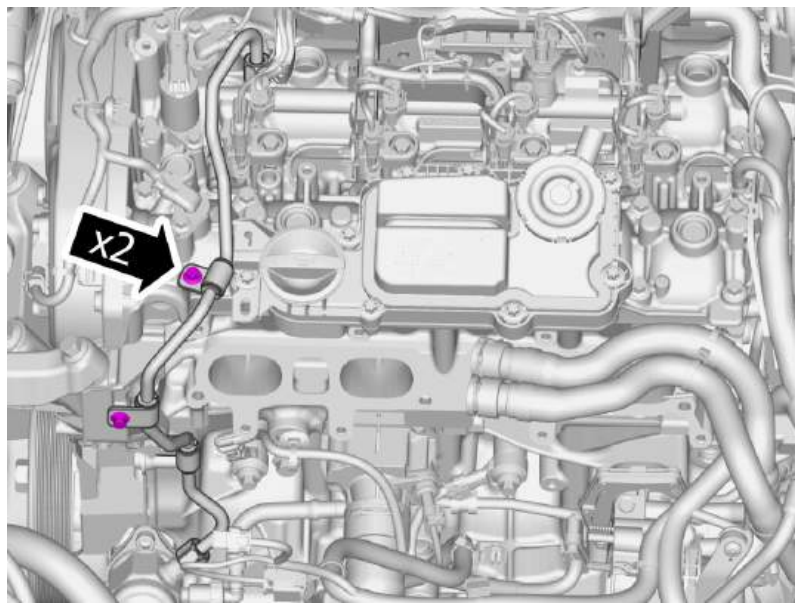

Remove the screws.

**Torque:**

M6 , 10 Nm

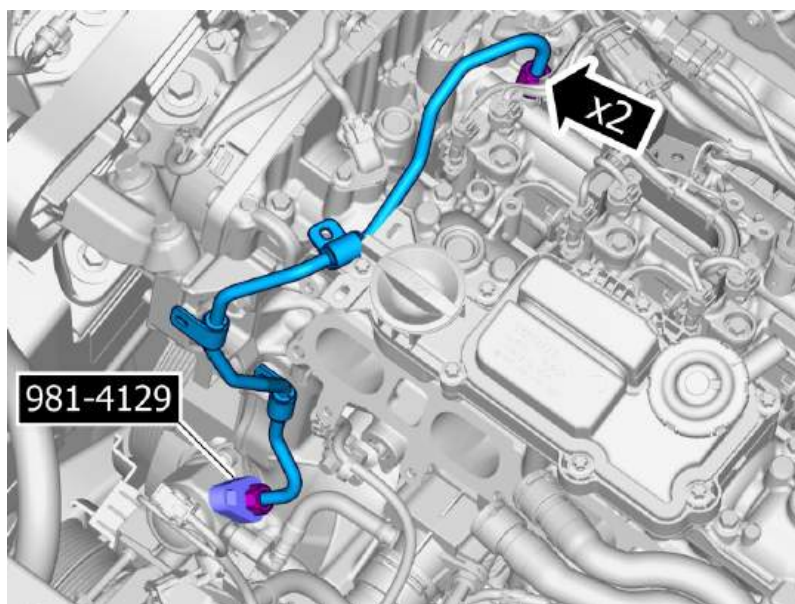

**Warning!** Be prepared to collect escaping fluid.

**Caution!** Make sure that the area around the component is clean and free of foreign material.

**Note!** Make sure that a new component is installed.

Remove the nuts.

Remove the marked part.

Special Tool: T9814129, Hook wrench

**Torque:**

- Stage 1 : High-Pressure Fuel Line to Fuel Pump , 18 Nm
- Stage 2 : High-Pressure Fuel Line to Fuel Pump , 30 Nm

Release the locks.

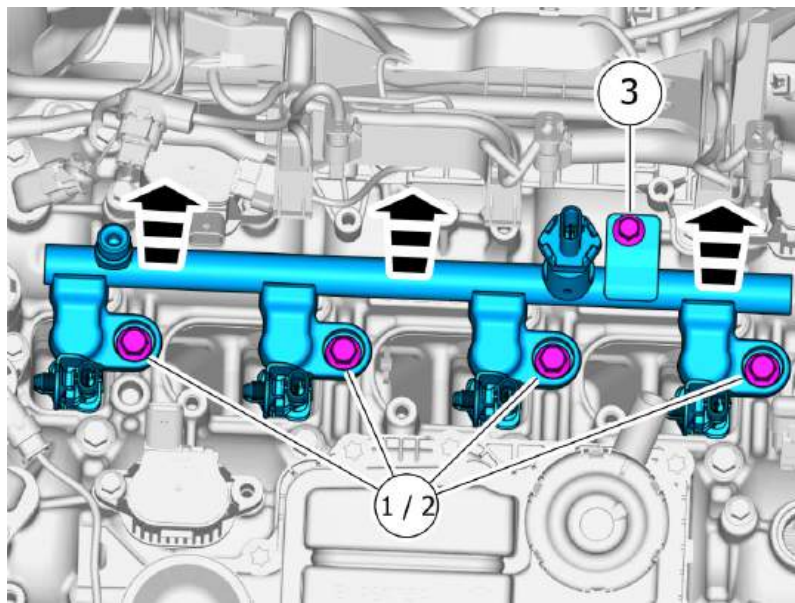
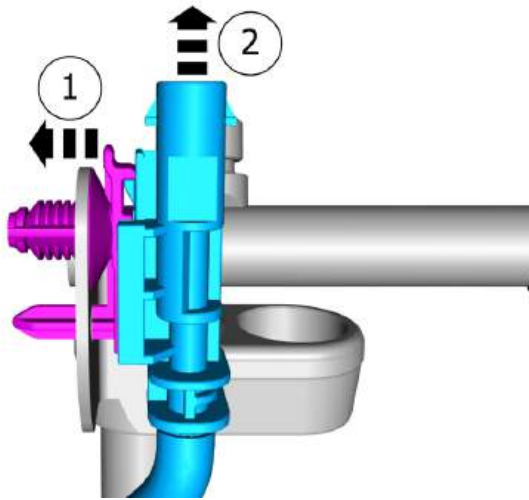

**Caution!** Make sure that the area around the component is clean and free of foreign material.

**Caution!** In order to avoid damage to the injectors, the part must be carefully pulled straight up.

**Caution!** Be extra careful when removing or installing this component.

Remove the screws.

Remove the part carefully

- 1 · **Torque:**  
Fuel rail M7 , 22 Nm
- 2 · **Torque:**  
Fuel rail M8 , 30 Nm
- 3 · **Torque:**  
M6 , 10 Nm

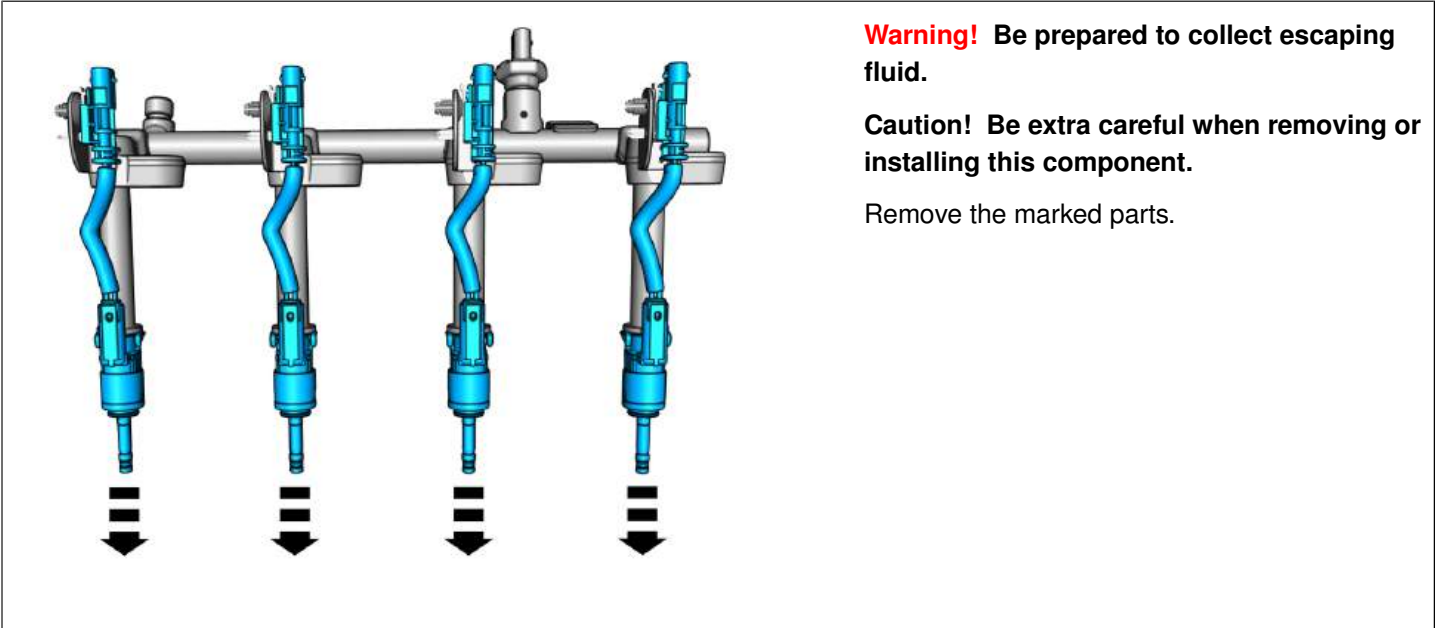

When necessary, perform the following instruction.

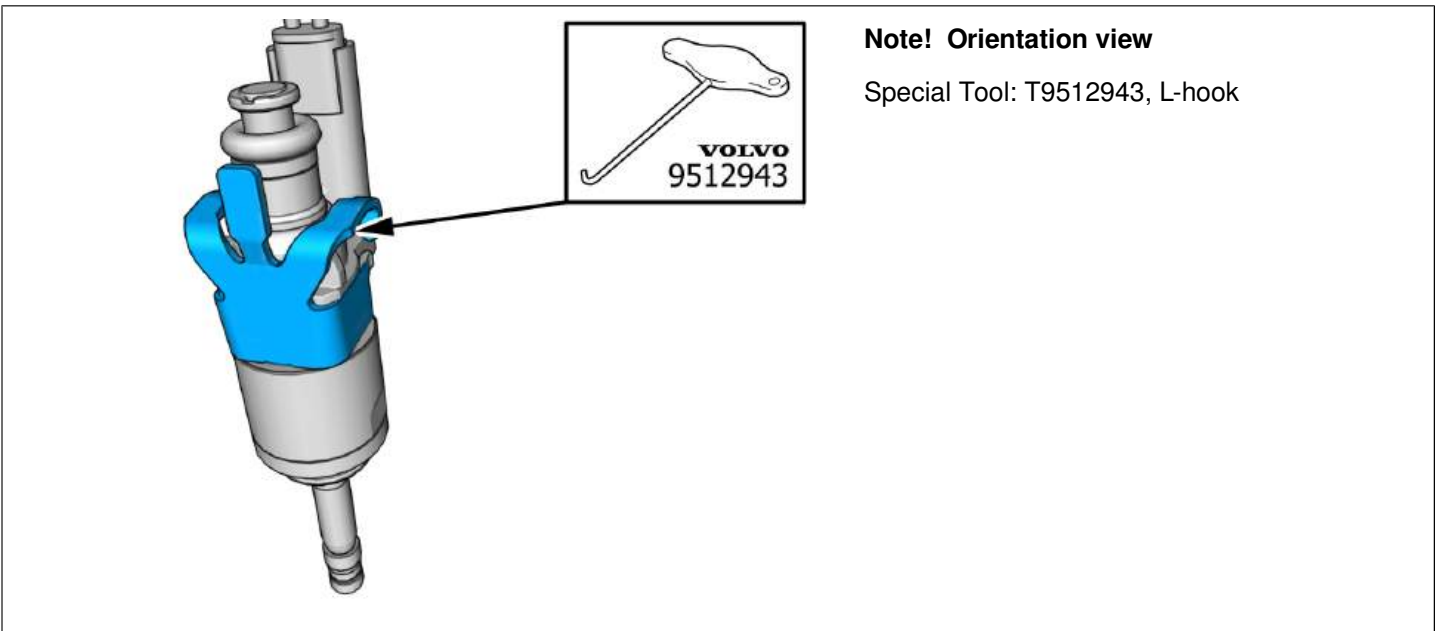

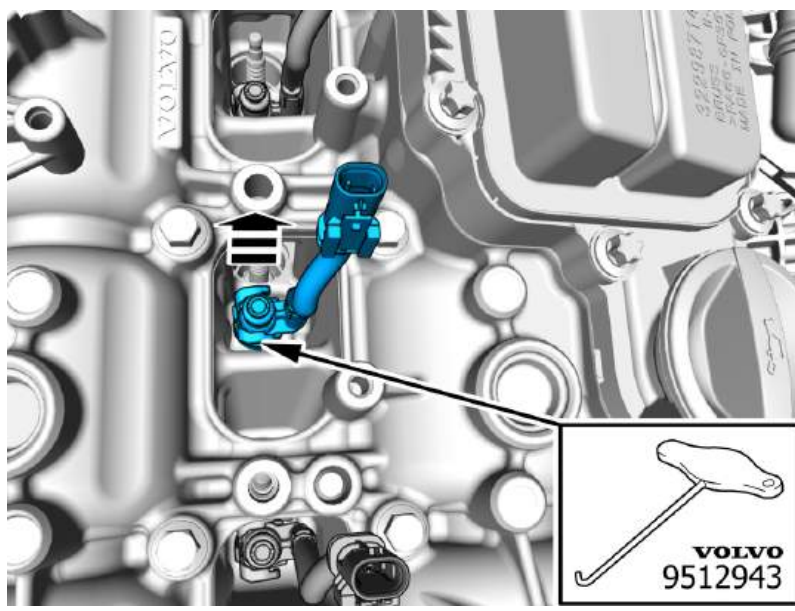

**Caution!** In order to avoid damage to the injectors, the part must be carefully pulled straight up.

**Caution!** Be extra careful when removing or installing this component.

Remove the marked part.

Special Tool: T9512943, L-hook

Replace injector seal , refer to:  
 Removal, replacement and installation  
 2 - Engine with mountings and equipment  
 23 - Fuel system  
 237 - injector and delivery pipe

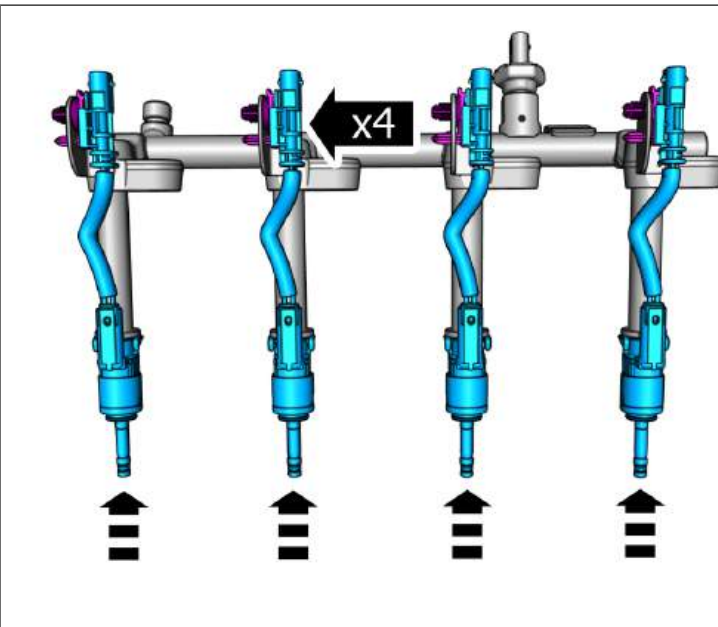

**Caution!** Be extra careful when removing or installing this component.

Install the marked components.

## Extra information

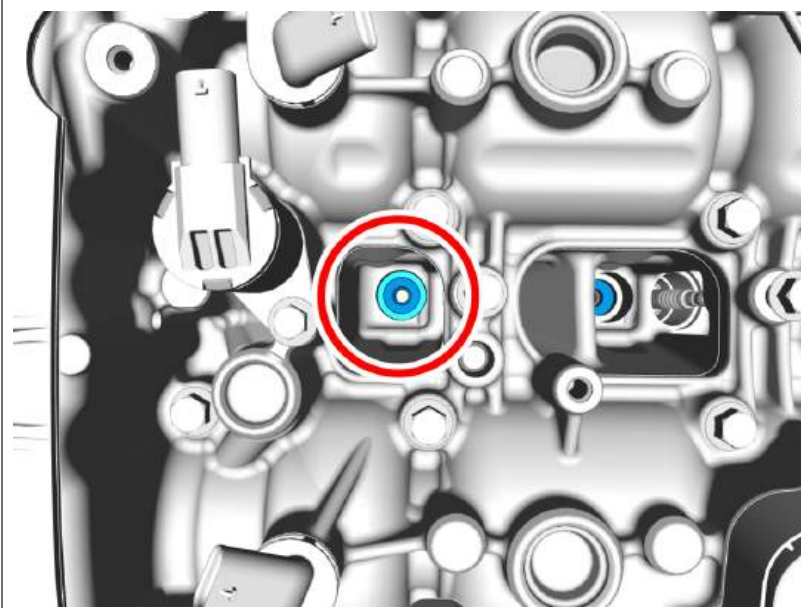

**Caution!** Make sure that the mating faces are clean and free of foreign material.

**Caution!** Clean carefully, using compressed air.

Special Tool: T9997505, Cleaning tool



Remove the Special Tool.

Applies to reassembly of the same component

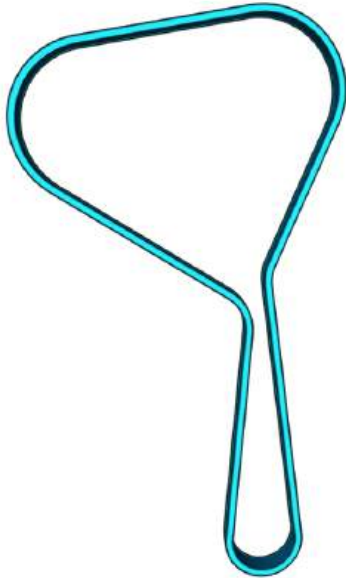

**Note!** The component can be reused unless it has been subjected to abnormal mechanical stress, damage or oil contamination.



**Caution!** The part is to be reused.

**Caution! The part is to be reused.**



**Continue the removal following the steps below.**

Remove camshaft seal , refer to:  
Removal, replacement and installation  
2 - Engine with mountings and equipment  
21 - Engine  
215 - transmission

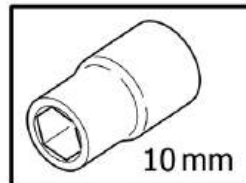

Loosen each bolt 2 turns at a time until all bolts are removed.  
Remove the marked part.

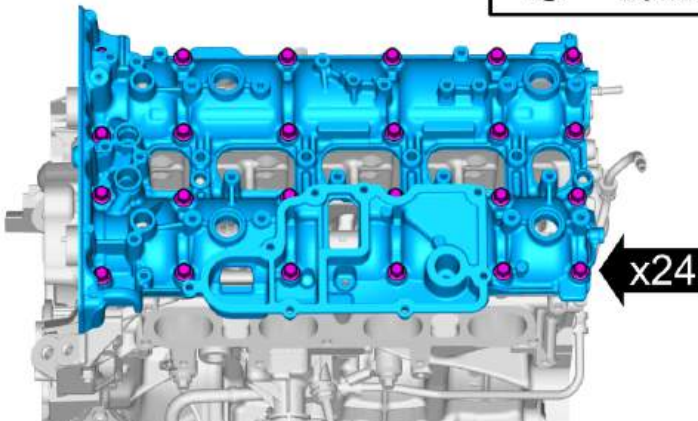

Vehicles early version

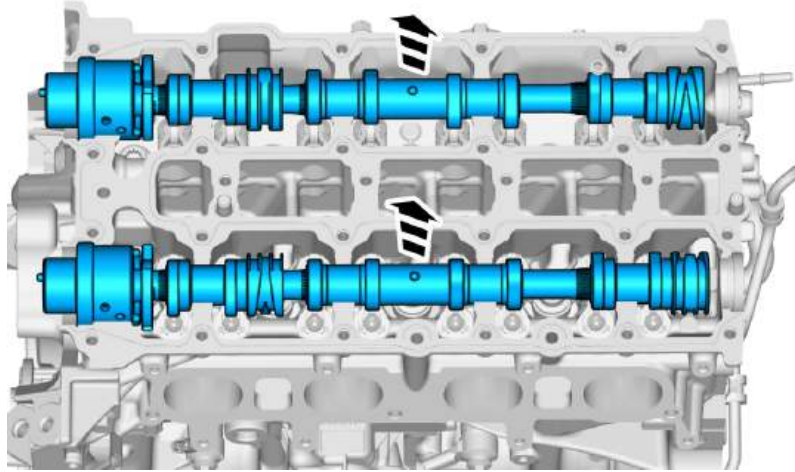

**Caution! Note the location of the component before removal.**

**Caution! Take extra care when handling the components.**

Remove the marked parts.

Vehicles late version

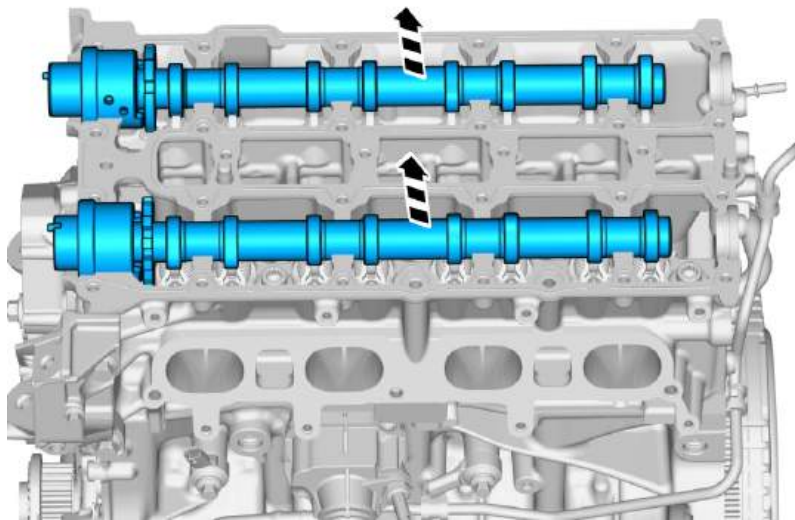

**Caution! Note the location of the component before removal.**

**Caution! Take extra care when handling the component.**

Remove the marked parts.

## Cleaning

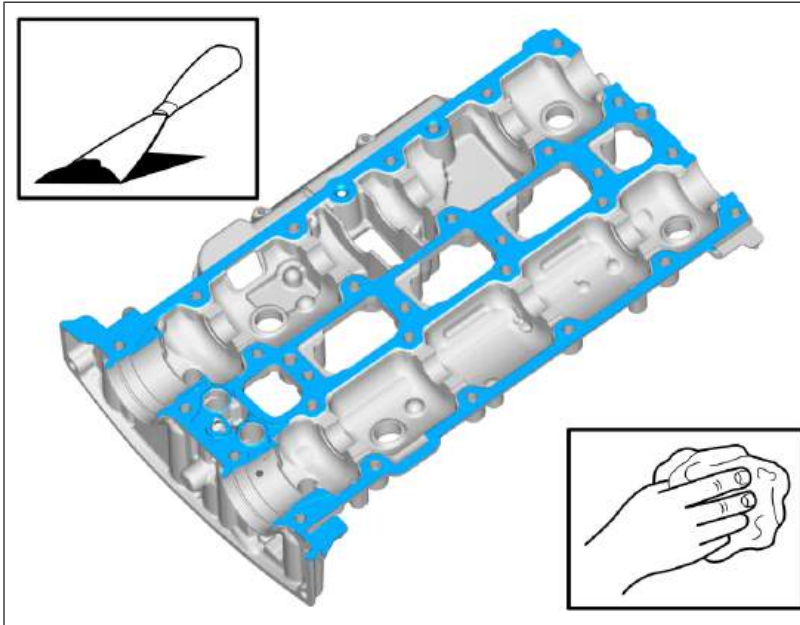

**Caution!** Take extra care not to damage the mating faces.

**Caution!** Make sure that the oil galleries are clean and free of foreign material.

**Note!** Make sure that the mating faces are clean and free of foreign material.

**Use:** Putty knife (plastic)

**Use:** Abrasive cloth

**Use:** Isopropanol ,

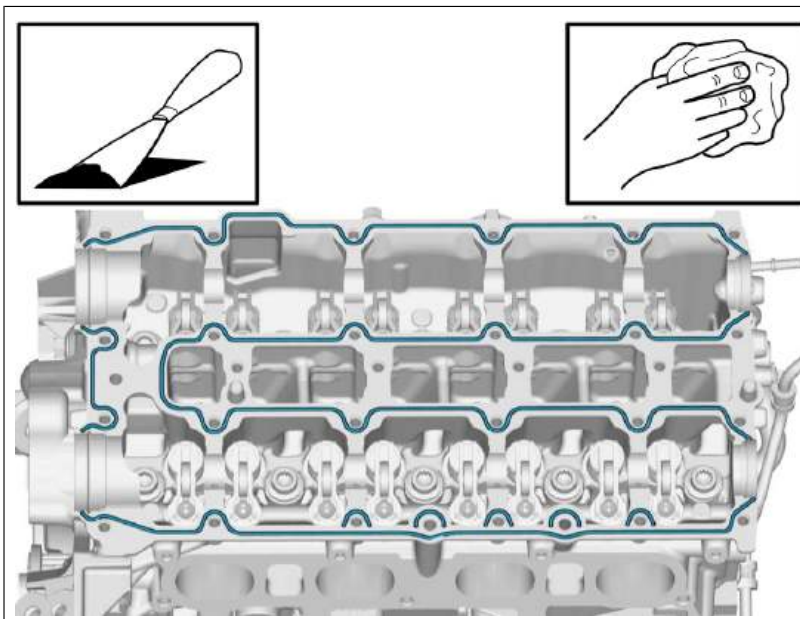

**Caution!** Take extra care not to damage the mating faces.

**Caution!** Make sure that the oil galleries are clean and free of foreign material.

**Note!** Make sure that the mating faces are clean and free of foreign material.

**Use:** Putty knife (plastic)

**Use:** Abrasive cloth

**Use:** Isopropanol ,

### Installation

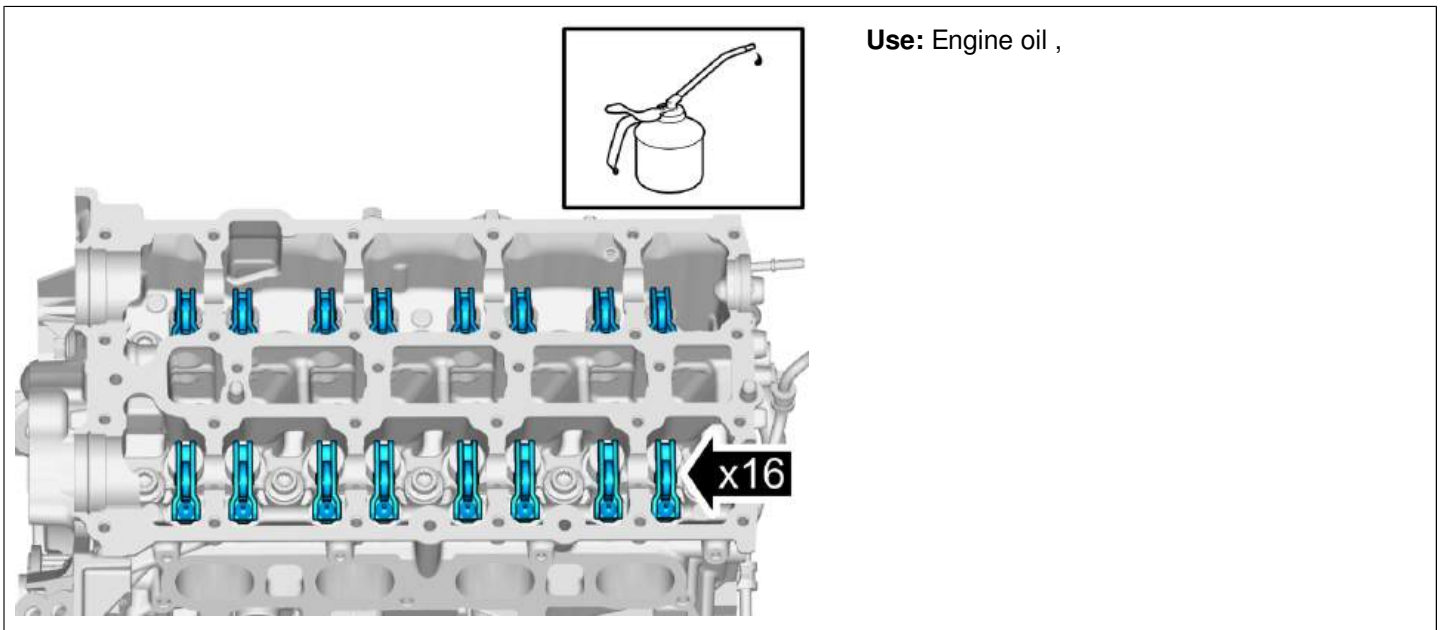
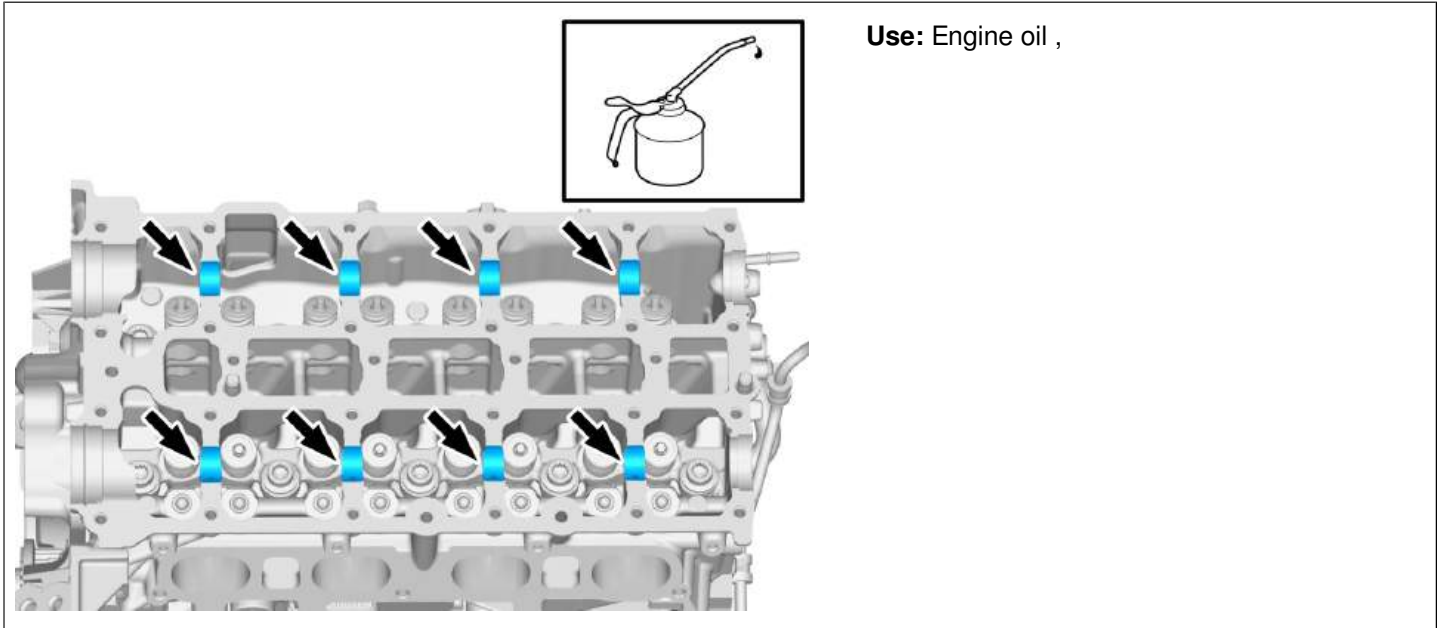

Vehicles early version

**Caution! Make sure that the components are positioned correctly.**

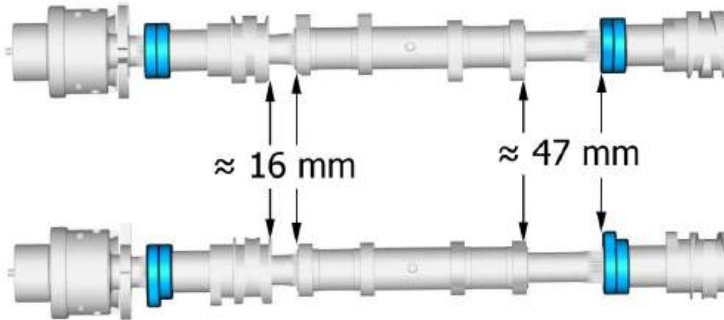

**Caution! Make sure that the components are positioned correctly.**

Install the marked components.

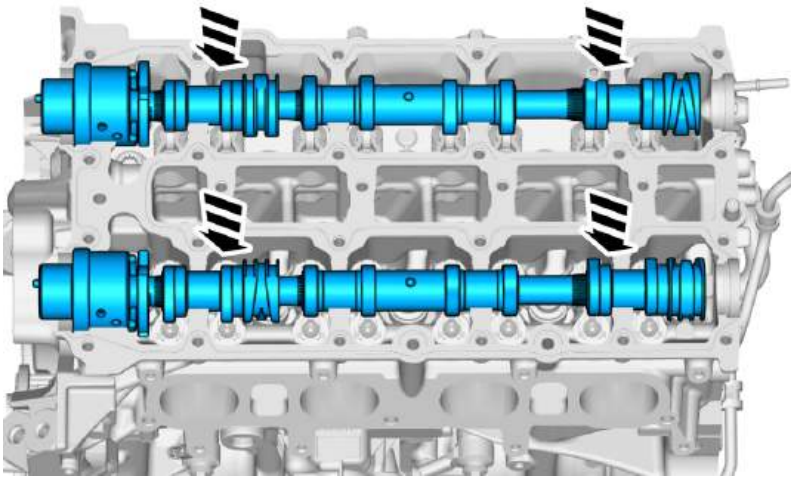

Vehicles late version

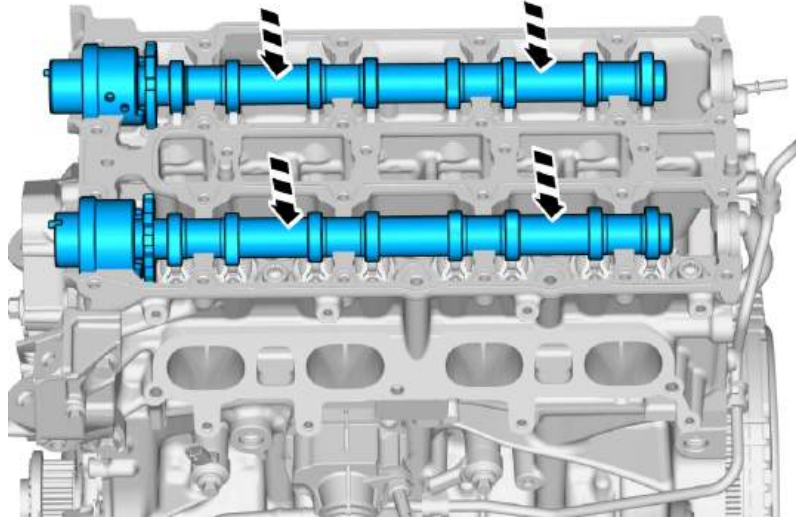

**Caution! Make sure that the components are positioned correctly.**

Install the marked components.

All vehicles

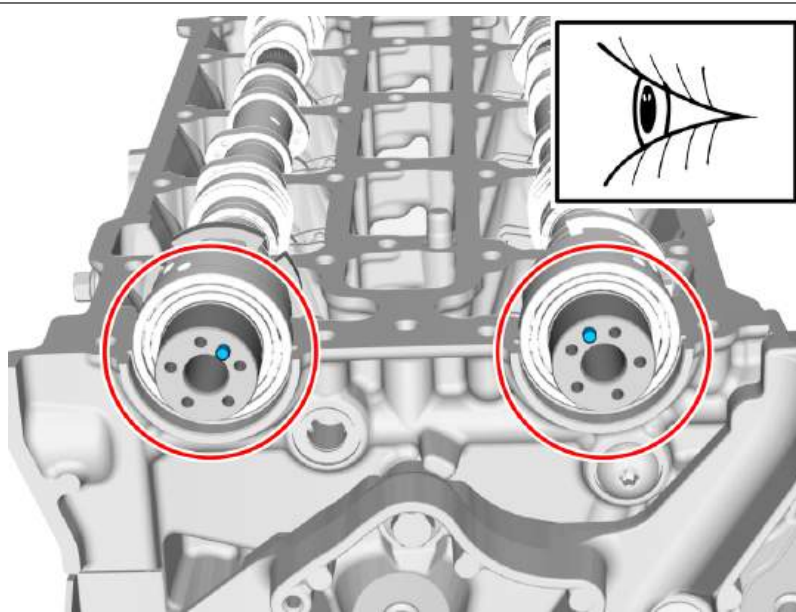

**Caution! Make sure that the components are positioned correctly.**

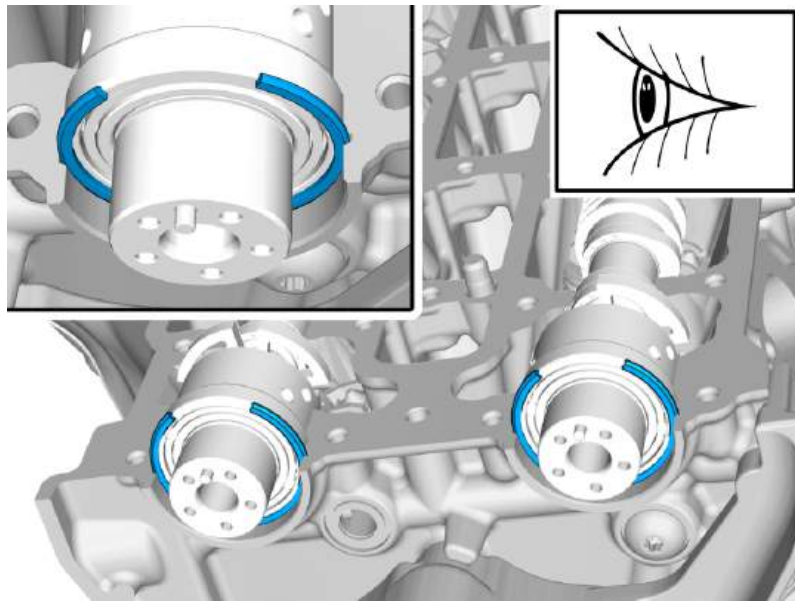

**Caution! Make sure that the components are positioned correctly.**

Install the marked components.

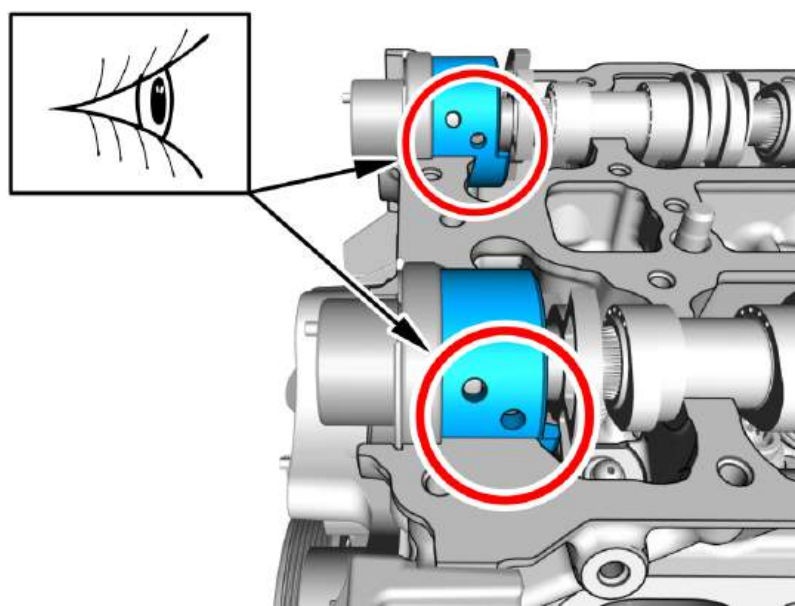

**Caution! Make sure that the components are positioned correctly.**

All vehicles

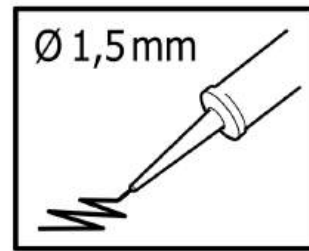
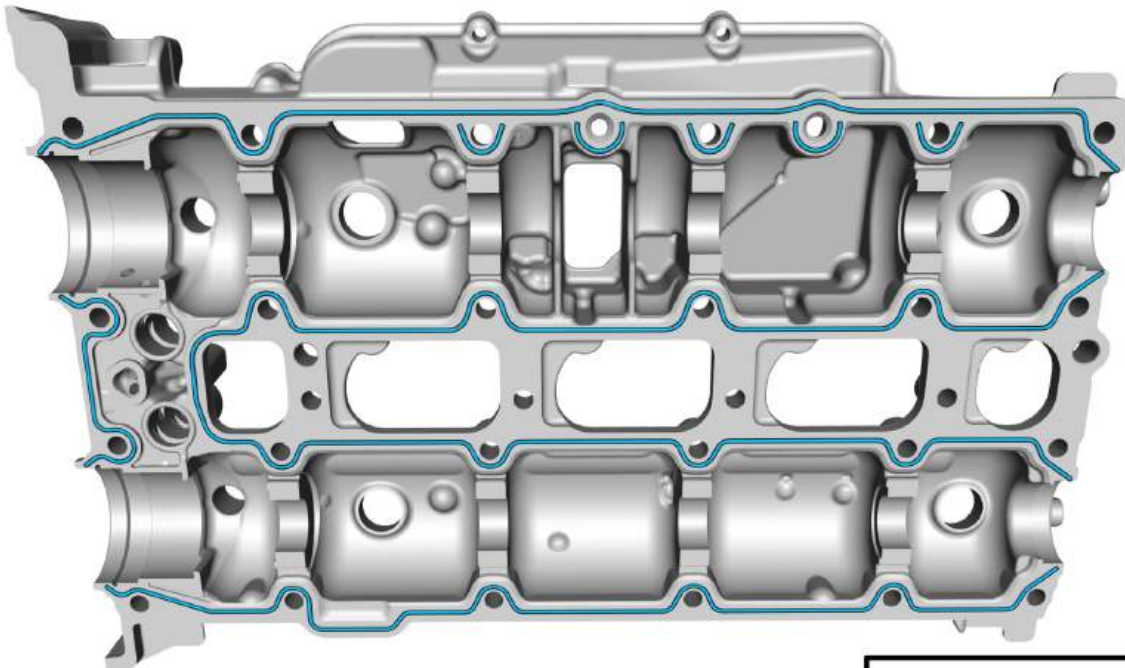

**Note!** The component must be installed within 5 minutes of applying the sealant.

**Use:** Chemical gasket , 1161771

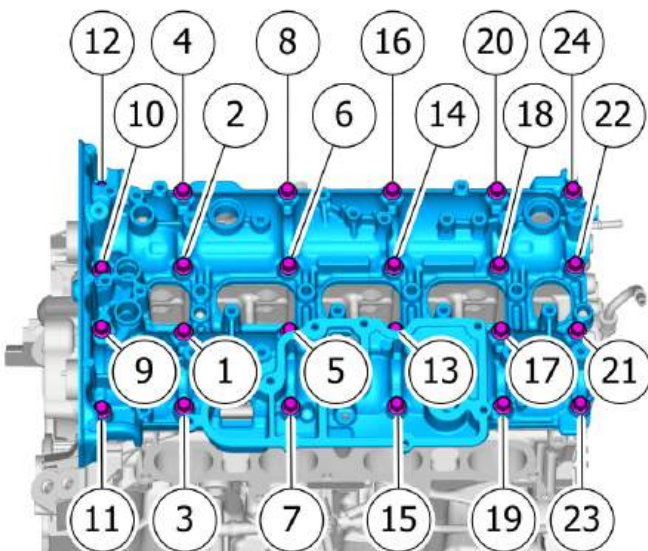

**Caution!** Make sure that equal pressure is applied to the full length of the component.

**Note!** Make sure to follow the sequence indicated.

Install the marked component.  
Install the screws.  
Tighten each bolt 2 turns at a time.

**Torque:**  
M7 , 17 Nm

To install, reverse the removal procedure.

**Check**

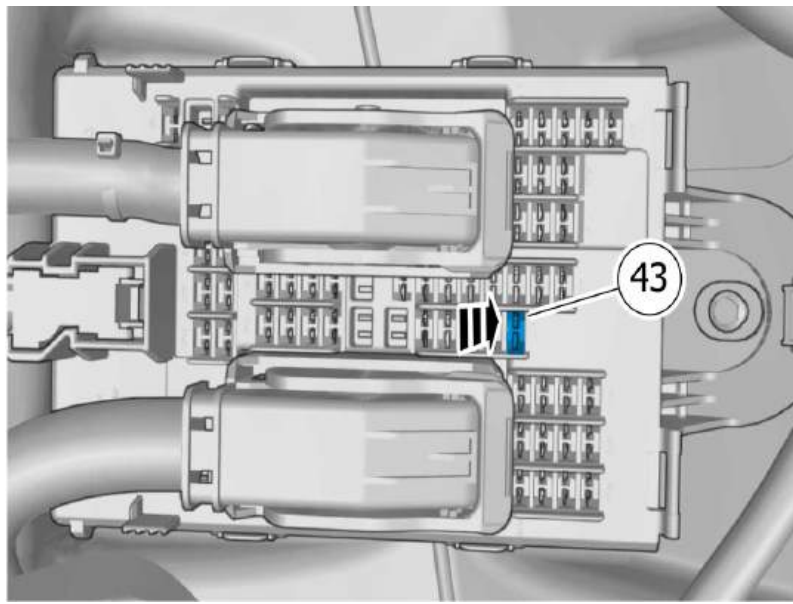

Reinstall the fuse.  
Start the engine.

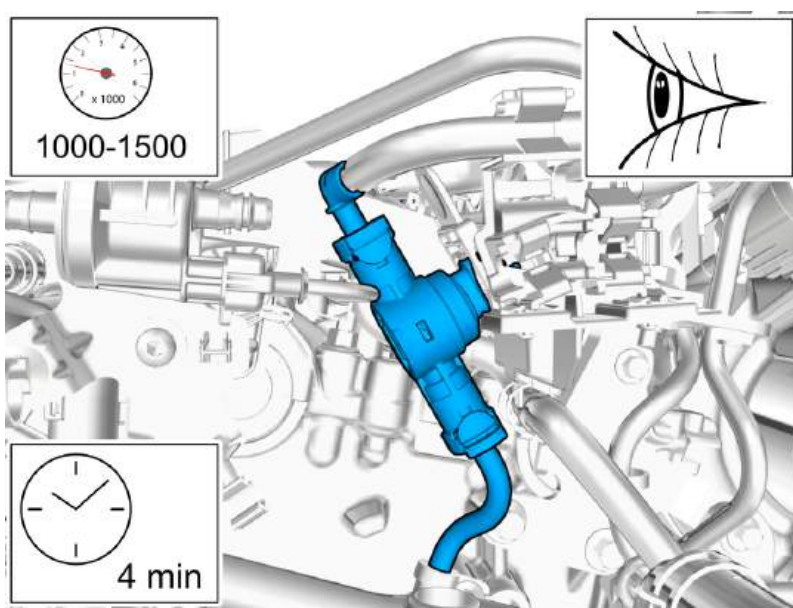

**Warning!** Make sure that there are no leaks.

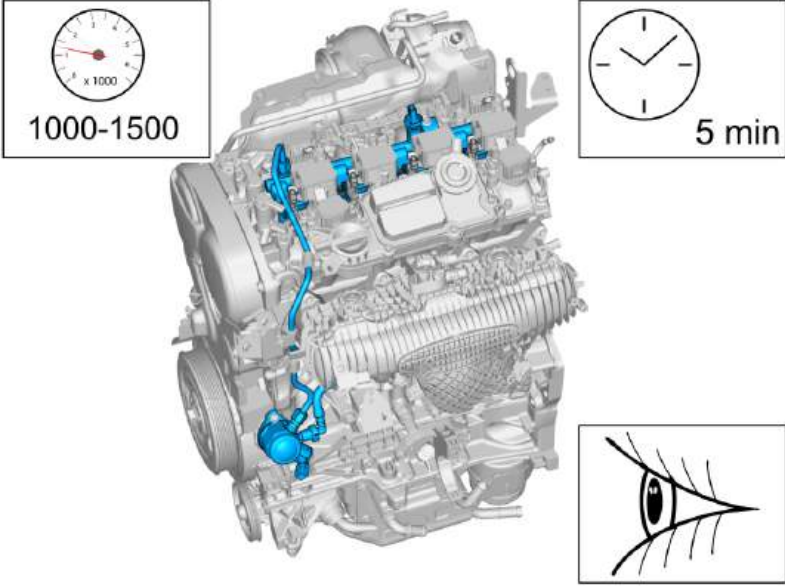

**Warning!** Make sure that there are no leaks.

The diagram shows a 3D cutaway view of an engine with blue hoses. To the left is a tachometer icon with a needle pointing to 1000-1500 RPM (x 1000). To the right is a clock icon labeled '5 min'. Below the engine is an icon of an eye, indicating a safety warning.

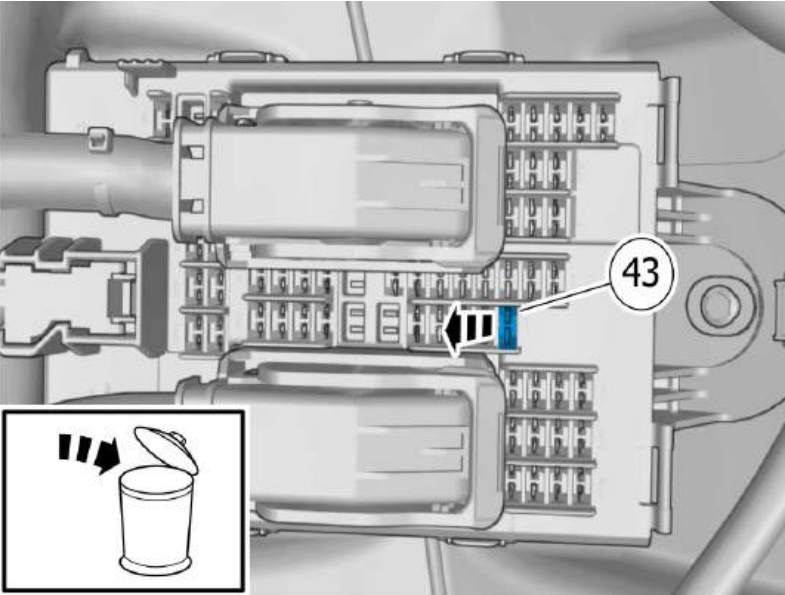

Switch off the engine.  
Discard of the previously installed fuse and install a new one.

The diagram shows a fuse box with a callout '43' pointing to a specific fuse. An inset icon shows a fuse being discarded into a trash can.