



Service Bulletin

Bulletin No.: 24-NA-166

Date: May, 2025

TECHNICAL

Subject: DTC C1171 C1172 C1173 C1174 Tire Pressure Monitor Sensor Unable to Relearn Ethernet Cable Overlay for TCP OnStar Module

This Service Bulletin replaces PIT6188E. Please discard all versions of PIT6188.

Brand:	Model:	Model Year:		VIN:		Engine:	Transmission :
		from	to	from	to		
Buick	Enclave	2025	2025				
Chevrolet	Traverse	2024	2025			LK0	
GMC	Acadia	2024	2025				

Involved Region or Country	North America, Middle East
Condition	<p>Some customers may comment on a Tire Pressure lamp illuminated and/or message on the dash. The dealer may also not be able to perform the tire pressure learn for one or both front tires.</p> <p>Note: If only the rear Tire Pressure Monitors are setting, then it is not related to this issue.</p> <p>Technician may find one or more of the following DTCs: DTCs C1171, C1172, C1172, and/or C1174.</p> <p>Important: This can cause fob related issues when accompanied by one or more of the DTCs listed above. If the customer is having intermittent fob issues and setting TPM codes, it is possible the new overlay in this procedure will resolve the fob concerns too.</p>
Cause	The causes of the condition may be interference from OnStar module due to an issue grounding from the X7 connector on the Ethernet cable. This issue can also be intermittent.
Correction	Replace Ethernet cable with overlay. Refer to the Service Procedure below.

Service Procedure

Important: Service agents must comply with all International, Federal, State, Provincial, and/or Local laws applicable to the activities it performs under this bulletin, including but not limited to handling, deploying, preparing, classifying, packaging, marking, labeling, and shipping dangerous goods. In the event of a conflict between the procedures set forth in this bulletin and the laws that apply to your dealership, you must follow those applicable laws.

Important: This technical service bulletin (TSB) can only be completed by certified repair facilities who have met all specific training, tool and equipment requirements pertaining to the vehicle Brand and Model serviced. Repairs must be performed by a technician who has successfully completed the required training.

1. Once confirmed the TPM sensors cannot be learned, gain access to the rear headlining trim panel. DO NOT remove the headlining trim panel, only lower it to gain access Refer to Headlining Trim Panel Replacement in SI. Disconnect the X7 connector and attempt to learn the TPM sensors.

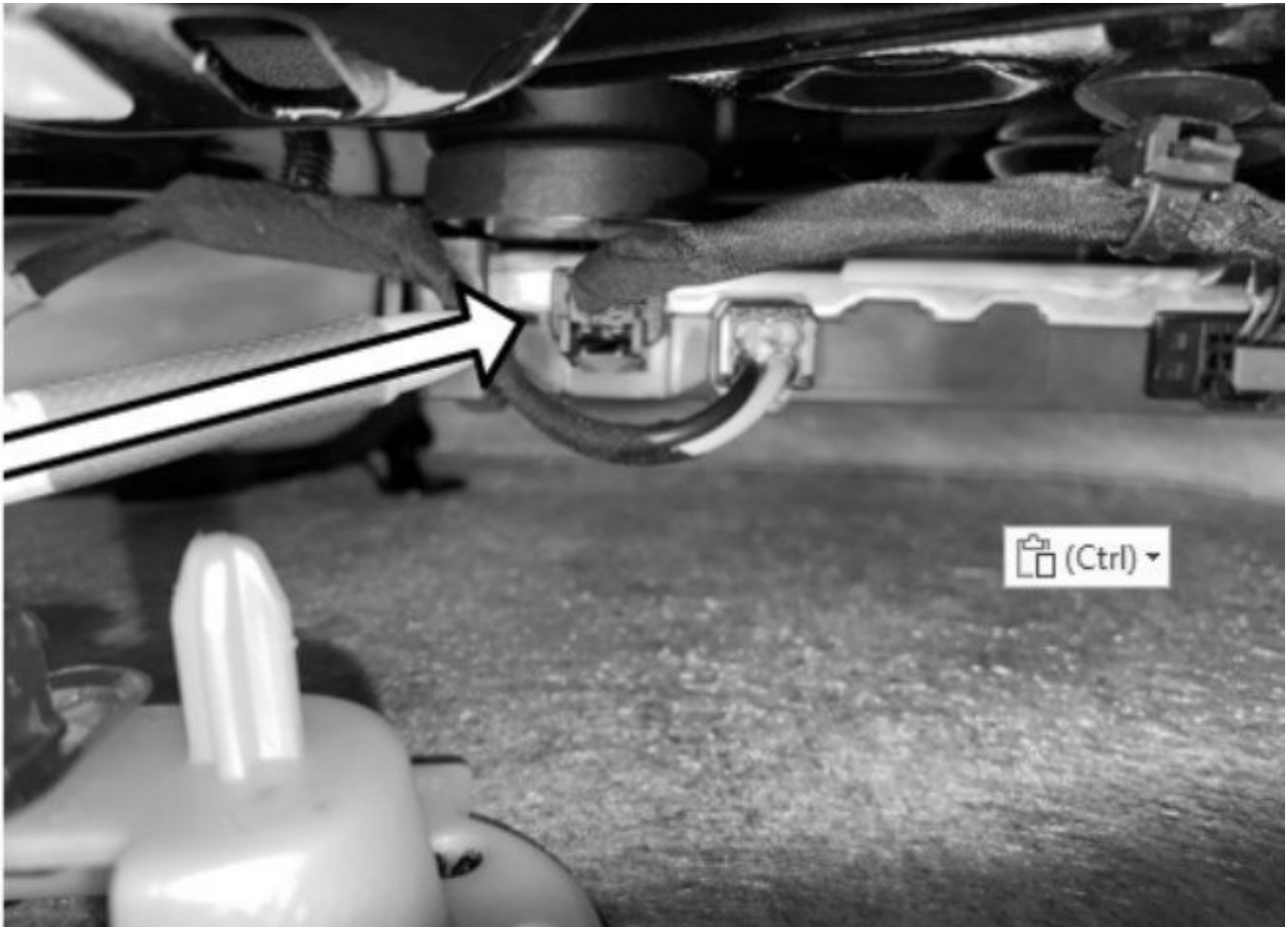

6720400

If the TPM sensors are able to learn, continue with Ethernet Cable replacement. Otherwise follow SI.

2. Transfer housing connectors.
3. Fold the 3rd row seats forward.
4. Remove the Rear Compartment Floor Stowage Compartment Divider. Refer to *Rear Compartment Floor Stowage Compartment Divider Replacement* in SI.
5. Remove the Right-Hand Front Side Door Sill Garnish Molding. Refer to *Front Side Door Sill Garnish Molding Replacement* in SI.
6. Remove the Right-Hand Rear Side Door Sill Garnish Molding. Refer to *Rear Side Door Sill Garnish Molding Replacement* in SI.
7. Loosen the Center Pillar Lower Trim Panel from the vehicle. Refer to *Center Pillar Lower Trim Panel Replacement* in SI.



6699007

8. Fold and raise up the Right-Hand Rear seat. **DO NOT REMOVE.**
9. Remove the Right-Hand Quarter Upper and Lower Rear Trim Panel. Refer *Quarter Lower Rear Trim Panel Replacement (Right Side)* in SI.
10. Loosen the Left-Hand Quarter Upper Trim Panel. Refer to *Quarter Upper Trim Panel Replacement* in SI.



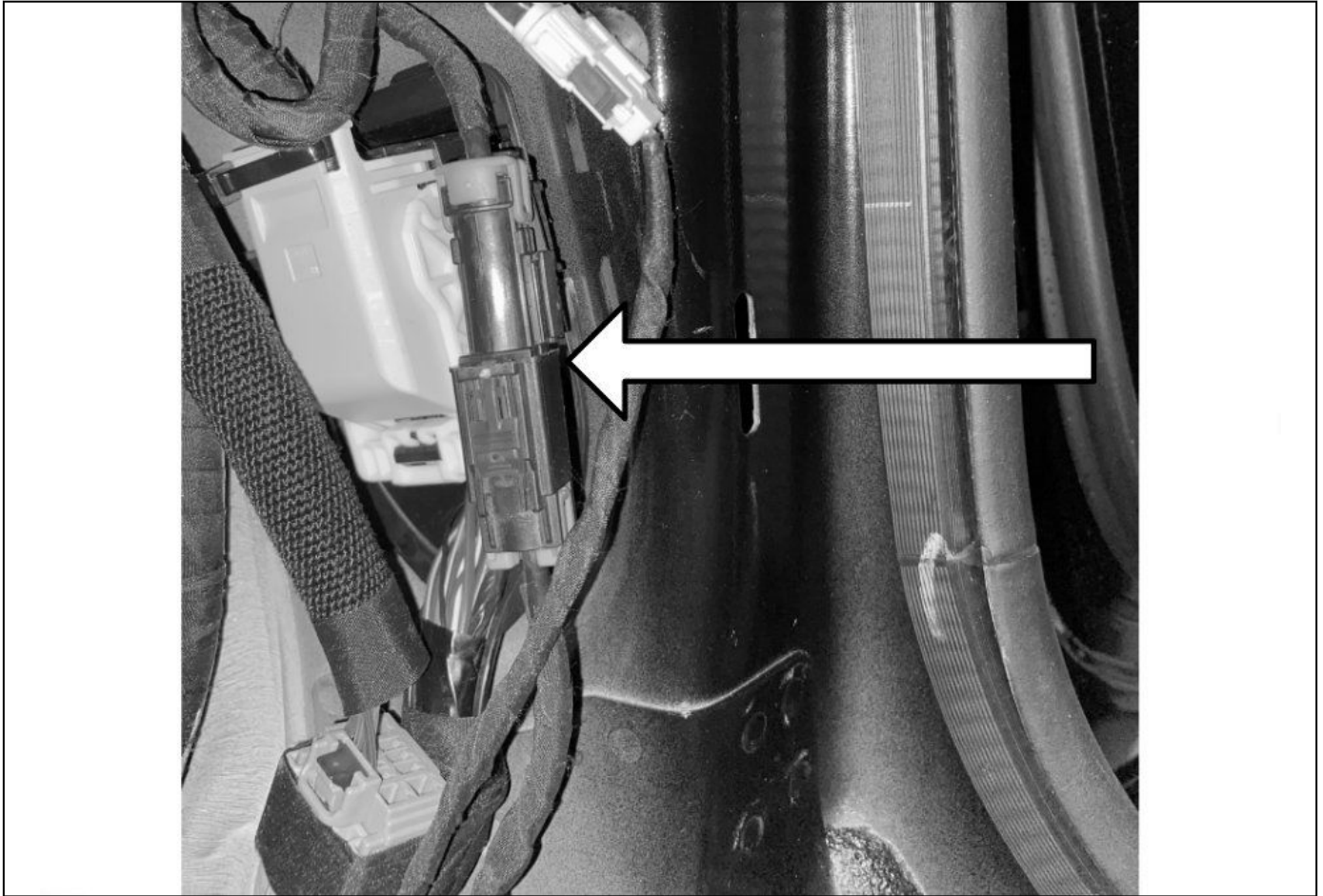

6699008

11. Locate the X205 Ethernet Cable in the Right-Hand Front Passenger Compartment and disconnect.

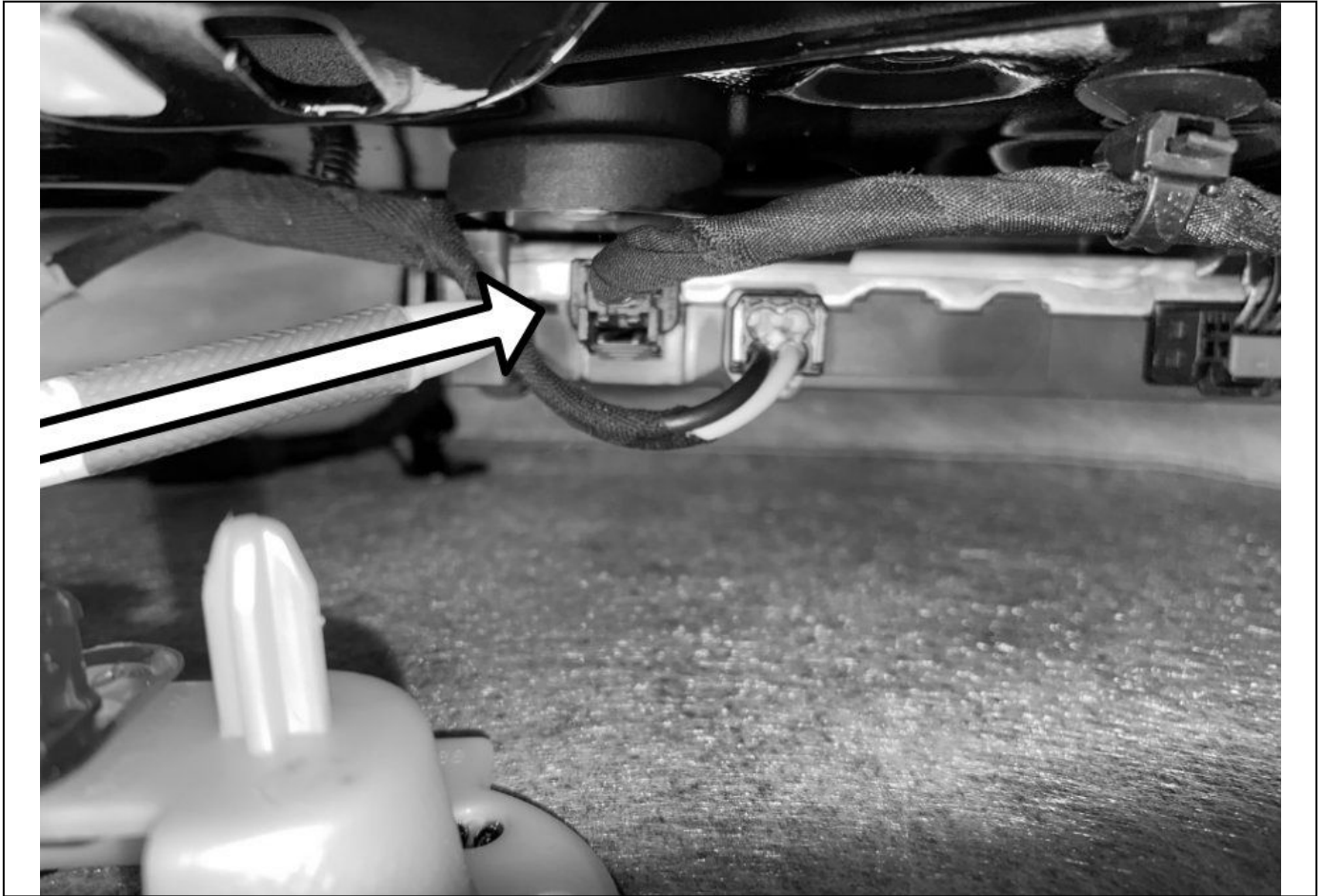

6699010

12. Locate the X7 Ethernet Cable at the Telematic Control Module and disconnect.

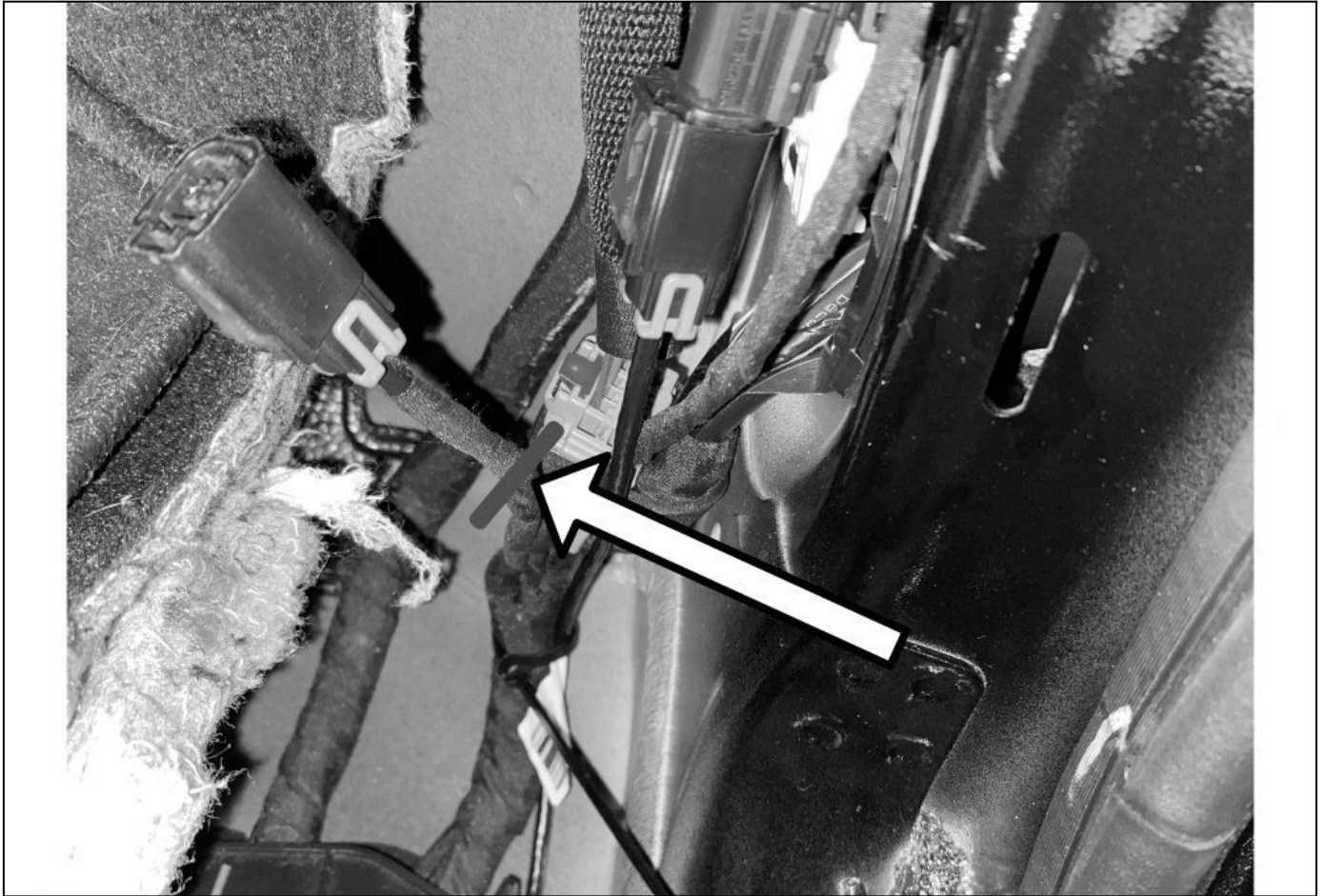



6699015

Caution: Use care to terminate the correct connector.

Note: The existing Ethernet cable is bundled with the body harness. The service ethernet cable will be routed next to the body harness. The terminals must be removed from the existing ethernet cables to ensure they are not used in future repairs.

13. Cut BOTH ends off the existing Ethernet Cable at X205 and X7 of the Telematic Control Module and wrap PVC Electrical tape around both ends of the cable to prevent future use. The unused cable can remain bundled with the body harness.

Important: Keep both ends and connectors. The housing will need to be transferred to the new cable.

14. Transfer both housings to the new cable. The new cable will come without the housings.

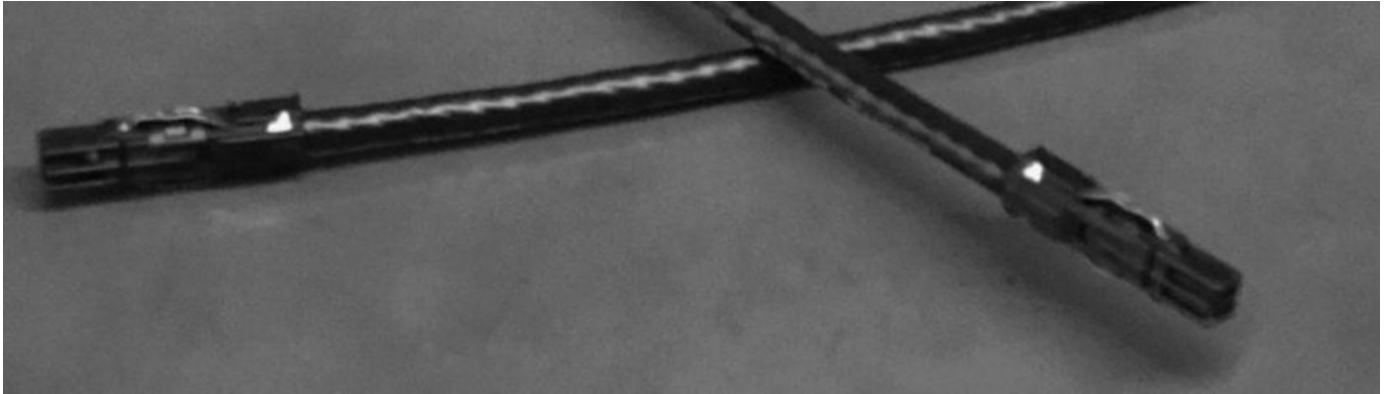

6720419

15. Transferring the X205 housing.

15.1. Remove the rear clip but releasing both clips from the outer housing and remove it.

Important: Save this clip for the new cable.



6720403

Empty housing shell. Circle in red is the 1 release tab. Arrow is showing the direction the tab needs to be pressed to release the cable, moving it away from the middle.

Note: Very minimal pressure is needed.

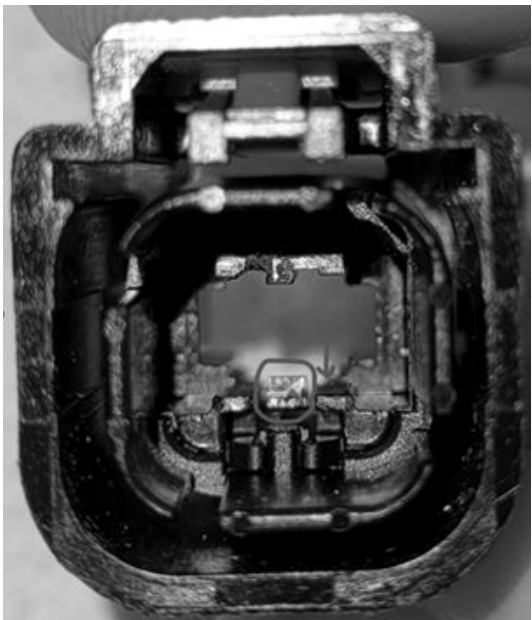

6720429

The X205 housing tab is very difficult to see with the cable installed.

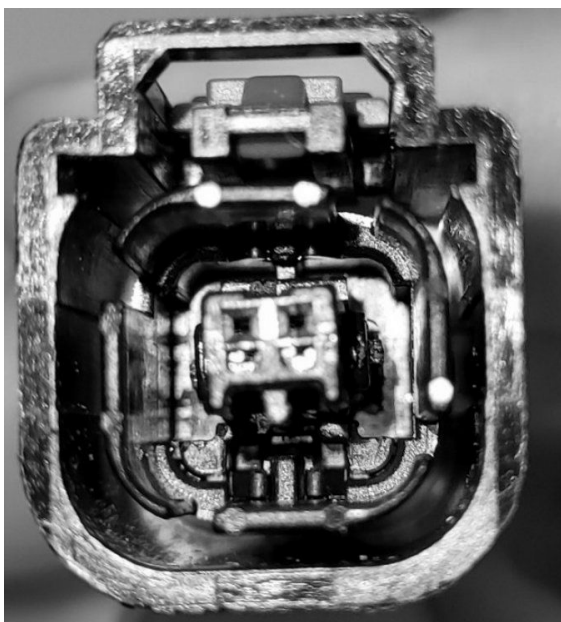

6720432

Following the middle ridge to the back, this is where the housing locks onto the cable.

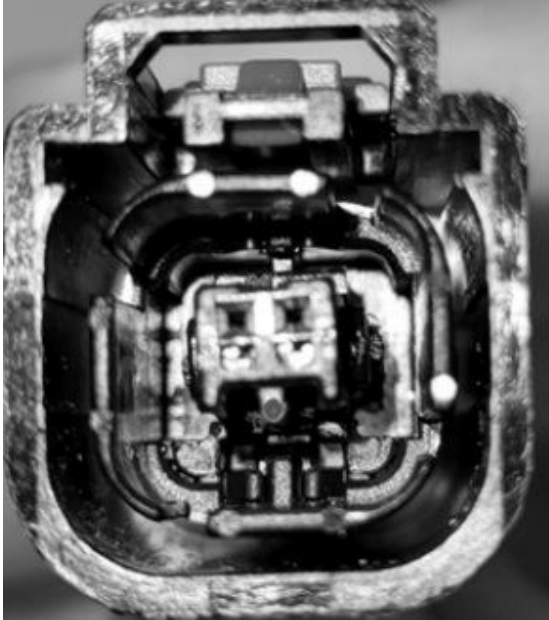

6720428



6720401

The best way to get to the release tab is to follow the cable's middle ridge the back (do not ride the wall of the housing or you will miss it, use the cable's middle ridge to guide you). Using light pressure, press away from the center towards the housing to release. Make sure to apply light pulling pressure to the back of the cable so it can release while depressing the tab.

Note: Slide off the seal and save it for the new cable.

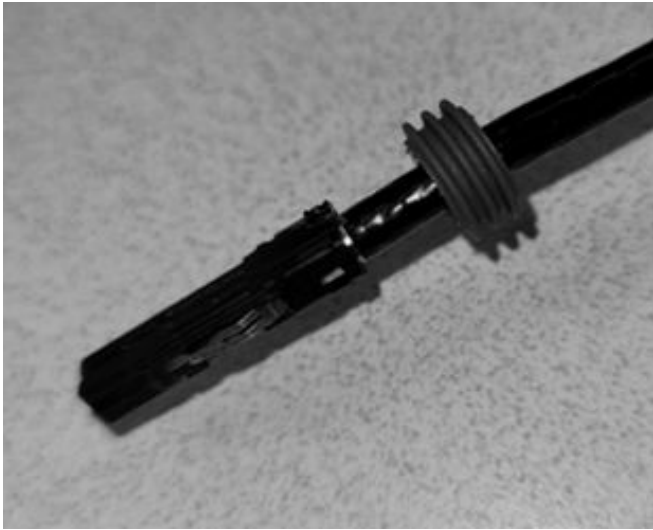

6720420

16. Transferring the X205 housing.

Here is the empty housing shell. Circle in red is the 1 release tab. The arrow is showing the direction the tab needs to be pressed to release the cable. Moving it away from the middle.

Note: Very minimal pressure is needed.

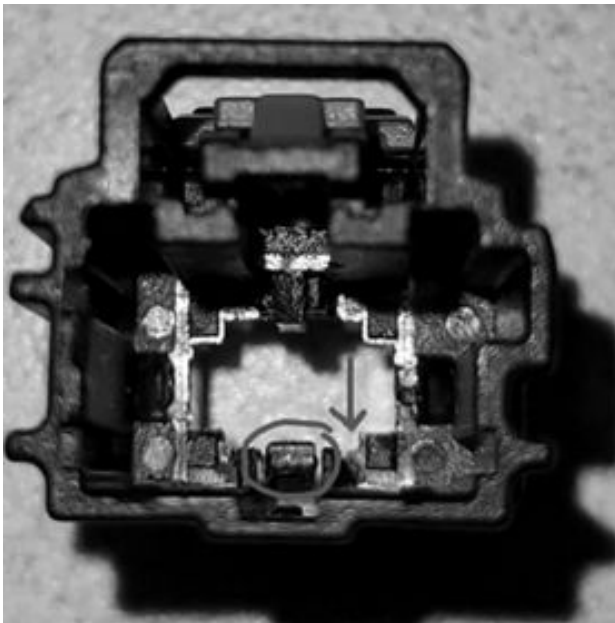

6720422

The X7 housing tab is very difficult to see with the cable installed.

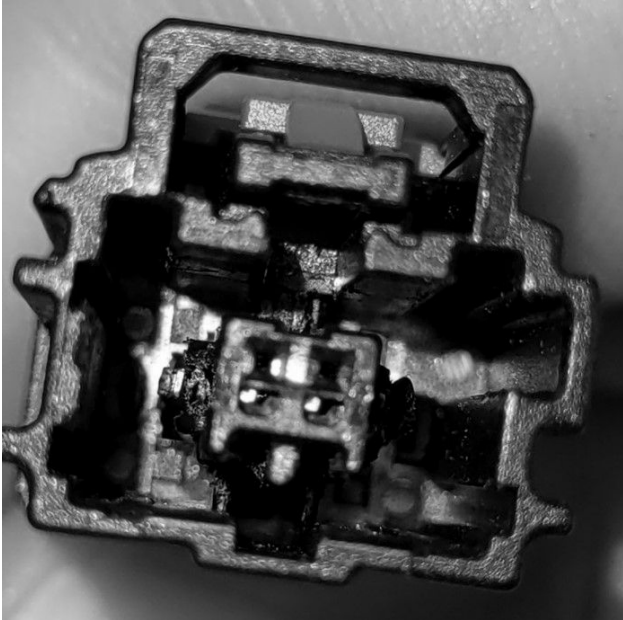

6720426

Following the middle ridge to the back, this is where the housing locks onto the cable.

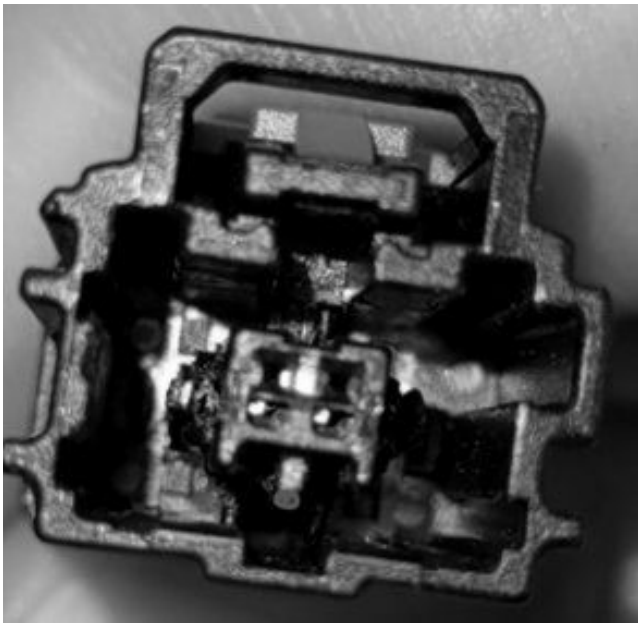

6720425



6720417

The best way to get to the release tab is to follow the cable's middle ridge the back (do not ride the wall of the housing or you will miss it, use the cable's middle ridge to guide you.) Using light pressure, press away from the center towards the housing to release. Make sure to apply light pulling pressure to the back of the cable so it can release while depressing the tab.

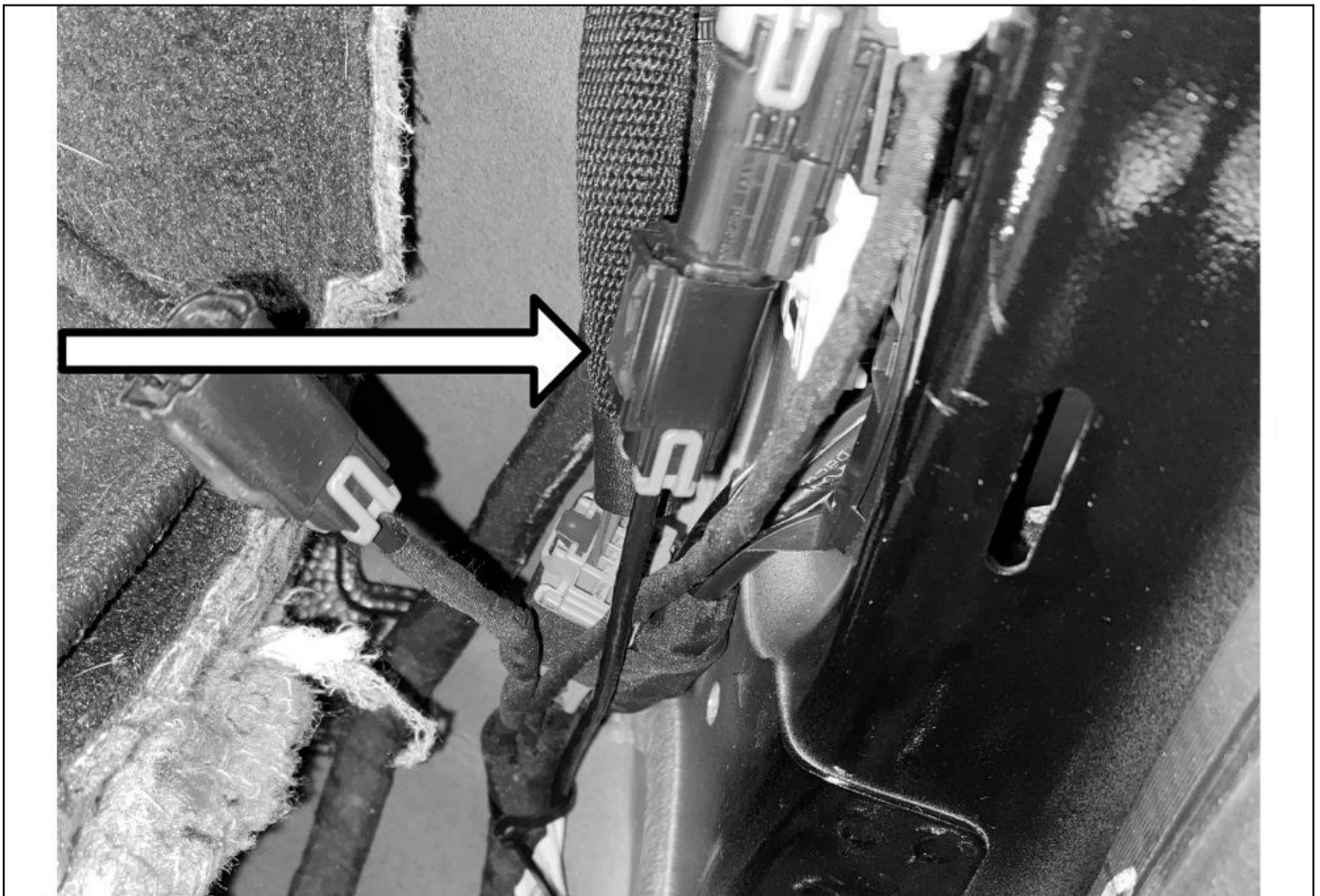

6706059

17. Connect the Replacement Ethernet Cable the connector at X205.

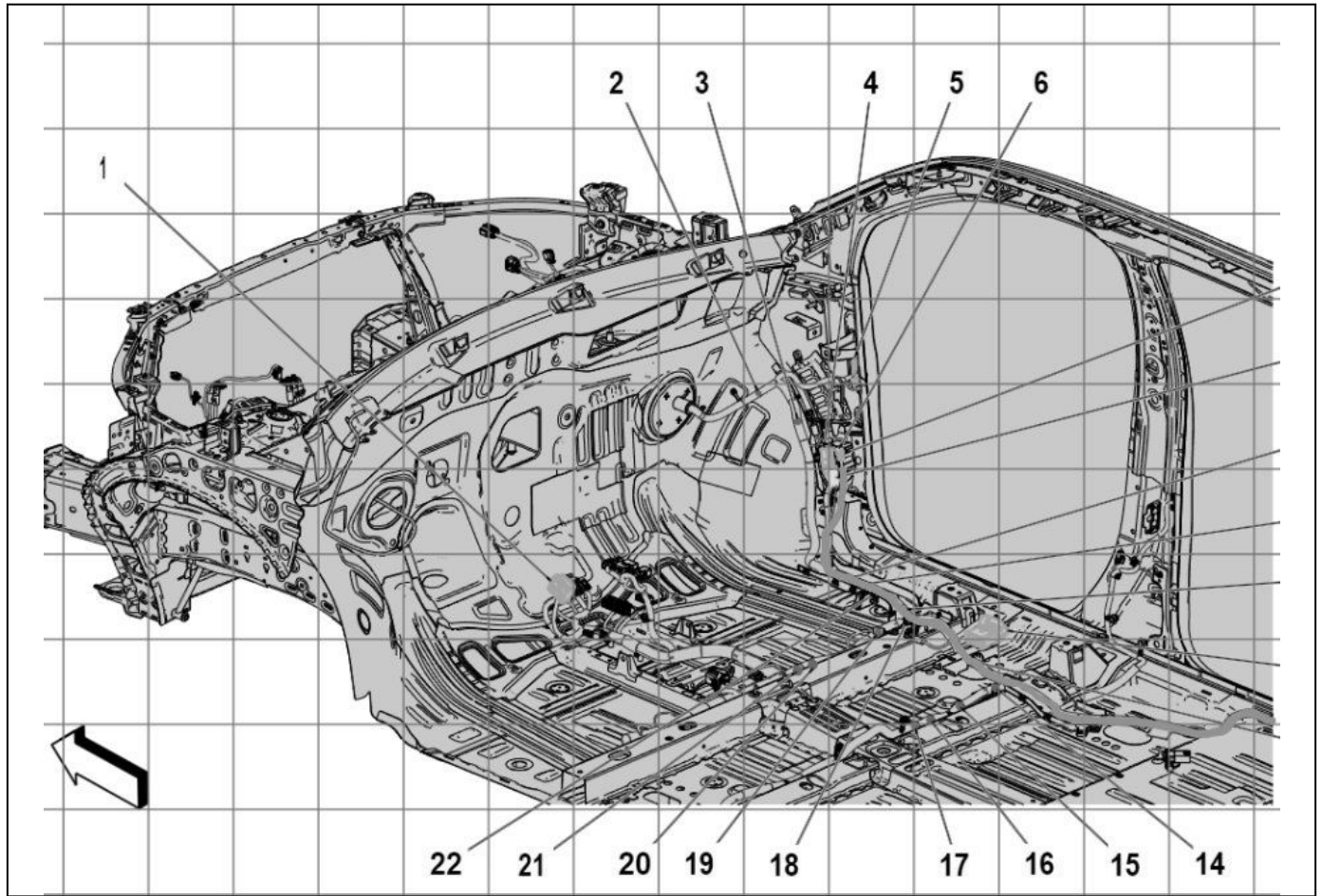

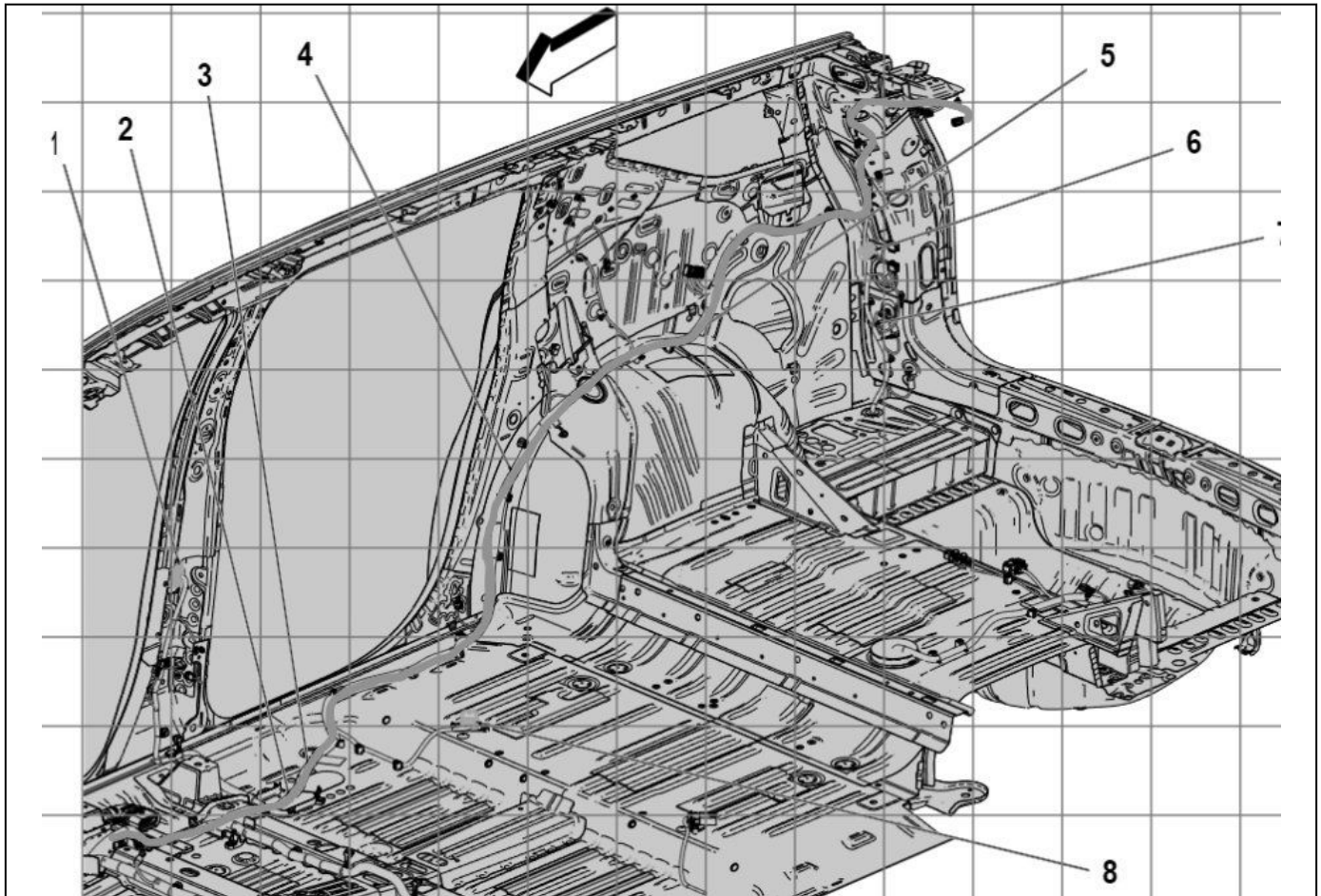

6706066

Note: Replacement Ethernet Cable routing shown in Green.

Important: Use extreme care when handling the new service ethernet cables. Avoid kinks, sharp bends, pinch points, and excessive wire tie tightness.

18. Begin to route the new Service cable starting at X205 and following the Body Wiring Harness running back towards the Telematic Control Module. Use the diagrams above to reference cable routing.

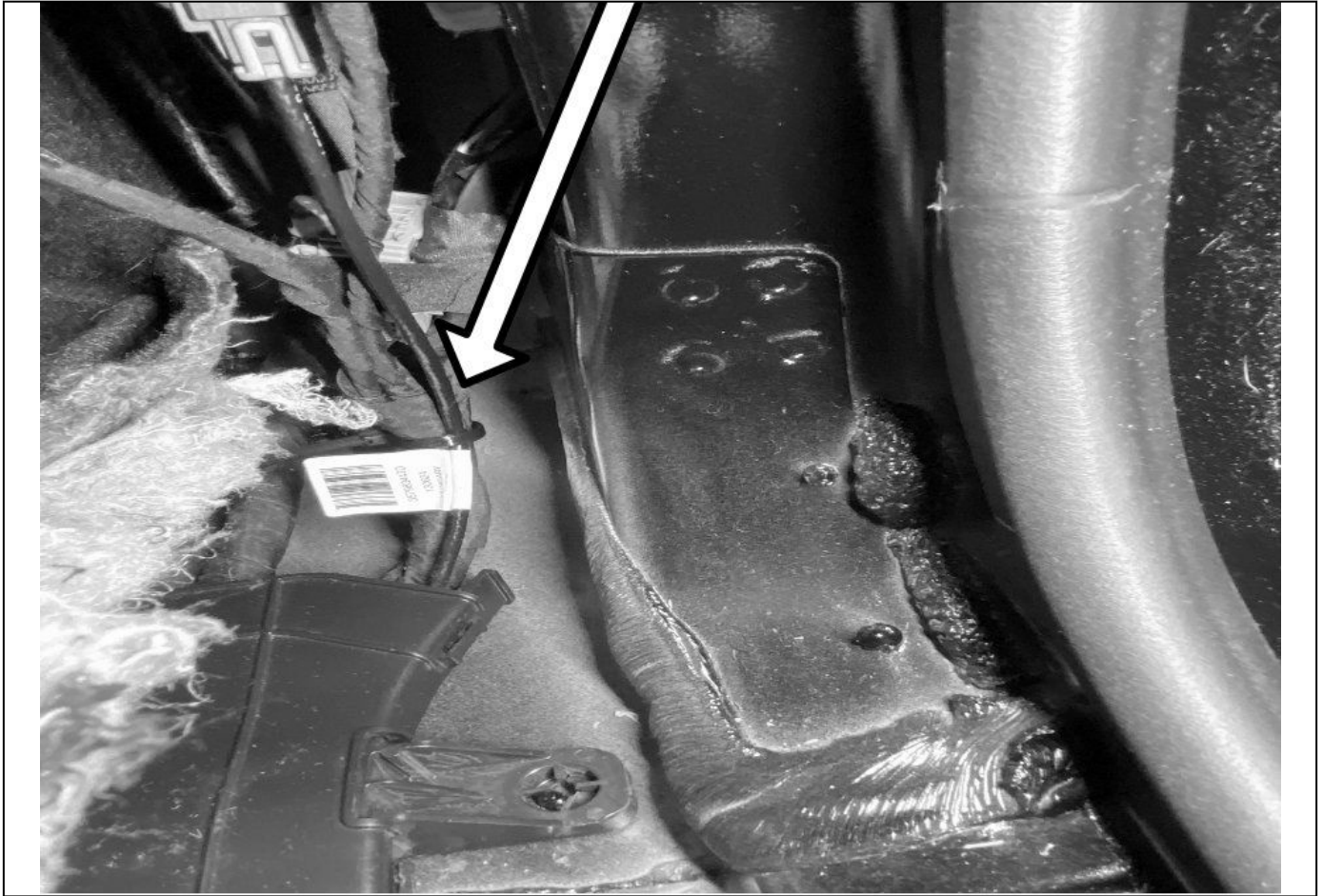

6706076



6706090

19. Run the replacement Ethernet Cable through the body wiring harness clamshell and underneath the Front Passenger Seat.



6706097

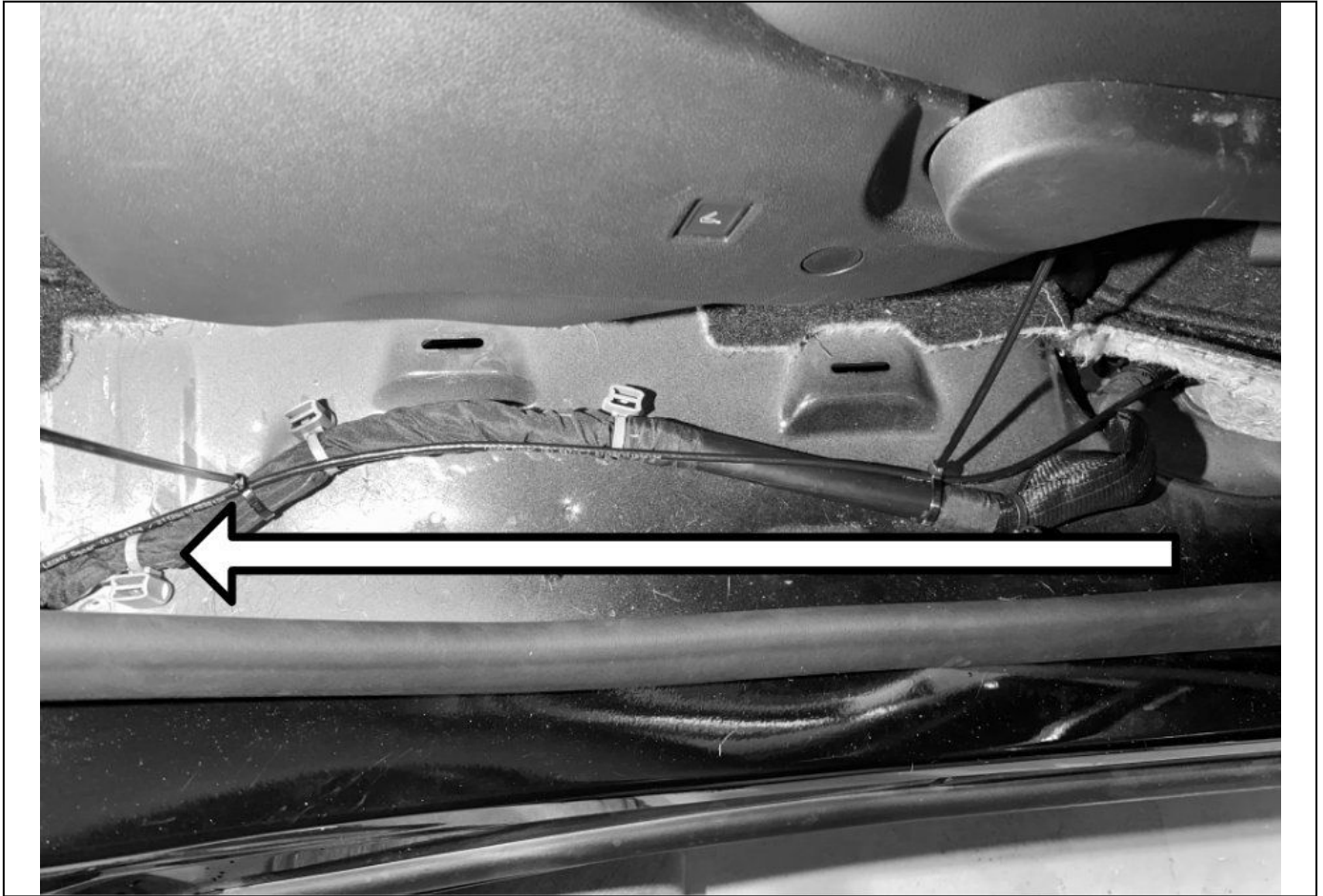

6706101

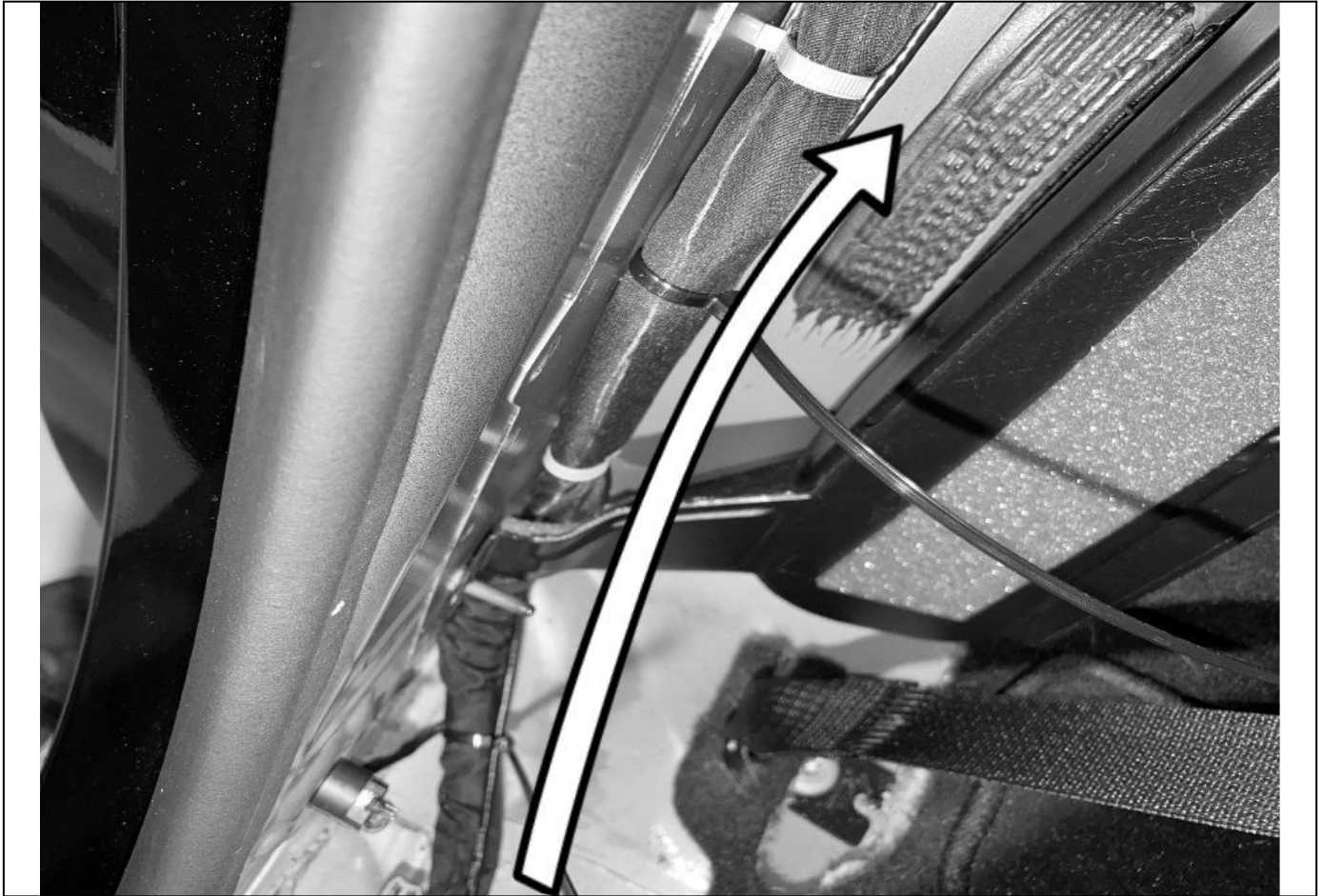

6706111

20. Continue to route the replacement Ethernet Cable alongside the Body Wiring Harness in the rear passenger compartment and up the C-Pillar.

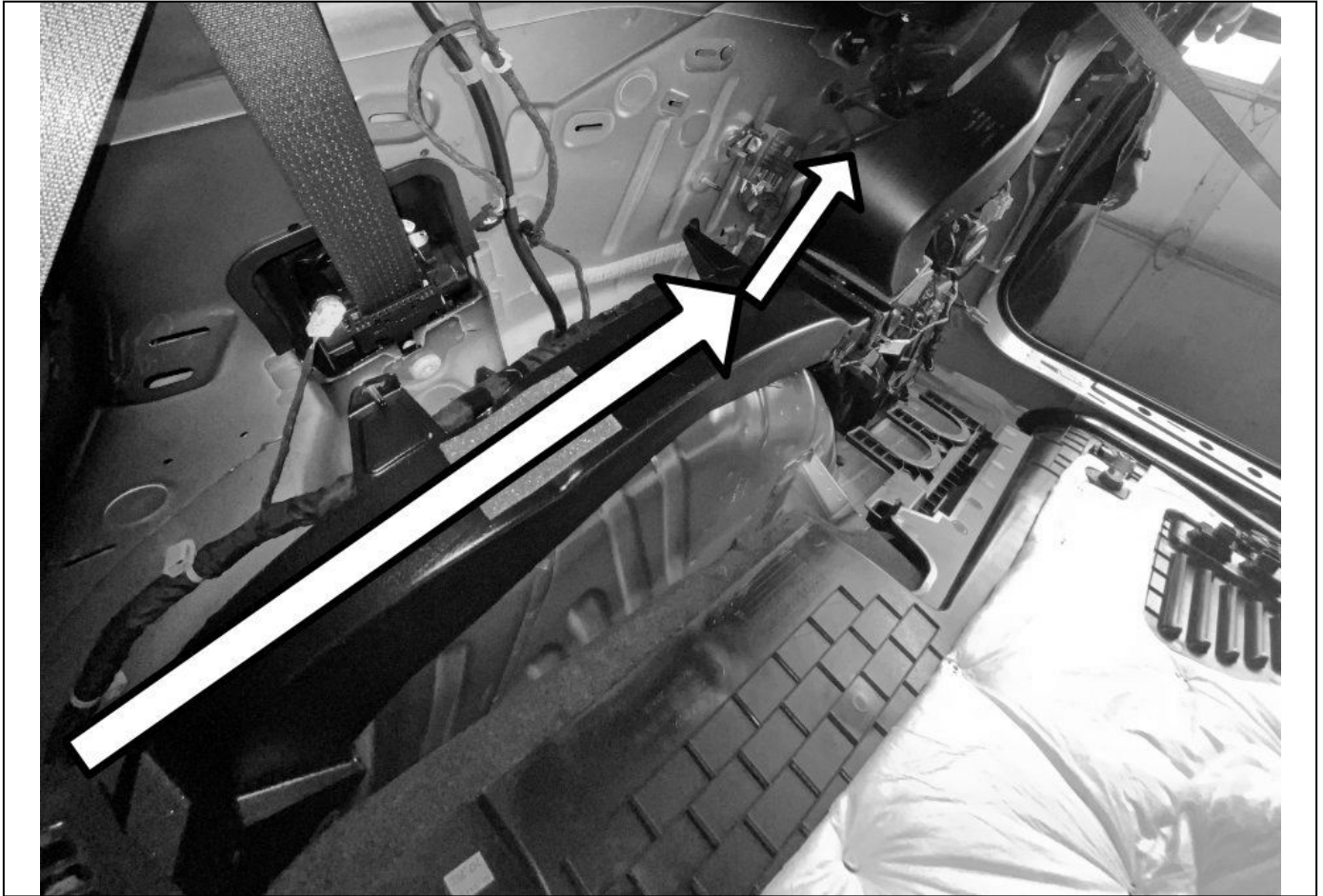

6706120

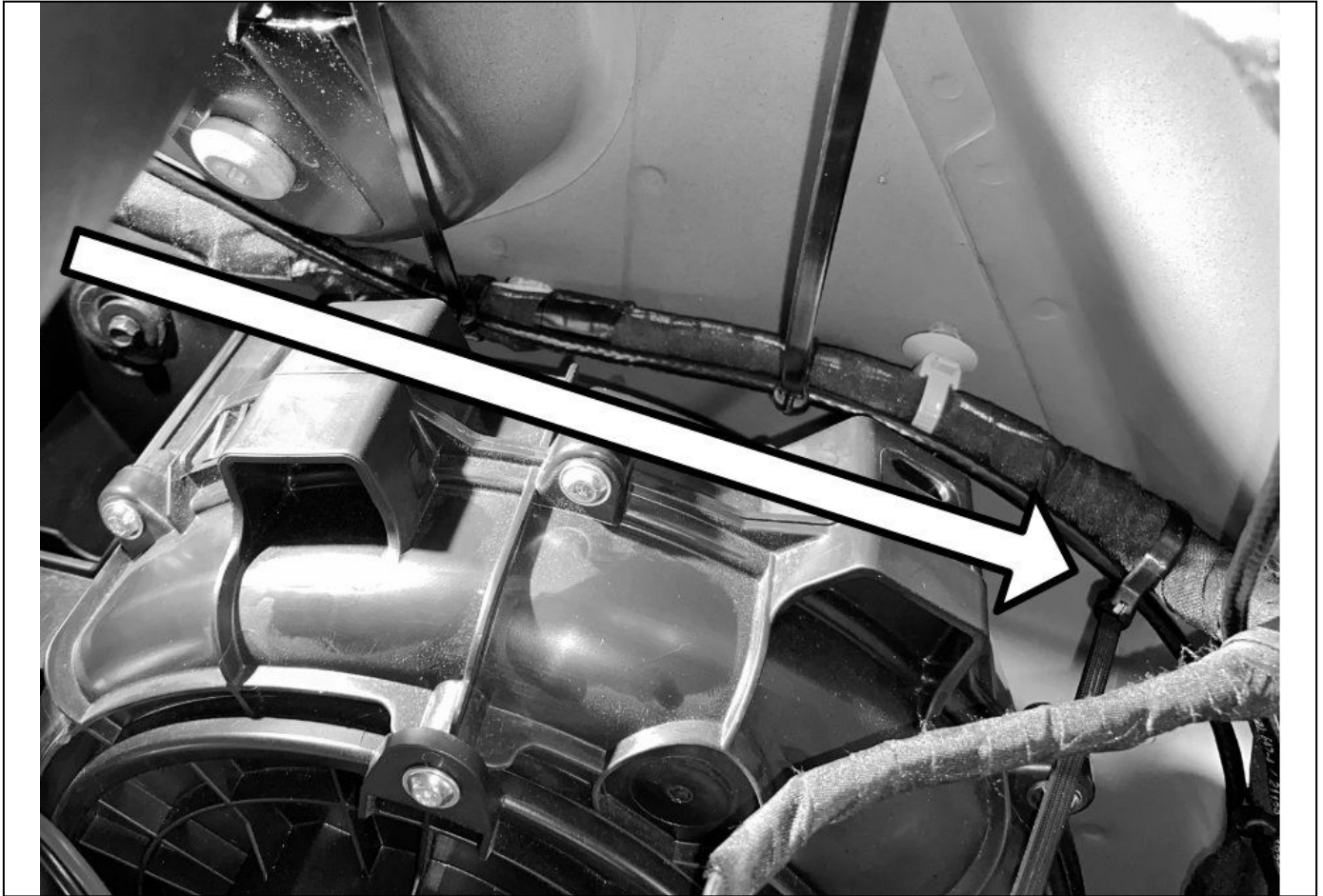

6706125

21. Continue to route the replacement Ethernet Cable following the Body Wiring Harness through the Rear HVAC area.

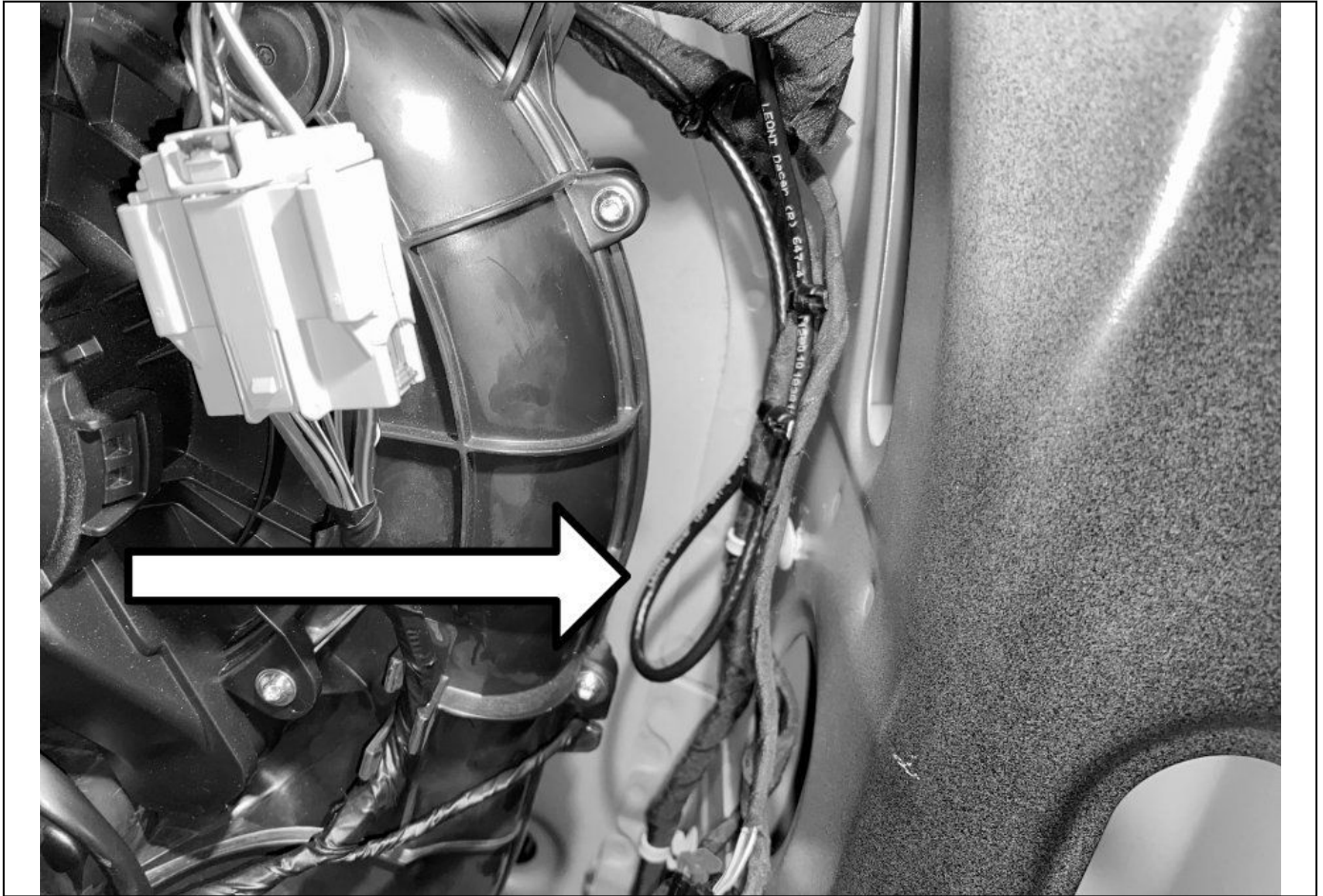

6706129

Important: Ensure the replacement Ethernet Cable will have enough slack so that it is not pulling on the connector at X7 of the Telematic Control Module. Failure to do so could damage the connector at the module.

22. Make a small loop to remove some of the excess cable and secure with a wire tie. Ensure to leave plenty of slack so that the cable will not pull on the connector at X7 of the Telematic Control Module.



6706144



6706155

23. Follow the Body Wiring Harness up the rear of the vehicle and into the rear of the headlining.



6706159

Note: If there is not an adequate amount of slack in the cable return to the loop made in Step 17 and gain extra slack from the loop. Resecure the loop with a wire tie if necessary.

Important: Ensure the replacement cable has plenty of slack and is not pulling on the cable connector plug. Failure to do so could damage the connector at the module.

24. Connect the replacement cable into X7 of the Telematic Control Module. Ensure that the cable has enough slack left to not pull on the X7 connector.



6706169

Important: Avoid excessive wire tie tightness on the replacement cable when securing to the Body Wiring Harness.

25. Add one wire tie around the old cable harness and the new replacement cable near the existing harness tie down. This will aid in securing the connector into the X7 Terminal of the Telematic Control Module.

Important: Avoid excessive wire tie tightness on the replacement cable when securing on the Body Wiring Harness.

26. Secure the replacement cable to the Body Wiring Harness with wire ties. Ensure the replacement cable does not move/rattle.
27. Reinstall the Headliner as necessary. Refer to *Headlining Trim Panel Replacement* in SI.
28. Reinstall the Left-Hand Quarter Upper Trim Panel. Refer to *Quarter Upper Trim Panel Replacement* in SI.
29. Reinstall the Right-Hand Quarter Upper and Lower Trim Panel. Refer to *Quarter lower Rear Trim Panel Replacement (Right Side)* in SI.
30. Reposition the Right-Hand Rear Seat as necessary.
31. Reinstall the Right-Hand Center Pillar Upper and Lower Trim Panel. Refer to *Center Pillar Lower Trim Panel Replacement* in SI.
32. Reinstall the Right-Hand Rear Side Door Sill Garnish Molding. Refer to *Rear Side Door Sill Garnish Molding Replacement* in SI.
33. Reinstall the Right-Hand Front Side Door Sill Garnish Molding. Refer to *Front Side Door Sill Garnish Molding Replacement* in SI.
34. Reinstall the Rear Compartment Floor Stowage Compartment Divider. Refer to *Rear Compartment Floor Stowage Compartment Divider Replacement* in SI.
35. Fold the 3rd row Seat back as necessary.

Parts Information

Causal Part	Description	Part Number	Qty
X	Cable, Body Wiring Harness Modular Pair	26501515	1

Warranty Information

For vehicles repaired under the Bumper-to-Bumper coverage (Canada Base Warranty coverage), use the following labor operation. Reference the Applicable Warranties section of Investigate Vehicle History (IVH) for coverage information.

Labor Operation	Description	Labor Time
*2086678	Ethernet Cable Overlay X7	2.4 Hr.
*This is a unique Labor Operation for Bulletin use only.		

Version	5
Modified	Released September 05, 2024 Revised October 10, 2024 – Removed the GMC Canyon, Hummer EV and Savana, added breakpoint and Middle East. Revised October 25, 2024 – Added note to Condition Section. Revised January 13, 2025 - Added the 2025 Model Year. Revised May 01, 2025– Updated the Concern Section.

