



Countries: AUSTRALIA, BAHAMAS, BOLIVIA, BRAZIL, BELIZE, CANADA, CHILE, TAIWAN, COLOMBIA, COSTA RICA, DOMINICAN REPUBLIC, ECUADOR, EL SALVADOR, GUAM, GUATEMALA, GUYANA, HAITI, HONDURAS, JAMAICA, KOREA, SOUTH KOREA, MEXICO, ARUBA, NEW ZEALAND, NICARAGUA, PANAMA, PERU, PUERTO RICO, RUSSIA, SOUTH AFRICA, TRINIDAD AND TOBAGO, UNITED STATES, URUGUAY, VENEZUELA, Curaçao

Document ID: IK0300071

Availability: ISIS, Bus ISIS, FleetISIS, IsSIR

Major System: Suspension

Current Language: English

Other Languages: NONE

Viewed: 13733

Revision: 6

Created: 12/12/2018

Last Modified: 5/19/2025

Author: David Horner

[Less Info](#)

Hide Details

Coding Information

Copy Link 	Copy Relative Link 	Bookmark View My Bookmarks	Add to Favorites 	Print 	Provide Feedback 	Helpful 51	Not Helpful 7
----------------------	-------------------------------	--	-----------------------------	------------------	-----------------------------	--------------------------	-----------------------------

Title: Non-IROS and CV Rear Air Suspension Ride Height Specifications and Adjustment Procedures

Applies To: All Vehicles, CV, CV iros, CV ride height,

CHANGE LOG

Please refer to the change log text box below for recent changes to this article:

05/19/2025- Added laser ride height tool 09/04/2024 - Added CV until CV Technician Manual can be updated
08/20/2019 - Author updated for feedback purposes
12/17/2018 - Removed CV from vehicle list
12/17/2018 - Initial Article Release

DESCRIPTION

This document will guide the user in determining the correct ride height specifications for non-IROS rear air suspensions for single, tandem, and tridem axle configurations. The ride height measurement is often required for a variety of different diagnostics. Truck-specific ride height procedures can be found on the truck's service manual. If this information is not included in the truck's service manual, please refer to the instructions in this article.

This document also includes the unique suspension ride height measurement for CV trucks with IROS. Skip to [here](#)

International has released a new laser based ride height measuring tool.

- Link to International's new laser [ride height tool](#)
- Link to the IROS [ride height measuring procedure](#)

SPECIAL TOOL(s) / SOFTWARE

- Measuring Tape
- Marker Pen

or

Laser ride height tool 03-068-01

DIAGNOSTIC STEP(s)

WARNING! To prevent property damage, personal injury, and / or death, park vehicle on a hard, flat surface, turn the engine off, set the parking brake, and install wheel chocks to prevent the vehicle from moving in either direction.

WARNING! To prevent property damage, personal injury, and / or death, if the vehicle must be raised, do not work under the vehicle supported only by jacks. Jacks can slip or fall over.

WARNING! To prevent personal injury and / or death, always wear safe eye protection when performing vehicle maintenance.

WARNING! To prevent property damage, personal injury, and / or death, keep flames or sparks away from vehicle and do not smoke while servicing the vehicle's batteries. Batteries expel explosive gases.

WARNING! To prevent property damage, personal injury, and / or death, remove the ground cable from the negative terminal of the battery box before disconnecting any electrical components. Always connect the ground cable last.

Step	Action	Decision
1	DIAGNOSTIC: Can the ride height be measured following the truck's service manual based on the specific air suspension feature code ride height specifications?	<p>Yes. Proceed to Step 2</p> <p>No. The information is not included in the truck's service manual. Proceed to the "Ride Height Measurement and Adjustment procedure" within this iKnow article.</p>

Step	Action	Decision
2	DIAGNOSTIC: Are the ride height <u>adjustment</u> instructions in the truck's service manual?	<p>1. Yes. If the ride height does not meet the specifications, please proceed with adjusting the vehicle's ride height following the manual's procedure.</p> <p>2. No. The information is not included in the truck's service manual. Proceed to the "Ride Height Measurement and Adjustment procedure" within this iKnow article.</p>

Ride Height Measurement Procedure

IMPORTANT: It is very important that the height valve be cycled completely before and after any ride height adjustments. Cycling of the height valve will help make the adjustment more accurate.

1. With air system pressure over 100 psi, deflate the rear suspension to the lowest level.
2. Re-inflate the rear suspension allowing it to return to ride height with air system pressure over 100 psi.

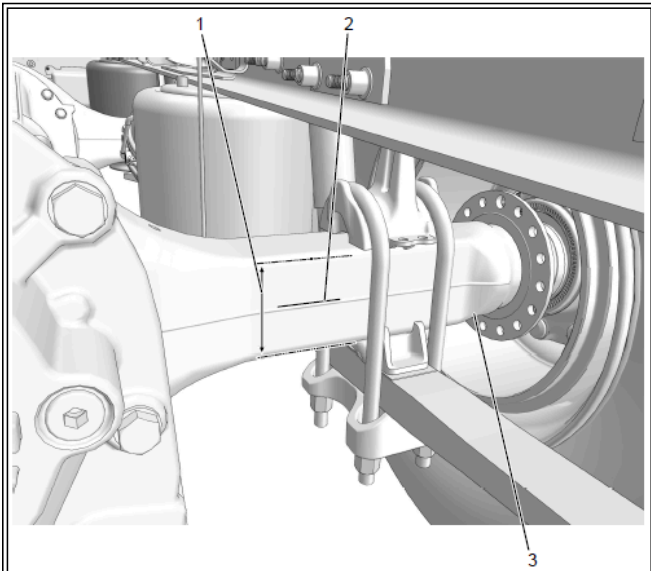

Figure 1: Axle tube front center line

- Item 1: Axle tube front vertical measurement
Item 2: Axle tube center line mark
Item 3: Axle tube

3. At the wheel end of the axle tube (3), closest to the leveling valve, measure vertically on front of axle tube (1) and find the center of the axle tube. See Figure 1.
4. Mark a line on the front of the axle tube indicating the center measurement of the axle tube (2). See Figure 1.

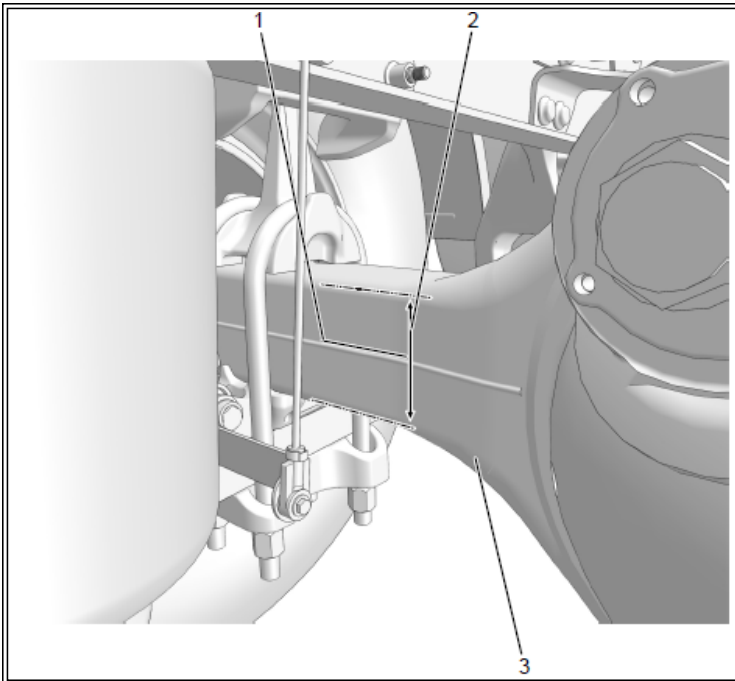

Figure 2: Axle tube rear center line

- Item 1: Axle tube center line mark
- Item 2: Axle tube rear vertical measurement
- Item 3: Axle tube

5. At the same wheel end of axle tube (3), measure vertically on the rear of the axle tube (2) and find the center of the axle tube. See Figure 2.

6. Mark a line on the rear of the axle tube indicating the center measurement of the axle tube (1). See Figure 2.

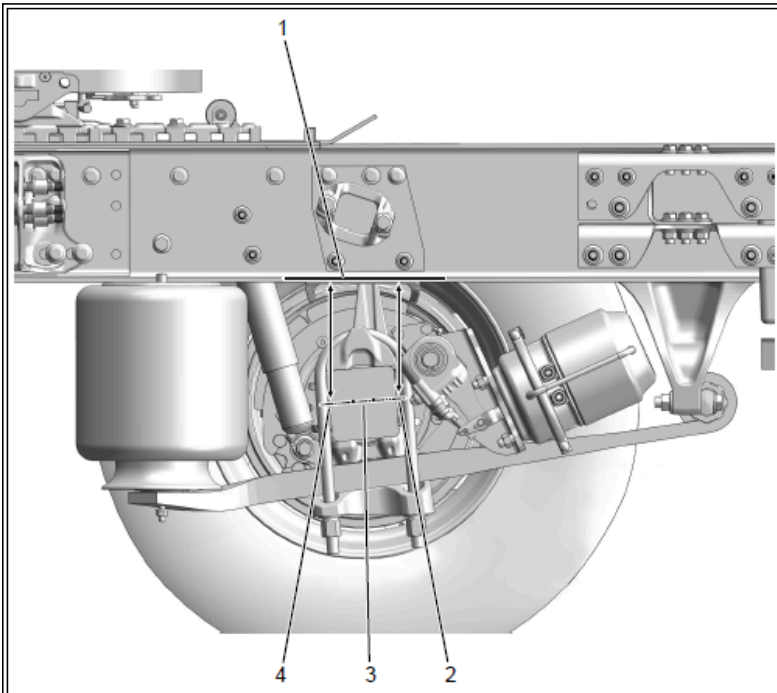

Figure 3: Ride Height Measurement

- Item 1: Bottom of frame rail
- Item 2: Marked line on front of axle tube
- Item 3: True center of axle tube
- Item 4: Marked line on rear of axle tube

7. Measure the vertical distance from the marked line on the front of the axle tube (2) to the bottom of the frame rail (1). See Figure 3. Record measurement.
8. Measure the vertical distance from the marked line on the rear of the axle tube (4) to the bottom of the frame rail (1). See Figure 3. Record measurement.
9. Average recorded measurements made from the front and rear of the axle tube. Averaged measurement will indicate proper ride height from the true center of the axle tube (3) to the bottom of the frame rail (1).
10. Ensure the measurement average reads the same as stated in the Feature Code description (see Table 1).
11. If measurements are out of specification, perform the follow-on procedure to make necessary adjustments.

Table 1: Non-IROS Ride Height Specification by Air Suspension Feature Code

Single Axle Rear Air suspension	
Hendrickson Air Suspension (HAS)	
Feature Code	Ride Height (bottom of frame to center of wheel)
14TAX	9.5 ±1/8"
14TAY	10.6 ±1/8"
Hendrickson Primaax HS (PAX)	
Feature Code	Ride Height (bottom of frame to center of wheel)
14TBZ	9.0 ±1/8"
14TCJ	13.0 ±1/8"
14TCL	9.0 ±1/8"
14TCZ	13.0 ±1/8"
Tandem Axle Rear Air suspension	
Hendrickson Air Suspensions (HAS)	
Feature Code	Ride Height (bottom of frame to center of wheel)
14UKZ	9.5 ±1/8"
14ULA	9.5 ±1/8"
14ULU	9.5 ±1/8"
14ULV	9.5 ±1/8"
14XAL	10.6 ±1/8"
14ULB	9.5 ±1/8"
14ULC	9.5 ±1/8"
14ULS	9.5 ±1/8"
14ULT	9.5 ±1/8"
14XAM	10.6 ±1/8"
Hendrickson Primaax EX Air Suspensions	
Feature Code	Ride Height (bottom of frame to center of wheel)
14UNW	9.0 ±1/8"
14UPS	13.0 ±1/8"
14UNX	9.0 ±1/8"
14UNY	9.0 ±1/8"
14UPU	10.0 ±1/8"
14UPV	9.0 ±1/8"
14UPW	9.0 ±1/8"
14UPX	10.0 ±1/8"
14UPL	10.5 ±1/8"
Hendrickson HTB Air Suspensions	
Feature Code	Ride Height (bottom of frame to center of wheel)
14UNV	9.25 ±1/8"
Raydan Air Link™ Suspensions	
Feature Code	Ride Height (bottom of frame to center of wheel)
14VKL	10.5 ±1/8"
Tridem Axle Rear Air suspension	
Hendrickson Primaax Air Suspensions	
Feature Code	Ride Height (bottom of frame to center of wheel)
14UPC	9.5 ±1/8"
14UPP	12.5 ±1/8"

Ride Height Adjustment Procedure

IMPORTANT: It is very important that the height valve be cycled completely before and after any ride height adjustments. Cycling of the height valve will help make the adjustment more accurate.

For Ride Height Specifications, please refer to Table 1.

If travel exceeds specification:

1. Do not bend height control system brackets or rods to adjust suspension height.
2. Loosen the lever arm bolt that holds the arm to the height control valve.
3. Pivot the lever arm down to exhaust air from the suspension, lowering the chassis to some point below the correct air ride spring height.
4. Final air ride spring height must be achieved by adding air to the suspension, not exhausting.
5. Add air until axle travel reaches the proper value according to the specifications table.
6. When the correct axle travel value has been achieved, retighten the lever arm bolt.

If travel is less than specification:

1. Do not bend height control system brackets or rods to adjust suspension height.
2. Loosen the lever arm bolt that holds the arm to the height control valve.
3. Push the lever arm up to add air to the suspension, raising the chassis, until axle travel reaches the proper value according to the specifications table.
4. When the correct axle travel value has been achieved, retighten the lever arm bolt.

CV with IROS suspension ride height check

1. CV ride height with IROS 14TBL 14TBM, 14TBN, 14TDG
 1. 01CCA= 5 3/4"
 2. 01CGH= 4 5/8"
2. Prepare truck for inspection

IMPORTANT: It is important that the height valve be cycled completely before and after any ride height adjustments. Cycling the suspension dump valve will make the adjustment more accurate.

1. Park the vehicle on a flat surface and do not set the parking brake- chock steer axle tires
2. With air system pressure over 100 psi, deflate the rear suspension to the lowest level
3. Re-inflate the rear suspension allowing it to return to ride height with air system pressure over 100 psi.
4. Measure from the top of the axle to the bottom of the frame (4 5/8" target shown below applies to frame 01CGH)

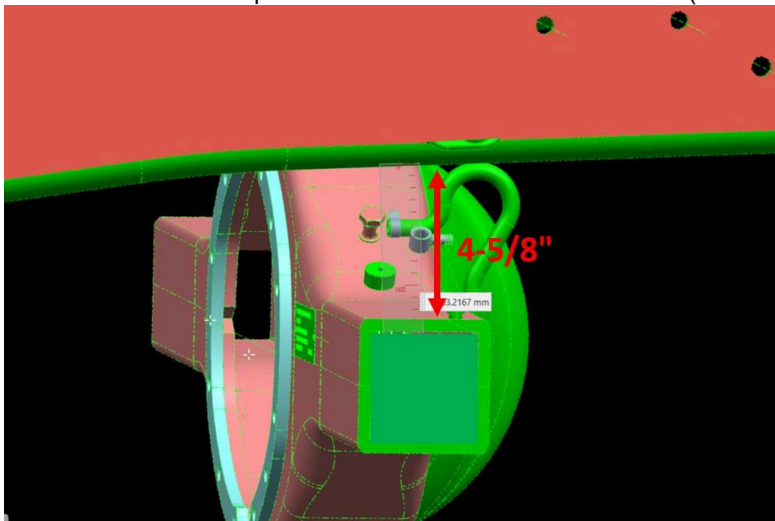

- 3.
4. If adjustment is needed follow the process cited earlier in this article and then recheck.

WARRANTY INFORMATION

Warranty Claim Coding:

Refer to the [Warranty Coding Manual](#) for Group and Noun Codes.

Standard Repair Time(s):

Refer to the [SRT Manual](#) for Repair Times

OTHER RESOURCES

[Master Service Information Site](#)

 Hide Details

Feedback Information

Viewed: 13732

Helpful: 51

Not Helpful: 7

No Feedback Found