

Technical Service Bulletin

Topic	93 e-tron GE various warning messages in the cluster, electric motor leaking P0AA600
Market area	United States 444 Volkswagen of America, Inc. (6444)
Brand	Audi
Transaction No.	2073858/8
Level	EH
Status	Released for publishing
Release date	May 14, 2025

New customer code

Object of complaint	Complaint type	Position
engine -> engine operation -> electro-drive mode	noises, vibrations -> jerking	
engine -> engine operation -> electro-drive mode	noises, vibrations -> vibrating	
engine -> engine operation -> electro-drive mode	functionality -> misfire	
engine -> engine operation -> electro-drive mode	functionality -> no function	
engine -> engine operation -> electro-drive mode	functionality -> does not switch on/connect	
engine -> engine operation -> electro-drive mode	functionality -> cannot be switched on/activated	
transmission -> transmission control operation	noises, vibrations	
transmission -> transmission control operation	functionality	
transmission -> power distribution, transmission of power	functionality	
entire vehicle -> assemblies	leaks	
entire vehicle -> assemblies -> transmission assembly	leaks -> not watertight	
engine -> engine operation -> electro-drive mode	noises, vibrations -> noise	
engine -> engine operation -> electro-drive mode	noises, vibrations -> pinging	

Vehicle data

e-tron GE MJ19-25

Sales types

Type	MY	Brand	Designation	Engine code	Gearbox code	Final drive code
GE*	2019	A		*	*	*
GE*	2020	A		*	*	*
GE*	2021	A		*	*	*
GE*	2022	A		*	*	*
GE*	2023	A		*	*	*
GE*	2024	A		*	*	*

Documents

Document name
master.xml
etron_electric_drive_motor_leak_sost_april_2023.pdf

Condition

REVISION HISTORY		
Revision	Date	Purpose
8	-	Revised <i>Service</i> (Updated ETKA info)
7	02/20/2025	Revised <i>Warranty</i> (Updated labor operations)
6	01/23/2025	Revised title (Updated title)

Customer states:

- A Drive System/Electrical System Malfunction message (Figure 1) appears in the in the instrument cluster; the warning may not be present at the time of inspection.



Figure 1. Warning lamp associated with message.

Workshop findings:

The following DTC is stored in *the Battery manager control module -J840-*, (address word 008C):

- Hybrid/EV Battery Voltage System Isolation.

and/or

- During a workshop visit, an internal leak (e.g., coolant drip container is full; coolant leaking from active chamber on front or rear axle) has been determined on the electric drive motor.

Technical Background

Electric drive motor damaged due to internal coolant leak.

Production Solution

Not applicable.

Service

Check coolant leak and localize the source of the leak:

Only if the following information is given can it be assumed that the **electric drive motor is damaged** due to an internal coolant leak:



In this case, check the seal on the coolant expansion tank beforehand and re-secure it after performing any required work. Vehicles should never be operated without a correctly filled cooling system.

Rear axle (Figure 2):

Drip container is overflowing:

- Coolant leaking from active chamber.

Drip container is empty:

- Coolant leaking from active chamber, particularly on vehicles with low mileage.

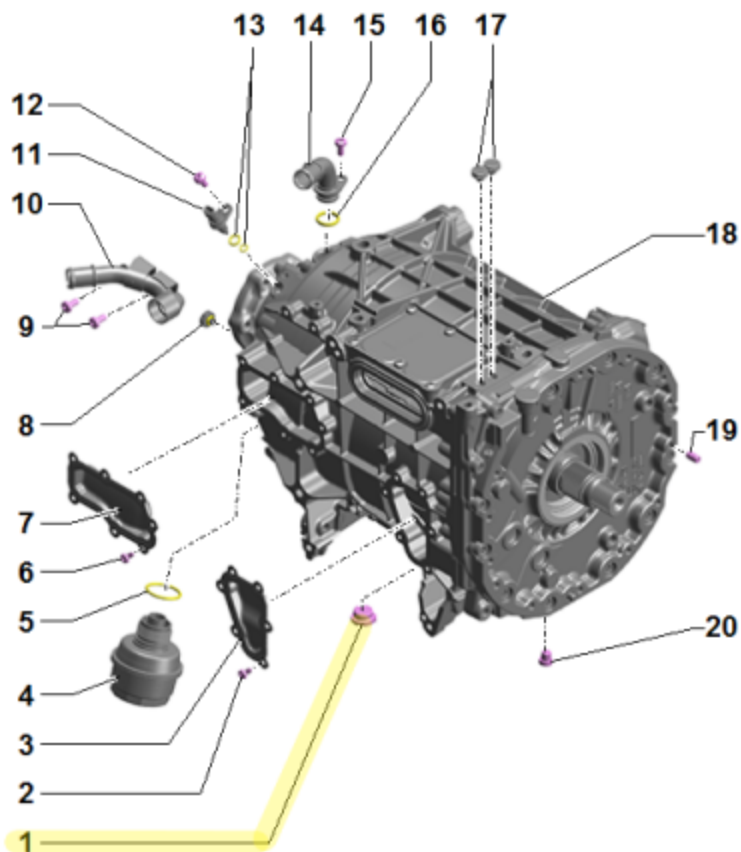

Figure 2: (1) Drain plug.

Front axle (Figure 3):

- Coolant leaking from active chamber.

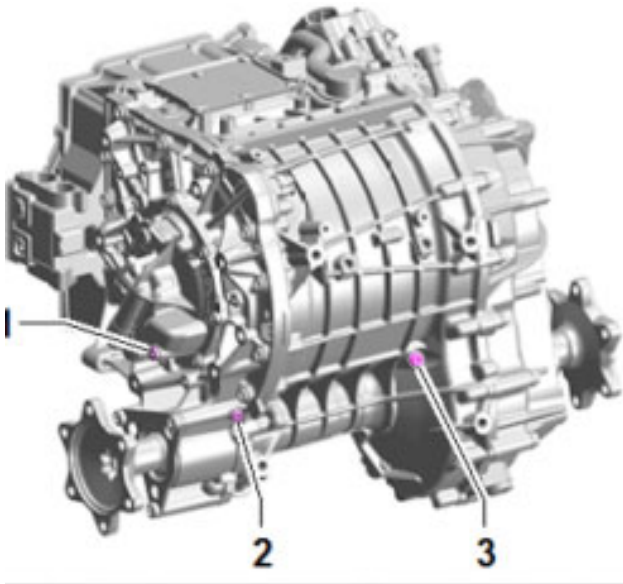

Figure 3: 1) *Resolver cover:* A few milliliters of coolant leakage is not an issue from a technical perspective. 2) *Active chamber:* No coolant may escape from the bores.

Caution:

The power electronics must not be replaced if the electric drive motor is leaking.

Please note the market-specific ETKA information.



If the power and control electronics for electric drive must be replaced as a group, then this must be billed separately (see warranty accounting instructions).

Warranty

Claim Type:	<ul style="list-style-type: none"> If the vehicle is outside of any warranty, this Technical Service Bulletin is informational only. 		
Service Number:	9340 (If front electric drive motor was replaced)		
Damage Code:	0050		
OR			
Service Number:	9346 (If rear electric drive motor was replaced)		
Damage Code:	0050		
Labor Operations:	Check electric drive motor for front axle for leaks	9340 0199	15 TU
	Check electric drive motor for rear axle for leaks	9346 0199	10 TU
	Replace front drive motor	9340 55xx	See SRT with associated operations

Replace electric drive motor for rear axle	9346 55xx	See SRT with associated operations
Replace 2 electric drive motors for rear axle, e-tron S	9346 56xx	See SRT with associated operations
Deactivate and activate the high-voltage system	9310 835X	See SRT with associated operations
Charge battery	2706 8950	See SRT with associated operations
GFF	0150 0060	Time stated on the diagnostic protocol
Test drive before the service procedure	No Allowance	0 TU
Test drive after the service procedure	0121 0004	10 TU
Claim Comment:	As per TSB 2073858/8	

All warranty claims submitted for payment must be in accordance with the *Audi Warranty Policies and Procedures Manual*. Claims are subject to review or audit by Audi Warranty.

Additional Information

All parts and service references provided in this TSB (**2073858**) are subject to change and/or removal.

©2025 Audi of America, Inc. All rights reserved. The information contained in this document is based on the latest information available at the time of printing and is subject to the copyright and other intellectual property rights of Audi of America, Inc., its affiliated companies, and its licensors. All rights are reserved to make changes at any time without notice. No part of this document may be reproduced, stored in a retrieval system, or transmitted in any form or by any means, electronic, mechanical, photocopying, recording, or otherwise, nor may these materials be modified or reposted to other sites without the prior expressed written permission of the publisher.