



## S-Series™

### 2.0 Grayhill Display and T27 Telematics Control Unit (TCU) Update

**Date:** May 7, 2025

**Bulletin Name:** FDM-SVC-027

**Model:** Oshkosh S-Series

**Units Affected:** 2.0 Front Discharge Mixers  
VIN 800613 - 821848

### Purpose:

This bulletin provides instruction for replacing a Micronet display with an updated Grayhill overhead display and T27 TCU.

### Notice:

- This bulletin should be read and understood in its entirety before performing this procedure.
- All procedures outlined in the bulletin must be performed by skilled service personnel. Refer to the product service manual for descriptions of maintenance procedures.

### SAFETY NOTICE

Perform your company's Lockout/Tagout procedure. If your company does not have a Lockout/Tagout procedure, follow OSHA 1910.147 and 1910.146 Confined Space as appropriate.

### SAFETY NOTICE

Use appropriate Personal Protective Equipment (PPE) as required by your company.

### Tools and Equipment Required

Customer to supply:

- Hand tools
- Drill and 3/16" drill bit
- Tape measure
- Torque wrench (inch pounds and foot pounds)
- Sand paper
- Laptop\*
- Orchestra software\*
- PCAN adapter cable\*
- FCM software\*

\*Front Control Module (FCM) update to be performed by S-Series service personnel

## Parts Required

Item	Part Number	Description	Qty.
1	A000W843	SCR, BTN, SOC #8-32 X 1.12 SS	2
2	A000E542	LOCTITE, #242	A/R
3	A000F010	INSERT, HEX 0.25-20 X 0.165 ZY	4
4	A000F374	NUT, HEX, LKNY 6-32 SS	2
5	A001C246	NUT, ACRN #8-32 SS NS	2
6	A000V859	WASH, FLT, SAE #6 X 0.38 X 0.05 SS	2
7	A000W179	BRKT, DISPLAY, MTG	1
8	A000X442	WIRE HARN, JUMPER DISPLAY	1
9	A001K952	MODULE, DSPL 3D70, 9.2.50, ASSY	1
10	A001K385	MODULE ASSY, TCU, 12.0.0	1
11	A001F369	WIRE HARN, JUMPER, TELEMATICS	1
12	A001B842	PLATE, DISPLAY CONNECTOR	1
13	A001B897	SCR, PAN, XR #6-32 X 1.50 SS	2
14	A000C018	CABLE TIE 6.30 X 0.20	7
15	A000V858	WASH, FLT, SAE #8 X 0.44 X 0.05 SS	2
16	A001K954	SOFTWARE, FCM, S-SERIES, 9.2.51	1

## Procedure

### Recording Vehicle Information

1. Log in as Service Manager and record all active/set vehicle options. See Figure 1.

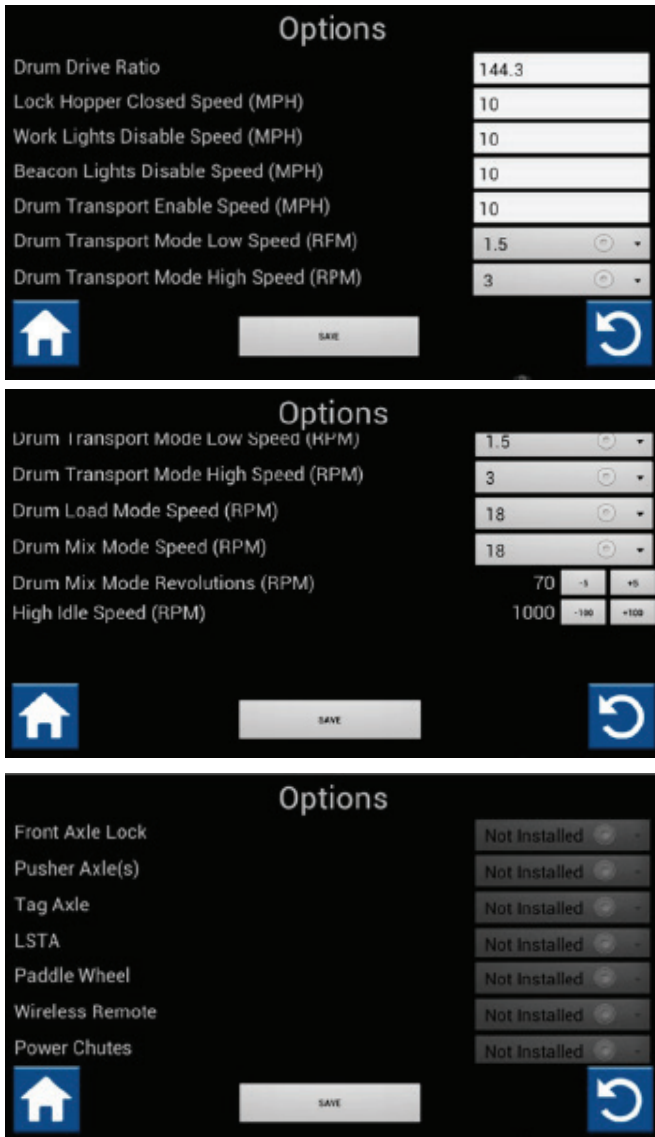


Figure 1

2. Record total drum revolutions. See Figure 2.

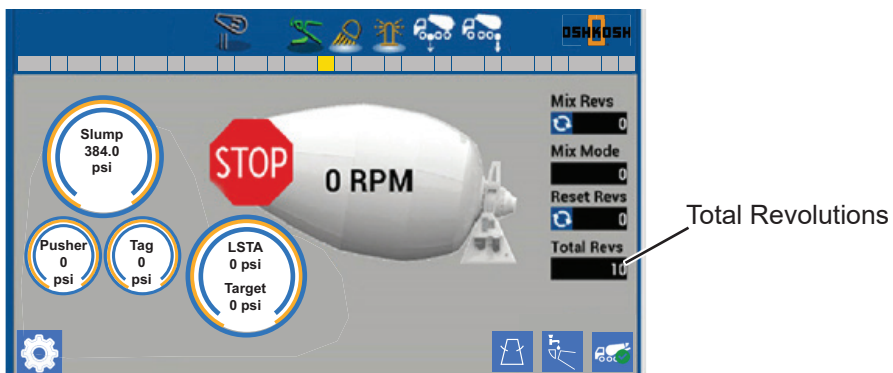
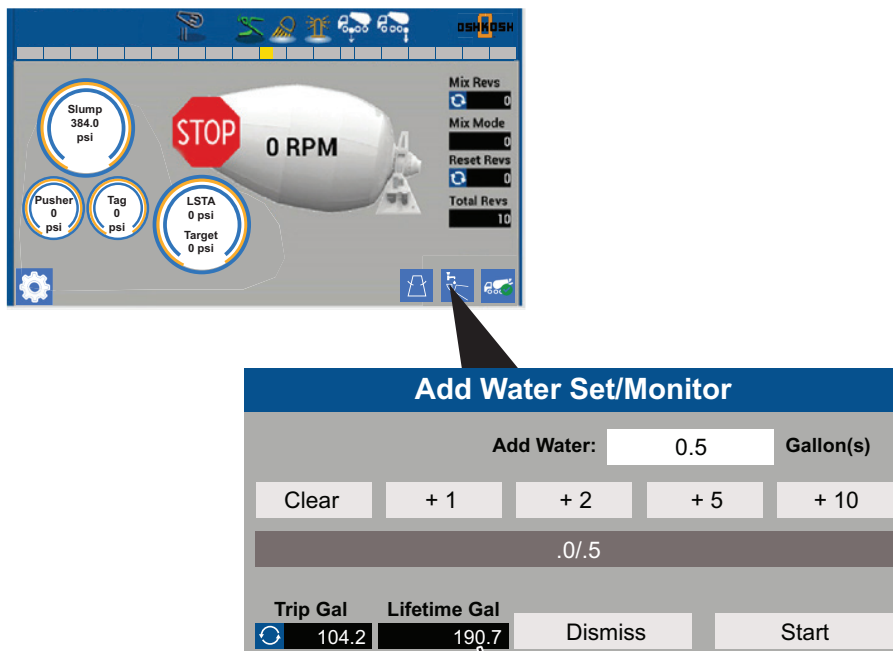


Figure 2

3. Record lifetime gallon value. See Figure 3.



Lifetime Gallons  
Figure 3

4. Record slump profiles. See Figure 4.

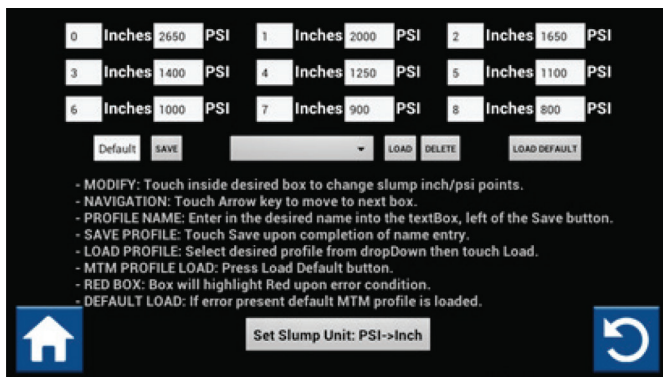


Figure 4

### Lockout/Tagout

5. Place unit on a flat surface, engage parking brake, chock truck tires, and perform your company's Lockout/Tagout procedure. If your company does not have a Lockout/Tagout procedure, follow OSHA 1910.147 and 1910.146 Confined Space as appropriate.

6. The vehicle's BATTERY DISCONNECT switch is located on the left-hand side of the battery box. Use the battery disconnect switch when performing any maintenance so the vehicle cannot accidentally be started.

- a. Turn the battery disconnect switch (Figure A, Item 1) counterclockwise so the hole on the switch aligns with the hole in the bracket (Figure A, Item 2).
- b. Install the safety lockout device ring (Figure B, Item 1) through the holes on the battery disconnect switch and the bracket.
- c. Install a padlock (Figure B, Item 2) onto the safety lockout device ring, lock it, and put the key in your pocket. If more than one person is working on the vehicle, each person must install his or her own padlock.

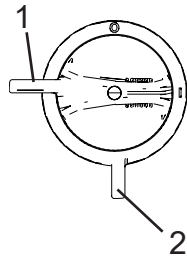


Figure A

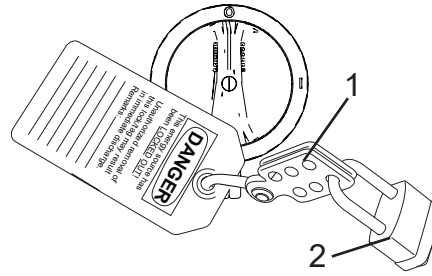


Figure B

### Display and TCU Installation

7. Remove four screws and washers securing radio panel to overhead console. See Figure 5. Save screws and washers for reinstallation of radio panel.
8. Disconnect harness connector and antenna cable from back of radio. Set radio panel aside.

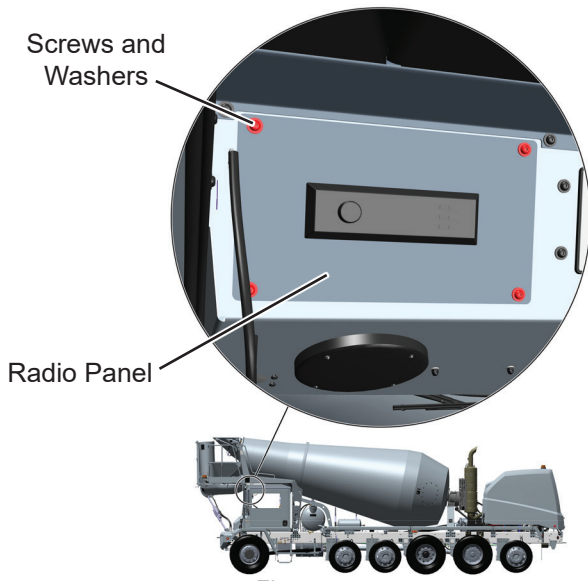


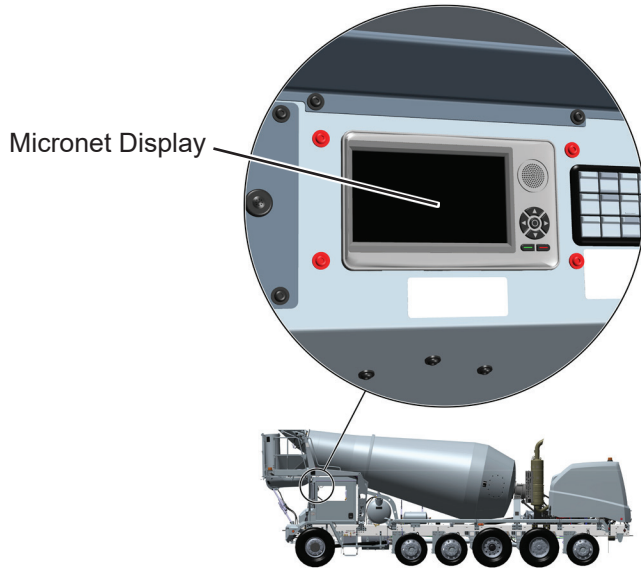
Figure 5

9. Remove four screws and washers securing overhead console access panel. See Figure 6. Save screws and washers for reinstallation of access panel.

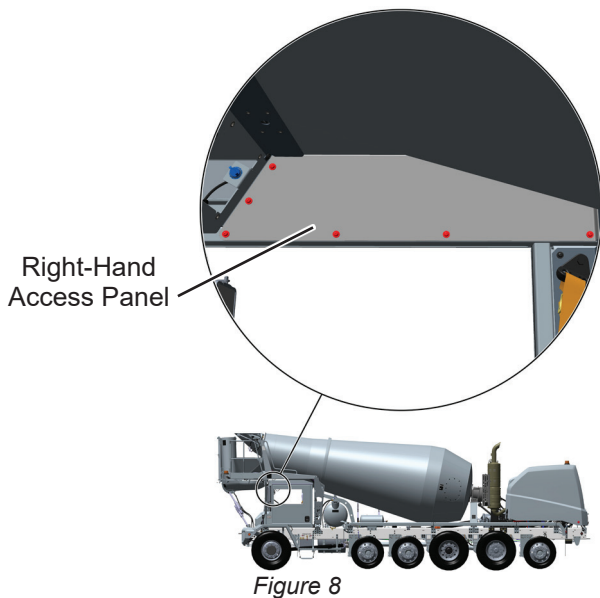


Figure 6

10. Remove four screws and washers securing Micronet display panel to overhead console. See Figure 7. Save screws and washers for reinstallation.
11. Disconnect five cables connected to Micronet display and remove display and bracket from overhead console.
12. Remove four screws and washers securing Micronet display to mounting bracket. Save screws and washers for installation of Grayhill display to new mounting bracket. The Micronet display and mounting bracket will not be reused.



13. Remove seven screws and washers securing right-hand access panel to overhead console. See Figure 8. Save screws, washers, and access panel for reinstallation.



14. Remove fifteen screws and washers securing side console cover. See Figure 9. Save screws, washers, and side console cover for reinstallation.
15. Disconnect connector C18 from joystick and remove side console cover. Set cover aside for reinstallation later.

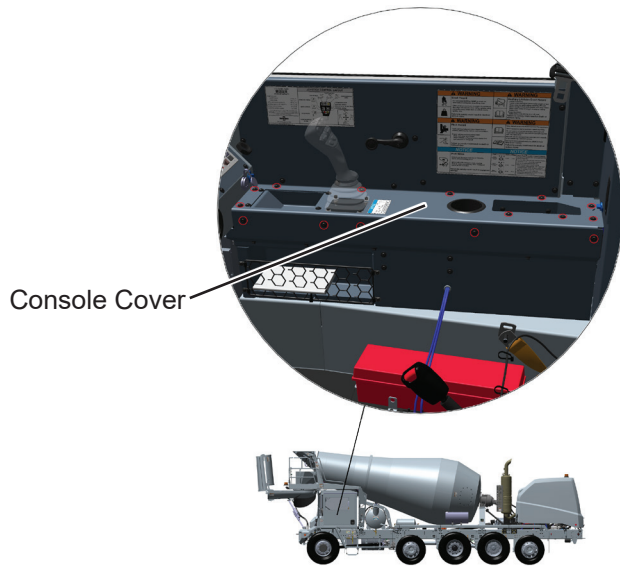


Figure 9

16. Remove two screws and washers securing clipboard holder. See Figure 10. Save screws and washers for reinstallation of clipboard holder side console cover.
17. Remove clipboard holder from side console and set aside for reinstallation later.

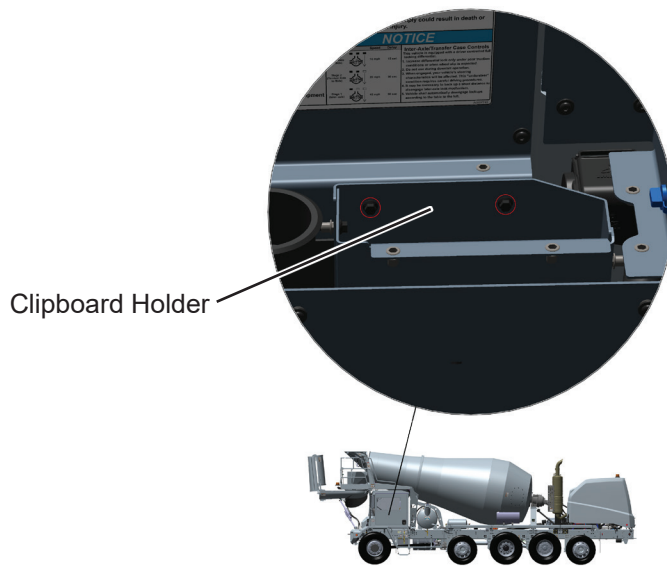


Figure 10

18. Open cab electrical cabinet door.

19. Install jumper harness (A000X442) starting in upper raceway. See Figure 11. Route front control module connectors C155A and C155B end of harness into electrical cabinet and down to front control module (FCM).

20. Route display connectors C1529, C1530, and C1538 end of harness into overhead console. See Figure 11.

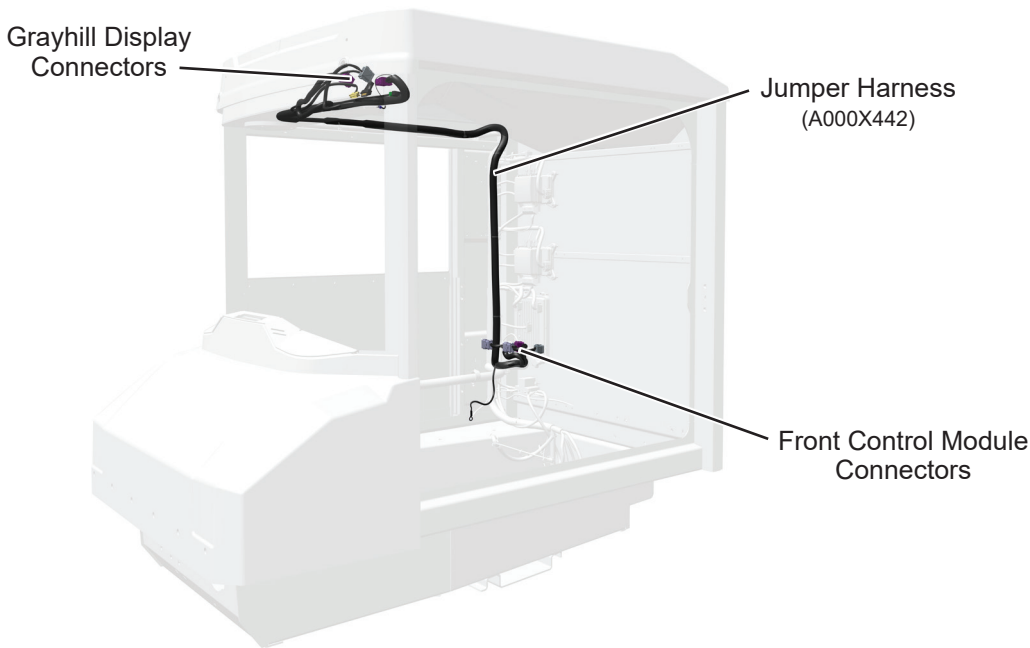


Figure 11

### NOTE

The electrical cabinet power port connector may need to be disconnected while installing jumper harness.

21. Disconnect cab harness connectors C155A and C155B from FCM. See Figure 12.

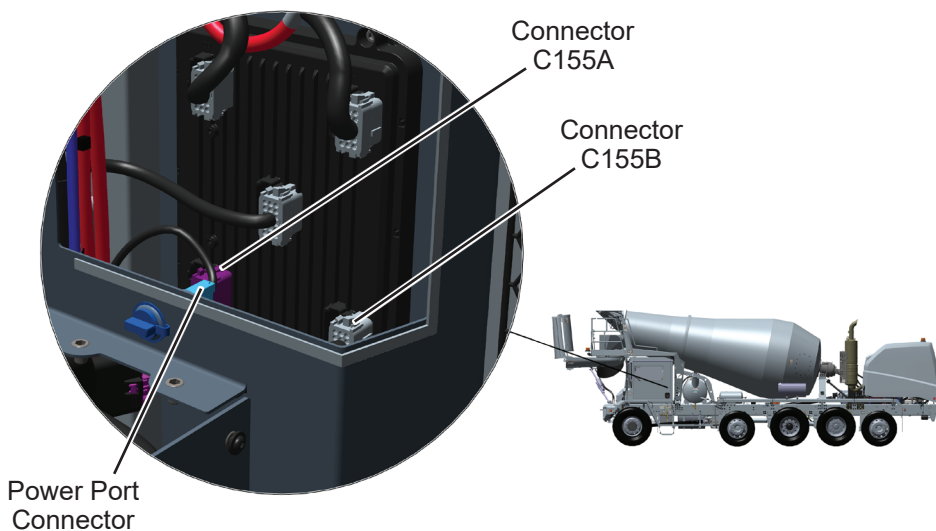


Figure 12

22. Connect cab harness connector C155A removed in Step 21 to jumper harness connector C155A\_F\_JUMP. See Figure 13.

23. Connect cab harness connector C155B removed in Step 21 to jumper harness connector C155B\_F\_JUMP. See Figure 13.
24. Connect jumper harness connector C155A\_M\_JUMP to FCM A. See Figure 13.
25. Connect jumper harness connector C155A\_M\_JUMP to FCM B. See Figure 13.

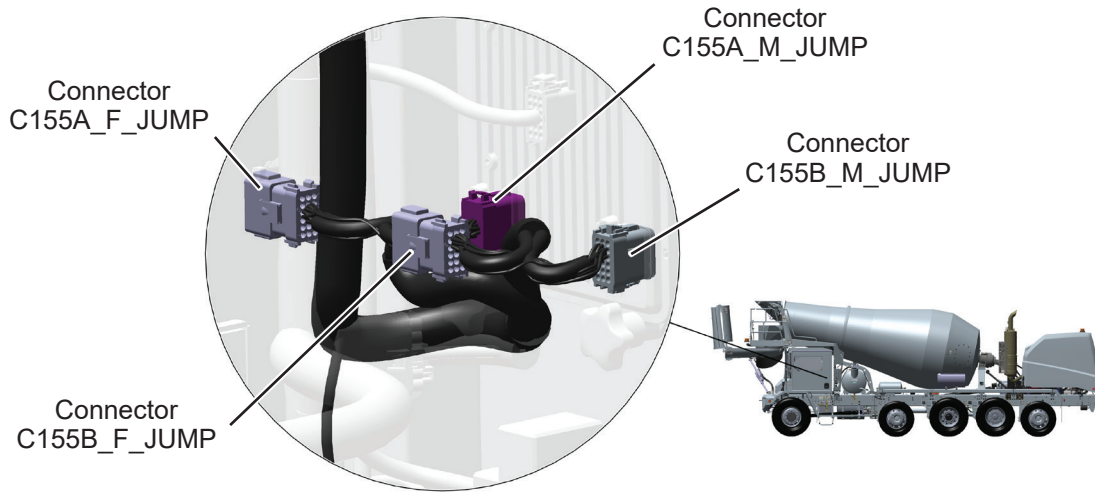


Figure 13

26. Route jumper harness ground through bottom of electrical cabinet into side console. See Figure 14

**Vehicles Prior to SN 809269.**

- a. Loosen and remove existing console hex bolt. See Figure 14.
- b. Remove paint from around where hex bolt was removed.
- c. Attach jumper harness ground wire terminal to hex bolt and reinstall hex bolt.

**Vehicles After SN 809269.**

- a. Loosen and remove existing ground bolt with ground connections and nut. See Figure 14.
- b. Add jumper harness ground wire to ground bolt and existing ground connections.
- c. Reinstall ground bolt and nut. Final tighten ground bolt and nut to 35 ft. lbs.

Prior to SN 809269

SN 809269 and later

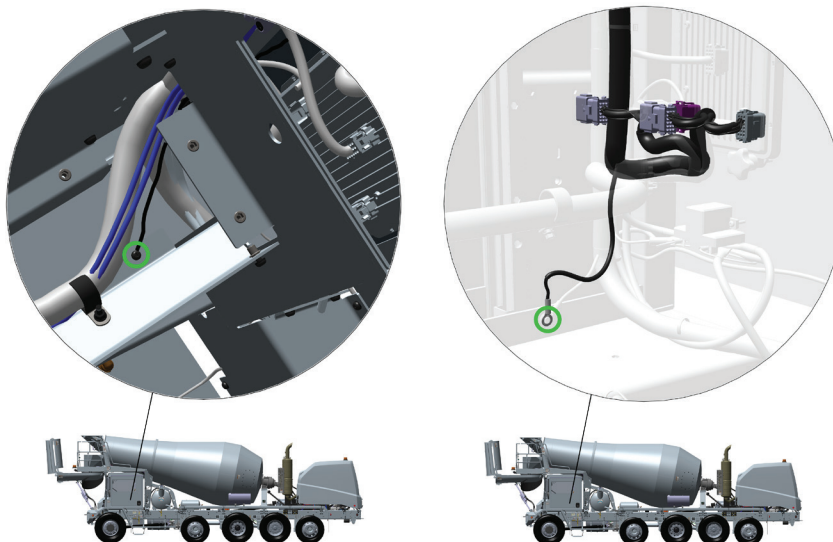


Figure 14

27. Close and secure cab electrical cabinet door.
28. Reinstall clipboard holder with two screws and washers removed in Step 16. See Figure 15. Final tighten

screws to 75 in lbs.

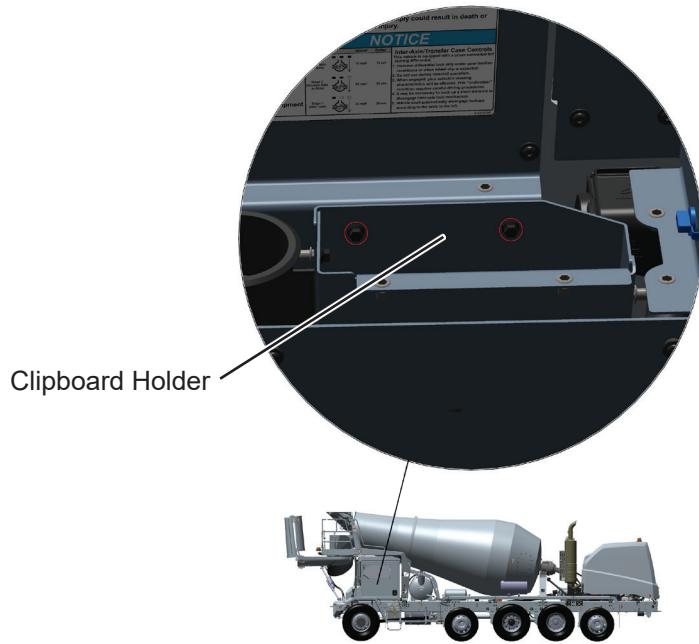


Figure 15

29. Reconnect connector C18 removed in Step 15 to side console joystick.

30. Reinstall console cover with fifteen screws and washers removed in Step 14. See Figure 16. Final tighten screws to 75 in. lbs.

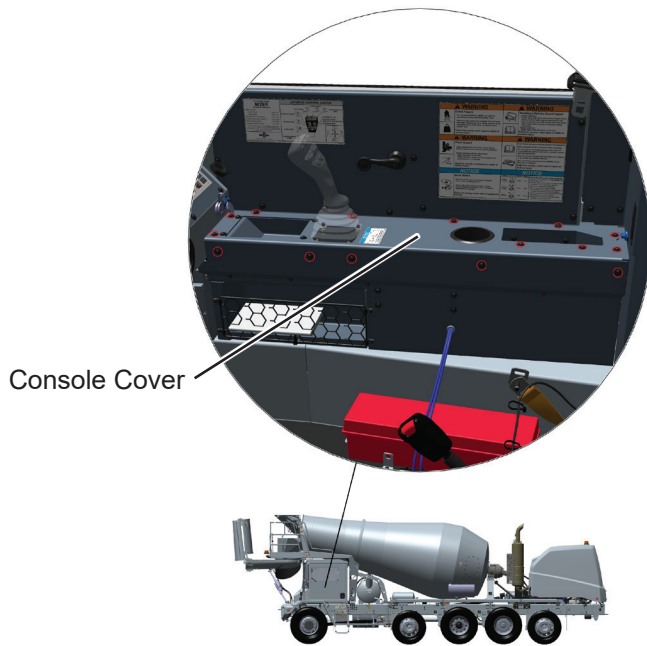


Figure 16

31. Secure Grayhill display (A001K952) to mounting bracket (A000W179) with four screws and washers removed in Step 12. See Figure 17. Final tighten screws to 10 in. lbs.
32. Install inserts (A000F010) in display bracket. See Figure 17.

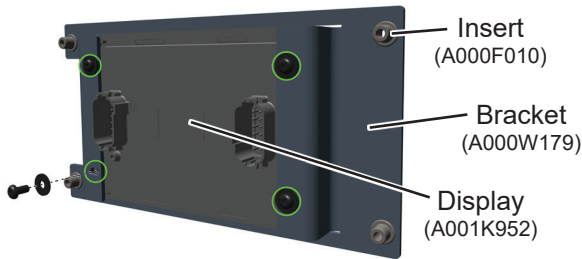


Figure 17

33. Slide display and bracket assembly into overhead console through display opening. See Figure 18.
34. Connect jumper harness connector C1538 to port A on back of display.
35. Connect jumper harness connector C1529 to port B on back of display.
36. Secure display bracket to overhead console with four screws, and flat washers removed in Step 12. See Figure 18.

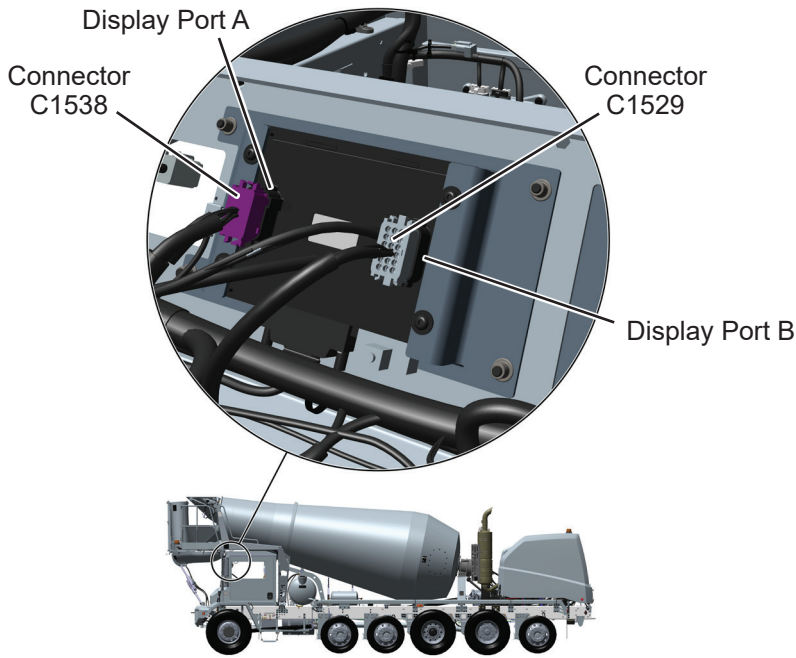


Figure 18

37. Mark and drill two 3/16 inch holes in bottom of overhead console per dimensions in Figure 19.

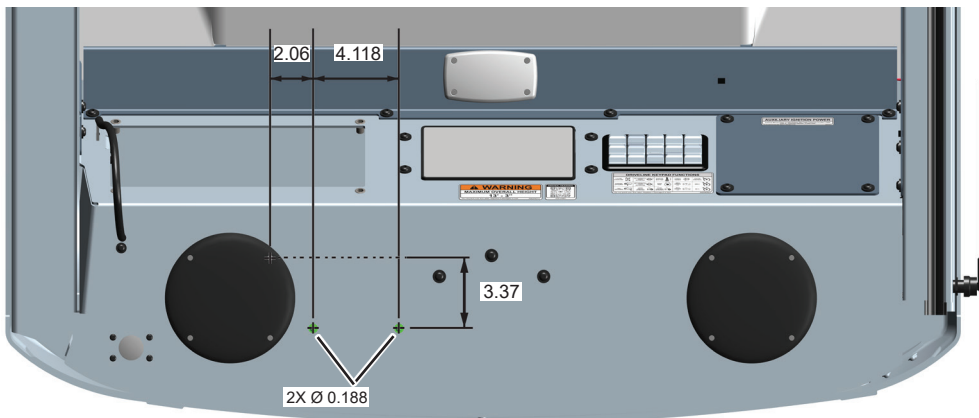


Figure 19

38. Loosen and remove right rear speaker mounting screw and nut. See Figure 20. Save screw and nut for reinstallation.
39. Remove paint from area around where speaker mounting screw and nut was removed in the overhead console. See Figure 20.
40. Place TCU (A001K385) in overhead console through radio panel opening. See Figure 20.
41. Secure TCU module to overhead console through holes drilled in Step 37 with screws (A000W843), washers (A000V858), and acorn nuts (A001C246). See Figure 20. Install screws from top and washers and acorn nuts from the bottom, acorn nuts to be visible from driver's seat. Final tighten hardware to 17 in lbs.
42. Connect jumper harness (A001F369) to connector C1530 and TCU. See Figure 20.
43. Connect cellular and GPS cables disconnected from Micronet display to TCU. See Figure 20.
44. Reinstall right rear speaker mounting screw with jumper harness ground terminal on speaker mounting screw, and install nut removed in Step 38. Final tighten to 17 in. lbs.

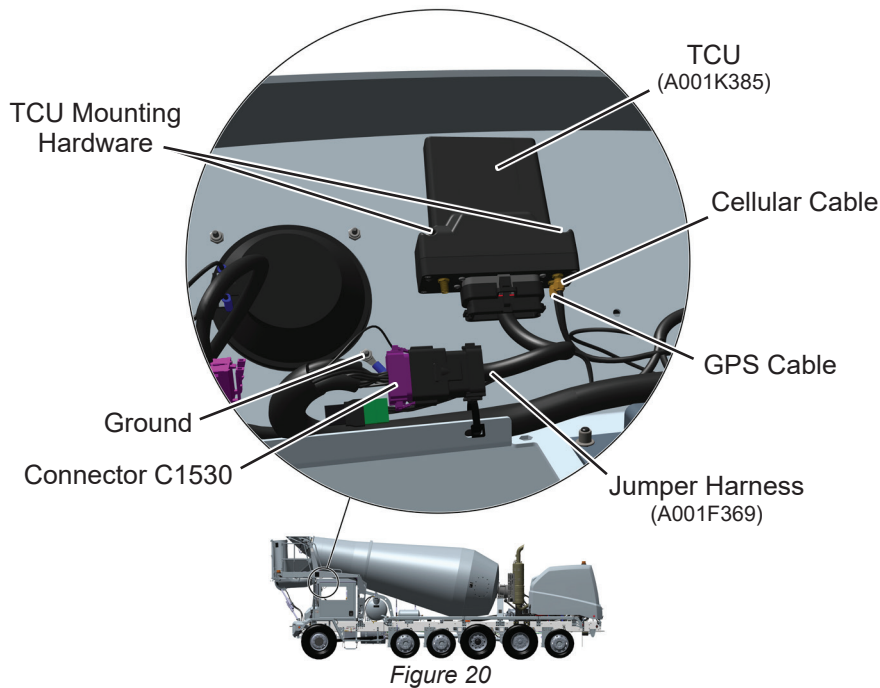


Figure 20

45. Locate connector C311 and DVI connector, that were disconnected from the Micronet display, through the right-hand overhead console access panel, See Figure 21.
46. Connect jumper harness connector C1549 to DVI connector. See Figure 21.
47. Remove the two thumb screws from connector C311. Thumb screws will not be reused.
48. Connect jumper harness connector C1531 to connector C311. See Figure 21.

49. Install connector plate (A001B842), screws (A001B897), washers (A000V859), and nuts (A000F374) to secure connector C311 to C1531. Do not over tighten hardware and bend connector plate. See Figure 21.

<b>NOTE</b>
<b>The USB connector previously connected to the Micronet display will not be used with the Grayhill display.</b>

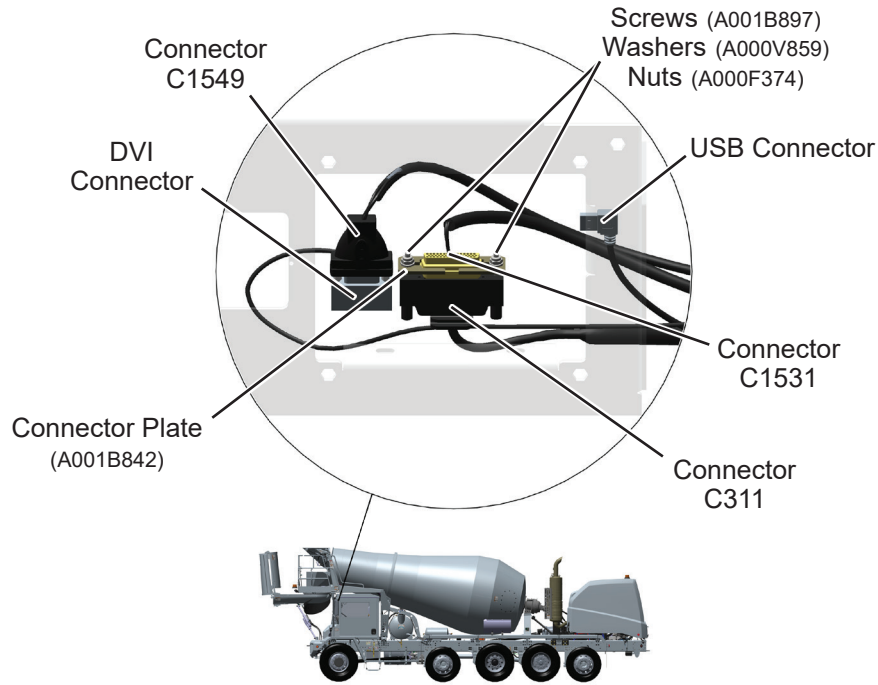


Figure 21

50. Secure all cable routings and excess cable lengths with cable ties (A000C018). See Figure 22.



Figure 22

51. Turn vehicle ignition switch ON and make sure Grayhill display and TCU lights turn on. If display or TCU do not power on turn ignition switch OFF and check connectors. Repeat process of checking the display and TCU lights turning on.

52. Reinstall right-hand access panel with seven screws and washers removed in Step 13. See Figure 23. Final tighten screws to 75 in lbs.

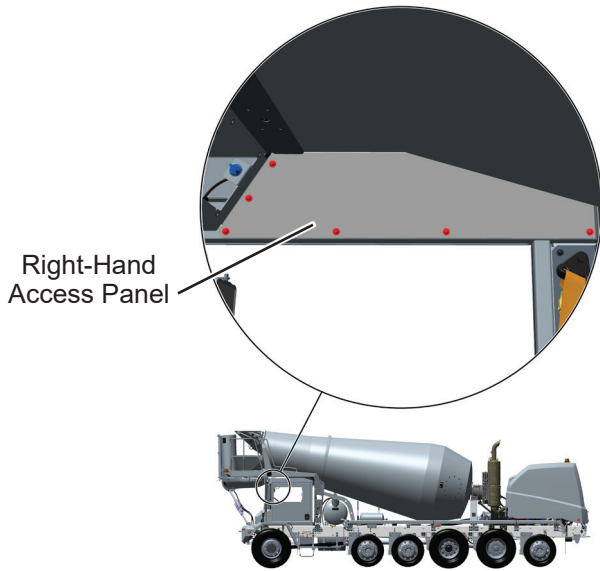


Figure 23

53. Reinstall overhead console access panel with four screws and washers removed in Step 9. See Figure 24. Final tighten screws to 75 in lbs.

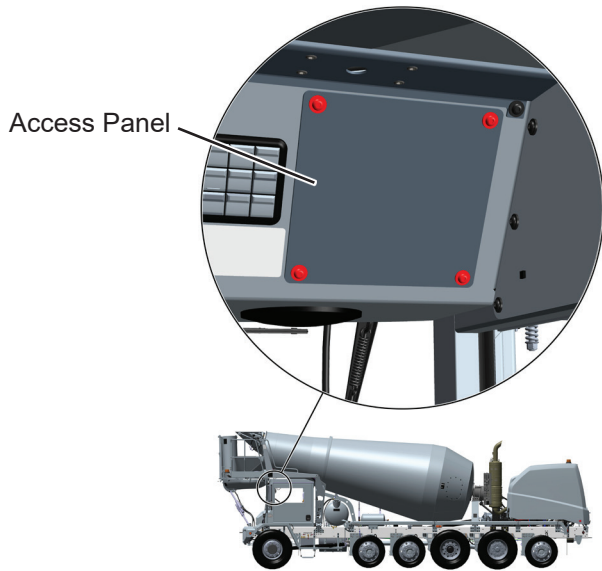


Figure 24

- 54. Reconnect harness connector and antenna to back of radio.
- 55. Reinstall radio panel to overhead console with four screws and washers removed in Step 7. See Figure 25. Final tighten screws to 75 in lbs.

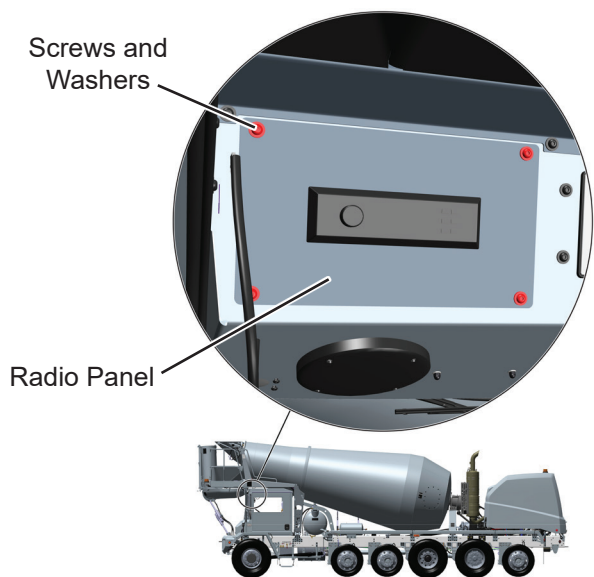


Figure 25

- 56. Remove lockout/tagout and tire chocks.

**Front Control Module Update**

**Contact S-Series service for information on required software updates.**

- 57. Update front control module (FCM) to v9.2.51 using the following procedure.
  - a. Disconnect rear control module (RCM) connector C373A to prevent inadvertently updating the wrong control module. See Figure 26.

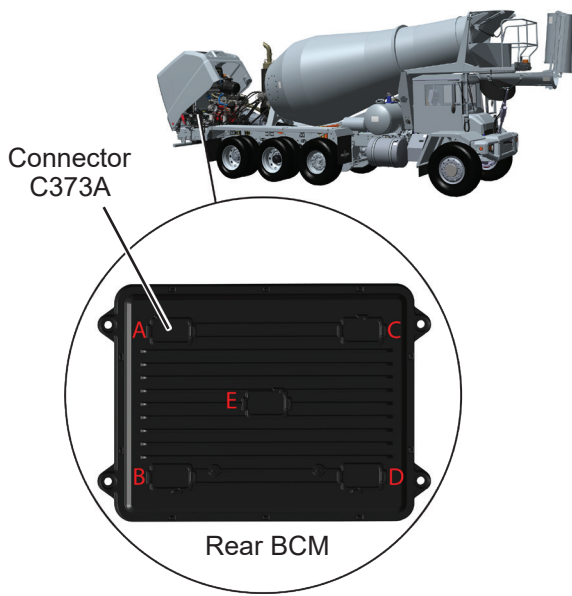


Figure 26

- b. Plug in PCAN adapter cable to laptop. Remove terminating resistor receptacle and connect PCAN adapter to green connector C12 near driver's left foot area in cab. See Figure 27.

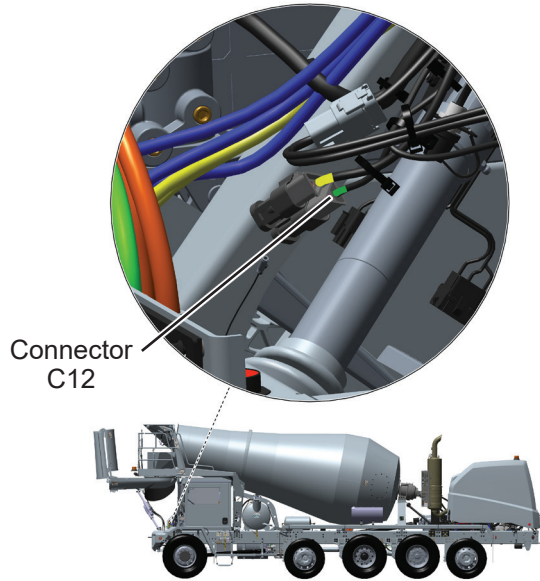


Figure 27

- c. Turn vehicle ignition switch to ON position.
- d. Turn vehicle battery disconnect switch OFF.
- e. On laptop open Orchestra. See Figure 28.
- f. Select the *Downloaders Tab* followed by the *Firmware Download* tab. See Figure 28.
- g. Select *Grid Connect* radio button. See Figure 28.
- h. Set *Select Baud* rate to 500k. See Figure 28.
- i. Click *Start* button. See Figure 28.

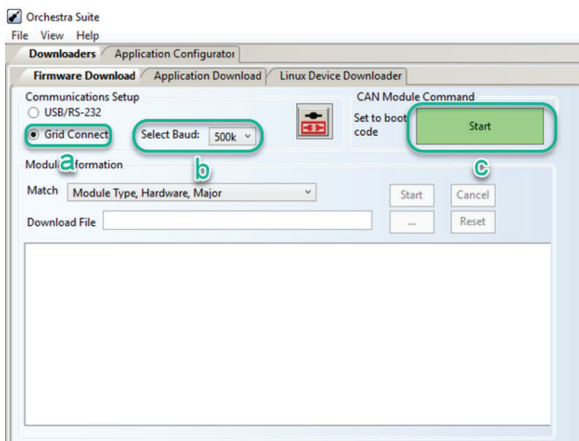


Figure 28

- j. Turn vehicle battery disconnect switch ON.

- k. In Orchestra click *Stop*.
- l. Select the *Connect* button. See Figure 29. When connected the keypads blink and the dome lights turn off. If keypads are not blinking and dome lights are not off, select *Connect* button again.
- m. Enter *450* in *Filter* field to search for *CL-450-101-00*. See Figure 29.
- n. Double click on *CL-450-101-00* from module list to select. See Figure 29.
- o. Browse to the computer drive or flash drive location where the controller update programming files are located and select the file to you want to load by clicking on it. See Figure 29.
- p. Click *Start* button. See Figure 29. Status will say downloading to approximately 5 minutes.
- q. Click *OK* when finished

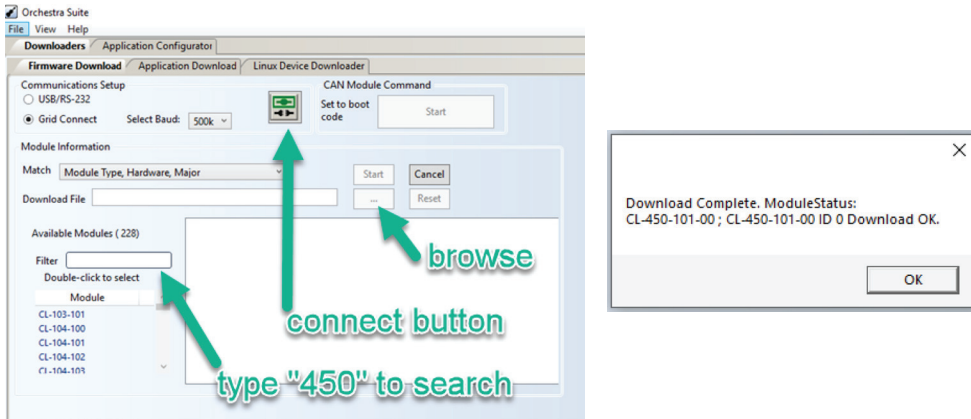


Figure 29

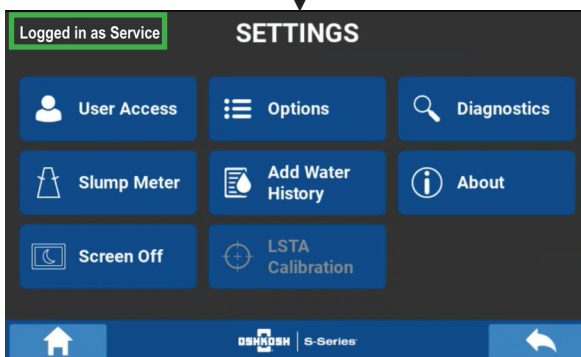
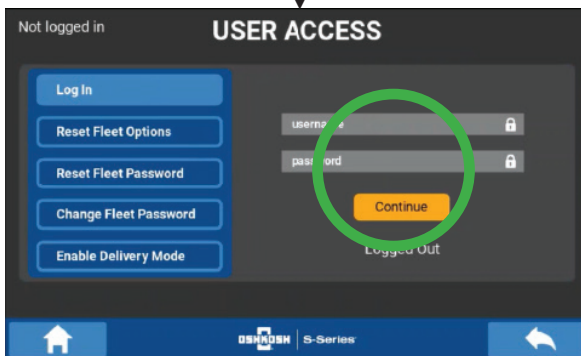
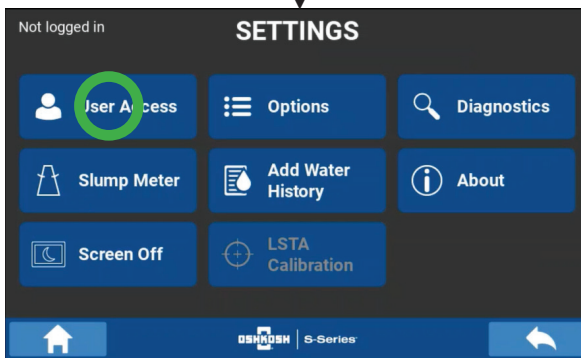
- 58. Make sure the vehicle's rear work lights function as intended after FCM software update is complete. If rear work lights do not function as intended repeat Step 57.
- 59. Disconnect PCAN device from connector C12 and reinstall terminating resistor.
- 60. Reconnect rear PDM connector C373A disconnected in Step 57a.

## Display Setup

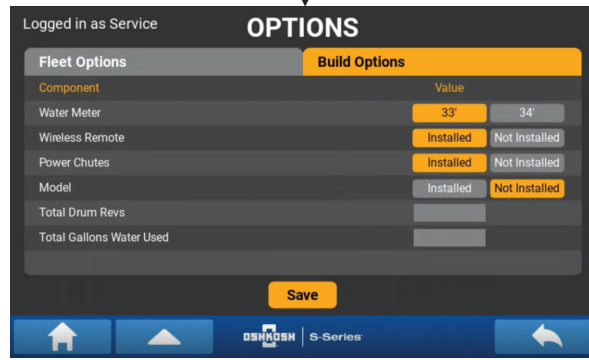
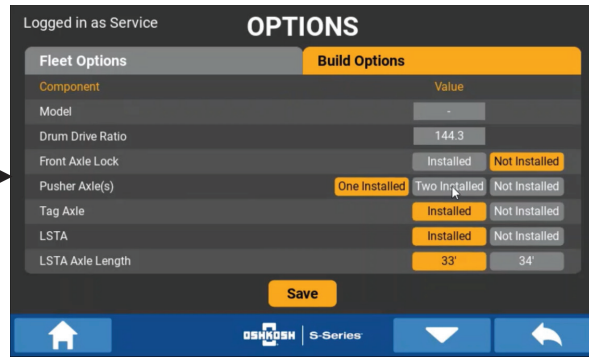
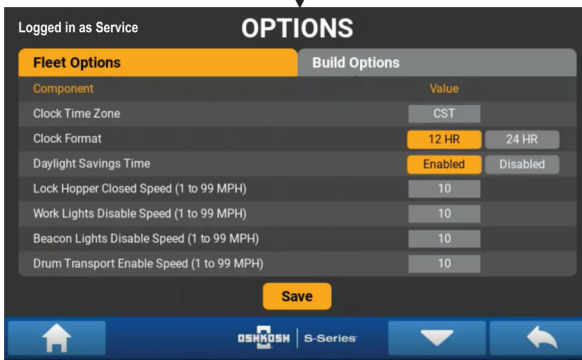
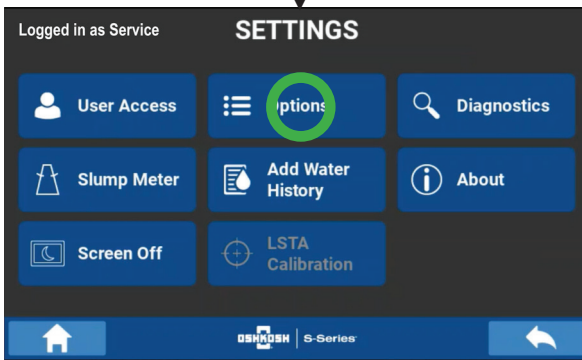
61. Setup Grayhill display using the following procedure.

- a. Power on display and log in as service manager.

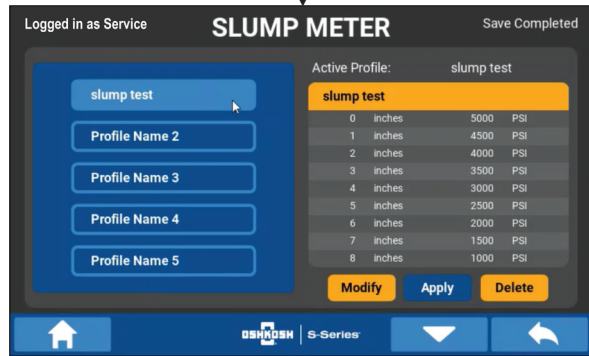
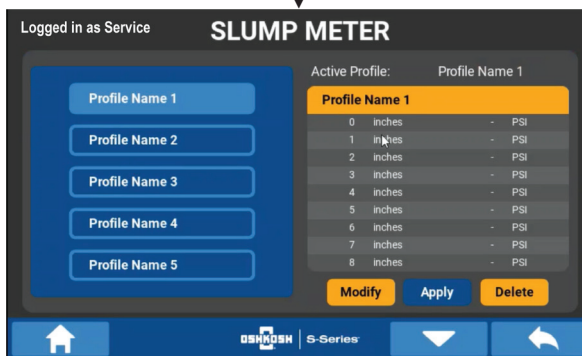
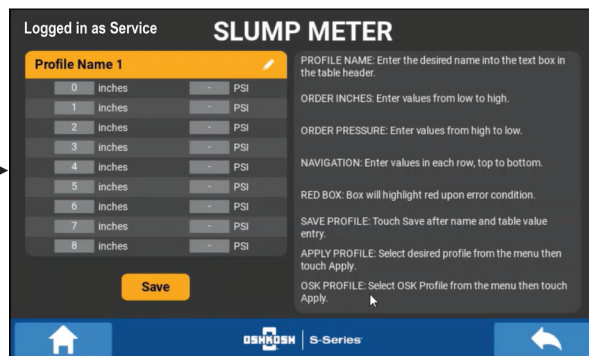
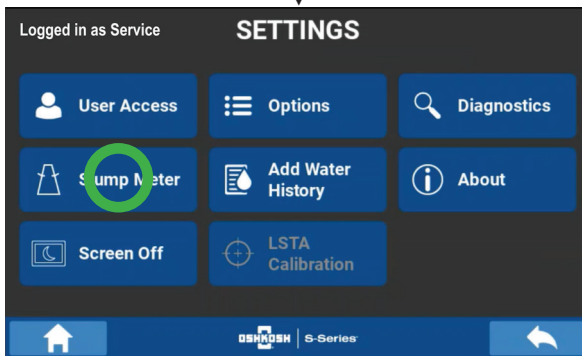
*Settings -> User Access -> User Name & Password -> Continue -> Return to Settings Screen*



- b. Verify/enter vehicle option selections recorded in Step 1.  
*Settings -> Options*
- c. Set time to appropriate time zone, daylight savings status, and preferred format (12 vs 24 hour).
- d. Verify/enter lifetime drum revs recorded in Step 2.
- e. Verify/enter lifetime gallons recorded in Step 3.



f. Create slump profiles to match slump profiles recorded in Step 4.



- g. Return to User Access screen and log out.
- h. Press home button to return to main screen.
- i. Turn vehicle ignition OFF to complete display setup procedure.

### ClearSky™ Verification

- 62. Make sure truck is in a location with adequate cellular and GPS service. Truck may need to be outside for adequate service.
- 63. Turn truck ignition switch to ON position and wait until overhead display shows home screen
- 64. Log into ClearSky (<https://clearsky.mcneiluscompanies.com>) See Figure 30. If an account needs to be created contact ClearSky support ([clearskysupport@oshkoshcorp.com](mailto:clearskysupport@oshkoshcorp.com)).

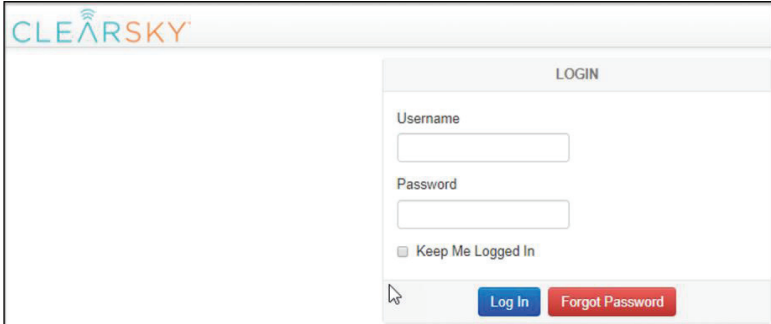


Figure 30

- 65. Search for truck serial number (last six digits of truck VIN) in ClearSky search window. See Figure 31.

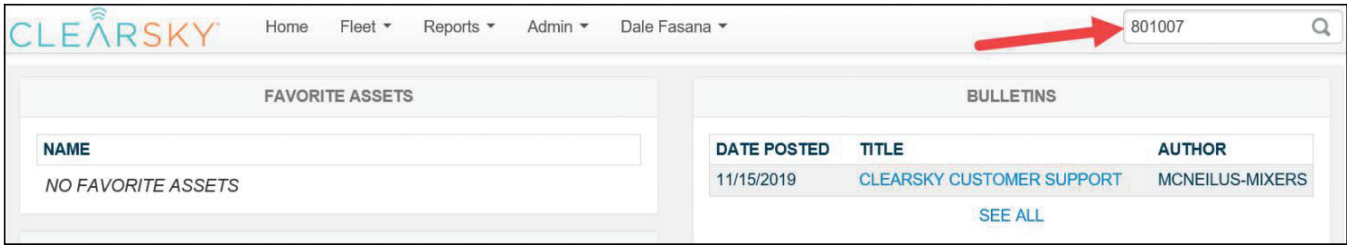


Figure 31

- 66. Make sure the truck's serial number appears in the search results Assets window and select the truck from the search results. See Figure 32.

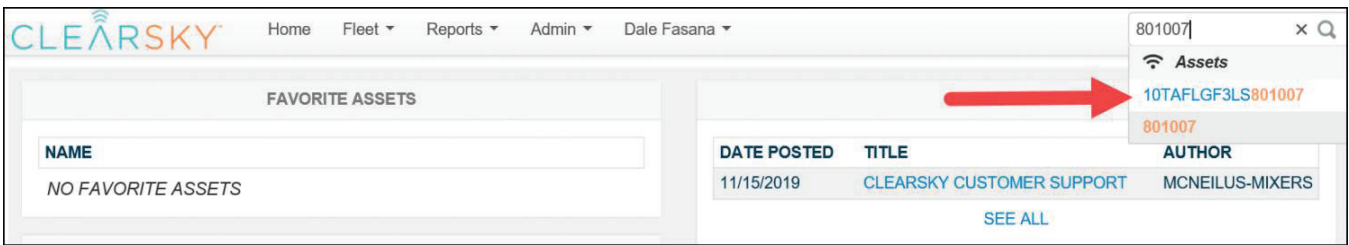


Figure 32

- 67. Make sure the truck VIN displayed in the information box in the upper left corner of page is correct. See Figure 33.

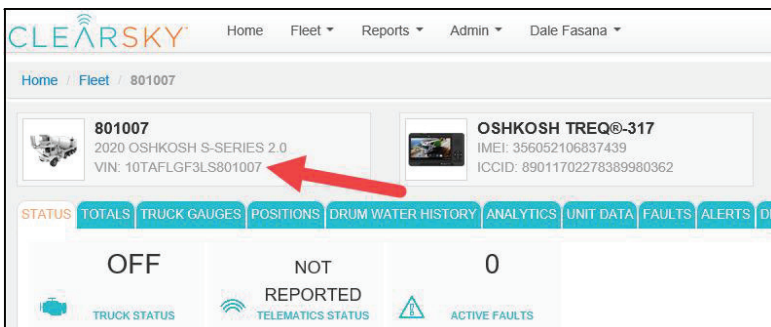


Figure 33

68. Check the GPS by clicking on the SUMMARY tab and making sure the map shows the current location of the truck. The time stamp displayed should be within 2 minutes of the current time. See Figure 34.

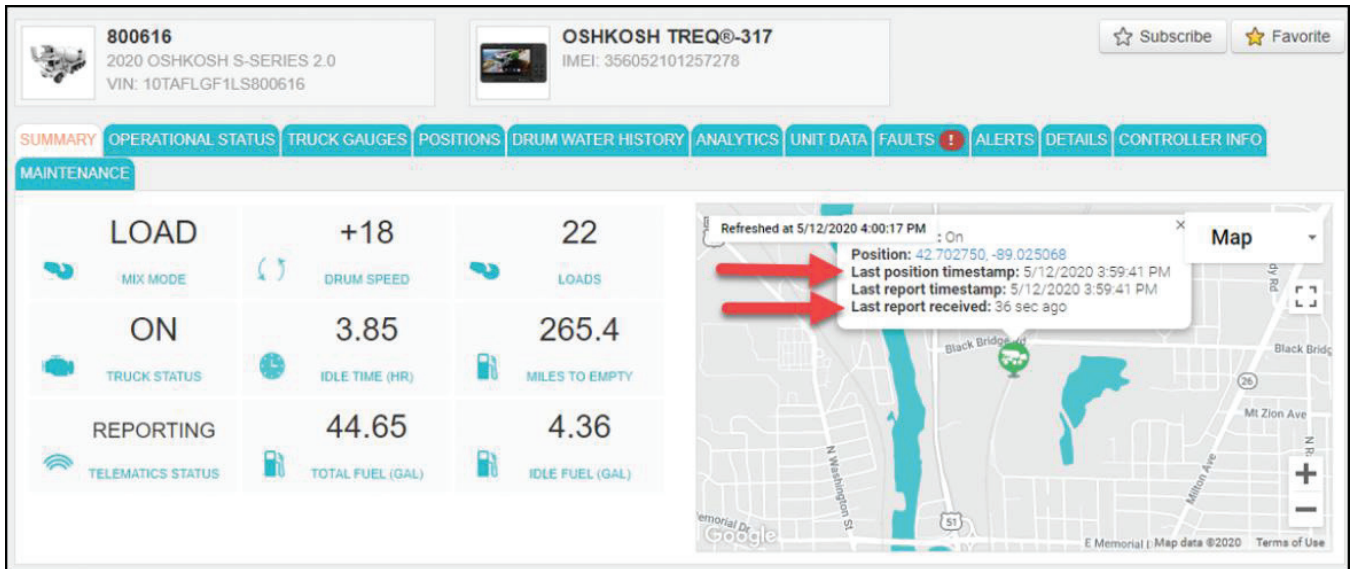


Figure 34

69. Check the ClearSky data by clicking on the TRUCK GAUGES tab and making sure the ClearSky gauges match what is shown on the gauges in the truck. See Figure 35. Gauges include fuel level, front air tank pressure, rear air tank pressure, odometer, and engine hours.

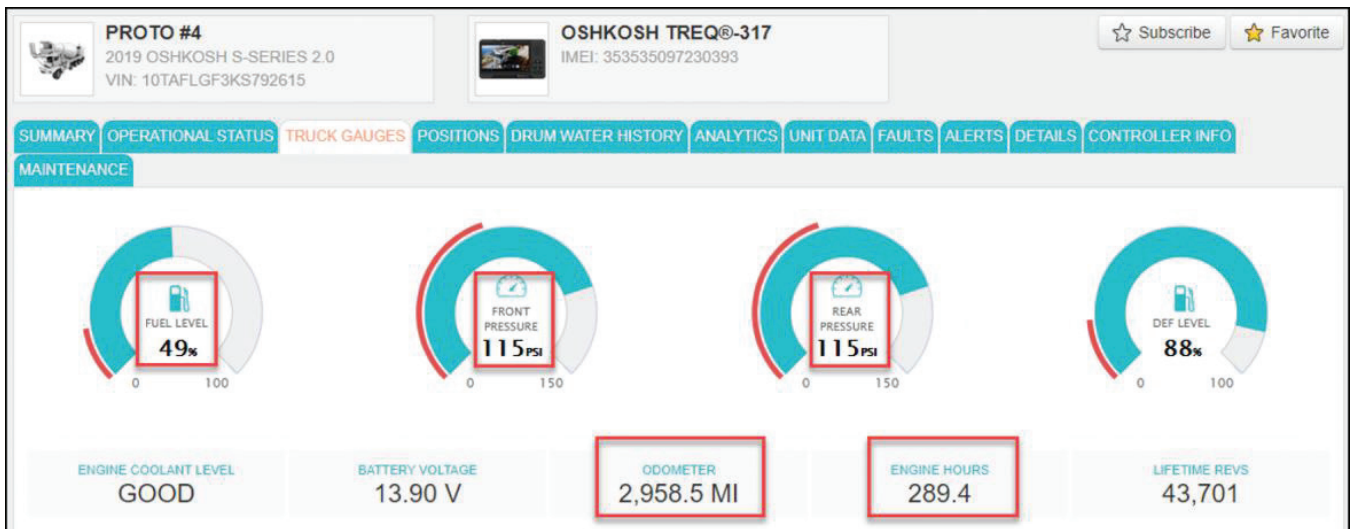


Figure 35

70. Click UNIT DATA tab and make sure a report named IGNON appears near top of REPORTS sub-tab with a DATE/TIME with the vehicle's ignition turned ON.

MAINTENANCE

REPORTS EXPORT

FROM: 5/8/2020 12:00:00 AM TIME ZONE: CENTRAL STANDARD TIME

« < 16 17 18 19 20 21 22 23 24 25 LOAD MORE

DATE/TIME	REPORT
5/14/2020 10:10:03 AM	IGNON
5/14/2020 10:10:03 AM	OPMODE
5/14/2020 10:10:03 AM	INFO
5/14/2020 10:10:01 AM	DM1
5/14/2020 10:09:59 AM	DM1
5/14/2020 10:09:13 AM	OPMODE

Figure 36

71. Click CONTROLLER INFO tab and make sure information for the following eleven parameters exist.

- VIN
- IMEI
- ICCID
- ENGINE SERIAL/SOFTWARE VERSION
- ABS SOFTWARE VERSION
- DISPLAY SOFTWARE VERSION
- FCM SOFTWARE VERSION
- RCM SOFTWARE VERSION
- TRANSMISSION SOFTWARE VERSION
- INSTRUMENT PANEL SOFTWARE VERSION
- ENGINE REFERENCE TORQUE

STATUS TOTALS TRUCK GAUGES POSITIONS DRUM WATER HISTORY ANALYTICS UNIT DATA FAULTS ! ALERTS DETAILS CONTROLLER INFO

MAINTENANCE 3 3 ACTIVITY

VIN	10TAF LGF1LS800616
IMEI	356052101257278
ICCID	89011702278389980719
ENGINE SERIAL/SOFTWARE VERSION	04384413*22503222*032019175002*61701841*G1*BII*
ABS SOFTWARE VERSION	2460030002*E454*
DISPLAY SOFTWARE VERSION	2.0.13
FCM SOFTWARE VERSION	7.4.5
RCM SOFTWARE VERSION	10.8
TRANSMISSION SOFTWARE VERSION	W19BCD_PC_8688*C19100087D88Z*
INSTRUMENT PANEL SOFTWARE VERSION	.4.4 - 3/12/20
ENGINE REFERENCE TORQUE	1991.42 FT-LB

Figure 37

## ClearSky™ Troubleshooting

1. Make sure TCU version number populates in overhead display ABOUT screen. If TCU version is not populated the TCU is not communicating.
  - a. Check for a solid red LED and flashing green LED on front of TCU. See Figure 38. No lit LEDs on front of TCU indicates no power to TCU.
  - b. Make sure TCU connectors are fully seated and there are no bent or damaged pins.
2. Make sure GPS antenna and cellular cables are connected correctly.

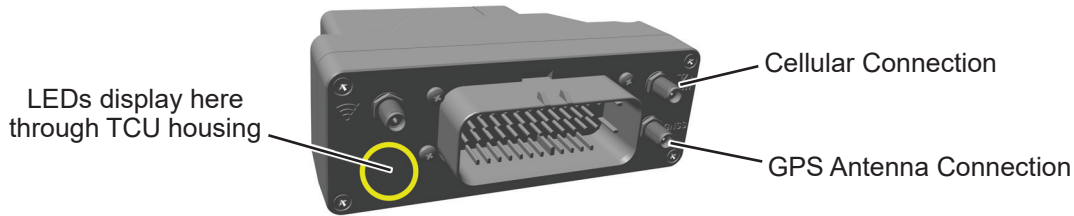


Figure 38

3. Turn vehicle's battery disconnect switch OFF and wait until LEDs on front of TCU turn off, the TCU has an internal battery which can take up to 3 hours to fully drain before LEDs go out.
4. Turn vehicle's battery disconnect switch ON.
5. Turn vehicle ignition switch ON and recheck if TCU is operating and populates the version number in overhead display ABOUT screen.
6. Contact S-Series service if these troubleshooting steps do not correct TCU operation.

### Continuous Improvement:

The change included in this document is part of the McNeilus Continuous Improvement Process.

*McNeilus's quality policy is providing customer satisfaction through innovative products, dedicated service, and a constant focus on continuous improvement.*

**McNeilus**

(888) 686-7278

[www.streetsmartparts.com](http://www.streetsmartparts.com)