

**SIB 64 05 25**

2025-05-15

**HVAC FLAP LINKAGE NOT FULLY CONNECTED**

This Service Information Bulletin (Revision #2) replaces SI B64 05 25 **dated April 2025**.

**What's New** (Specific text highlighted):

- Correction and Procedure Section updated

<input type="checkbox"/>	THIS REPAIR IS MOBILE FRIENDLY
<input type="checkbox"/>	THIS REPAIR IS REMOTE SOFTWARE UPGRADE (RSU) FRIENDLY

**MODEL**

<b>E-Series</b>	<b>Model Description</b>	<b>Production Date</b>
G45	X3 Sports Activity Vehicle	Vehicles produced up to January 2025

**SITUATION**

Customer states that the output air from one of the vehicle vent assemblies doesn't match the desired temperature, nor change from Hot/Cold.

**CAUSE**

The air flap linkage may not be fully locked into the air mixing flap.

**CORRECTION**

Check that the linkage has not come loose from the flap in the heating, ventilation, and air conditioning (HVAC) system.

This can occur to ANY of the flaps in the HVAC system.

See attached video for one example

[BV64 02 25 G45 Flap Linkage](#)

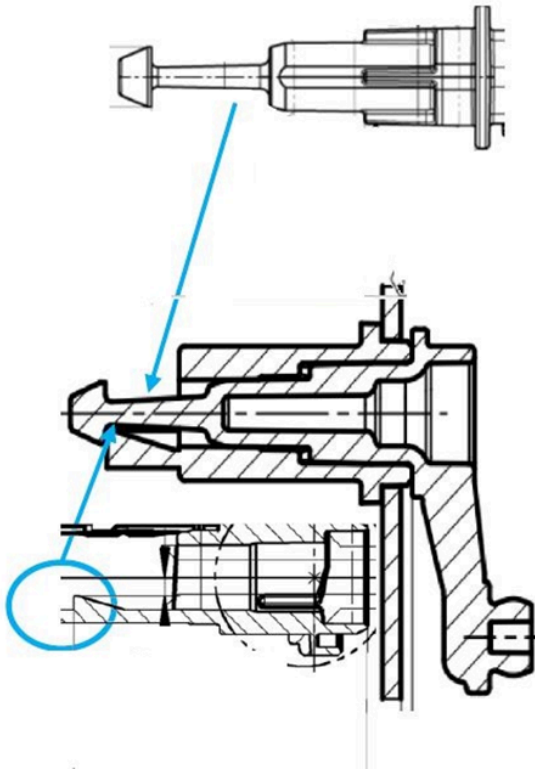

There is a push-in end on the linkage that can be reinserted into the flap and fully seated.



Check that the linkage has not come loose from the HVAC flap for the zone that is malfunctioning.

There is a white plastic mechanism that connects the black linkage arm and the HVAC flap assembly.

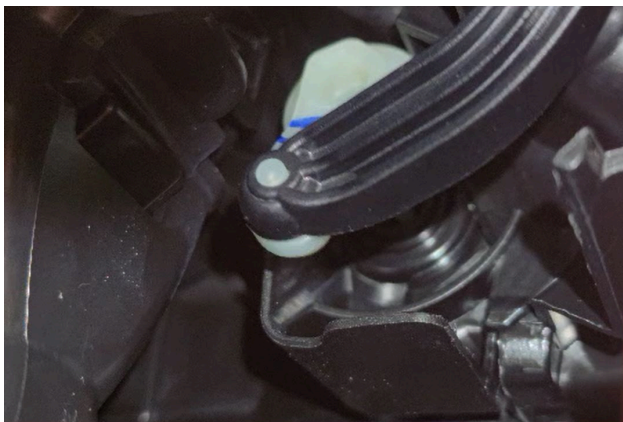

To test if the mechanism is fully seated into the HVAC flap assembly, perform a wiggle test of the white plastic (in/out). Here you can see the white plastic mechanism has backed out of the HVAC case and is not locked into the flap.

This can occur to ANY of the flaps in the HVAC system.

See video attached to the bulletin for one example.

If using a borescope to inspect if the flap is fully locked into the linkage, you can see the White plastic mechanism push pin mushroom shaped end must engage into the flap by being pushed in until it fully goes past the plastic flap ramp. The pictures below show fully locked in vs not fully locked.

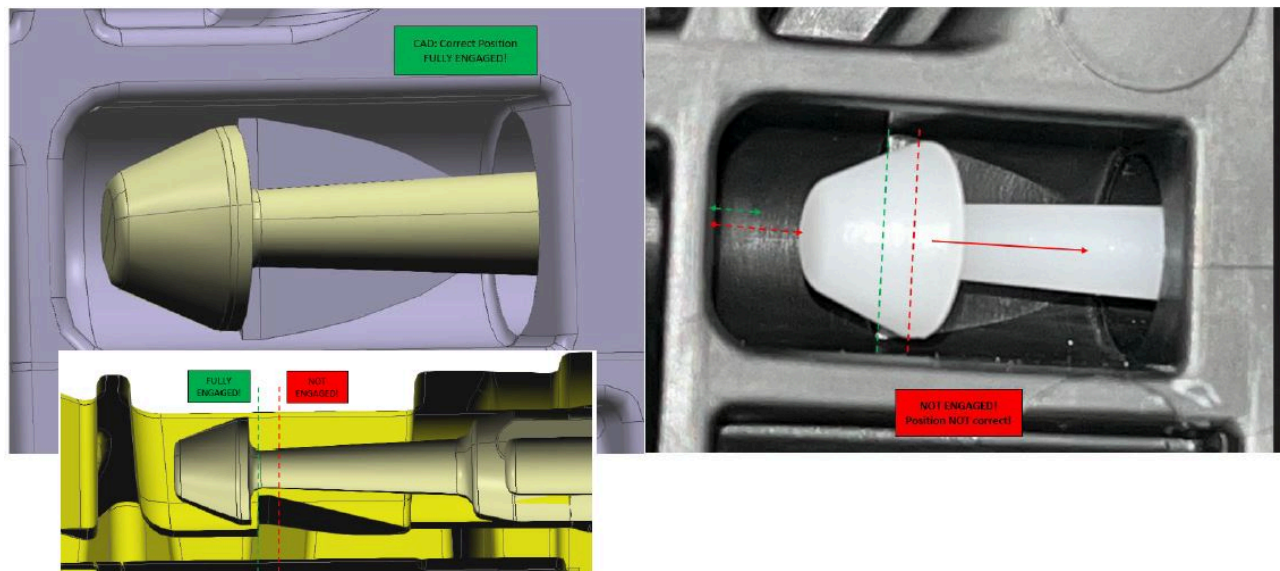

## PROCEDURE

See attachment for the Procedure.

Check that the linkage has not come loose from the HVAC flap. This can occur to ANY of the flaps in the HVAC system.

There is a white plastic mechanism that connects the black linkage arms and the HVAC flap assembly. To test if the mechanism is fully seated into the HVAC flap assembly perform a wiggle test of the white plastic (in/out).

There is a push in end on the linkage that can be reinserted into the HVAC flap and fully seated. The white plastic mechanism push pin can be reinserted into the HVAC flap and fully seated.

**Make sure to push in until you can feel the white plastic mechanism push pin mushroom shaped end engage into the flap ramp.**

**The flap and linkage may be out of time and only snap in one way.**

Move flap or use BCP\_SP21 test plan to move linkage to align.

The test plans can be found in Procedure Heating and air conditioning functions:

- Move flap motors to installation position (**ABL-DIT-AS6450\_SP21\_KLAP\_MOTOR\_MONTAGEPO**) This is the middle of travel flap setting.
- Flap motors, calibration run (**ABL-DIT-AS6450\_SP21\_KLAP\_MOTOR\_EICHLAUF**)

## CLAIM INFORMATION

This Service Information Bulletin provides technical, diagnostic and/or repair-related information.

Damage and/or issues caused by outside influences are not covered under the BMW Limited Warranties.

### Eligible and Covered Work/Repairs

Repairs that address a verified defect in materials and/or workmanship are covered under the terms of the BMW New Vehicle Limited Warranty for Passenger Cars and Light Trucks.

To submit a claim, please following the established and applicable warranty policy and procedures  
Copyright ©2025 BMW of North America, Inc.

Refer to AIR for the claim-related line item's Repair Code. For the corresponding repair that was performed, obtain the corresponding labor operation codes and their flat rate unit (FRU) allowance(s), including the diagnosis\* that applies.

Only one Main labor operation code can be claimed per repair visit.

### BMW Group's AIR Application Resource for Flat Rate Labor Operation Codes

To obtain the corresponding flat rate unit (FRU) allowance information from the BMW Group AIR application resource, start by entering the Chassis Number (last seven (7) characters of the VIN), and click on the "Search" icon. If the "Vehicle Selection" window displays two or more model possible vehicle choices, select the applicable Model, or enter the full VIN (17 characters) instead to proceed. Click on the "Flat Rate Units" button and enter a flat rate labor operation code number "without spaces" in the field to the right, click on the "Search" icon to display the corresponding listing of "Flat rate unit group details" that are available and their corresponding FRU allowances.

(\*) Based on which one applies to your center, please refer to **SI B01 01 20** or **B01 07 20** for the applicable procedure for documenting, claiming, and explaining, on the RO and in the claim comments, your diagnosis work time (WT), job/repair work time (WT), and the vehicle repairs your center performed, unless otherwise required by State law.

### FEEDBACK REGARDING THIS BULLETIN

Technical Feedback	To submit feedback for the technical topic of this bulletin: Submit your feedback in the rating box at the top of this bulletin
Warranty Feedback	To submit feedback for the CLAIMS section of this bulletin: Submit an IDS ticket to the Warranty Department, or use the chat available in the Warranty Documentation Portal
Parts Feedback	To submit feedback for the PARTS section of this bulletin: Submit an IDS ticket to the Parts Department

#### Supporting Materials

[picture\\_as\\_pdf Attachment B64 05 25 4\\_25.pdf](#)

#### Videos

[64 02 25](#)



# G45 HVAC: Air Vent Flaps/Kinematic & Stepper Motor Master Info.

B64 05 25 Attachment

March 2025

## G45 HVAC: Complete Assembly Overview

- OVERVIEW CHART
- Air Vent Flaps/Kinematic (+ push pin) Detailed Information
- Stepper Motor Control Detailed Information

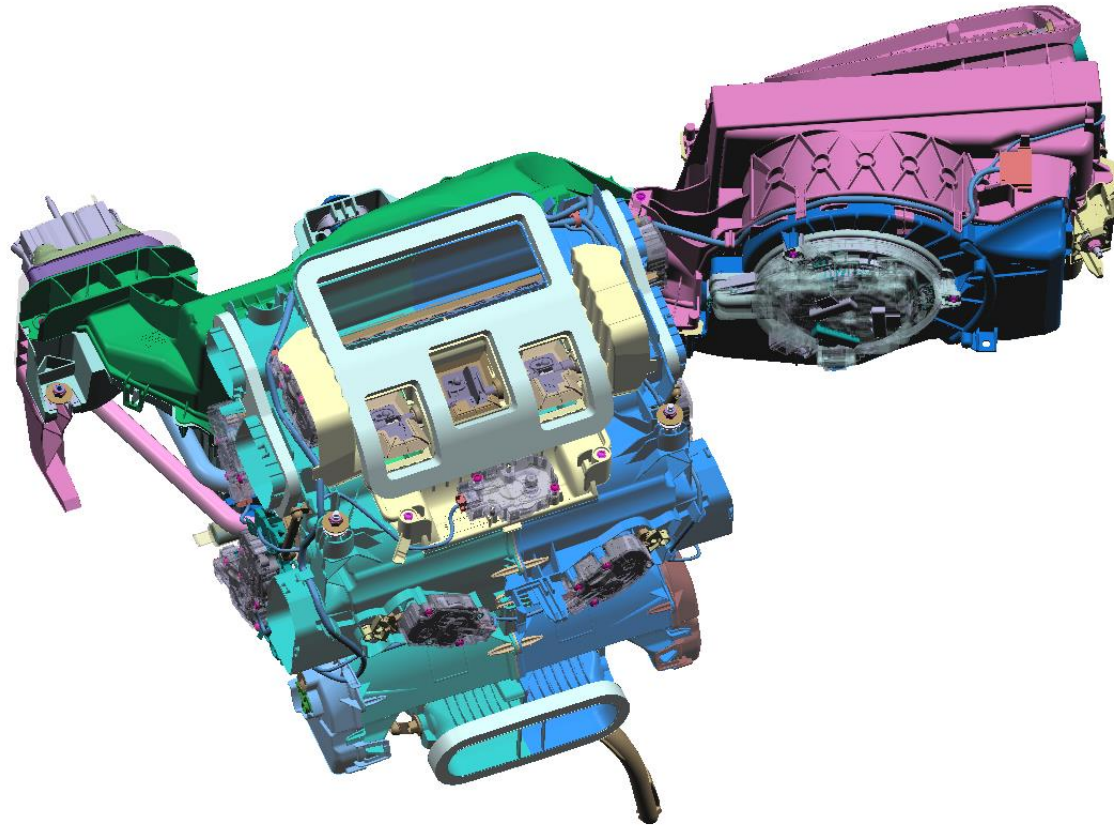

# G45 HVAC: Air Vent Flaps/Kinematic & Stepper Motor Master Info.

## OVERVIEW: Air Vent Flaps/Kinematic & Stepper Motor Control Chart

AIR VENT <u>FLAPS</u>			STEPPER MOTOR CONTROL INFORMATION		
Vent Flap #	Vent <u>Flap</u> Description	Vent Flap Visibility ( <u>for push pin</u> )	Motor Position #	Electrical ID	Motor Control Desc
1	Fresh Air Flap	Easily Visible: Just inside of HVAC	13	M 16 (Shared) ←	Fresh Air / Recirculated Air Distribution
2	Recirculated Air Flaps x2 (connected)	Easily Visible: Just inside of HVAC	13	M 16 (Shared) ←	Fresh Air / Recirculated Air Distribution
3	Defrost Air Flap	Easily Visible: Just inside of HVAC	10	M 61	Defrost Air Distribution
4 A	Front Cold Temp. Mixing Flap LEFT	Difficult: Boroscope through open Flap #3	2	▶ M 23 (Shared)	Front Temperature Mixing LEFT
4 B	Front Cold Temp. Mixing Flap RIGHT	Difficult: Boroscope through open Flap #3	9	M 83 (Shared) ←	Front Temperature Mixing RIGHT
5 A	Front <u>Warm</u> Temp. Mixing Flap LEFT	Difficult: Boroscope through open Flaps #7	2	▶ M 23 (Shared)	Front Temperature Mixing LEFT
5 B	Front <u>Warm</u> Temp. Mixing Flap RIGHT	Difficult: Boroscope through open Flaps #7	9	M 83 (Shared) ←	Front Temperature Mixing RIGHT
6 A	Front Footwell Air Flap LEFT	Easily Visible: Just inside of HVAC	5	M 21	Front Footwell Air Distribution LEFT
6 B	Front Footwell Air Flap RIGHT	Easily Visible: Just inside of HVAC	4	M 7	Front Footwell Air Distribution RIGHT
7 A	Front Center Vent Air Flap LEFT	Easily Visible: Just inside of HVAC	7	M 20	Front Center Vent Air Distribution LEFT
7 B	Front Center Vent Air Flap RIGHT	Easily Visible: Just inside of HVAC	12	M 22	Front Center Vent Air Distribution RIGHT
8 A	Front Side Vent Air Flap LEFT	Easily Visible: Just inside of HVAC	3	M 020	Front Side Vent Air Distribution LEFT
8 B	Front Side Vent Air Flap RIGHT	Easily Visible: Just inside of HVAC	11	M 022	Front Side Vent Air Distribution RIGHT
9	Rear Upper Vent Flap (Center Console)	Easily Visible: Just inside of HVAC	1	M 084 (Shared) ←	REAR Air Distribution
10	Rear Cold Temp. Mixing Flap	Difficult: Boroscope through open Flap #9	8	▶ M 024 (Shared)	REAR Temperature Mixing
11	Rear Warm Temp. Mixing Flap	Other: No direct push pin (tied to Flap #10)	8	▶ M 024 (Shared)	REAR Temperature Mixing
12	Rear Footwell Air Flaps L/R x2 (connected)	Easily Visible: Just inside of HVAC (D.S)	1	M 084 (Shared) ←	REAR Air Distribution
13	Indirect Air Flap	N/A: Different connection type (no push pin)	6	M 197	Indirect Air Distribution

Please reference the FLAP diagram & STEPPER MOTOR control locations diagrams on the following pages.

# G45 HVAC: Air Vent Flaps/Kinematic & Stepper Motor Master Info.

## FLAPS / Kinematic Diagram Details (Overview)

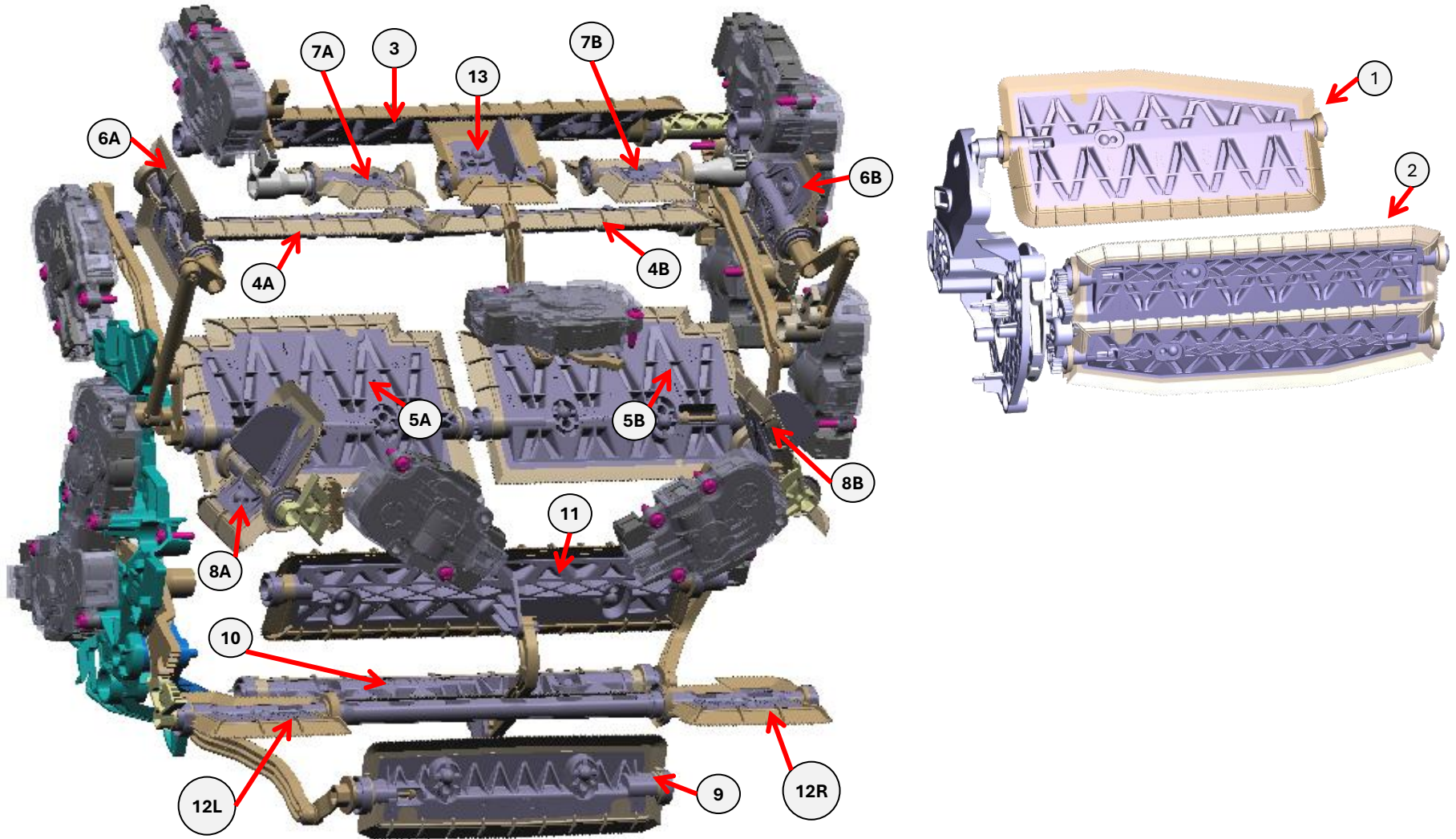

# G45 HVAC: Air Vent Flaps/Kinematic & Stepper Motor Master Info.

## Stepper Motor Control Locations Diagram (OVERVIEW)

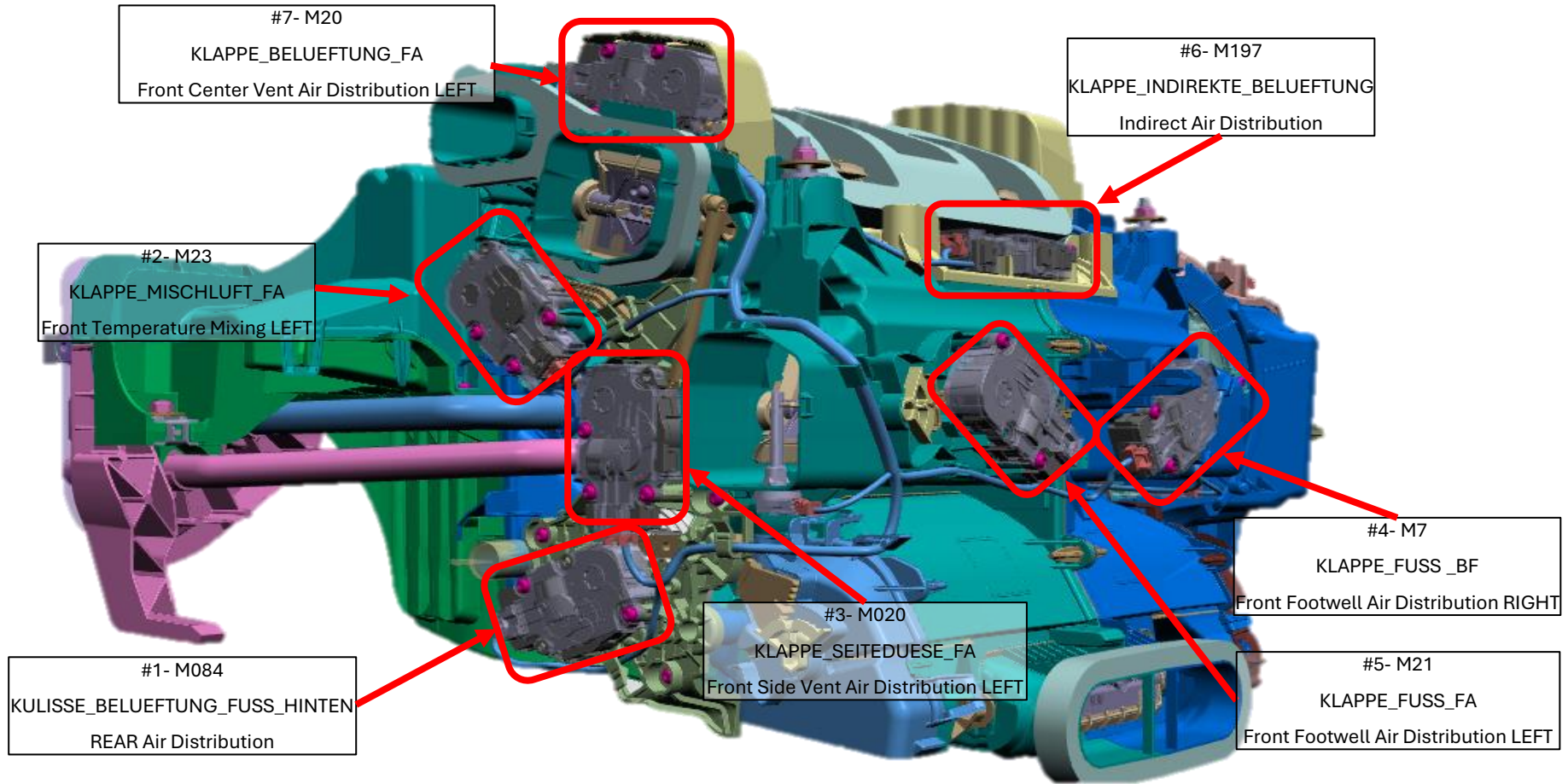

**(LHD: Left Side VIEW)**

# G45 HVAC: Air Vent Flaps/Kinematic & Stepper Motor Master Info.

## Stepper Motor Control Locations Diagram (OVERVIEW)

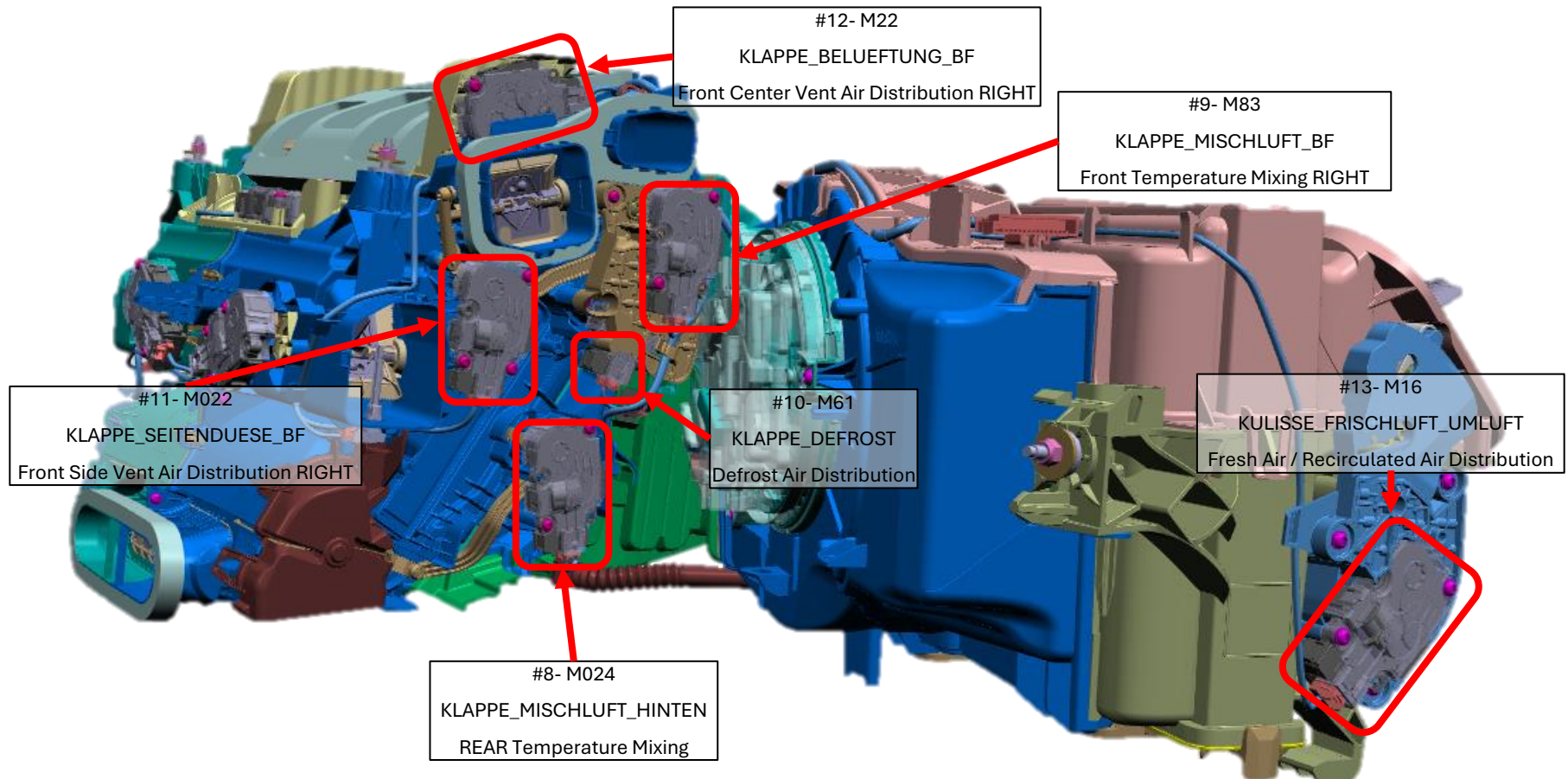

**(LHD: Right Side VIEW)**

# G45 HVAC: Air Vent Flaps/Kinematic & Stepper Motor Master Info.

## FLAP #1: Fresh Air Flap

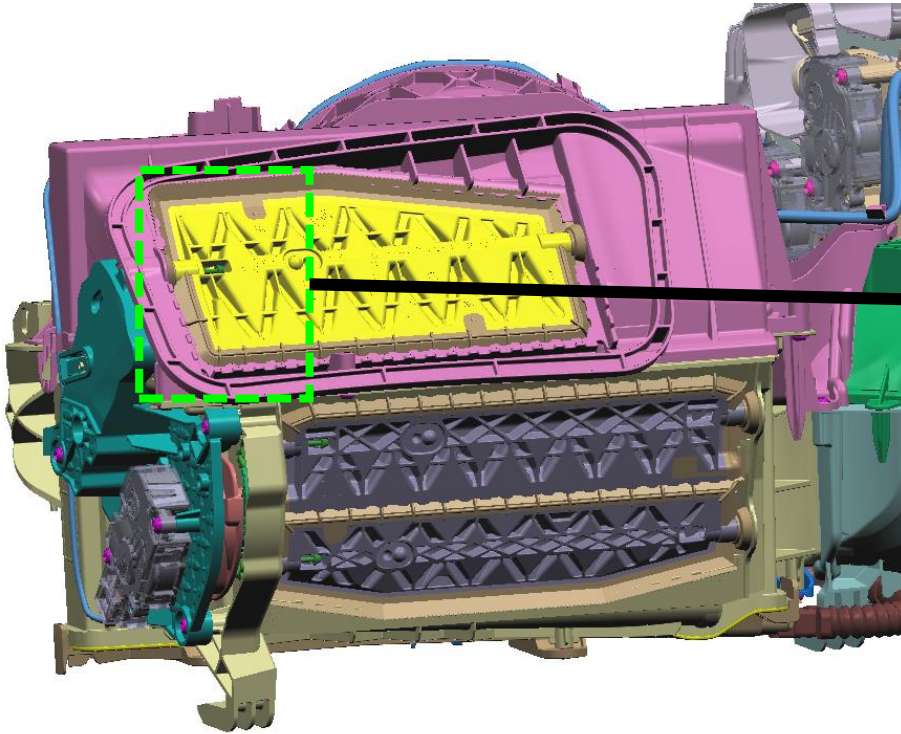

# G45 HVAC: Air Vent Flaps/Kinematic & Stepper Motor Master Info.

## FLAP #2: Recirculated Air Flaps x2 (connected)

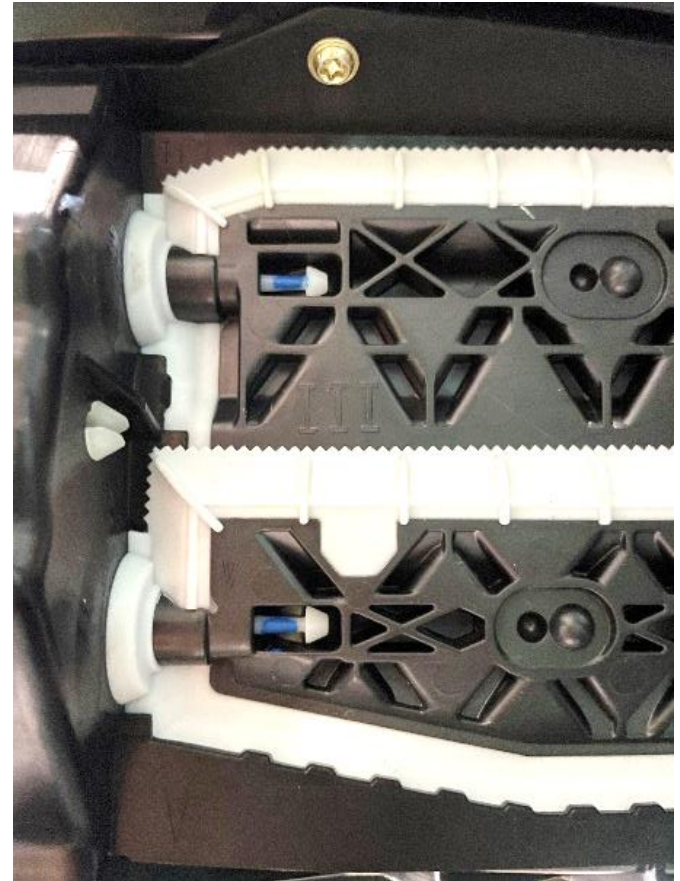
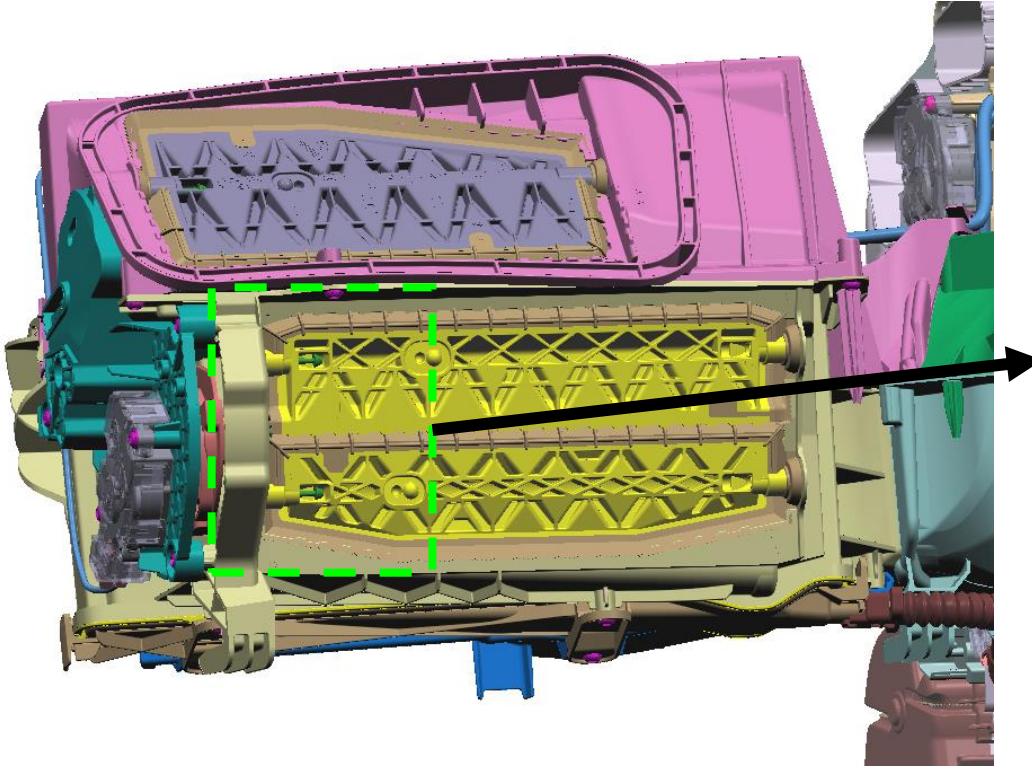

TWO Push Pins!

# G45 HVAC: Air Vent Flaps/Kinematic & Stepper Motor Master Info.

## FLAP #1 & FLAP #2 Complete Kinematics Overview

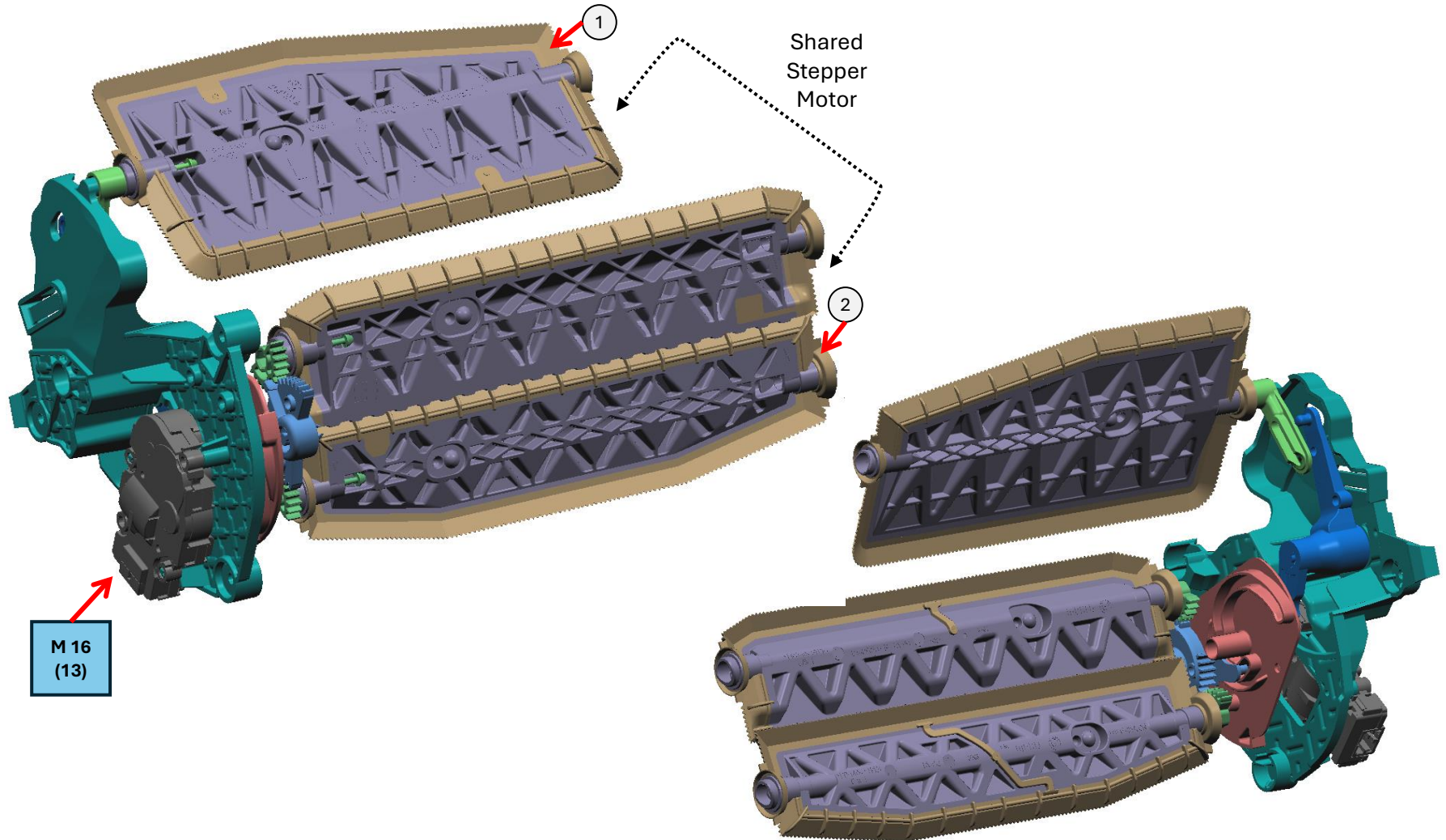

# G45 HVAC: Air Vent Flaps/Kinematic & Stepper Motor Master Info.

## FLAP #3: Defrost Air Flap

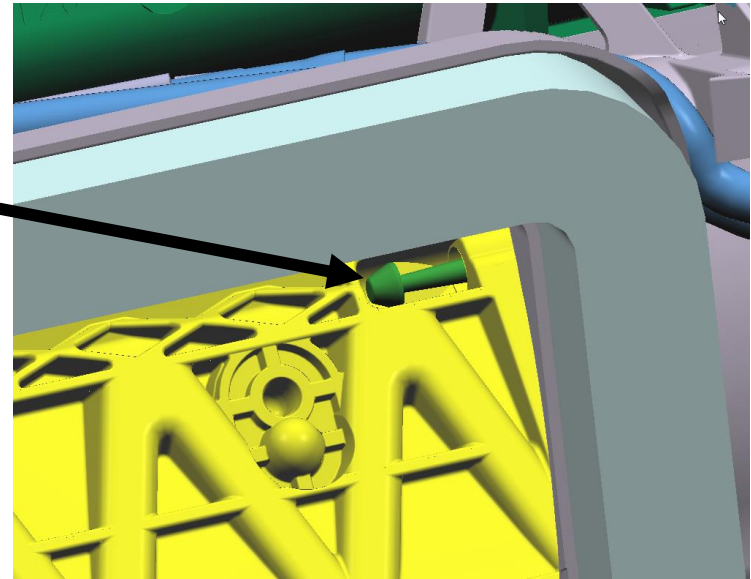
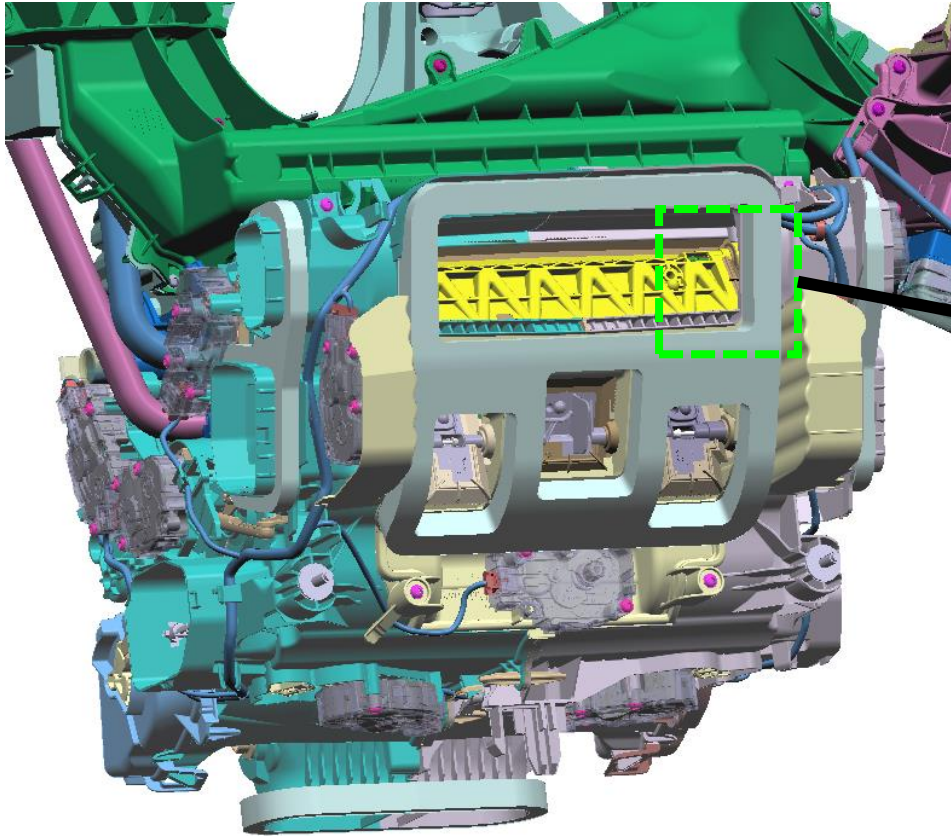

# G45 HVAC: Air Vent Flaps/Kinematic & Stepper Motor Master Info.

## FLAP #3 Kinematics Overview

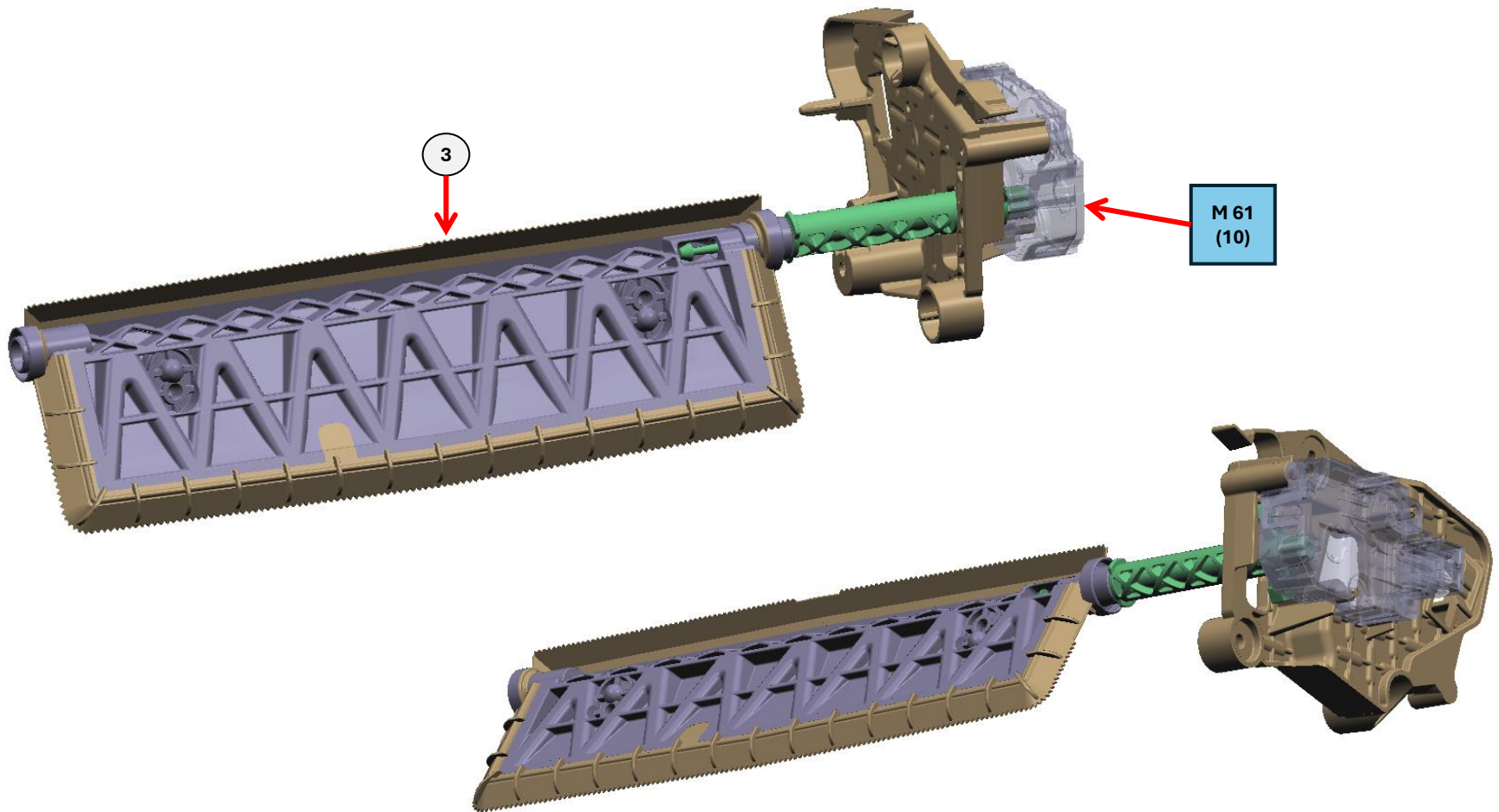

# G45 HVAC: Air Vent Flaps/Kinematic & Stepper Motor Master Info.

## FLAP #4A/4B: Front Cold Temp. Mixing Flap Right (Mirrored Right to Left)

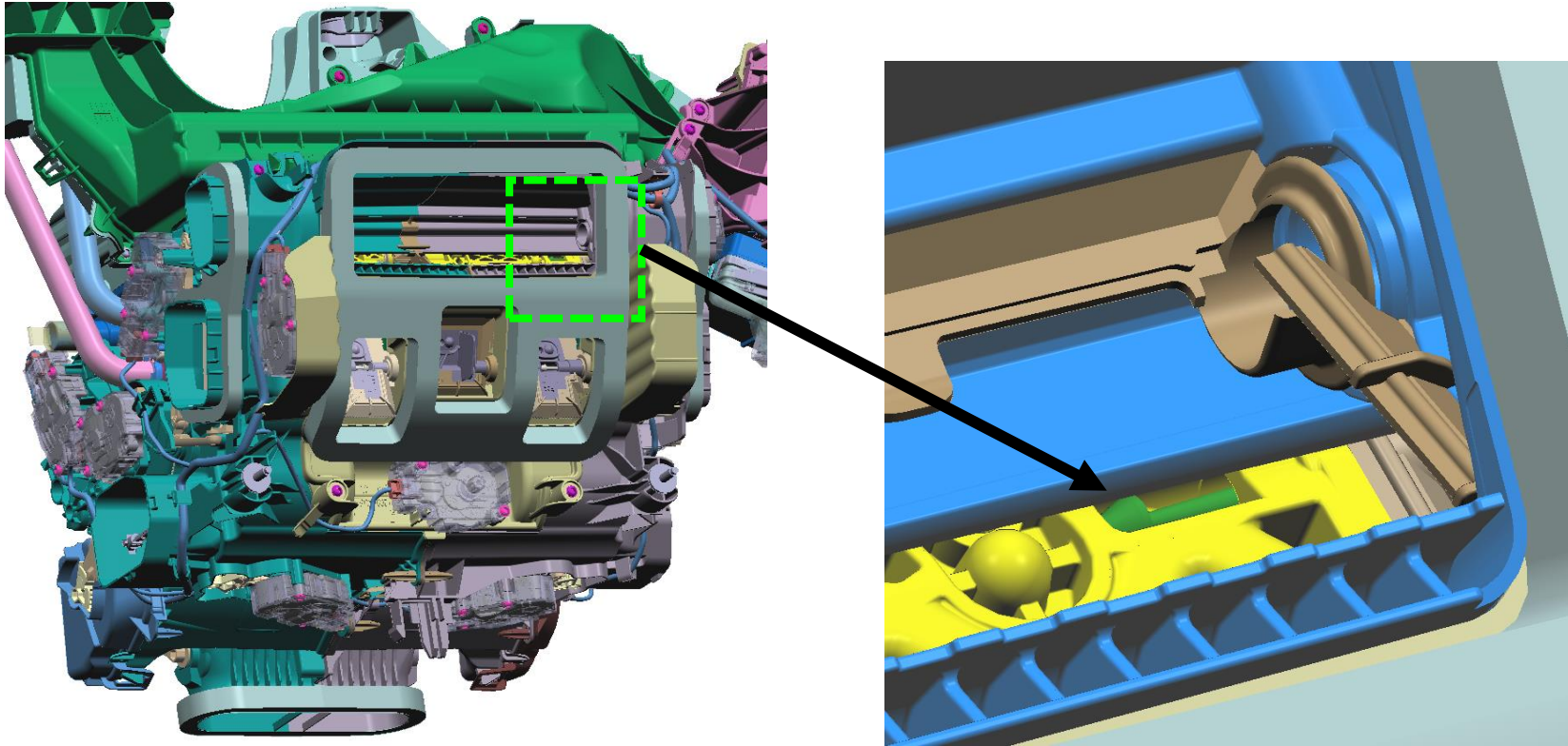

4B shown. #3 Defrost Air Flap removed from CAD image for easier visibility

TWO Push Pins (one on LEFT side flap & one on RIGHT side flap)!

# G45 HVAC: Air Vent Flaps/Kinematic & Stepper Motor Master Info.

## FLAP #4A/4B FLAP Kinematics Overview (Highlighted Yellow)

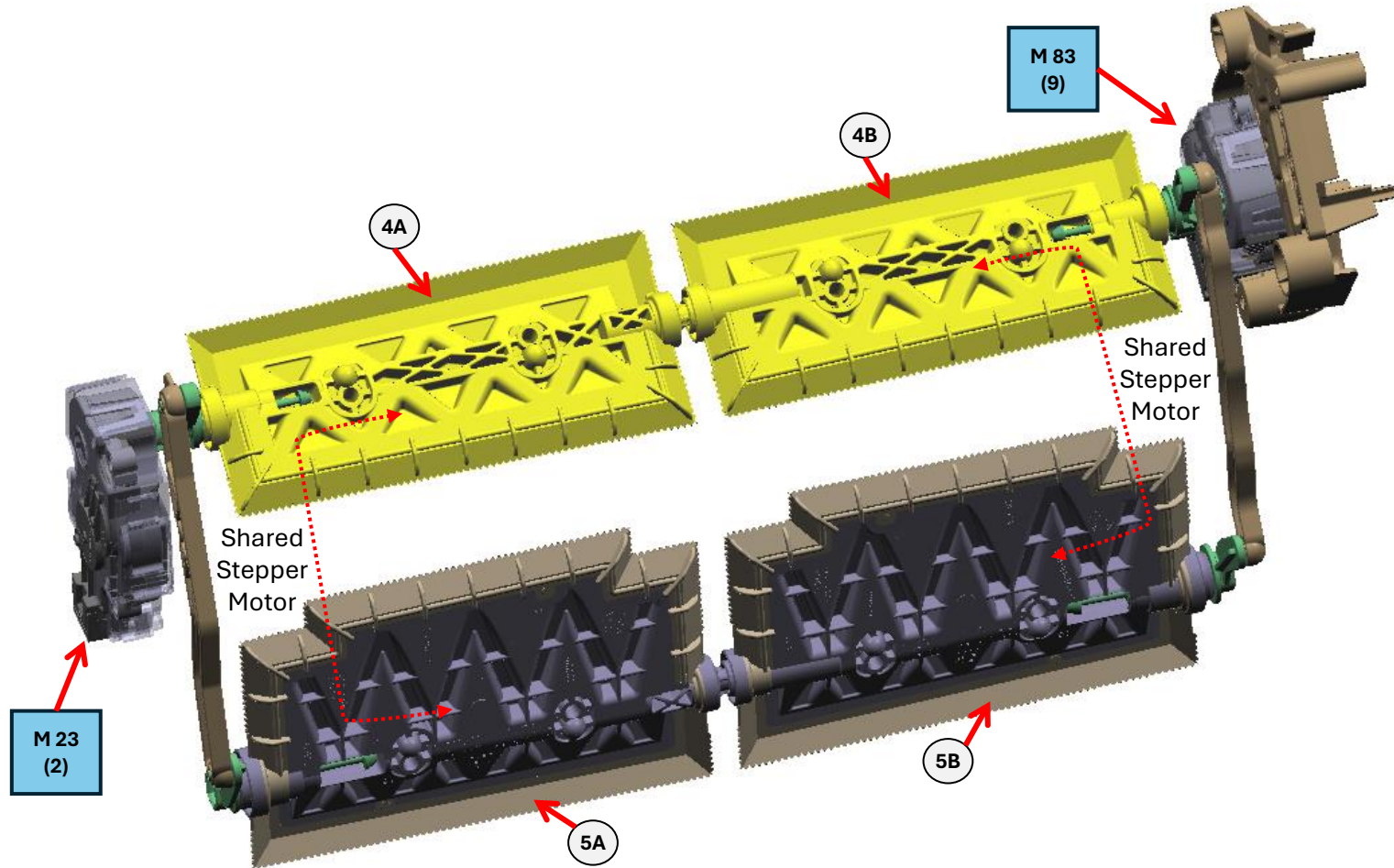

# G45 HVAC: Air Vent Flaps/Kinematic & Stepper Motor Master Info.

## FLAP #5A/5B: Front Warm Temp. Mixing Flap Right (Mirrored Right to Left)

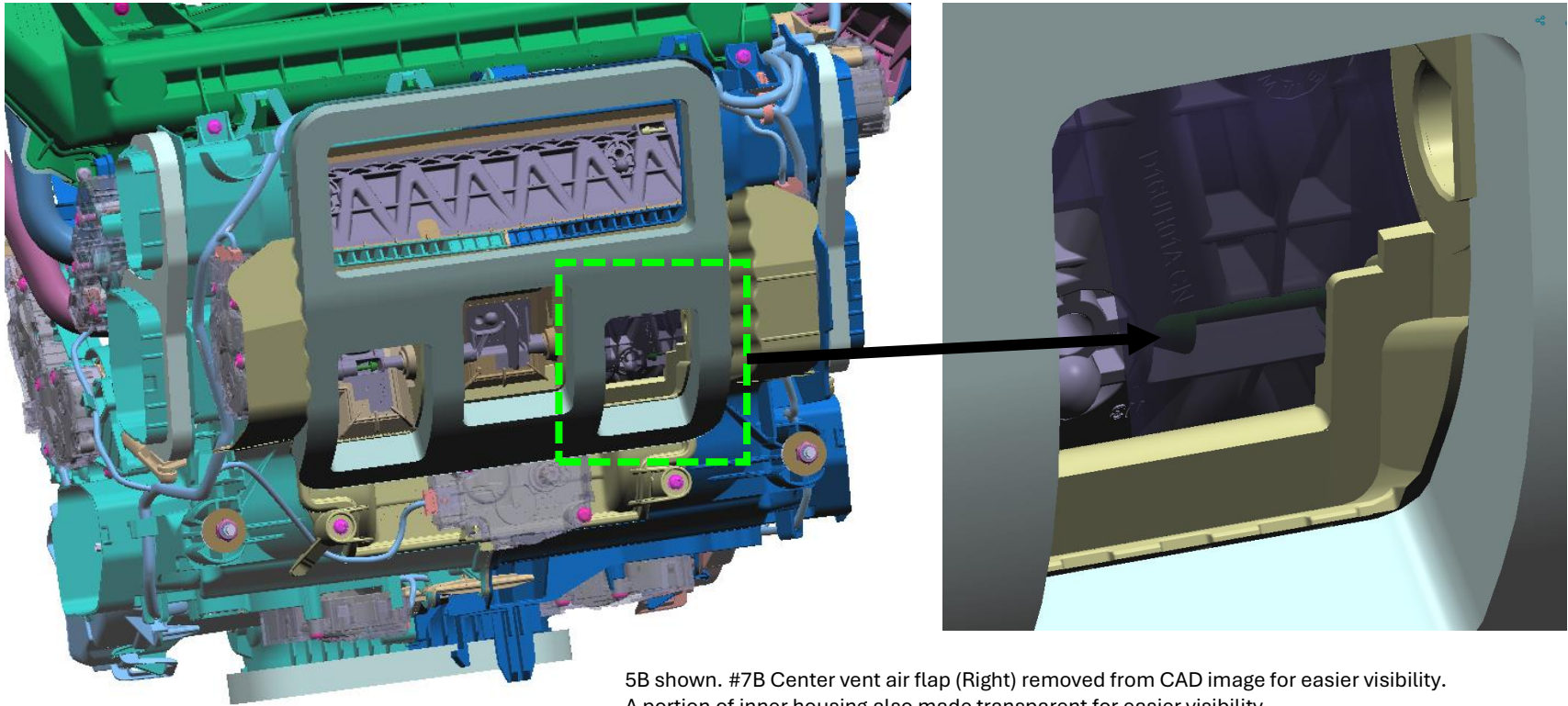

5B shown. #7B Center vent air flap (Right) removed from CAD image for easier visibility.  
A portion of inner housing also made transparent for easier visibility.

**TWO Push Pins (one on LEFT side flap & one on RIGHT side flap)!**

# G45 HVAC: Air Vent Flaps/Kinematic & Stepper Motor Master Info.

## FLAP #5A/5B FLAP Kinematics Overview (Highlighted Yellow)

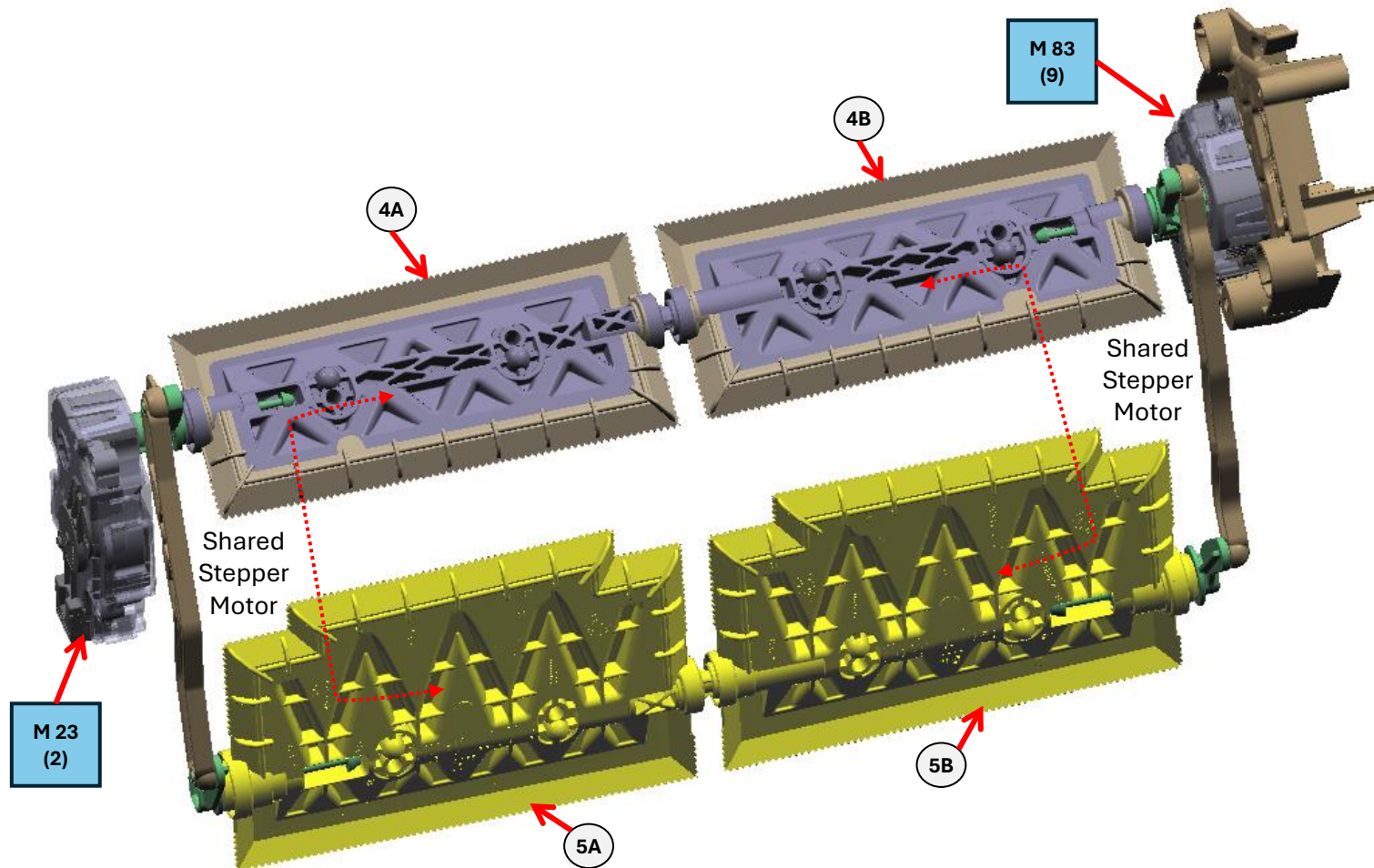

# G45 HVAC: Air Vent Flaps/Kinematic & Stepper Motor Master Info.

## FLAP #6A/6B: Front Footwell Air Flap LEFT (Mirrored Left to Right)

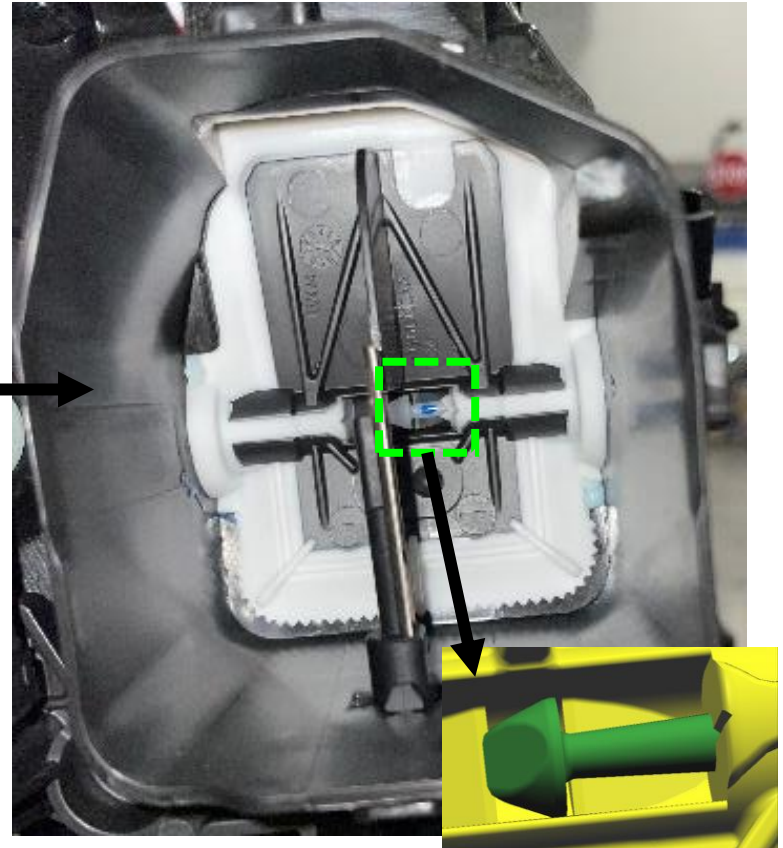
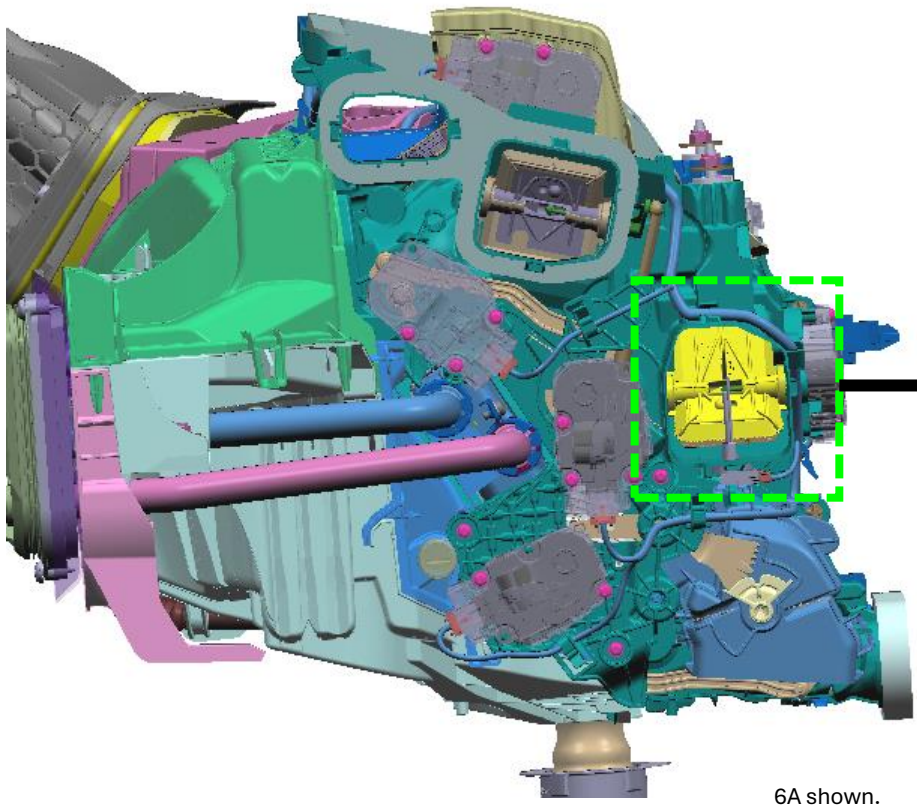

TWO Push Pins (one on LEFT side flap & one on RIGHT side flap)!

# G45 HVAC: Air Vent Flaps/Kinematic & Stepper Motor Master Info.

## FLAP #6A/6B FLAP Kinematics Overview

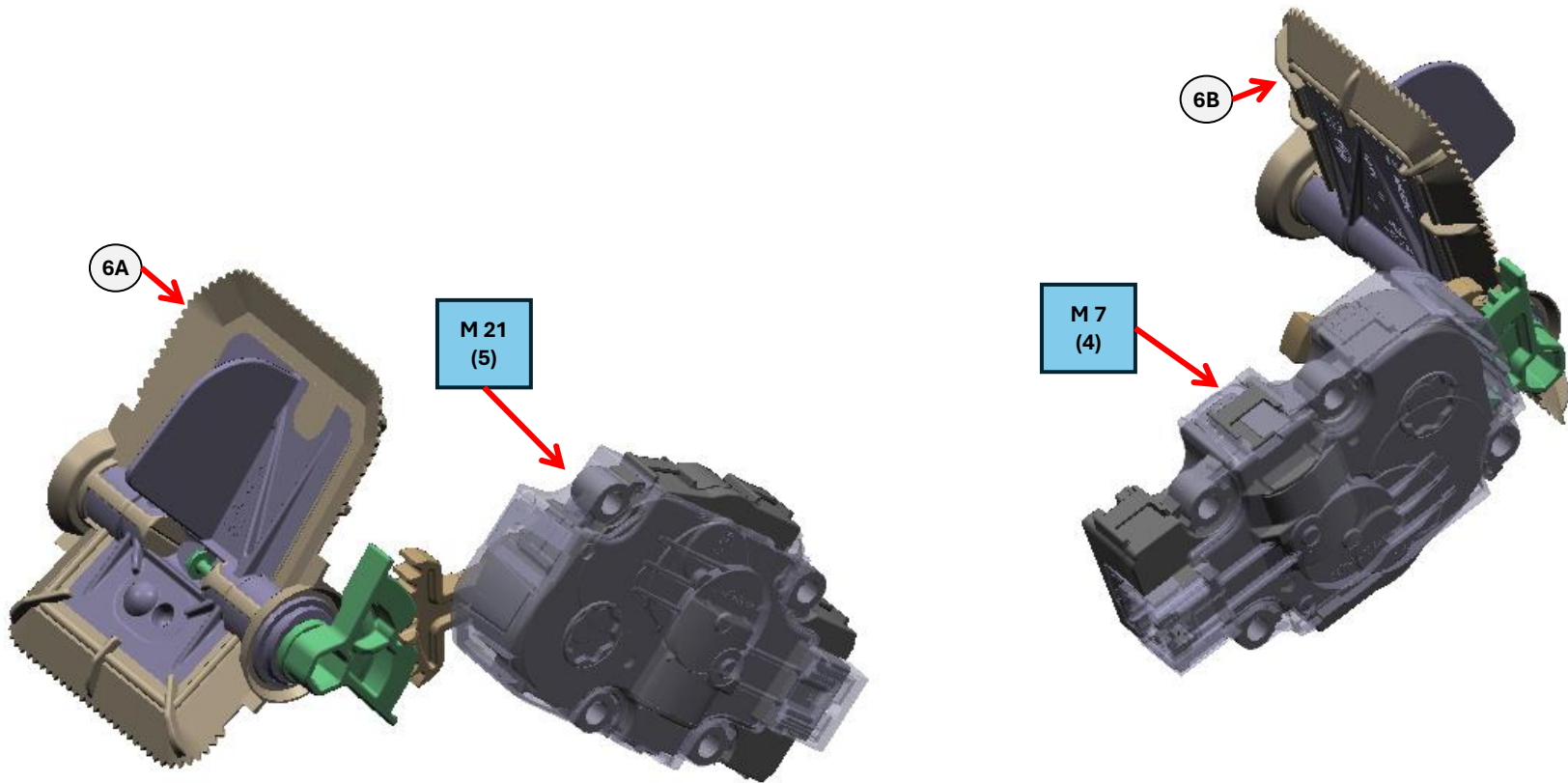

# G45 HVAC: Air Vent Flaps/Kinematic & Stepper Motor Master Info.

## FLAP #7A/7B: Front Center Vent Air Flap Right (Mirrored Right to Left)

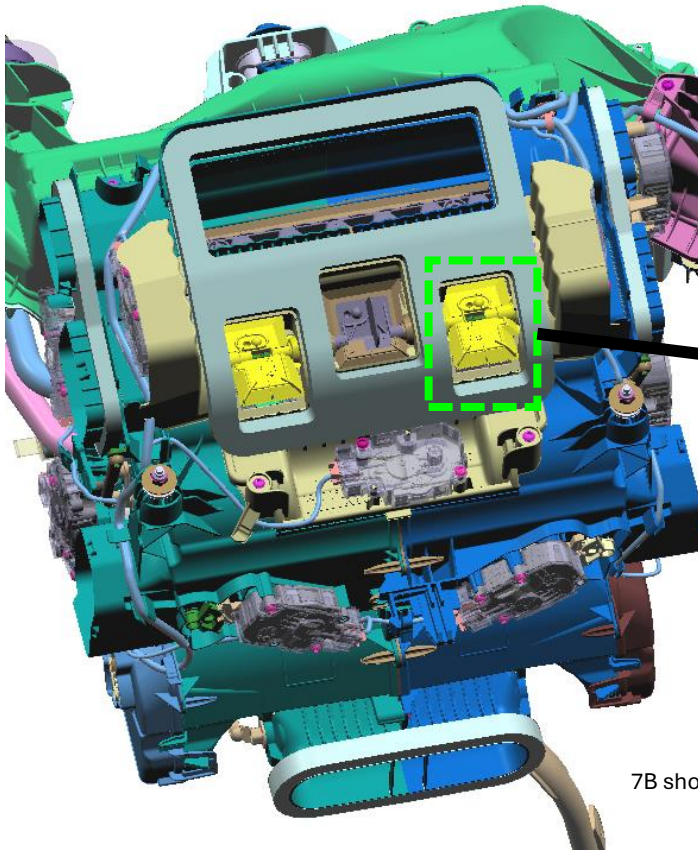

7B shown.

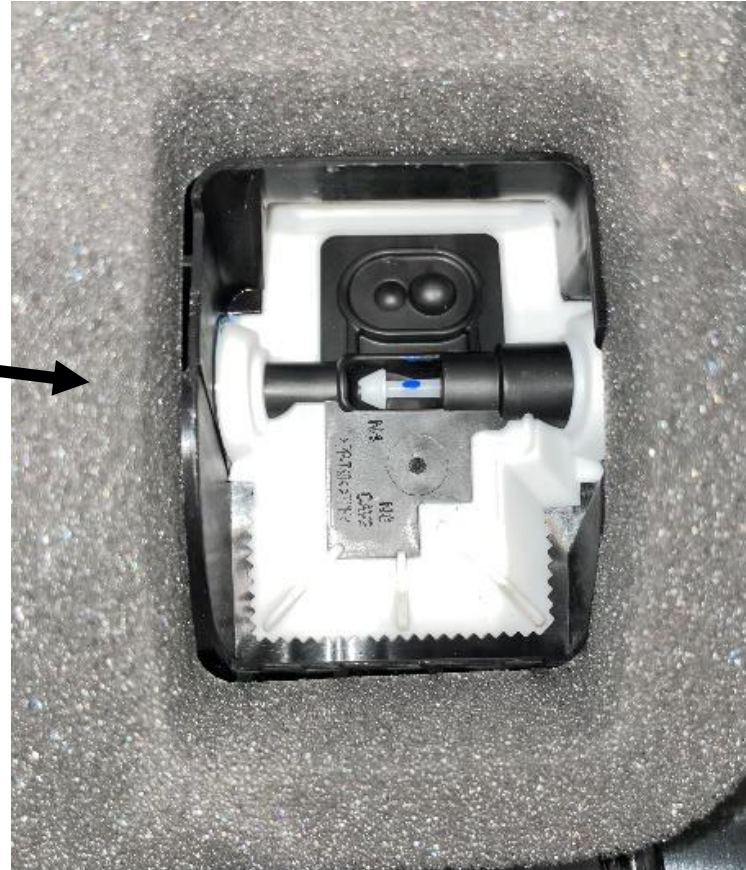

TWO Push Pins (one on LEFT side flap & one on RIGHT side flap)!

# G45 HVAC: Air Vent Flaps/Kinematic & Stepper Motor Master Info.

## FLAP #7A/7B FLAP Kinematics Overview

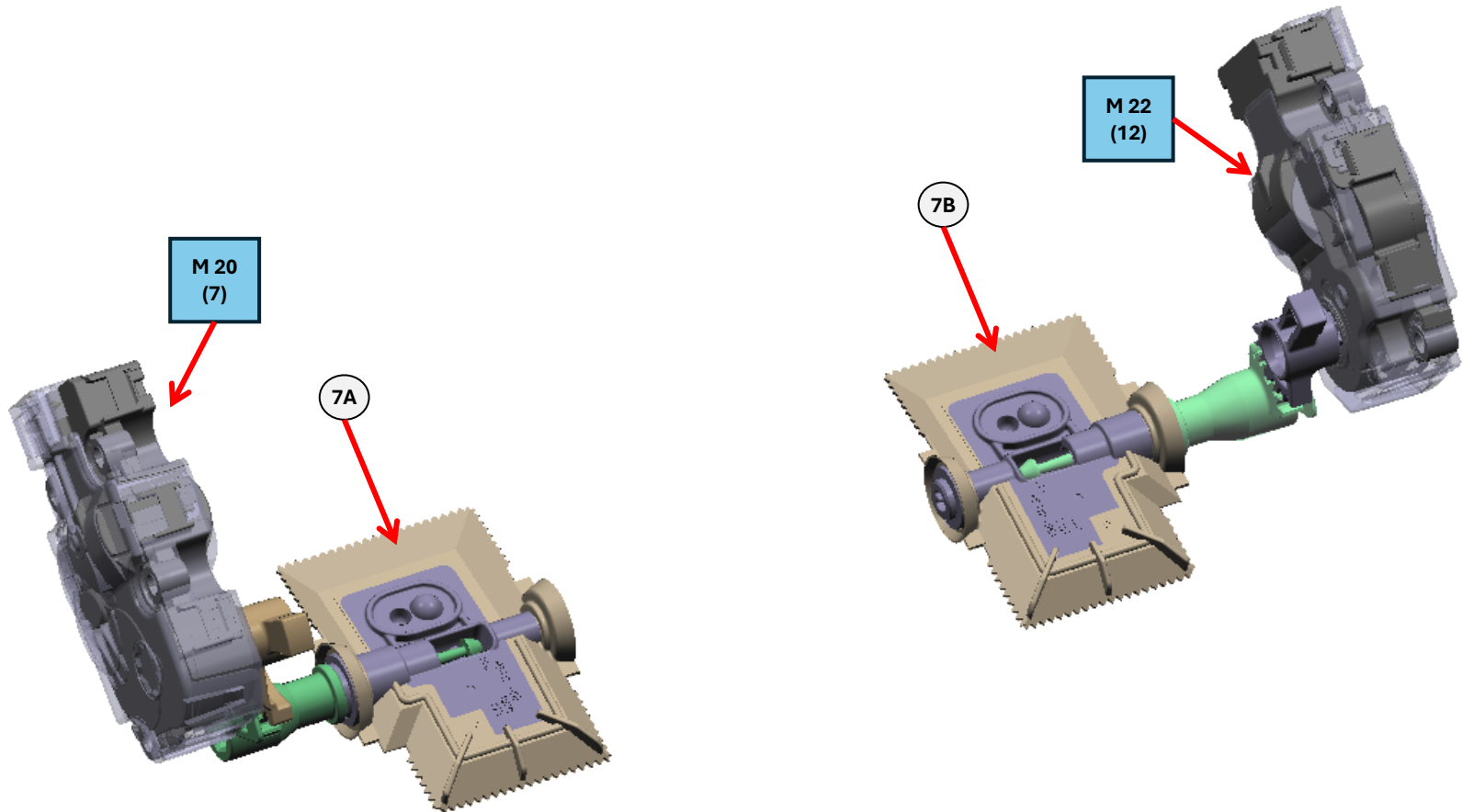

# G45 HVAC: Air Vent Flaps/Kinematic & Stepper Motor Master Info.

## FLAP #8A/8B: Front Side Vent Air Flap LEFT (Mirrored Left to Right)

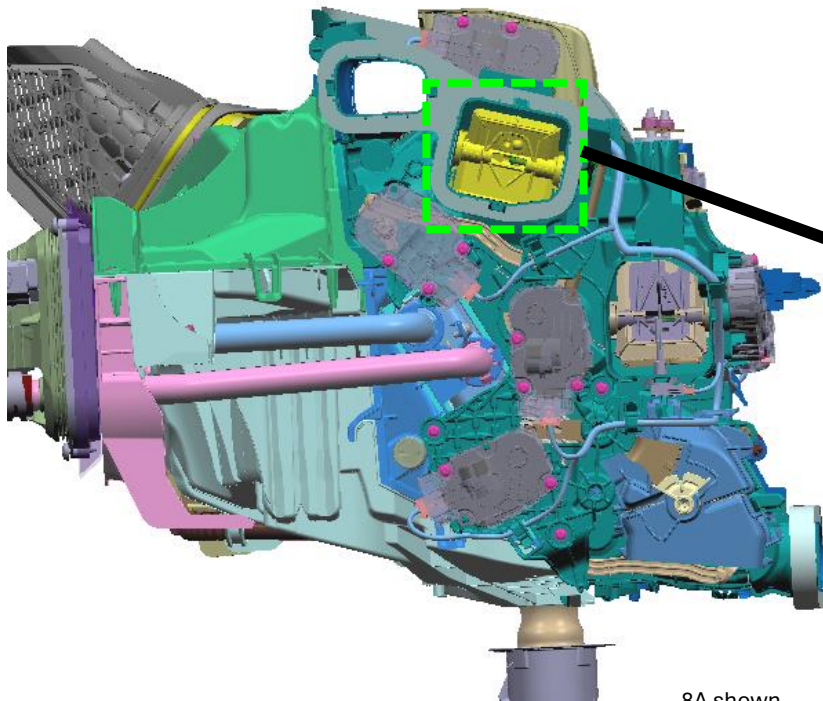

8A shown.

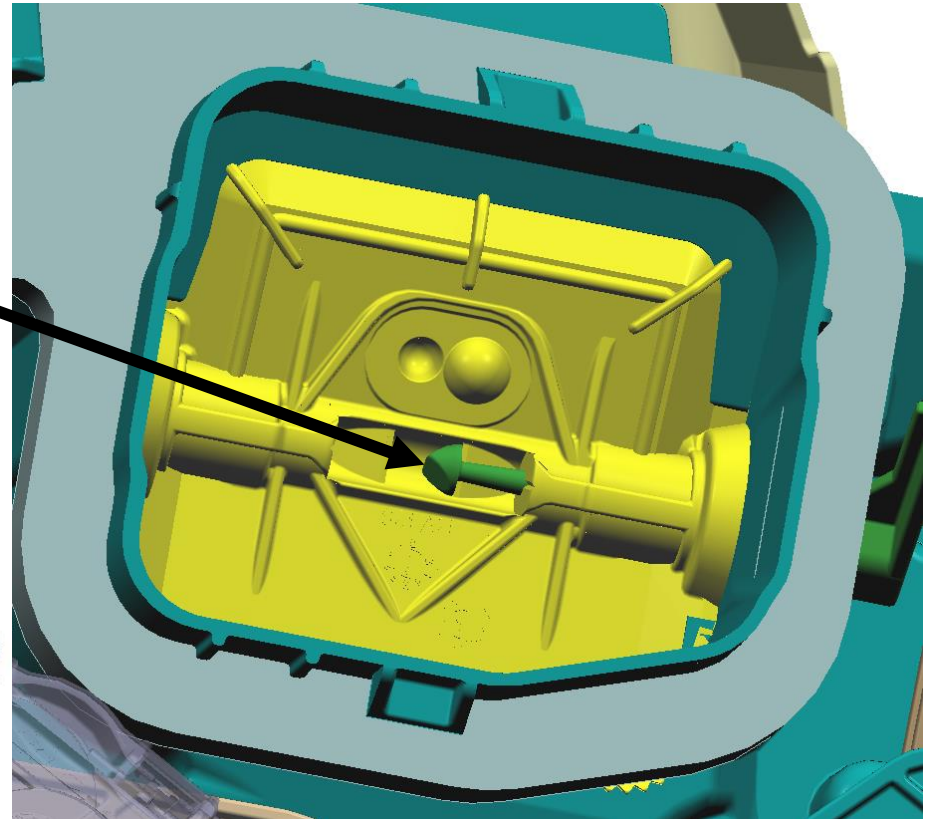

TWO Push Pins (one on LEFT side flap & one on RIGHT side flap)!

# G45 HVAC: Air Vent Flaps/Kinematic & Stepper Motor Master Info.

## FLAP #8A/8B FLAP Kinematics Overview

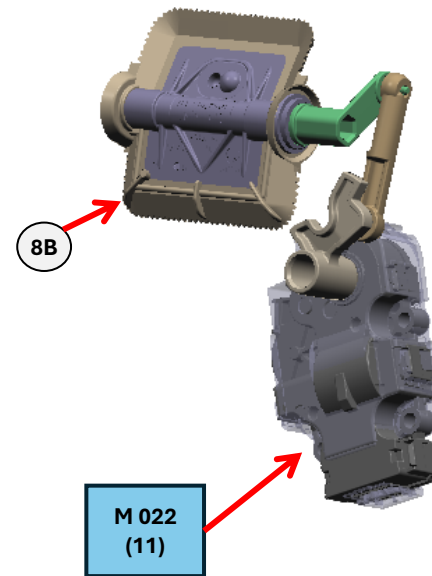
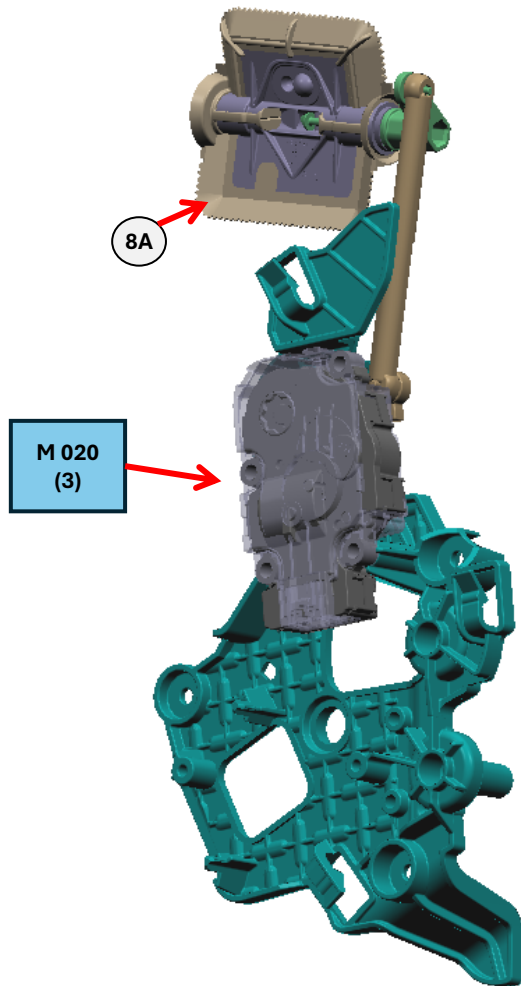

# G45 HVAC: Air Vent Flaps/Kinematic & Stepper Motor Master Info.

## FLAP #9: Rear Upper Vent Flap (Center Console)

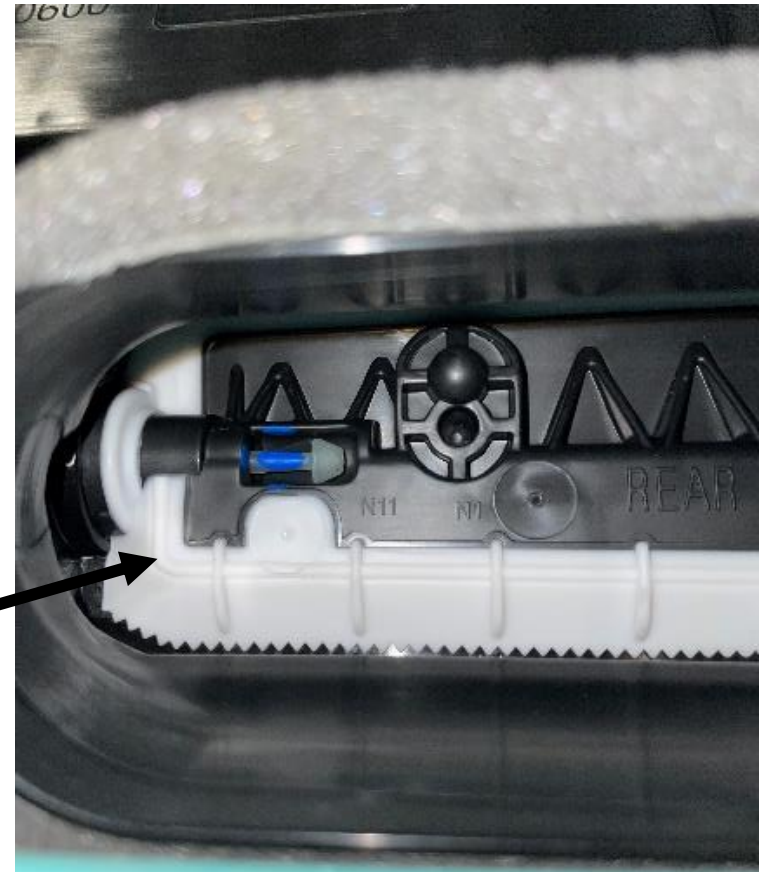
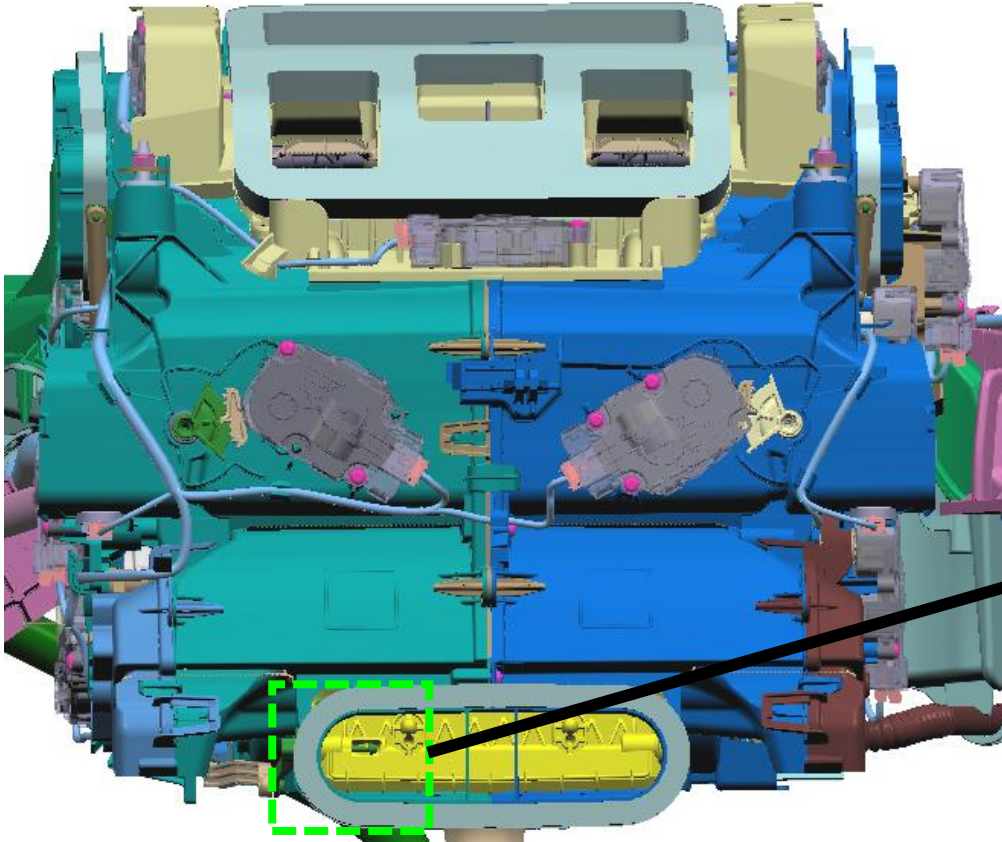

# G45 HVAC: Air Vent Flaps/Kinematic & Stepper Motor Master Info.

## FLAP #9 Kinematics Overview (Highlighted Yellow)

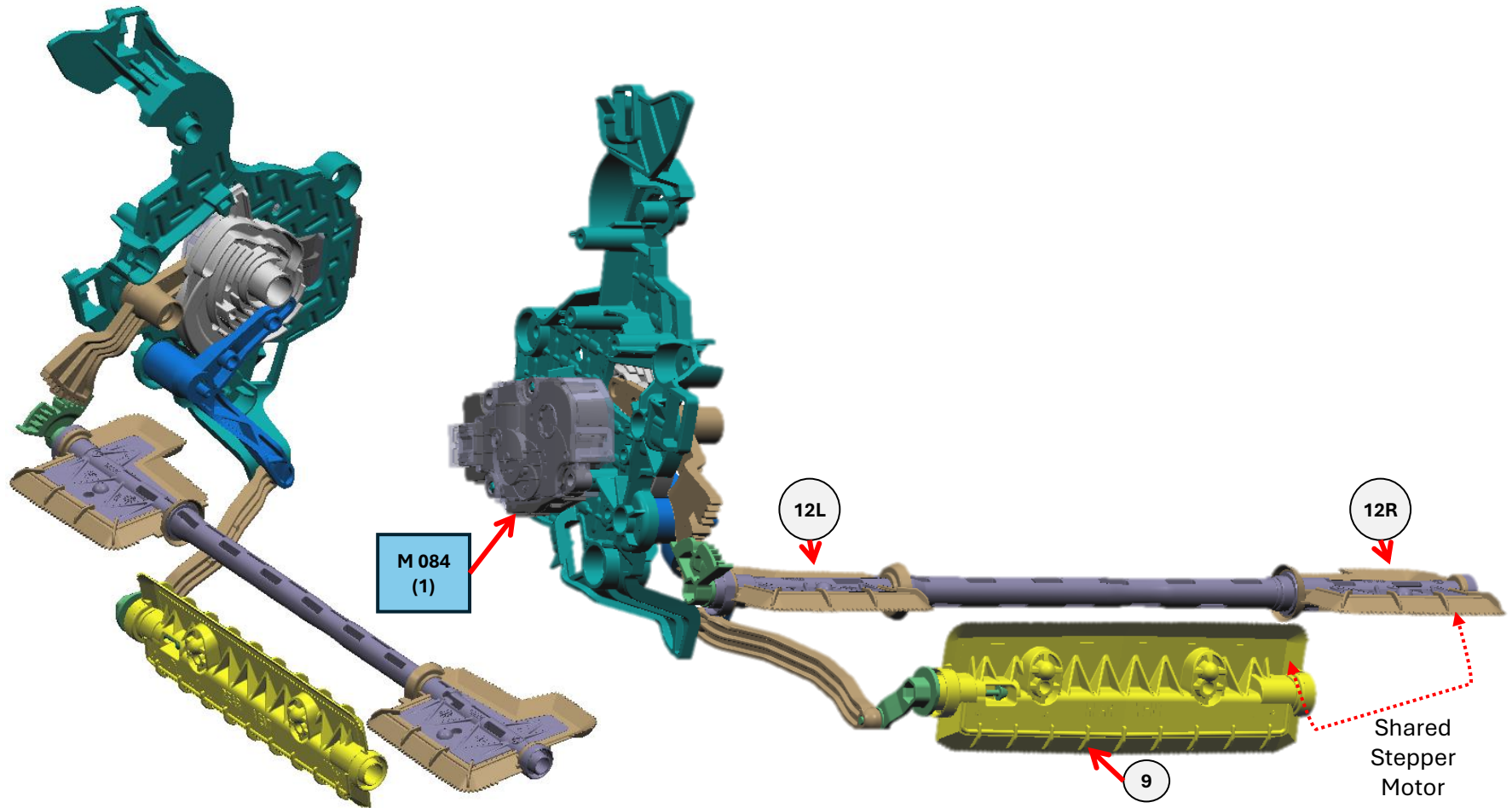

# G45 HVAC: Air Vent Flaps/Kinematic & Stepper Motor Master Info.

## FLAP #10: Rear Cold Temp. Mixing Flap

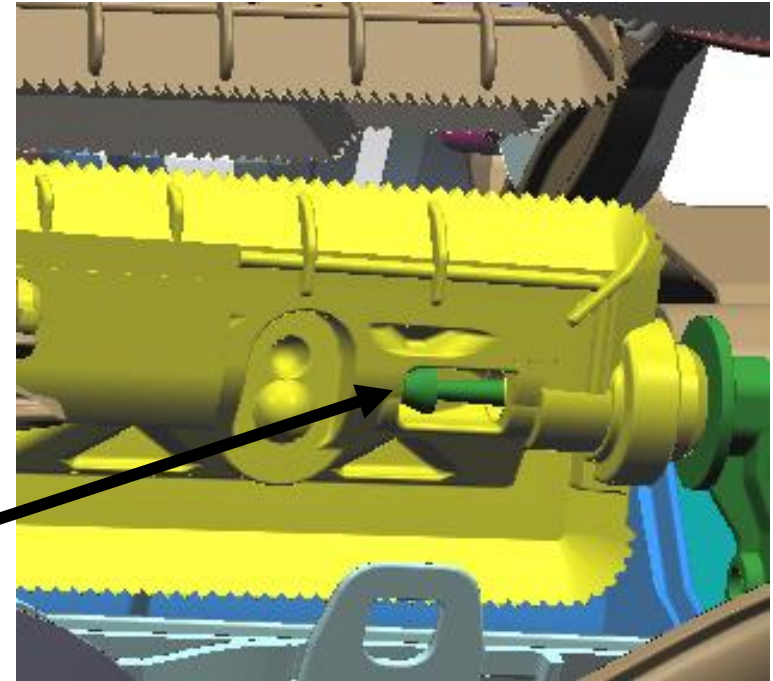
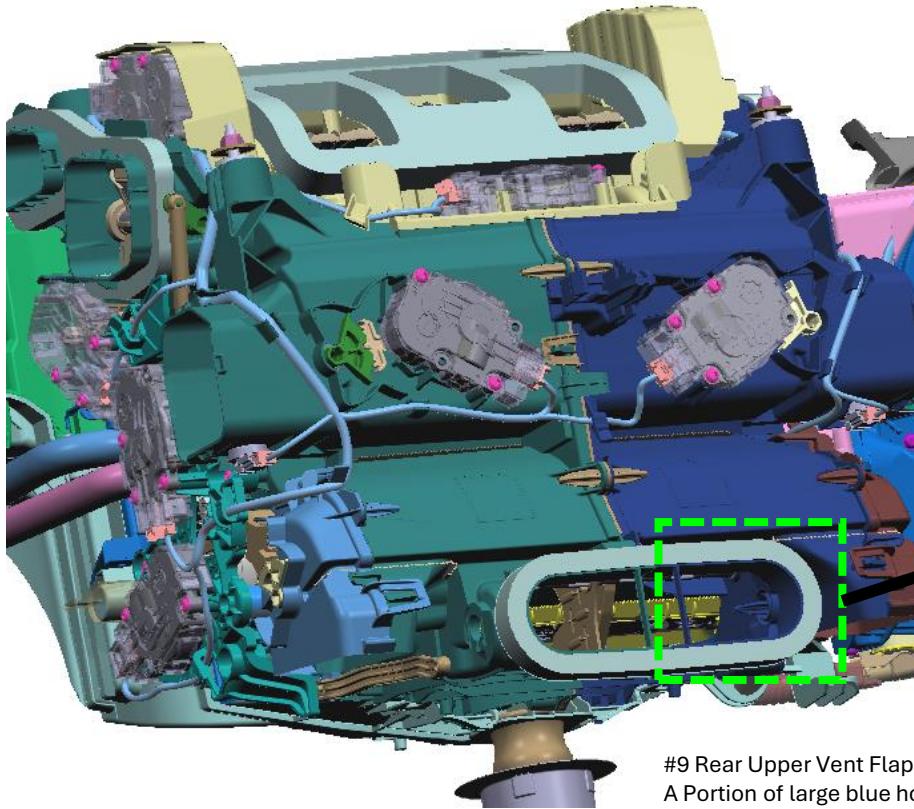

#9 Rear Upper Vent Flap (Center Console) removed from CAD image for easier visibility.

A Portion of large blue housing also removed for easier visibility.

A bad push-pin connection on Flap #10 can also affect Flap #11. Flap #11 is connected to Flap #10.

**ONE Push Pin (RIGHT side only)!**

# G45 HVAC: Air Vent Flaps/Kinematic & Stepper Motor Master Info.

## FLAP #10 Kinematics Overview (Highlighted Yellow)

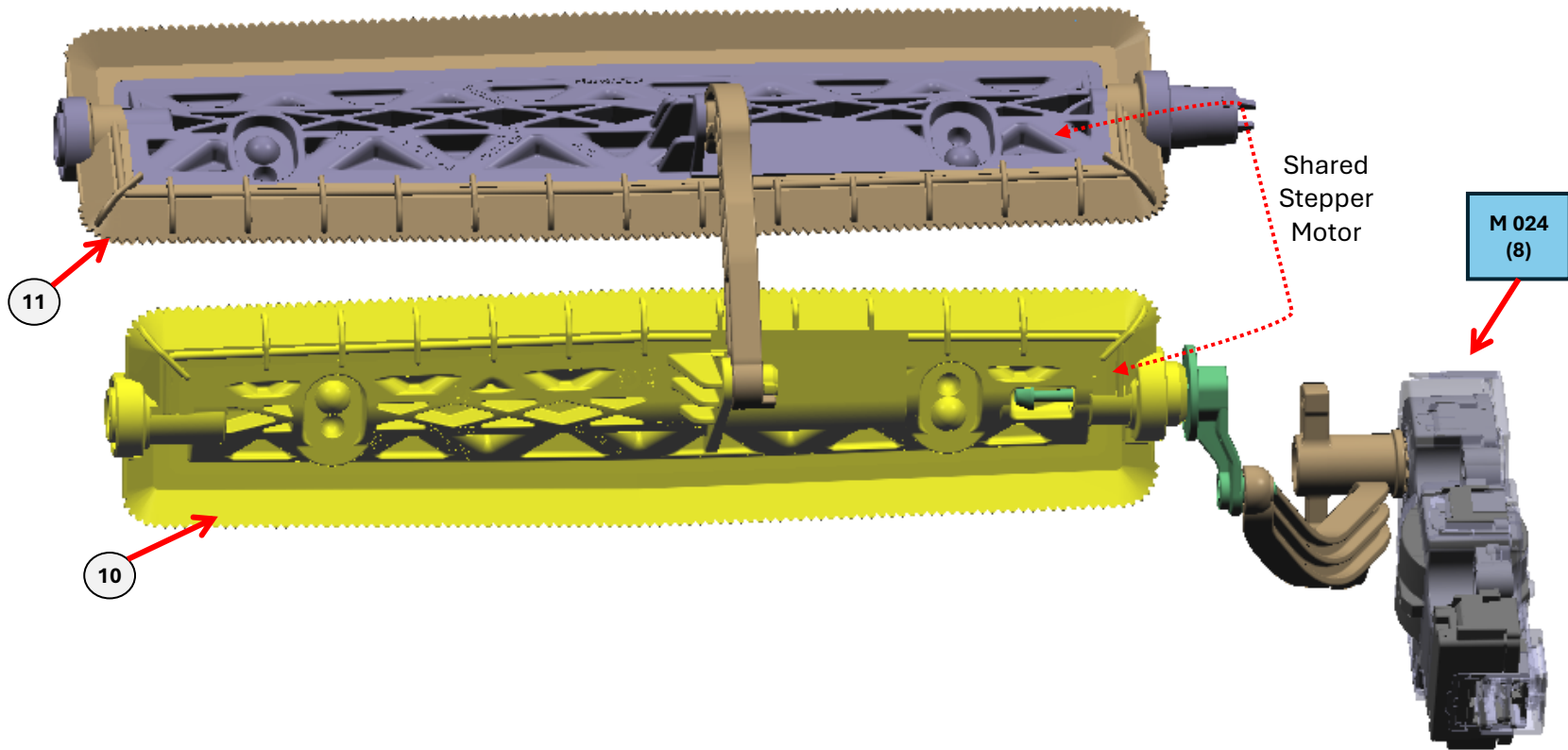

# G45 HVAC: Air Vent Flaps/Kinematic & Stepper Motor Master Info.

## FLAP #11: Rear Warm Temp. Mixing Flap

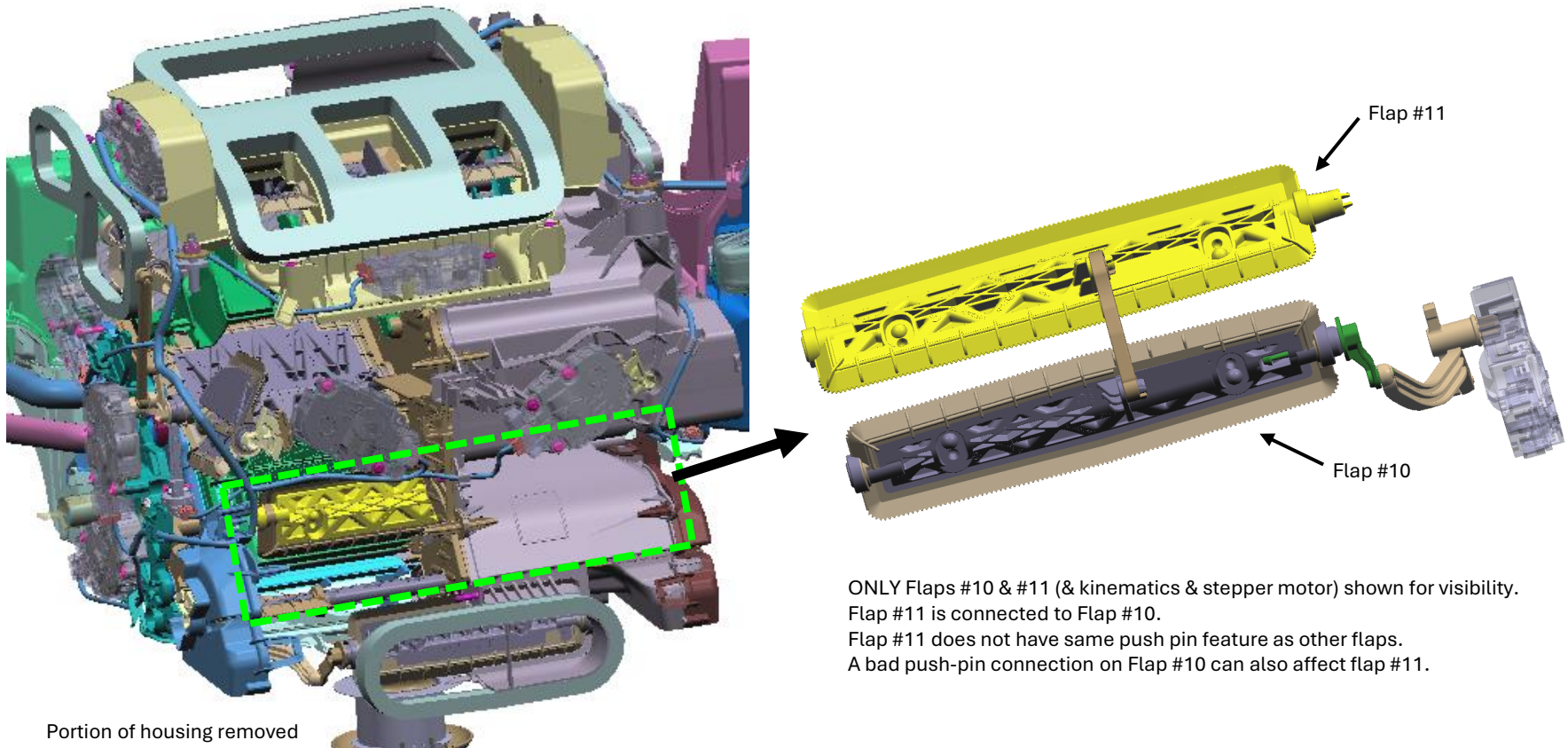

ONLY Flaps #10 & #11 (& kinematics & stepper motor) shown for visibility.  
Flap #11 is connected to Flap #10.  
Flap #11 does not have same push pin feature as other flaps.  
A bad push-pin connection on Flap #10 can also affect flap #11.

Portion of housing removed

**NO Push Pin on Flap #11 (Please see Flap #10)!**

# G45 HVAC: Air Vent Flaps/Kinematic & Stepper Motor Master Info.

## FLAP #11 Kinematics Overview (Highlighted Yellow)

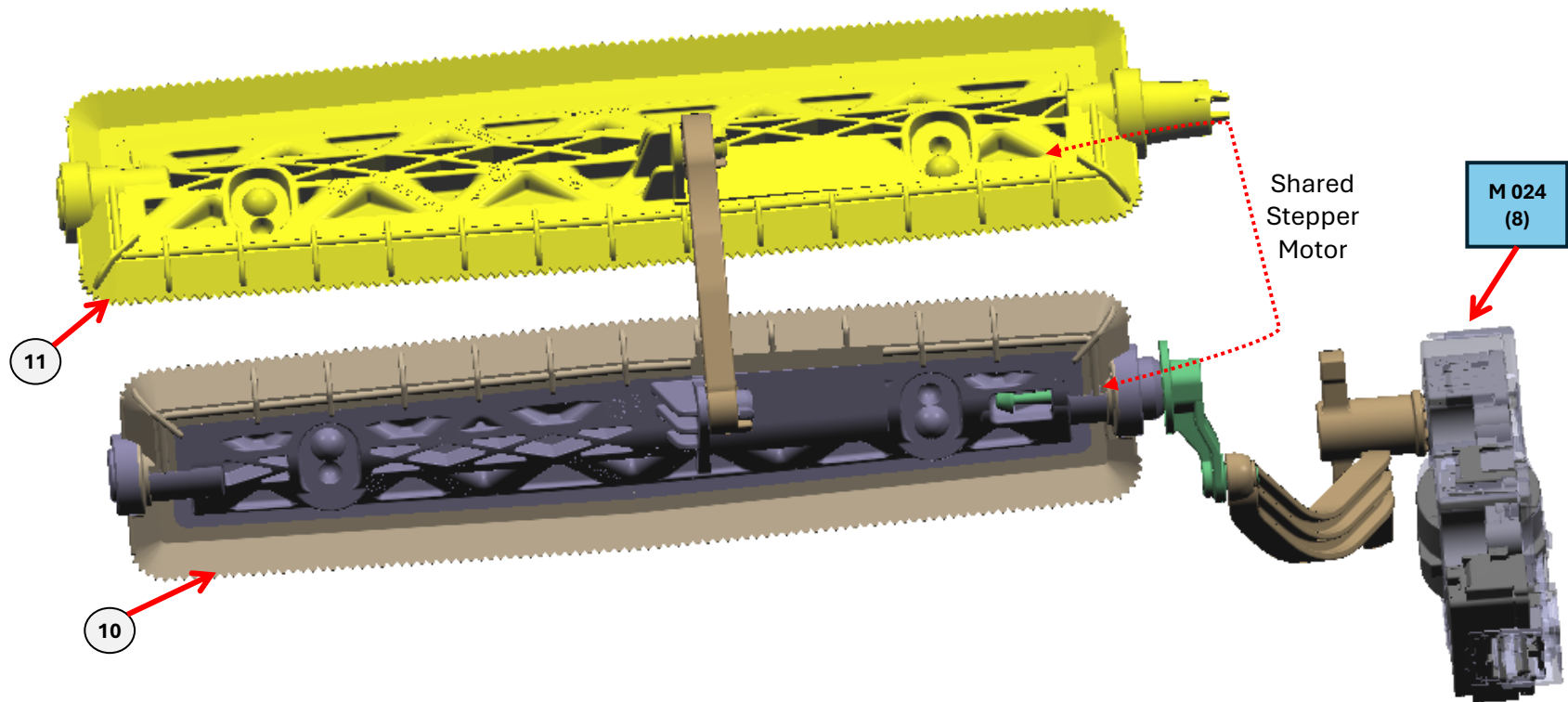

# G45 HVAC: Air Vent Flaps/Kinematic & Stepper Motor Master Info.

## FLAP #12: Rear Footwell Air Flaps L/R x2 (connected)

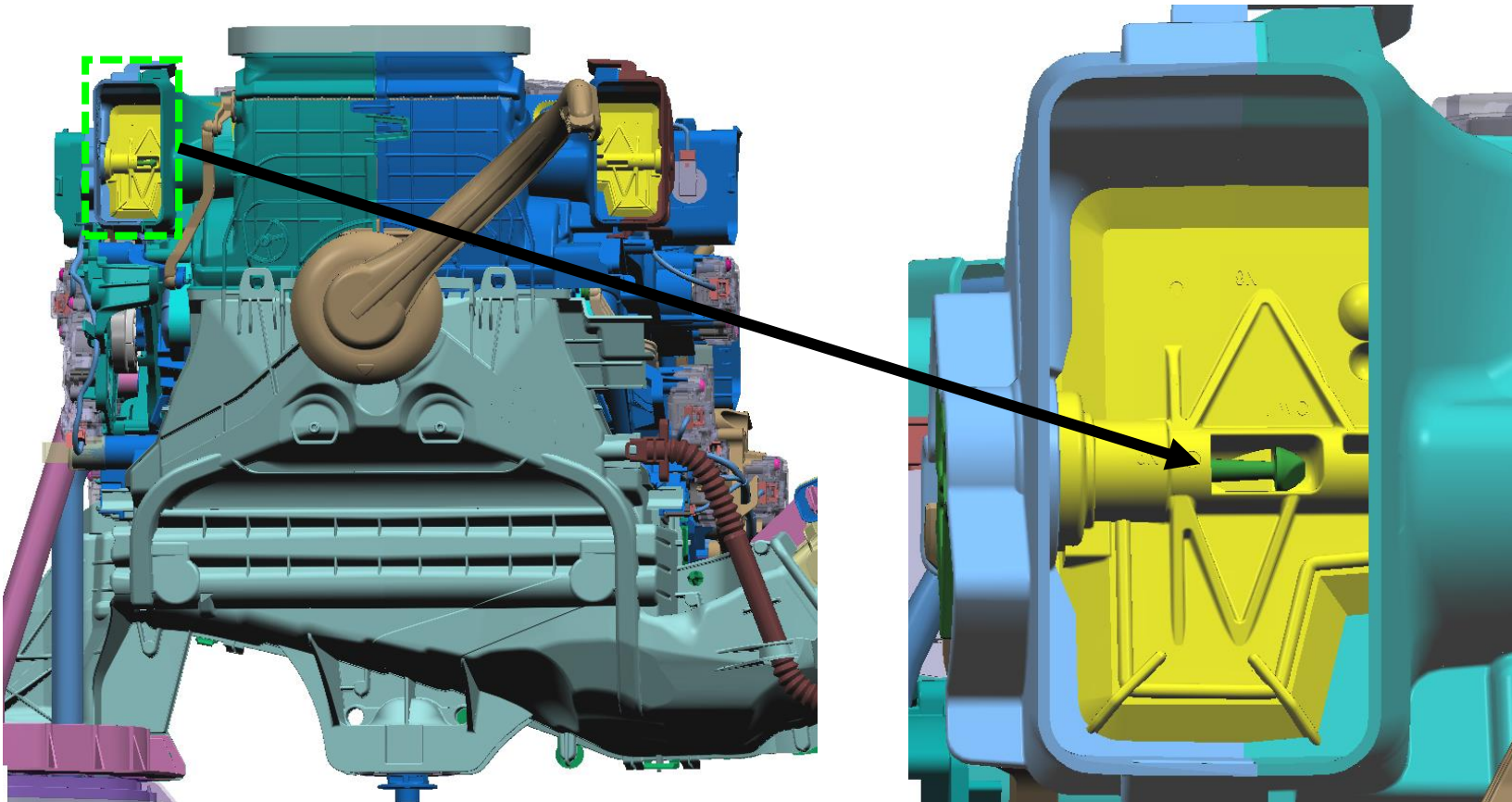

ONE Push Pin (RIGHT side only)!

# FLAP #12 Kinematics Overview (Highlighted Yellow)

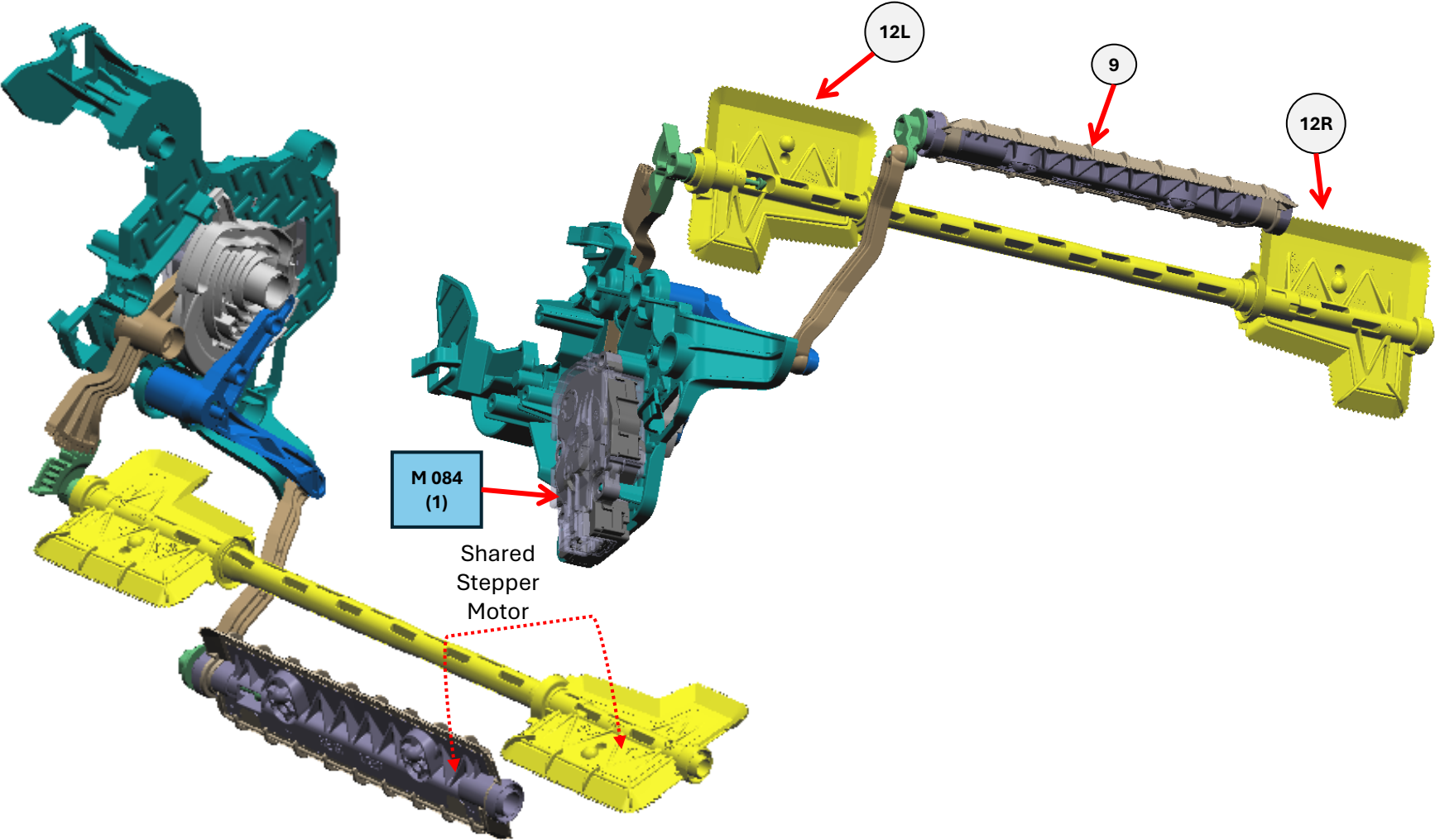

# G45 HVAC: Air Vent Flaps/Kinematic & Stepper Motor Master Info.

## FLAP #13: Indirect Air Flap & Complete Kinematics Overview

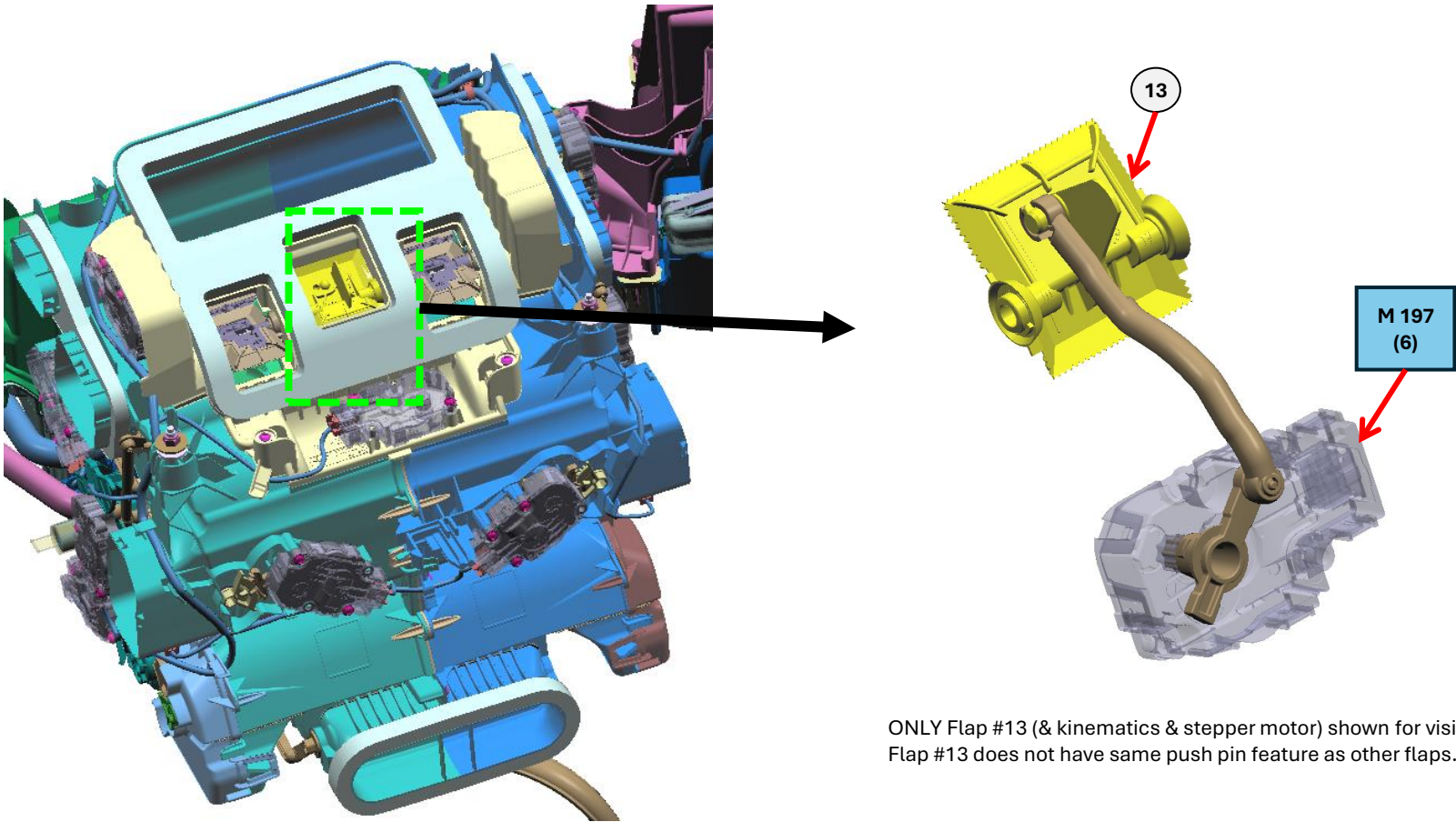

ONLY Flap #13 (& kinematics & stepper motor) shown for visibility.  
Flap #13 does not have same push pin feature as other flaps.

# G45 HVAC: Air Vent Flaps/Kinematic & Stepper Motor Master Info.

## Push Pin Issue

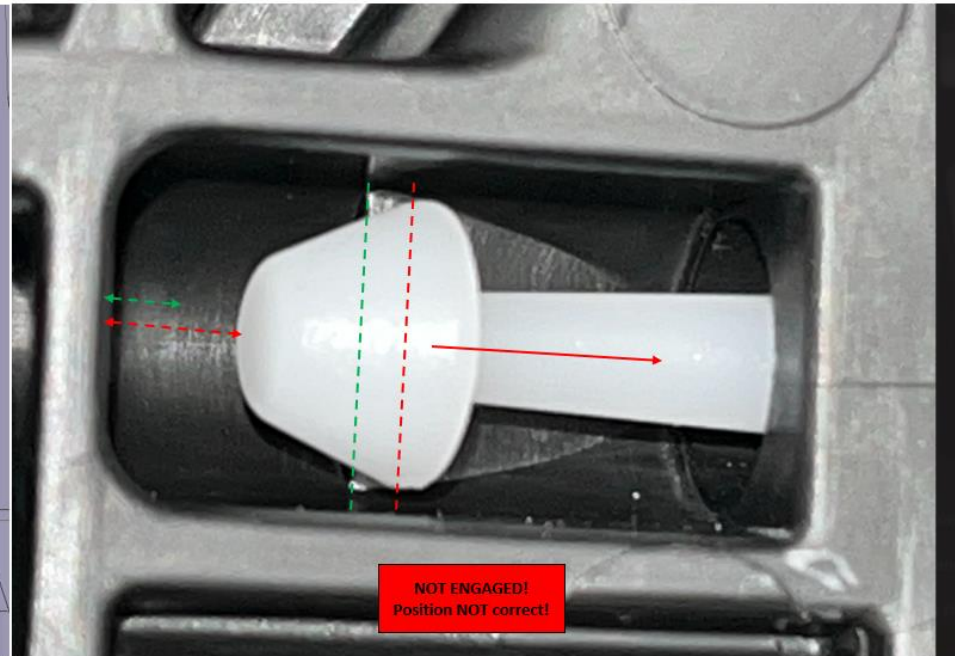
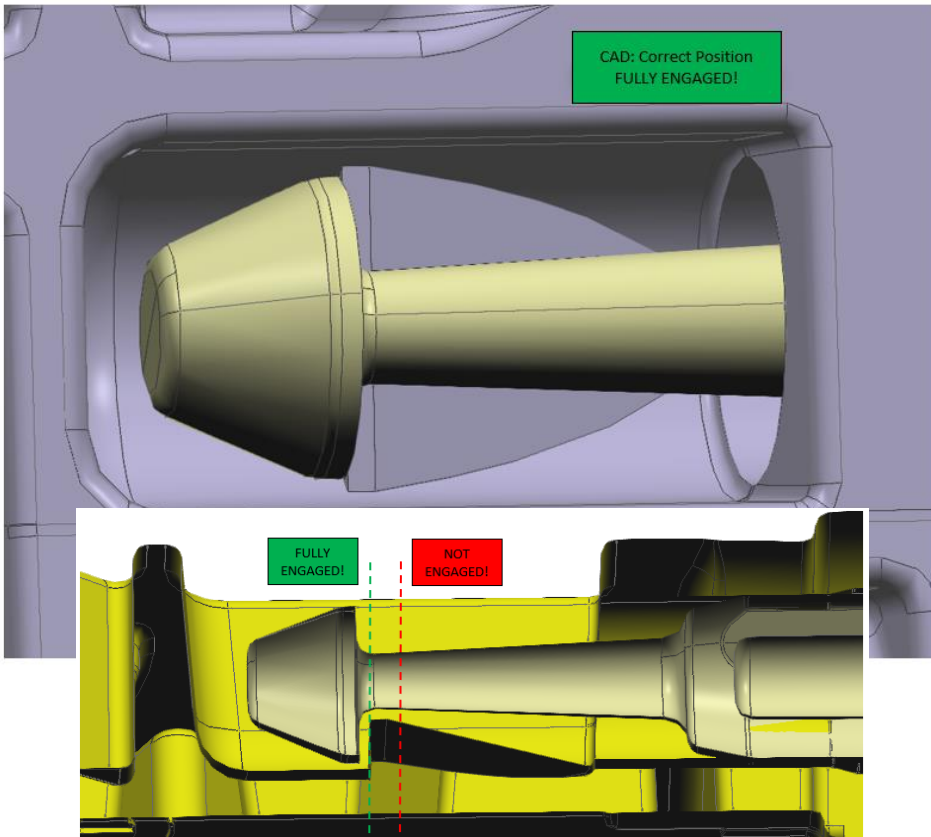

# G45 HVAC: Air Vent Flaps/Kinematic & Stepper Motor Master Info.

## Push Pin Issue

**OK part – Push pin mushroom head locked completely over the flap ramp**

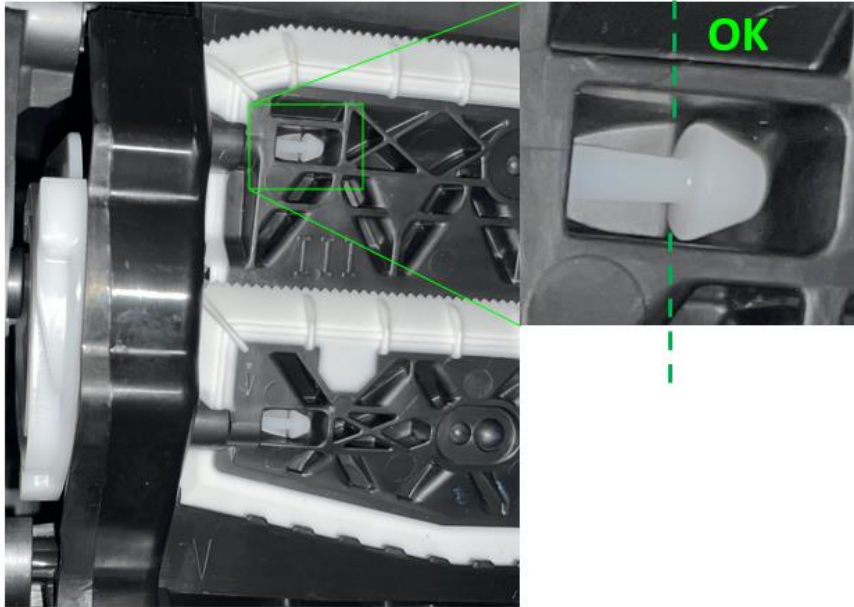

**NOK part – Push pin mushroom head NOT over the flap ramp (not snapped)**

