



## STAR ONLINE PUBLICATION



**Case Number:** S2523000045

**Release Date:** May 2025

**Symptom/Vehicle Issue:** C058E-00 - BRAKE BOOSTER MOTOR "B" POSITION SENSOR CIRCUIT RANGE/PERFORMANCE

**Discussion:** Service diagnostics have recently been updated for diagnostic trouble code (DTC) C058E-00. When following the DTC diagnostics if the results take you to the final step (step 11) and the answer is “yes”, the DTC did return”, it will be necessary to replace **both** the brake system control module (BSCM) and the electronic brake booster (EBBM). Both parts #1 BSCM and #8 EBBM are shown below.

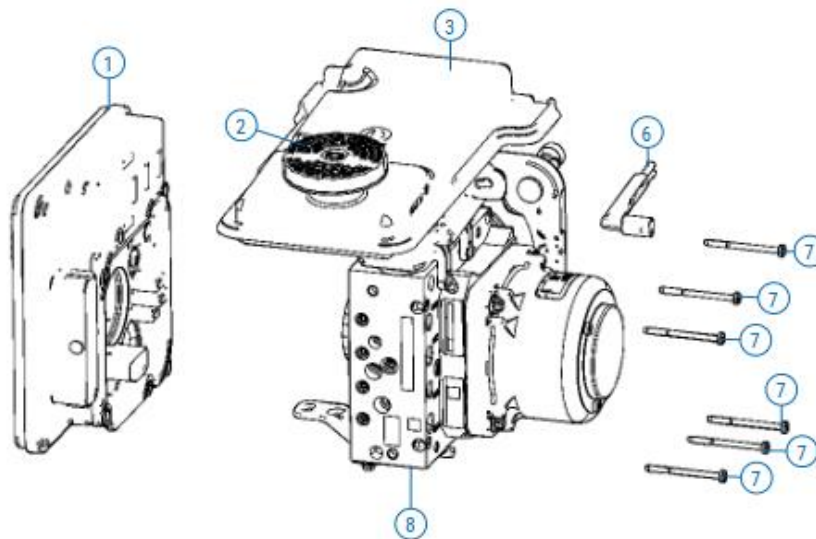

This document does not authorize warranty repairs. This communication documents a record of past experiences. STAR Online does not provide any conclusions about what is wrong with the vehicle. Rather, it captures all previous cases known that appear to be similar or related to the vehicle symptom / condition. You are the expert, and you are responsible for deciding on the appropriate course of action.

**Contact STAR Center, or your Technical Assistance Center Via TechConnect, eCONTACT or Service Library entry if no solution is found.**