



Technical Service Bulletin

SUBJECT:		NO.: TSB-23-33-002REV3	
STRUT BEARING NOISE - REVISED		DATE: April 2025	
		MODEL: 2022-24 Outlander	
CIRCULATE TO:	<input type="checkbox"/> GENERAL MANAGER	<input checked="" type="checkbox"/> PARTS MANAGER	<input checked="" type="checkbox"/> TECHNICIAN
<input checked="" type="checkbox"/> SERVICE ADVISOR	<input checked="" type="checkbox"/> SERVICE MANAGER	<input checked="" type="checkbox"/> WARRANTY PROCESSOR	<input type="checkbox"/> SALES MANAGER

This bulletin supersedes TSB-23-33-002REV2 issued November 2024 to update the Affected Vehicles, Procedure, Parts and Warranty Information sections. Revisions are italicized and indicated by ◀

PURPOSE

This TSB provides direction when front strut noise is heard while turning the steering wheel. The creaking or popping sound may be caused by the strut bearing support which can become deformed by the loaded spring and cause noise during use of the steering wheel.

On a customer complaint basis and **only** for the strut which has noise, replace both the strut bearing and spring with countermeasure parts.

AFFECTED VEHICLES

2022-2024 Outlander (VIN cut-off JA4J3WA83RZ090153 / 10/21/2024) ◀

AFFECTED SERVICE MANUAL

- 2022-2024 Outlander Service Manual, Volume 3, Group 33 - Front Suspension

PROCEDURE

Please refer to this bulletin and the affected Service Manual, Volume 3, Group 33 - Front Suspension, Removal and Installation, Front Coil Spring and Strut as necessary. ◀

Note: Impact tools are not recommended for use on the spring compressor. Instead, use hand tools.

Test drive vehicle upon completion of procedure.



Copyright 2025, Mitsubishi Motors North America, Inc.

The information contained in this bulletin is subject to change. For the latest version of this document, go to the Mitsubishi Dealer Link, MEDIC, or the Mitsubishi Service Information website (www.mitsubishitechinfo.com).

1. **Only on the strut which has the noise** and on a customer complaint basis:

- Replace the **BEARING, STRUT SUPPORT and SPRING, FRONT** with a new countermeasure part.
- Replace the **PAD, SPRING UPPER and INSULATOR ASSY, STRUT.**
 - **Please note:** If you hear the noise from the left side, only the left side needs to be replaced.

CHECKING FOR ABNORMAL NOISE

Perform steering maneuvers such as full lock turns while stationary, or right and left turns, and check/listen for any noise coming from the front strut bearings.

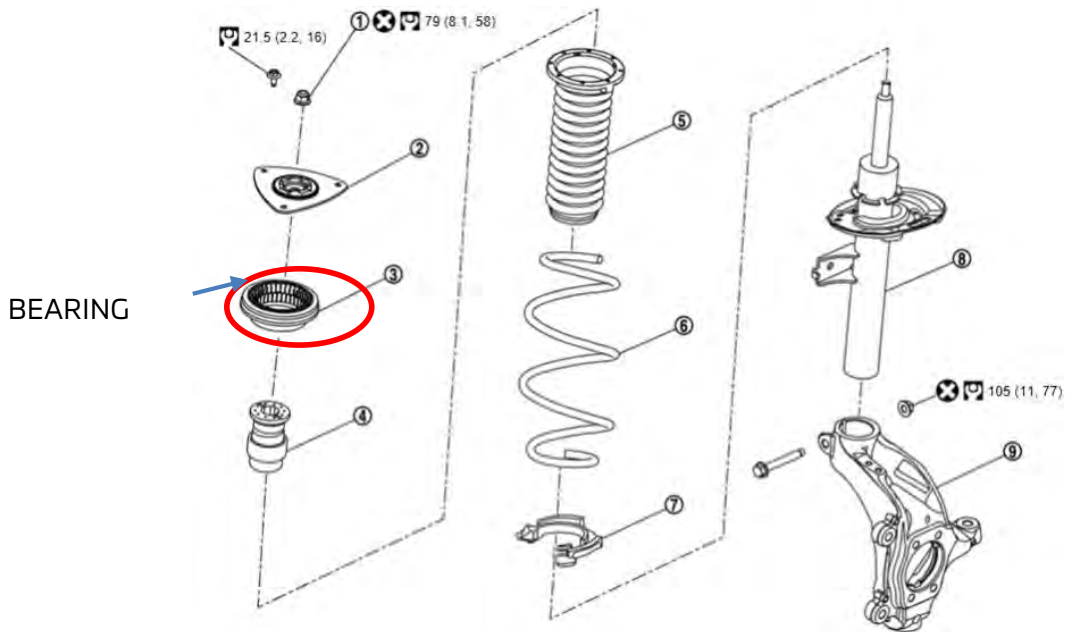

Following the Service Manual, remove the parts and, after reviewing the assembly precautions that begin on page 4 of this bulletin, assemble the countermeasure SPRING, BEARING, PAD SPRING UPPER, INSULATOR ASSY and Nuts.

IDENTIFYING THE FRONT SUSPENSION COIL SPRINGS

Install the front coil spring so that the paint markings are located at 1.25 turns from the bottom end.

	New	Old
Part Number	54010W480P (4WD) 54010W490P (2WD)	54010W300P (4WD) 54010W310P (2WD)
Marking location [A]	 <p>Example: Spring, Front/54010W480P/Orange-White</p>	
Identification	54010W480P: Orange-White 54010W490P: Green-White	54010W300P: Orange-Purple 54010W310P: Green-Purple

ASSEMBLY PRECAUTIONS

1. When replacing parts, ensure that the work is carried out by two or more people. Additionally, prepare two sets of dual-axis spring compressors as described in the Workshop manual, and perform the work using three axes.

Using a three-axis spring compressor ensures the coil spring aligns properly with the strut, preventing misalignment and uneven load on the bearing

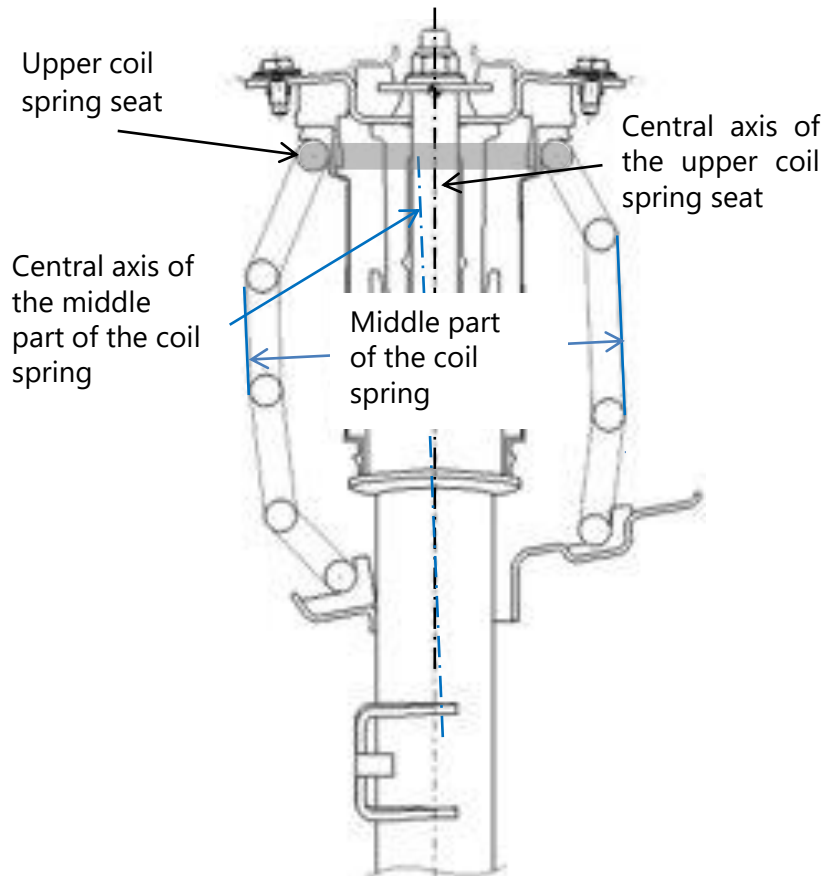

COMPONENT ASSEMBLY PROCEDURE

1. Marking the Coil Spring

View the component from the direction of VIEW D and mark positions a and b (○). View the component from the direction of VIEW E and mark position c (△).

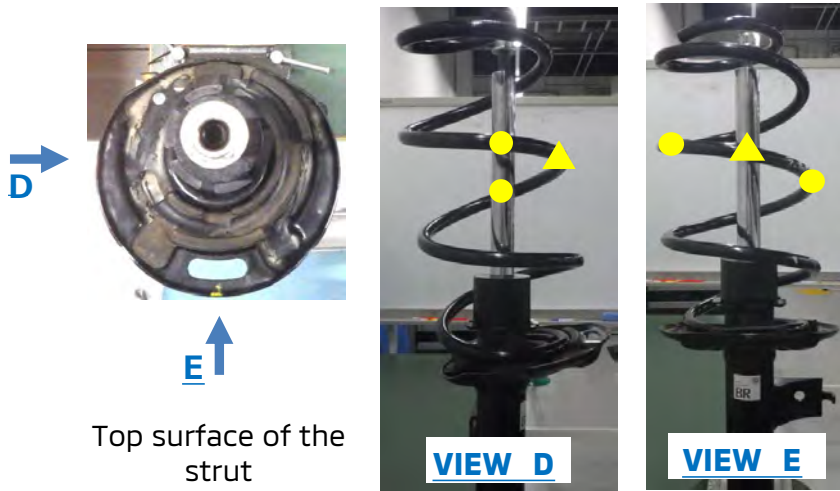

Marking Positions:

【○】

- a: Position aligned with the central axis of the strut
- b: Position 180° opposite, aligned with the central axis of the strut

【△】

- c: Position aligned with the central axis of the strut from direction E

NOTE: Marking should align with the central axis of the strut

2. Installing the Coil Spring Compressor

Install the spring compressor so that it passes over the marked position "a", ensuring the compressor hook is perpendicular to the spring. (Do the same for position "b".) Then, compress evenly on both sides until the top of the strut rod extends approximately 15mm (see enlarged photo below).

3. Installing the Third-Axis Spring Compressor:

Install the third-axis spring compressor so that it passes over the marked position.

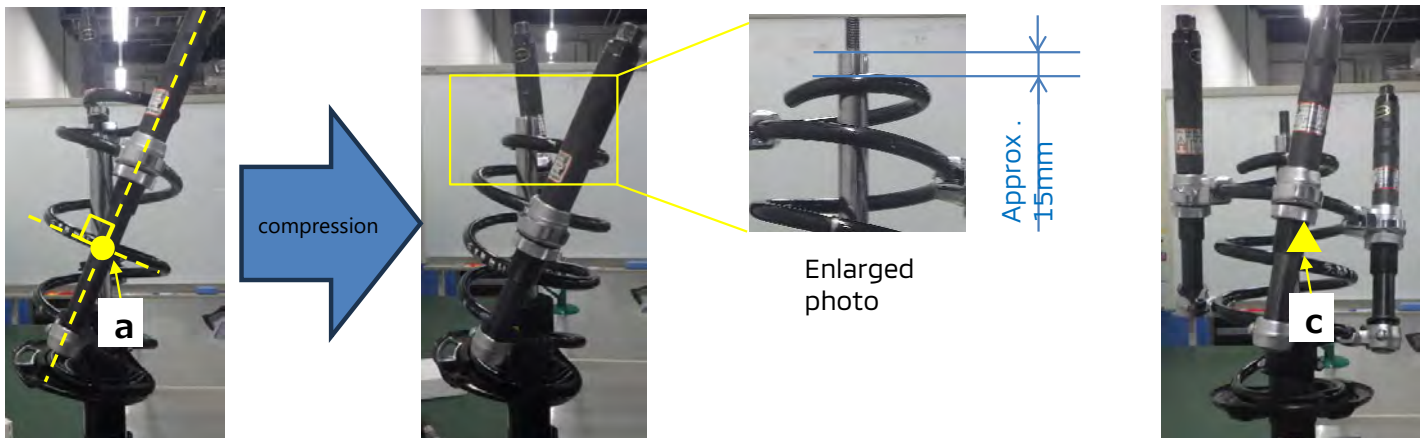

NOTE:

- Be aware with the installation position of the compressor, as the first 0.75 turns from the upper end of the coil spring will contact the upper pad.
- Ensure the compressor at the marked position is installed perpendicular to the spring.

4. Central Axis Alignment

Due to the misalignment between the central axis of the upper coil spring seat and the central axis of the middle part of the spring, compressing with two axes causes the upper coil spring seat's central axis to deviate from the strut's central axis, moving closer as indicated by the orange arrow. To correct this, compress the third axis (★) until the central axis of the upper coil spring seat aligns with the strut's central axis. Then, gradually compress all three axes evenly while maintaining the alignment of both central axes.

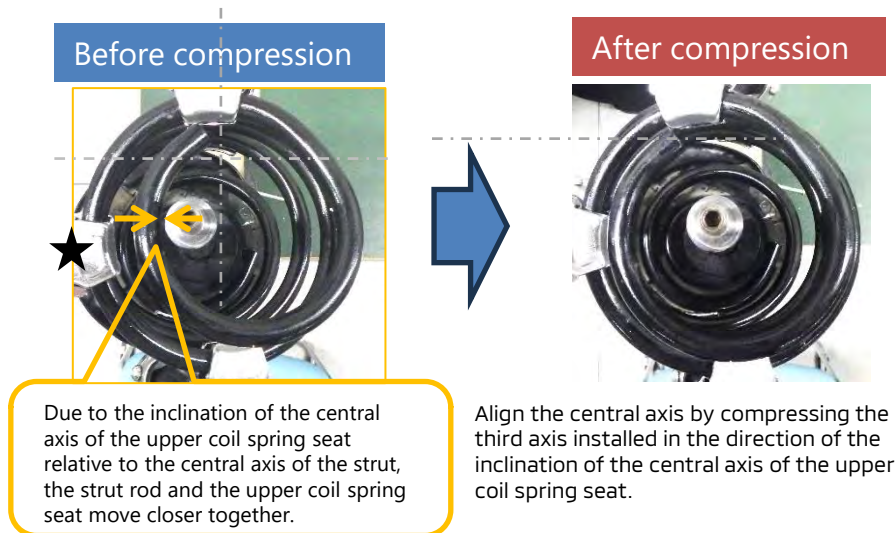

5. Releasing the Spring Compressor

- Carefully release the three axes evenly and gradually to ensure the central axis of the upper coil spring seat does not deviate from the central axis of the strut.
- Install the strut insulator, strut bearing, and upper pad. While lightly pressing the top of the strut insulator by hand, release until the upper pad contacts the upper coil spring seat. If there is no contact, remove the upper pad and other components, and repeat steps a and b.



6. Tightening the Strut Upper End Nut and checking the position of the Lower Pad at the Strut Lower End

After the strut upper end nut is tightened in position of step 5 (Releasing the Spring Compressor), the position of the lower pad at the strut lower end strut and the coil spring will be fixed. In this case, if the lower coil spring seat interferes strongly with the lower pad in the red line area as below, it may cause misalignment of the coil spring axis.

Therefore, before tightening the strut upper end nut, please move and set the coil spring to make sure the lower coil spring seat should not interfere strongly with lower pad in the red line area.

After that, tighten the nut at the upper end of the strut, ensuring the central axis of the strut bearing and upper pad do not deviate from the central axis of the strut.

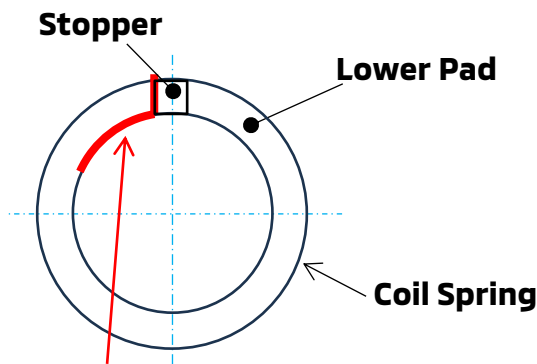
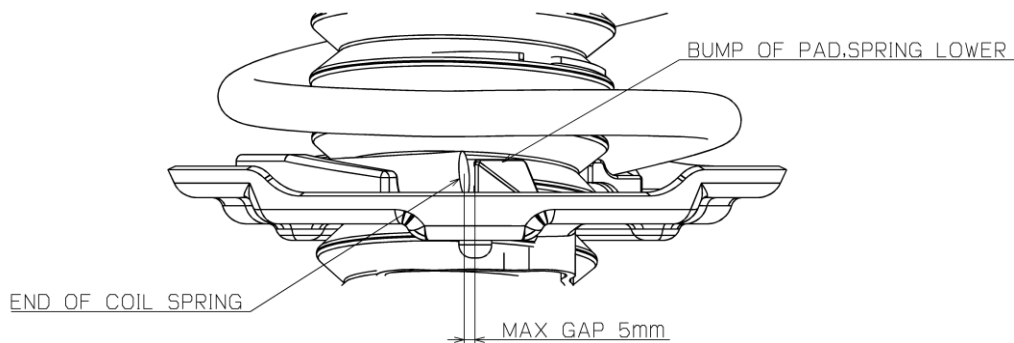

The lower spring should not interfere strongly with lower pad in the red line area.

NOTE:

Ensure that the coil spring does not strongly interfere with the upper pad in the axial direction and that there is no gap between the coil spring and the upper pad in the axial direction.

7. Checking the Installation Positioning

As shown in Photo G, ensure that a 0.1mm thickness gauge does not fit in the gap between the strut bearing and the upper pad at the position 0.5 turns from the upper end of the coil spring (red line area in the lower part of the upper pad diagram 1).

If the 0.1mm thickness gauge fits, the load distribution of the coil spring is uneven, which can damage the strut bearing (causing abnormal noise). In such a case, return to step 2 and redo the process.

Additionally, inspect the lower part of the upper pad and ensure that the coil spring does not significantly interfere with the upper pad in the axial direction (red line area in the lower part of the upper pad diagram 2).

If they significantly interfere, repeat step 2 (Installing the Coil Spring Compressor) again.

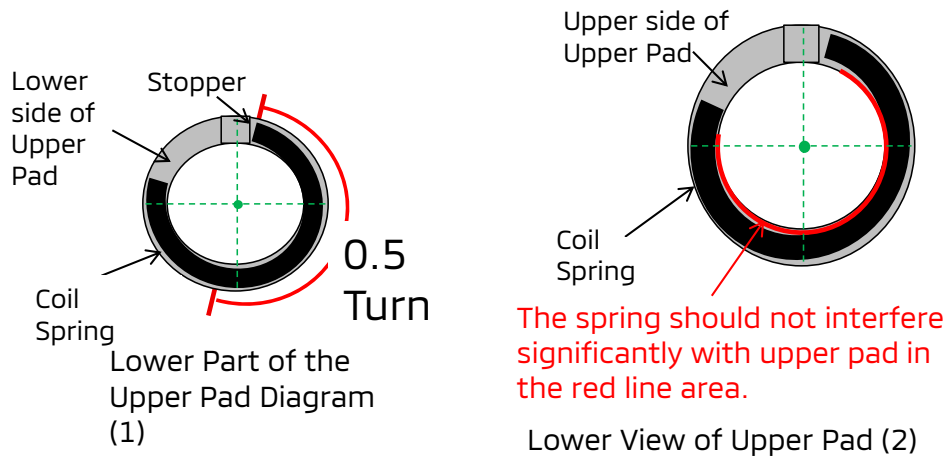

Photo G



REMOVAL AND INSTALLATION
FRONT COIL SPRING AND STRUT

Exploded View

SEC. 401

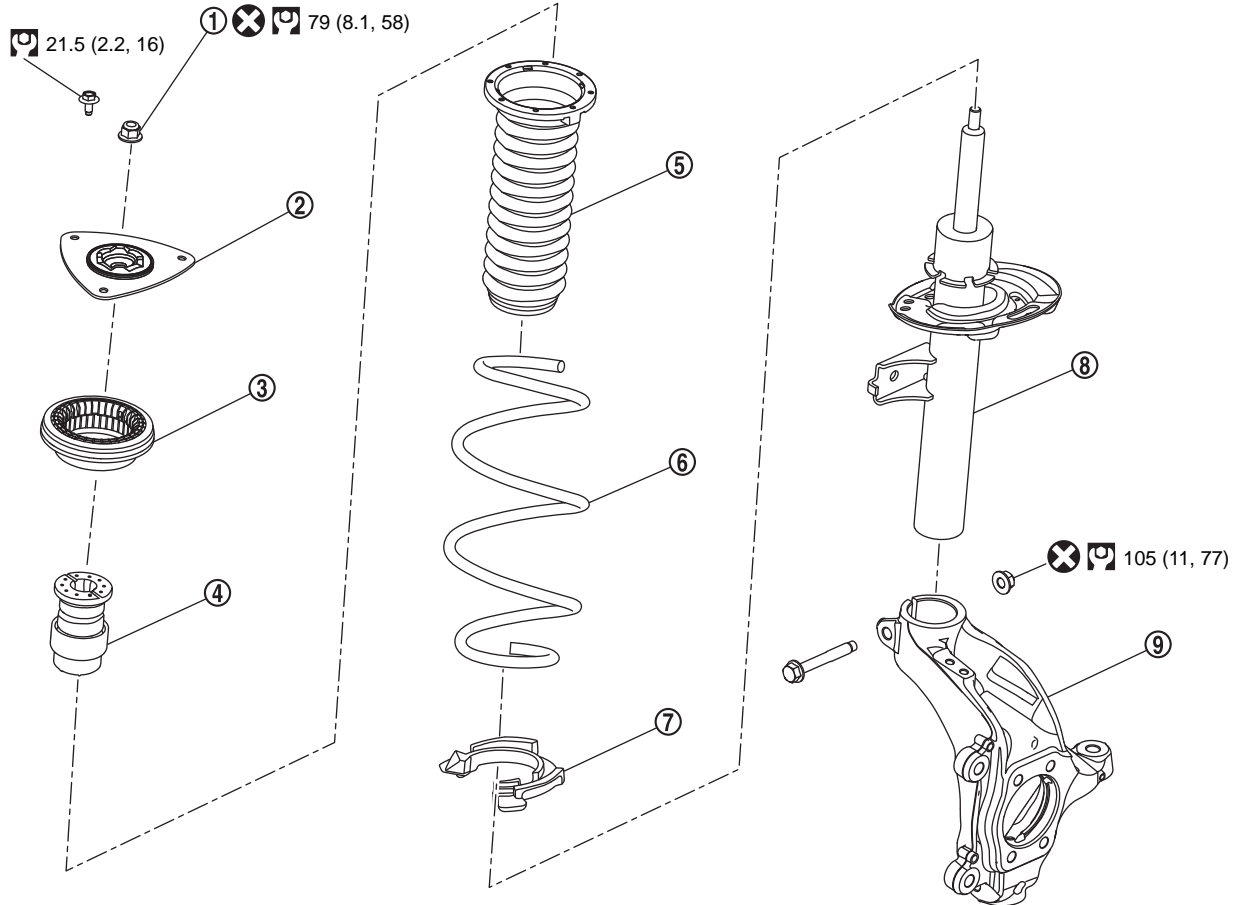

CF100AGVAA00USA

①	Piston rod lock nut	②	Mounting insulator	③	Mounting bearing
④	Bound bumper	⑤	Upper rubber seat	⑥	Coil spring
⑦	Lower rubber seat	⑧	Strut	⑨	Steering knuckle
	: N·m (kg·m, ft·lb)				
	: Always replace after every disassembly.				

Removal and Installation

REMOVAL

1. Remove cowl top cover. Refer to [COWL TOP](#).
2. Remove tires. Refer to Removal and Installation [ROAD WHEEL TIRE ASSEMBLY](#).
3. Remove wheel hub lock nut.
 - For 2WD: Refer to [FRONT WHEEL HUB AND KNUCKLE](#).
 - For AWD: Refer to [FRONT WHEEL HUB AND KNUCKLE](#).
4. Remove brake hose lock plate. Refer to [FRONT](#).
5. Remove front wheel sensor. Refer to [FRONT WHEEL SENSOR](#).
6. Remove brake hose bracket. Refer to [FRONT](#).

7.Remove brake caliper assembly. Hang brake caliper assembly in a place where it will not interfere with work. Refer to [BRAKE CALIPER ASSEMBLY](#)

CAUTION:

Never depress brake pedal while brake caliper is removed.

8.Remove disc rotor.

- For 2WD: Refer to [FRONT WHEEL HUB AND KNUCKLE](#).
- For AWD: Refer to [FRONT WHEEL HUB AND KNUCKLE](#).

9.Remove steering outer socket.

- For 2WD: Refer to [FRONT WHEEL HUB AND KNUCKLE](#).
- For AWD: Refer to [FRONT WHEEL HUB AND KNUCKLE](#).

10.Remove trans verse link mounting bolt and nut. Refer to [TRANSVERSE LINK](#).

11.Separate stabilizer connecting rod from strut assembly. Refer to [FRONT STABILIZER](#).

12.Remove the steering knuckle and strut assembly.

13.Separate the connection of strut assembly and steering knuckle as follows.

CAUTION:

Be sure to keep the following procedure because steering knuckle may be damaged when you enlarge the gap of steering knuckle too much.

- (1) Remove strut mounting bolts from steering knuckle.
- (2) Measure the gap (A) of the steering knuckle. And then mark the enlarged limit (B) to the chisel.

NOTE: Use the appropriate hammer if necessary during removal of the steering knuckle.

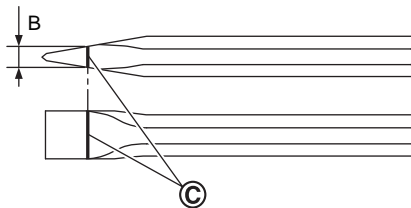
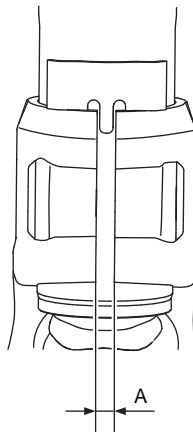

CF100AF0AA00USA

Ⓒ	Marking
---	---------

Enlarged limit (B) = gap (A) + 2.5 mm (0.098 in)

NOTE:

Standard of gap: 6.9 ± 0.5 mm (2.56 ± 0.02 in)

- (3) Enlarge the gap of the steering knuckle with the chisel (A) (commercial service tool) not to surpass a limit as shown in the figure.

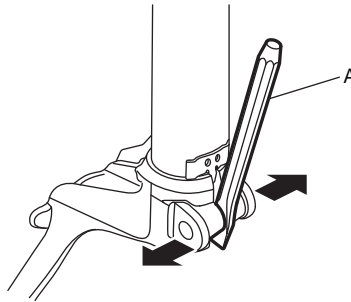

CF100AF1AA00USA

CAUTION:

- Never enlarge the gap more than 2.5mm (0.098in).
- Be careful not to damage the projection (A) and strut assembly (B) with the chisel.

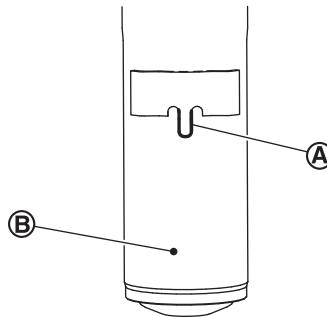

CF100AF2AA00USA

- (4) Separate the connection of strut assembly and steering knuckle.

CAUTION:

- Never place drive shaft joint at an extreme angle.
- Be careful not to overextend slide joint.
- Never allow drive shaft to hang down without support for joint sub-assembly, shaft and the other parts.
- Be sure to remove lubricants if lubricant has been used to separate the connection of strut assembly and steering knuckle.

14. Remove mounting bolt of mounting insulator, and then remove strut assembly.

INSTALLATION

Note the following, and install in the reverse order of removal.

Strut Assembly

- When installing strut assembly to the vehicle, set the mounting insulator to the direction shown in the figure.

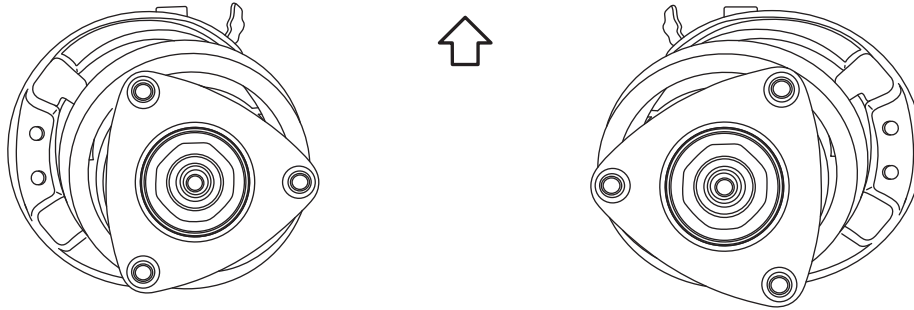

CF100AGWAA00USA

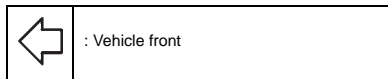

CAUTION:

Never reuse strut mounting nut.

- Perform final tightening of fixing parts at the vehicle installation position (rubber bushing), under unladen conditions with tires on level ground.
- Perform inspection after installation. Refer to Inspection [FRONT COIL SPRING AND STRUT](#).
- After replacing the strut, always follow the disposal procedure to discard the strut. Refer to [FRONT COIL SPRING AND STRUT](#).

Strut Assembly and Steering Knuckle Connection

CAUTION:

Be sure to remove lubricants if lubricant has been used to separate the connection of strut assembly and steering knuckle.

Install the steering knuckle to strut assembly as follows.

- Set suitable jack under steering knuckle.
- Align the gap (A) of steering knuckle to the projection part (B) of strut.

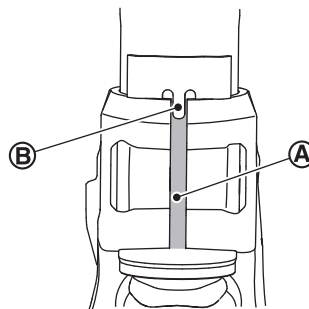

CF100AF9AA00USA

- Tighten the mounting bolt with pushing up the steering knuckle ① until contacts stopper bracket (A) end face, using a suitable jack.

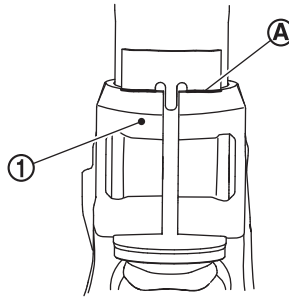

CF100FAAA00USA

CAUTION:

Check the stable condition when using a jack.

Disassembly and Assembly

DISASSEMBLY

CAUTION:

Never damage strut assembly piston rod when removing components from strut assembly.

1. Install strut attachment (A) (SST: ST35652000) to strut assembly and secure it in a vise.

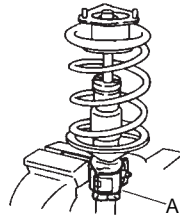

CF100AGXAA00USA

CAUTION:

When installing the strut attachment to strut assembly, wrap a shop cloth around strut to protect from damage.

2. Using a spring compressor (A) (commercial service tool), compress coil spring between spring upper seat and lower seat (strut assembly) until coil spring with a spring compressor is free.

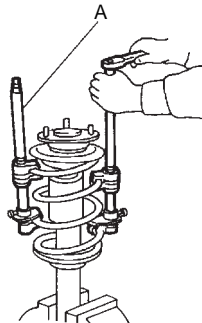

CF100AGYAA00USA

CAUTION:

Be sure a spring compressor is securely attached to coil spring. Compress coil spring.

3. Check coil spring with a spring compressor between spring upper seat and lower seat (strut assembly) is free. And then remove piston rod lock nut while securing the piston rod tip so that piston rod does not turn.

4. Remove mounting insulator, mounting bearing, upper rubber seat and bound bumper from strut.

5. After removing coil spring with a spring compressor (commercial service tool), then gradually release a spring compressor.

CAUTION:

Loosen while making sure coil spring attachment position does not move.

6. Remove lower rubber seat.

7. Remove strut attachment (A) (SST: ST35652000) from strut.

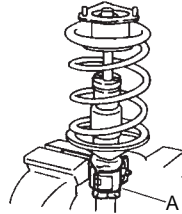

CF100AGXAA00USA

8. Perform inspection after disassembly. Refer to Inspection [FRONT COIL SPRING AND STRUT](#).

ASSEMBLY**CAUTION:**

Never damage strut assembly piston rod when installing components from strut assembly.

1. Install strut attachment (SST: ST35652000) to strut and secure it in a vise.

CAUTION:

When installing the strut attachment to strut assembly, wrap a shop cloth around strut to protect from damage.

2. Install lower rubber seat with its protrusion (A) on the lower area aligned with the hole (B) on the strut.

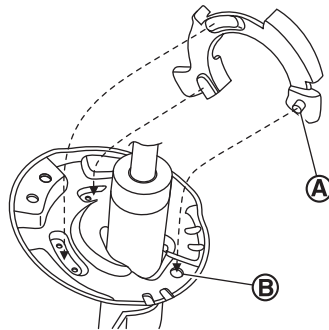

CF100AGZAA00USA

3. Compress coil spring using a spring compressor (commercial service tool), and install it onto strut assembly.

CAUTION:

- Be sure a spring compressor is securely attached to coil spring, before compress coil spring.
- Align the lower end of coil spring ① with lower rubber seat ② as shown in the figure.

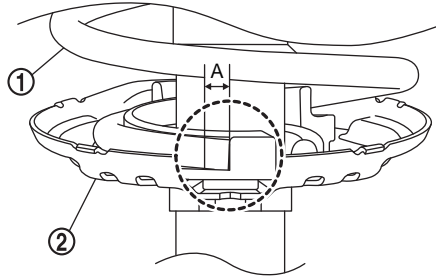

Dimension (A) : 5 mm (0.20)

- Set coil spring so that its paint marks are aligned with the position from the bottom end of the coil spring as shown in the figure.

CAUTION: On the new front coil spring for Outlander, there are two side by side paint markings. Please install the front coil spring so that the paint markings are located at 1.25 turns from the bottom end.



OLD paint marks

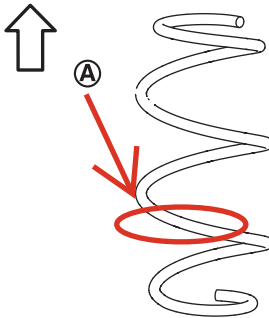

DF100AH1AA00USA



NEW paint marks



Japan production MODELS

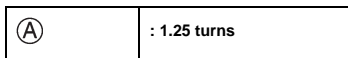

4. Apply soapy water to bound bumper.

CAUTION:

Never use machine oil.

5. Set bound bumper to piston rod of strut.

6. Install mounting bearing, mounting insulator and upper rubber seat on to spring.

CAUTION:

Never apply oils, such as grease, when installing the mounting bearing and mounting insulator.

7. Set the mounting insulator to the direction shown in the figure, and then install the mounting insulator, the upper rubber seat and the mounting bearing to the strut.

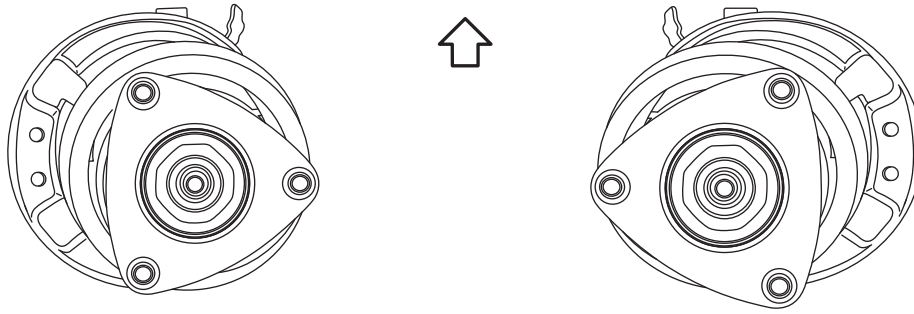

CF100AGWAA00USA

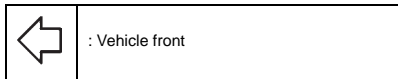

CAUTION:

- Align the upper end of coil spring ① with upper rubber seat ② as shown in the figure.



Upper end of coil spring at upper rubber seat

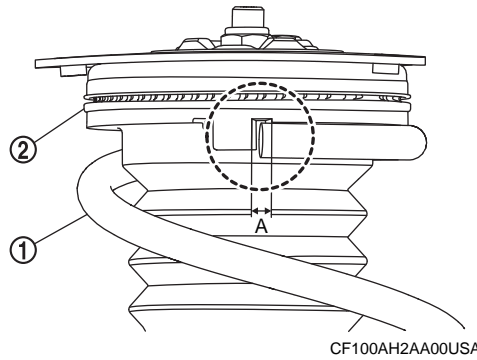

CF100AH2AA00USA



Lower end of coil spring at lower rubber seat

Dimension (A) : 5 mm (0.20 in) or less

8. Secure piston rod tip so that piston rod does not turn, then tighten piston rod lock nut with specified torque.

CAUTION:

Never reuse piston rod lock nut.

9. Gradually release a spring compressor (A) (commercial service tool), and remove coil spring.

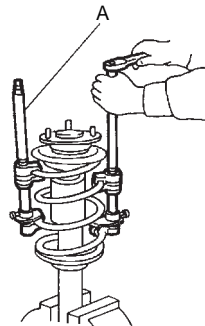

CF100AGYAA00USA

CAUTION:

Loosen while making sure coil spring attachment position does not move.

10. Remove the strut attachment (A) (SST: ST35652000) from strut assembly.

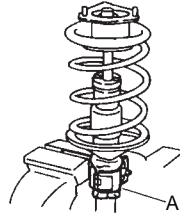

CF100AGXAA00USA

Inspection

INSPECTION AFTER DISASSEMBLY

Check the following items, and replace the parts if necessary.

Strut

- Strut for deformation, cracks or damage
- Piston rod for damage, uneven wear or distortion
- Oil leakage

Strut Mounting Insulator and Bound Bumper

Check strut mounting insulator and bound bumper for cracks, wear or damage.

Coil Spring

Check coil spring for cracks, wear or damage.

INSPECTION AFTER INSTALLATION

1. Check wheel sensor harness for proper connector. Refer to [FRONT WHEEL SENSOR](#).
2. Check wheel alignment. Refer to [WHEEL ALIGNMENT](#).
3. Adjust neutral position of steering angle sensor. Refer to Description [ADJUSTMENT OF STEERING ANGLE SENSOR NEUTRAL POSITION](#).

Disposal

1. Set strut assembly horizontally to the ground with the piston rod fully extracted.
2. Drill 2 – 3 mm (0.08 – 0.12 in) hole at the position (●) from top as shown in the figure to release gas gradually.

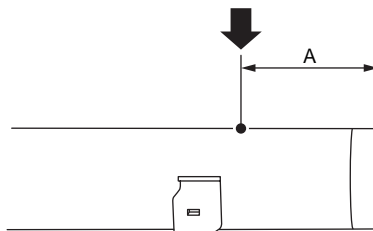

CF100AH3AA00USA

CAUTION:

- Wear eye protection (safety glasses).
- Wear gloves.
- Be careful with metal chips or oil blown out by the compressed gas.

**NOTE:**

- Drill vertically in this direction show by arrow.
- Directly to the outer tube avoiding brackets.
- The gas is clear, colorless, odorless, and harmless.

A : 20 – 30 mm (0.79 – 1.18 in)

3. Position the drilled hole downward and drain oil by moving the piston rod several times.

CAUTION:

Dispose of drained oil according to the law and local regulations.

TRANSVERSE LINK

Exploded View

SEC. 401

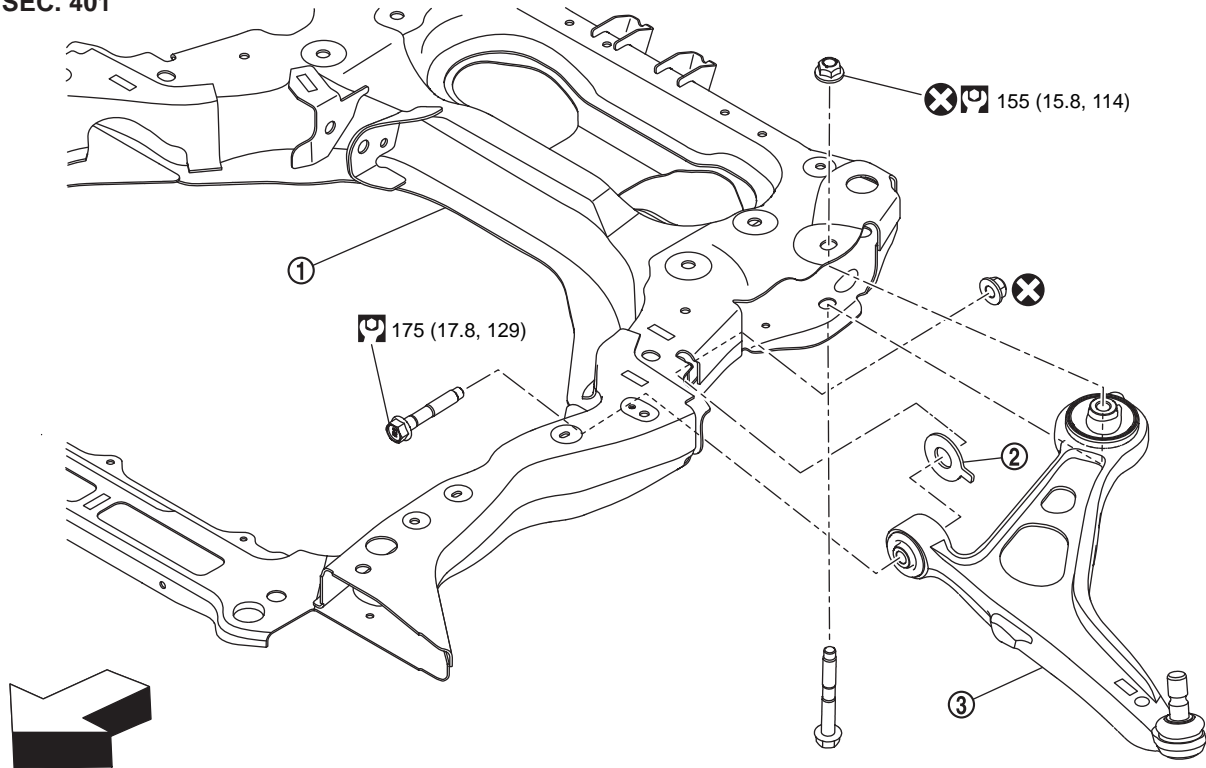

DF100AH4AA00USA

①	Front suspension member	②	Bush	③	Transverse link
←	: Vehicle front				
⊞	: N·m (kg·m, ft·lb)				
⊗	: Always replace after every disassembly.				

Removal and Installation

REMOVAL

1. Remove front suspension member. Refer to [FRONT SUSPENSION MEMBER](#).
2. Remove transverse link mounting bolts (A) and nuts (B), and then remove transverse link (1) from suspension member.

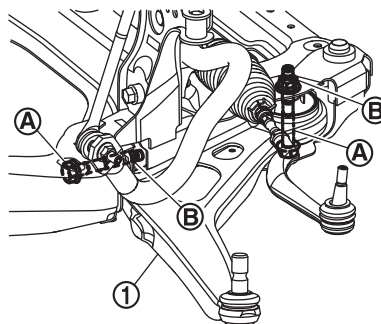

CF100AH5AA00USA

3. Perform inspection after removal. Refer to Inspection [TRANSVERSE LINK](#).

INSTALLATION

Note the following, and install in the reverse order of removal.

- Never reuse transverse link mounting nut.
- Perform final tightening of bolts and nuts at the vehicle installation position (rubber bushing), under unladen conditions with tires on level ground.
- Perform inspection after installation. Refer to Inspection [TRANSVERSE LINK](#).

Inspection

INSPECTION AFTER REMOVAL

Check the following items, and replace the parts if necessary.

Transverse Link

- Transverse link for deformation, cracks or damage.
- Check the bushing for complete separation. (If completely separated, inner metal can be pulled out from transverse link.)
- Ball joint boot for cracks or other damage, and also for grease leakage.

Swing Torque

1. Manually move ball stud to confirm it moves smoothly with no binding.
2. Move ball stud at least ten times by hand to check for smooth movement.
3. Hook a spring balance (A) at cutout on ball stud (B). Confirm spring balance measurement value is within specifications when ball stud begins moving.

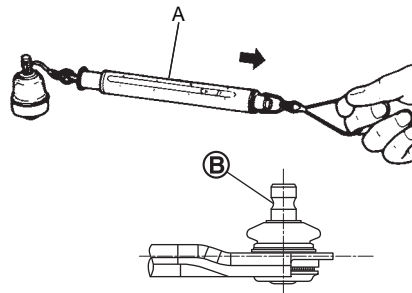

CF100AH6AA00USA

Swing torque : Refer to Ball Joint [SERVICE DATA AND SPECIFICATIONS \(SDS\)](#).

Measurement on spring balance : Refer to Ball Joint [SERVICE DATA AND SPECIFICATIONS \(SDS\)](#).

- If swing torque exceeds standard range, replace transverse link assembly.

Axial End Play

1. Move ball stud at least ten times by hand to check for smooth movement.
2. Move tip of ball stud in axial direction to check for looseness.
 - If there is axial end play, replace transverse link assembly.

INSPECTION AFTER INSTALLATION

1. Check wheel alignment. Refer to [WHEEL ALIGNMENT](#).
2. Adjust neutral position of steering angle sensor. Refer to Description [ADJUSTMENT OF STEERING ANGLE SENSOR NEUTRAL POSITION](#).

FRONT STABILIZER

Exploded View

SEC. 401

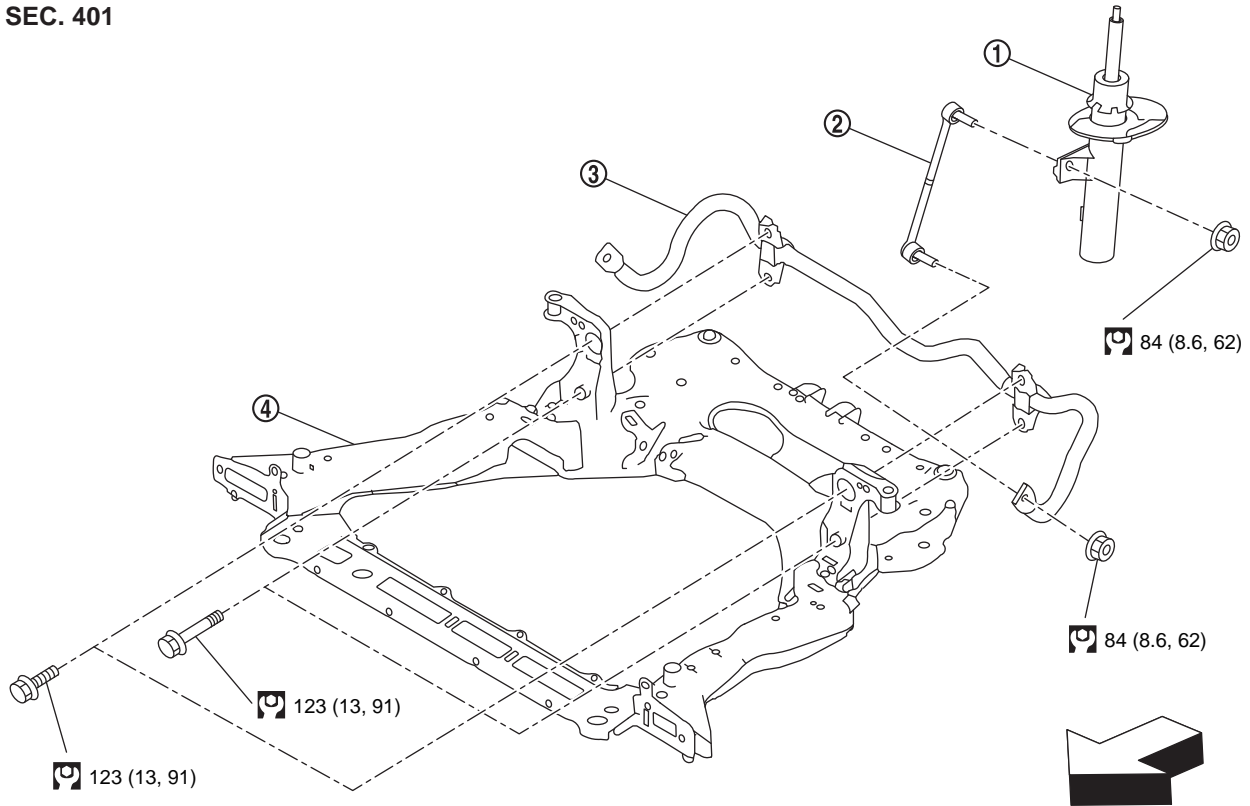

CF100AH7AA00USA

①	Strut	②	Stabilizer connecting rod	③	Stabilizer bar
④	Front suspension member				
←	: Vehicle front				
⊙	: N·m (kg·m, ft·lb)				

Removal and Installation

REMOVAL

- 1.Remove front suspension member. Refer to [FRONT SUSPENSION MEMBER](#).
- 2.Remove mounting bolts [Ⓐ] of stabilizer clamp, and then remove stabilizer clamp and stabilizer bushing from front suspension member.

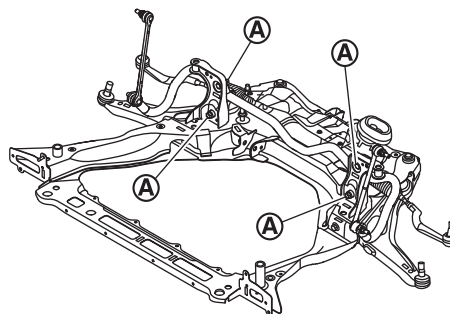

CF100AH8AA00USA

- 3.Remove stabilizer bar.
- 4.Perform inspection after removal. Refer to Inspection [FRONT STABILIZER](#).

INSTALLATION

Note the following, and install in the reverse order of removal.

- Install stabilizer bar as shown in the figure.

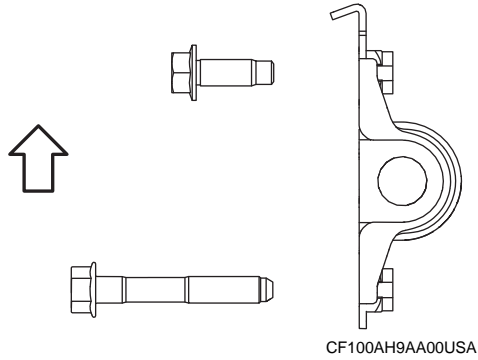

- When installing the stabilizer clamp mounting bolts, tighten in numerical order.

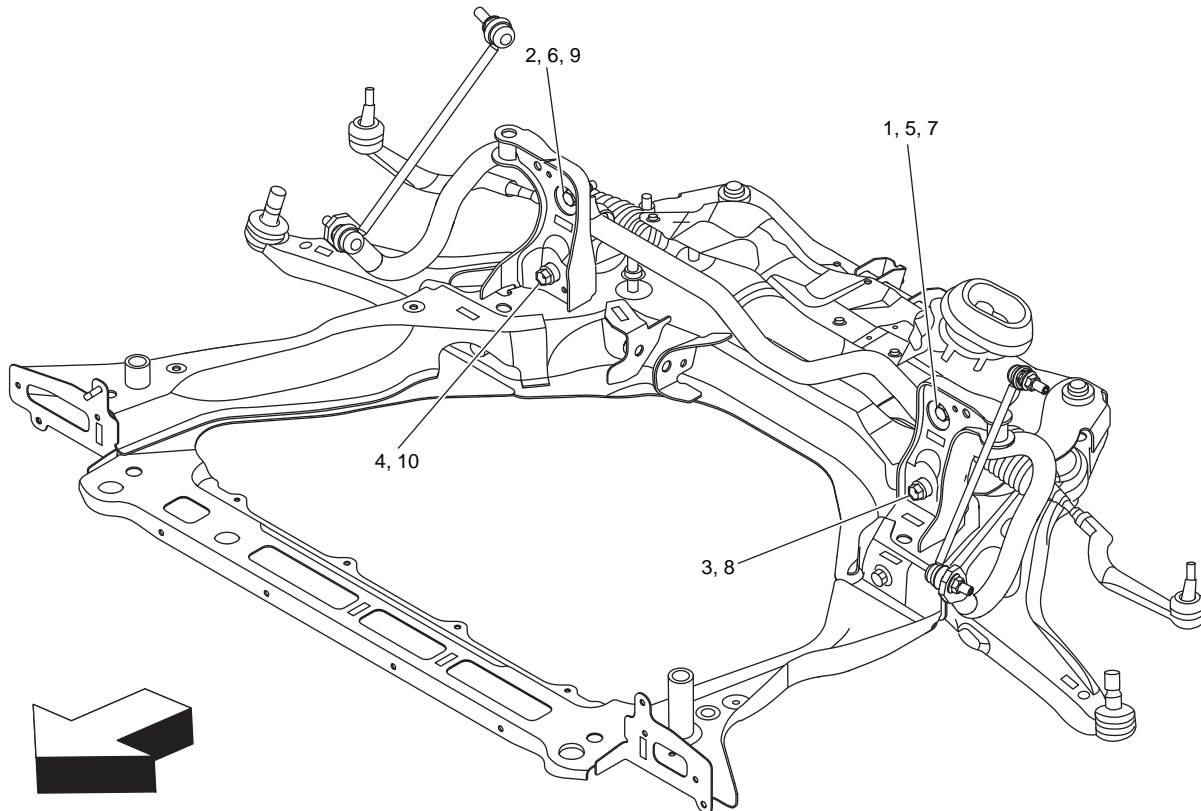

DF100AHAAA00USA

Temporary tightening (by hand)	: 1 – 2
Temporary tightening (by tool)	: 3→6
Final tightening (Specified torque)	: 7→10

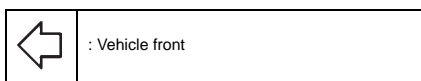

- To install stabilizer connecting rod ①, tighten the mounting nut with the hexagonal part ② on the stabilizer connecting rod side fixed.

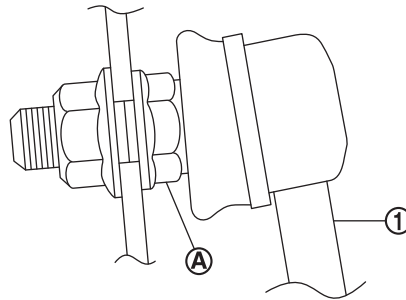

CF100AHBAA00USA

- Perform final tightening of bolts and nuts at the vehicle installation position (rubber bushing), under unladen conditions with tires on level ground.
- Perform inspection after installation. Refer to Inspection [TRANSVERSE LINK](#).

Inspection

INSPECTION AFTER REMOVAL

Check stabilizer bar, stabilizer connecting rod, stabilizer bushing and stabilizer clamp for deformation, cracks or damage. Replace it if necessary.

INSPECTION AFTER INSTALLATION

- Check wheel alignment. Refer to [WHEEL ALIGNMENT](#).
- Adjust neutral position of steering angle sensor. Refer to Description [ADJUSTMENT OF STEERING ANGLE SENSOR NEUTRAL POSITION](#).

FRONT SUSPENSION MEMBER

Exploded View

SEC. 401

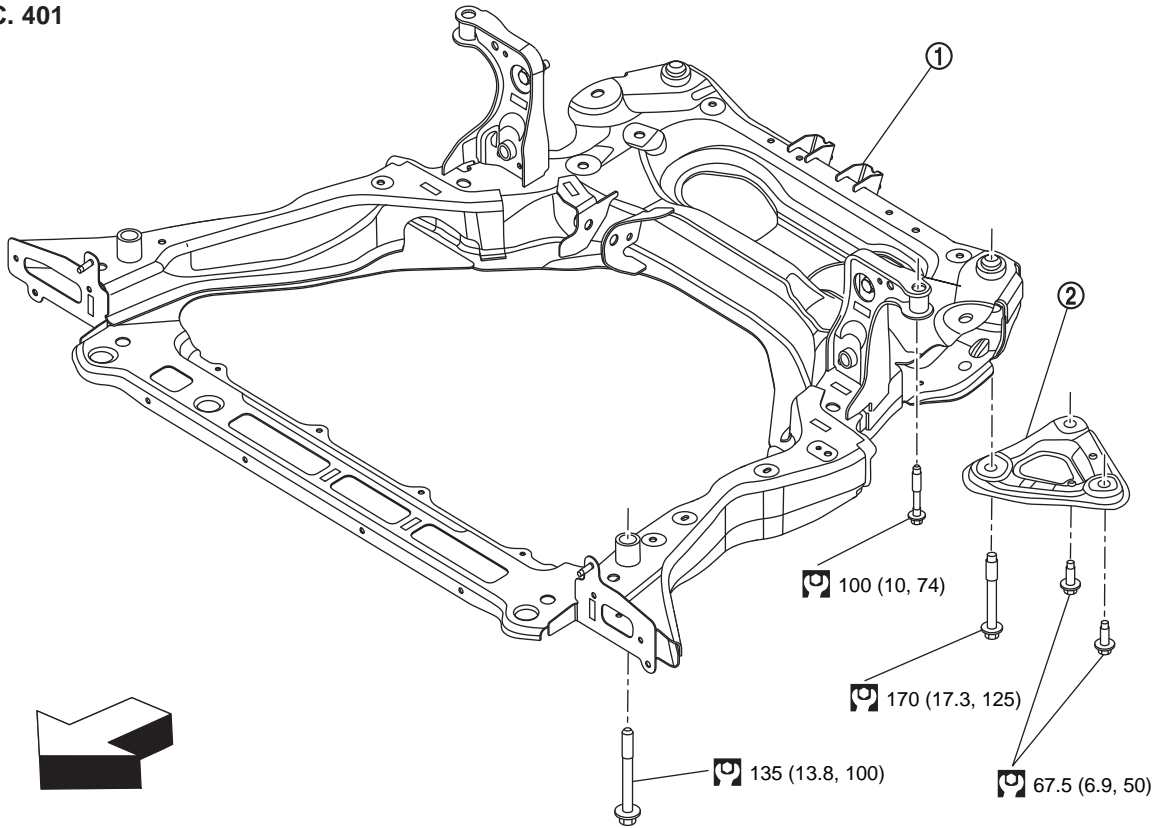

DF100AHCAA00USA

①	Front suspension member	②	Member stay		
←	: Vehicle front				
⊙	: N·m (kg-m, ft-lb)				

Removal and Installation

REMOVAL

1. Remove tires. Refer to Removal and Installation [ROAD WHEEL TIRE ASSEMBLY](#).
2. Remove engine under cover. Refer to [ENGINE UNDER COVER](#).
 - Remove front bumper fascia. Refer to [FRONT BUMPER](#).
 - Remove front bumper reinforcement. Refer to [FRONT BUMPER](#).
 - Remove clips **(A)**.

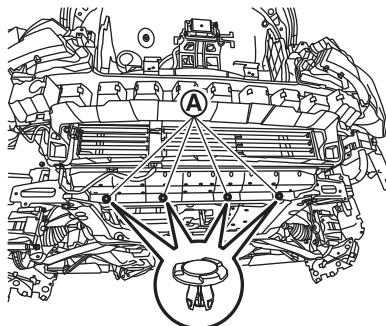

CF100AHDAA00USA

3. Separate stabilizer connecting rod (strut side) from strut. Refer to [FRONT STABILIZER](#).
4. Remove steering outer socket from steering knuckle. Refer to [STEERING GEAR AND LINKAGE](#).
5. Separate transverse link from steering knuckle. Refer to [TRANSVERSE LINK](#).
6. Disconnect steering gear and linkage harness connectors.
7. Remove rear torque rod. Refer to [ENGINE ASSEMBLY](#).
8. Remove front exhaust tube mounting bush. Refer to [EXHAUST SYSTEM](#).
9. Secure the radiator and condenser to the vehicle.
10. Set suitable jack under front suspension member.

CAUTION:

- At this step, the jack must be set only for supporting the removal procedure. For details on jacking up the vehicle, refer to [LIFTING POINT](#).
- Never damage the front suspension member with a jack.
- Check the stable condition when using a jack.

11. Remove member stay.
12. Remove front suspension member mounting bolts.
13. Gradually lower the jack to remove front suspension member from vehicle body.

CAUTION:

Operate while checking that jack supporting status is stable.

**NOTE:**

Remove suspension member with stabilizer bar and transverse link.

14. Remove the following parts.
 - Stabilizer bar: Refer to [FRONT STABILIZER](#).
 - Transverse link: Refer to [TRANSVERSE LINK](#).
 - Steering linkage. Refer to [STEERING GEAR AND LINKAGE](#).
15. Perform inspection after removal. Refer to Inspection [FRONT SUSPENSION MEMBER](#).

PARTS INFORMATION

Part Name	Part No.	Quantity	Remarks
<i>SPRING,FRONT</i>	<i>54010W480P</i>	<i>1</i>	<i>22MY 2WD/4WD 23-24MY 4WD</i>
<i>SPRING,FRONT</i>	<i>54010W490P</i>	<i>1</i>	<i>23-24MY 2WD</i>
BEARING,STRUT SUPPORT	4060A694	1	
PAD,SPRING UPPER	4040A586	1	
INSULATOR ASSY,STRUT	4060A693	1	
NUT HEX, FLG N-LOCK	AX000208	1	
<i>NUT S-LOCK, FLG</i>	<i>AX000209</i>	<i>2</i>	
NUT,FRONT AXLE	AX000793	1	
WASHER,STEELING GEAR	AX000220	1	
NUT,STEELING GEAR	AX000233	1	
NUT,SUSPENTION LOWER ARM	AX000270	2	

WARRANTY

This bulletin is supplied as technical information only and is not an authorization to repair. If an affected vehicle is reported with the described condition, diagnose the condition, repair as described in this bulletin, and submit a normal warranty claim using the information below.

Operation Code	Operation	Quantity	Work Time
<i>333211UH</i>	<i>Replacement (one side)</i>	<i>1</i>	<i>3.1H</i>
<i>333211UJ</i>	<i>Replacement (both sides)</i>	<i>1</i>	<i>4.6H</i>