



Service Bulletin

Bulletin No.: 18-NA-069

Date: April, 2025

TECHNICAL

Subject: Poor Engine Performance in Extremely Cold Weather Conditions for LFV Engines, Charge Air Cooler Icing - Malfunction Indicator Lamp (MIL) Illuminated - DTC P0299, P0234, P2227 and/or P00C7 Set

Brand:	Model:	Model Year:		VIN:		Engine:	Transmission:
		from	to	from	to		
Chevrolet	Malibu	2016	2025	—	—	1.5L (LFV)	—

Involved Region or Country	North America, China
Condition	<p>Some customers may comment on one or more of the following conditions when driving in extremely cold weather conditions (-18°C or less / 0°F or less):</p> <ul style="list-style-type: none"> • Loss of power • Hesitation on acceleration • Stalling condition • MIL Illuminated <p>Technicians may find one or more of the following DTCs set:</p> <ul style="list-style-type: none"> • P0299 • P0234 • P2227 • P00C7
Cause	This condition may be caused by ice accumulation in the charge air cooler (CAC), restricting air flow.
Correction	<p>Important: The DTCs and symptoms above are not exclusively related to freezing/icing conditions. Only follow this bulletin when the condition is directly correlated with extreme cold of -18°C or less / 0°F or less. System leaks should always be ruled out first for P0299. Signs of moisture will always be present in the CAC system and are not a reliable indicator of freezing/icing.</p> <p>Note: DO NOT replace the CAC if the service part is already installed.</p> <p>If any of the above conditions are present, allow time for possible ice buildup in the CAC to melt by allowing the vehicle to thaw in a warm environment, and drain the moisture from the CAC.</p> <p>If any of the above conditions are confirmed to be caused by freezing/icing, replace the original CAC with the new design wide fin service part. Confirmation should include:</p> <ul style="list-style-type: none"> • P0299 and/or P0234 present. • >100 mL (3.4 oz) moisture drained from thawed CAC. • Confirmed no leaks in CAC / CAC ducts. • Recent vehicle use in extreme cold (-18°C / 0°F or less). <p>If not recently performed, an oil change may be necessary to remove any moisture from the engine.</p> <p>If there is a check engine light with a P0234 or P0299 DTC during cold weather driving, refer to the following information:</p> <ul style="list-style-type: none"> - Frozen oil/water contaminant in the Turbocharger Wastegate Regulator Solenoid Valve (TCV) is often concurrent with vehicle operating conditions that cause CAC freezing. Cleaning or replacing the TCV solenoid should be performed in addition to CAC protection measures specified in this bulletin.

New winter grille covers have been released to prevent this issue from occurring in extreme cold weather (-18°C or less/0°F or less). The winter grille cover needs to be added to avoid the customer from returning with concerns related to charge air cooler icing. Please refer to the Parts Information section for the appropriate part number.

Perform the TCV thermo-wrap procedure below.

The winter grille cover can be installed by the technician during the repair procedure as listed in this bulletin. After the repair is complete, dealer service personnel must educate the customer on the installation and removal procedure of the winter grille cover. Installation instructions are included with the winter grille cover.

Note: The Engine Control Module calibration should be updated. The new calibration will enable a revised transmission shift pattern during cold weather operation, which does not use overdrive as frequently. As a result, *some customers* may notice elevated engine RPMs during highway operation. This operating mode will reduce the potential for ice to build up inside the charge air cooler, and the potential for setting P0299 or P0234 diagnostic codes. The customer must be *informed* by dealership personnel by explaining the new engine control module calibration and its *effects* on transmission shift patterns at highway speeds during cold weather to avoid a customer return to the dealership after the programming is completed.

Important: *The winter grille cover should be installed in the extreme cold weather and removed when the winter season changes. Additional covers and repeat installation are customer pay.*

Note: *Clean the surface before installing the winter grille cover.*

Important: Service agents must comply with all International, Federal, State, Provincial, and/or Local laws applicable to the activities it performs under this bulletin, including but not limited to handling, deploying, preparing, classifying, packaging, marking, labeling, and shipping dangerous goods. In the event of a conflict between the procedures set forth in this bulletin and the laws that apply to your dealership, you must follow those applicable laws.

Service Procedure

Important: Do Not replace the CAC ducts as part of this repair unless there is evidence of damage and/or a leak from the CAC ducts.

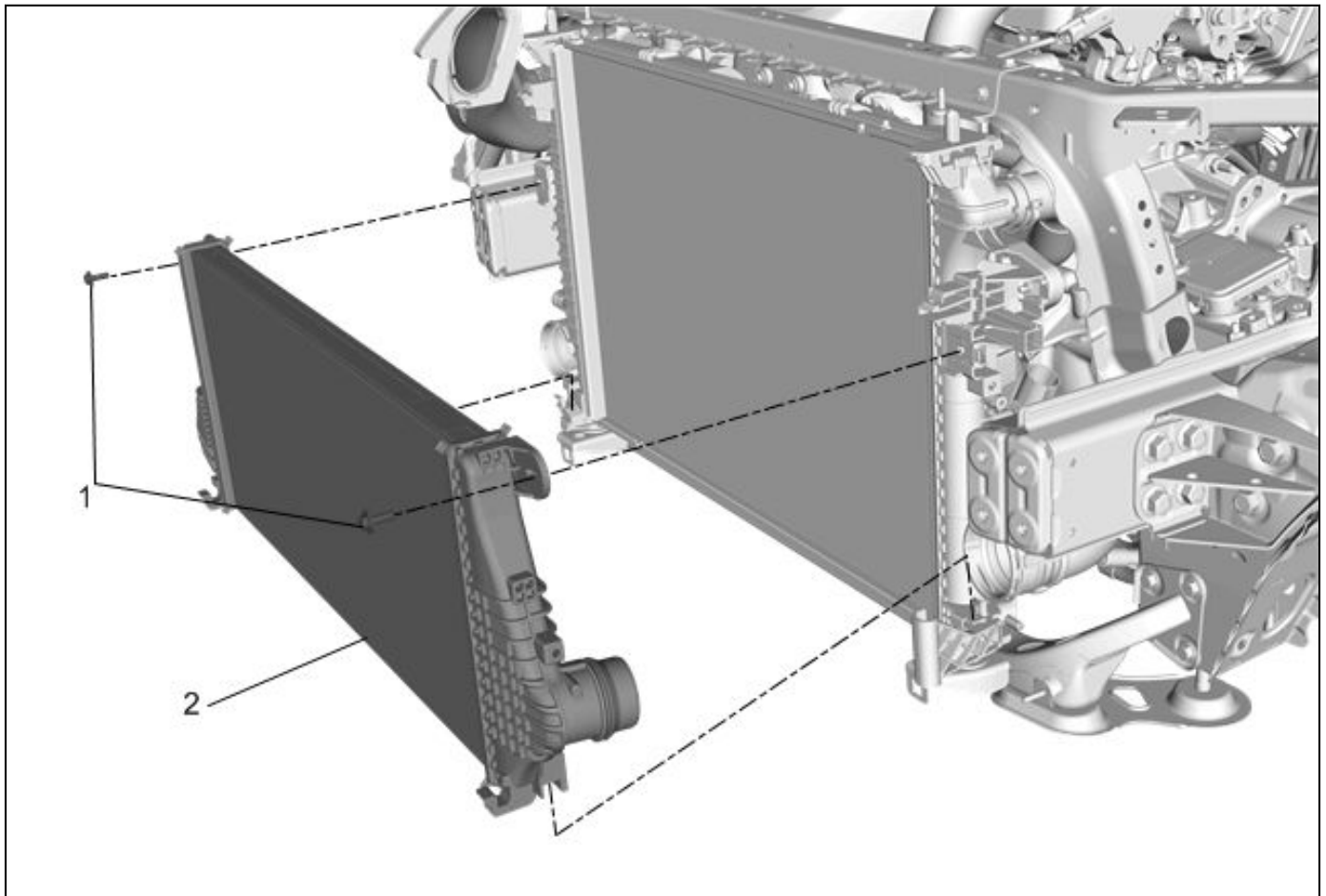

1. Install the CAC (2). Refer to *Charge Air Cooler Replacement* in SI.

Important: Do Not perform an oil change if the oil change was recently done.

- If the oil change was recently done and no signs of moisture have been confirmed, proceed to step 3.
 - If the oil change was not previously done or moisture has been found in the oil, proceed with procedure.
2. If required, perform an oil change. Refer to *Engine Oil and Oil Filter Replacement* in SI.

Turbocharger Wastegate Regulator Solenoid Valve (TCV) Thermo-Wrap

1. Remove the inlet duct/PCV tank to have better access to the TCV.

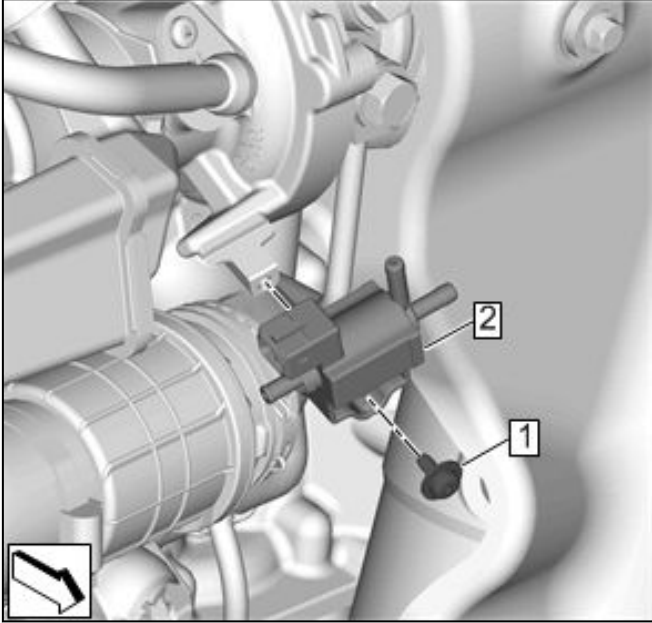

4823346

2. Remove the turbocharger wastegate regulator solenoid valve (TCV) (2). Refer to *Turbocharger Wastegate Regulator Solenoid Valve Replacement* in SI.
3. Drain the TCV by turning the valve upside down.

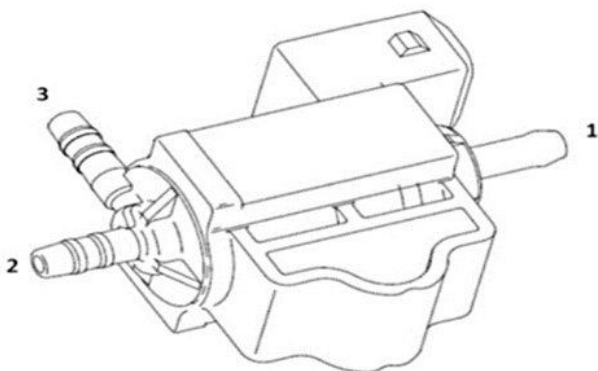

6055068

Note: Check port #2 to assure the spring gets lifted off the seat. This will be determined by the compressed air not dead heading when applied to port #2. When applying air to this port, a small amount of air should be observed at port #3 and even less air will be noticed at port #1. If this does not happen, the TCV plunger may have

hardened deposits from hot operating conditions which will impede TCV plunger movement, and the TCV should be replaced.

4. Using clean shop air regulated to 80-100 PSI, blow through all three ports (1, 2 & 3) for 5 seconds each.
⇒ Repeat step 4 twice.

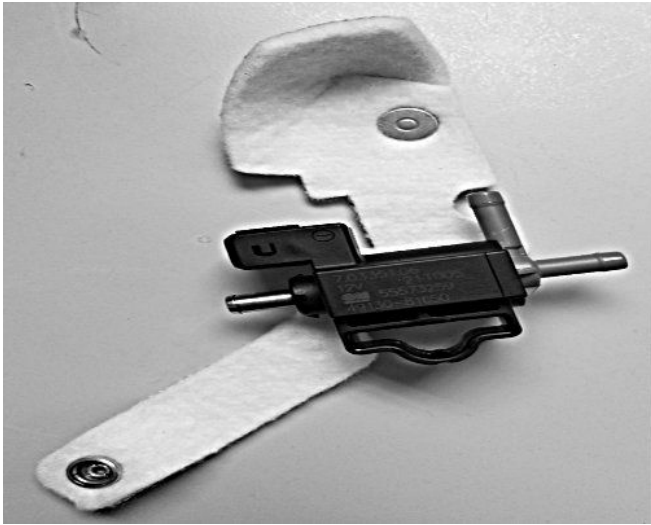

6055077

5. Prior to reinstalling the TCV, pre-position the thermal wrap. This will aid in installation of the wrap once the TCV is reinstalled.

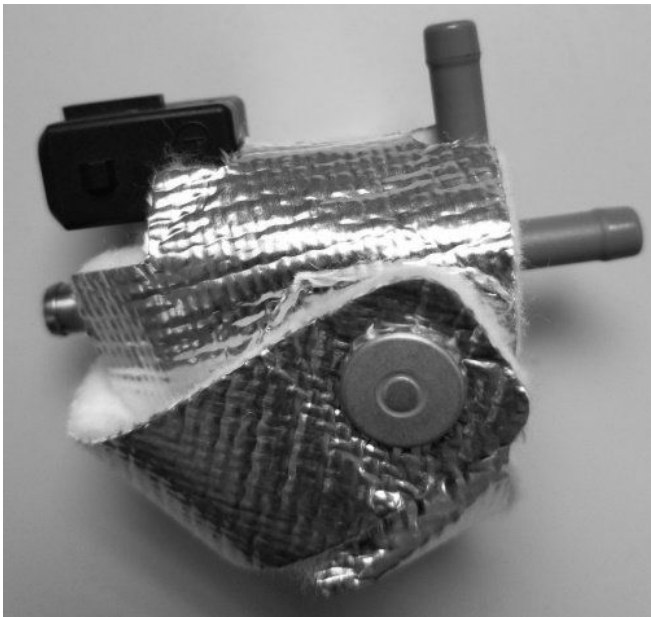

6046314

Note: The end result of the wrap will surround the TCV as shown in the graphic above.

6. Install the TCV. Refer to *Turbocharger Wastegate Regulator Solenoid Valve Replacement* in SI.



6046334

7. Once the mounting bolt and hoses are properly installed, pull the lower portion of the wrap upward and snap it into position.
8. Clear all DTCs using GDS and evaluate.

Turbocharger Air Pressure Sensor Inspection

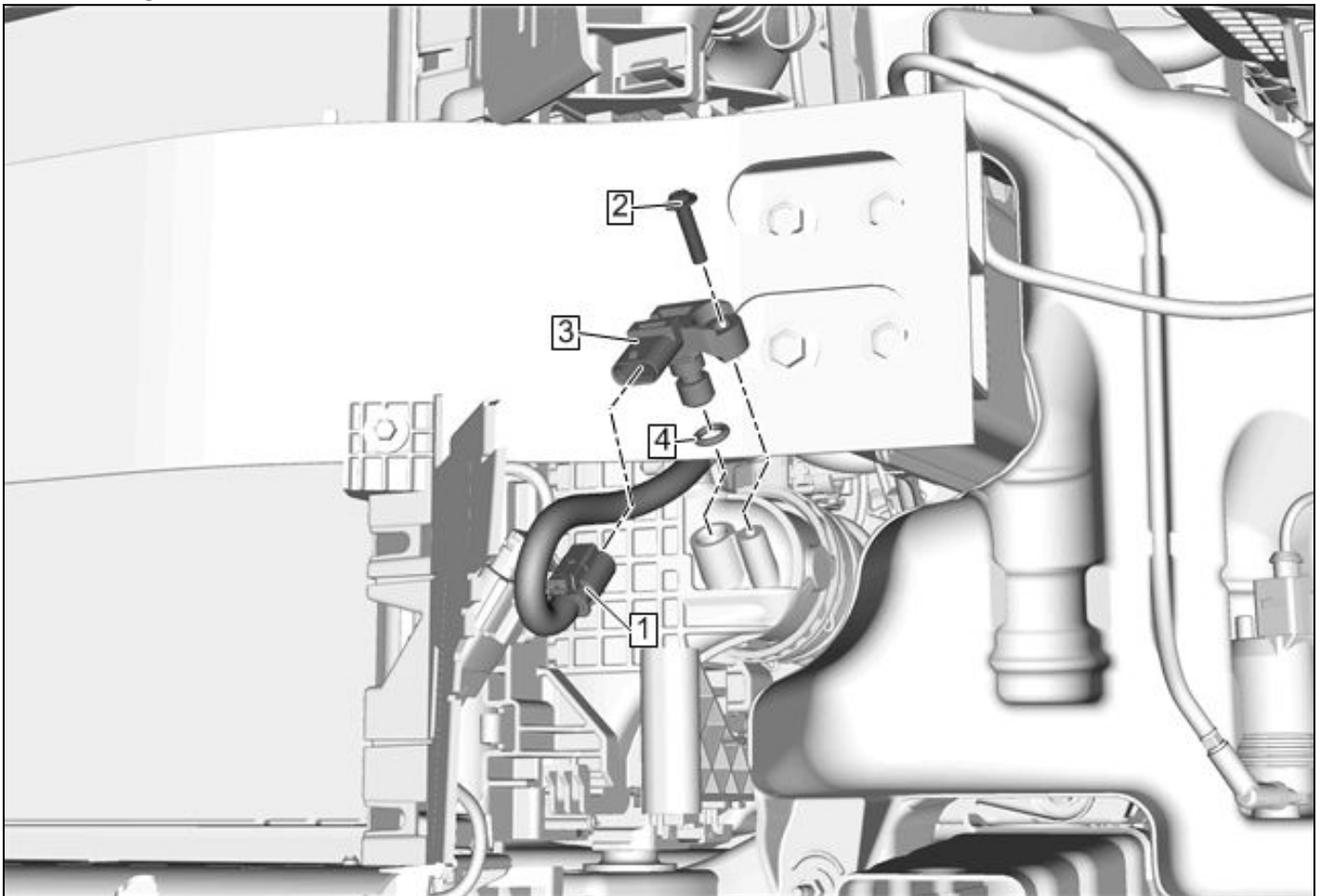

4233269

1. Remove the turbocharger air pressure sensor (3). Refer to *Turbocharger Air Pressure Sensor Replacement* in SI.



4910683

Important: Due to the sensitivity of the sensor, **Do Not** use any chemical cleaners including water and **Do Not** use compressed air to remove contaminates.

2. Inspect the sensor of any contaminates.

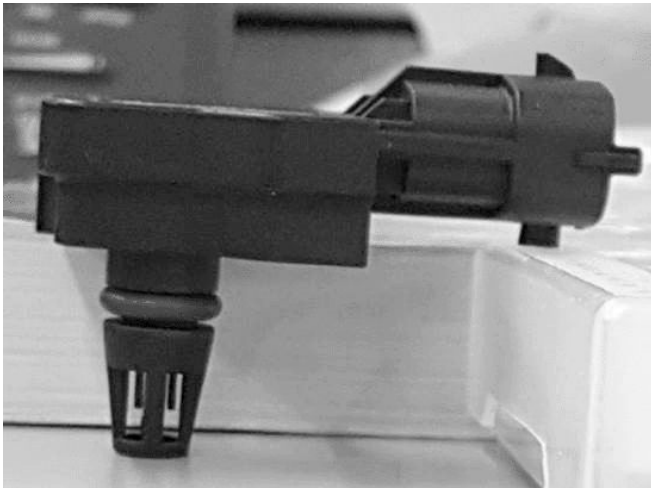

5020216

3. Allow time for any ice build-up to melt by placing the sensor port down.
4. Clean the sensor with a clean towel.
5. Install the sensor.

Front License Plate Mount Grille Cover Modification (2016-2018 Malibu with RPO-VK3)

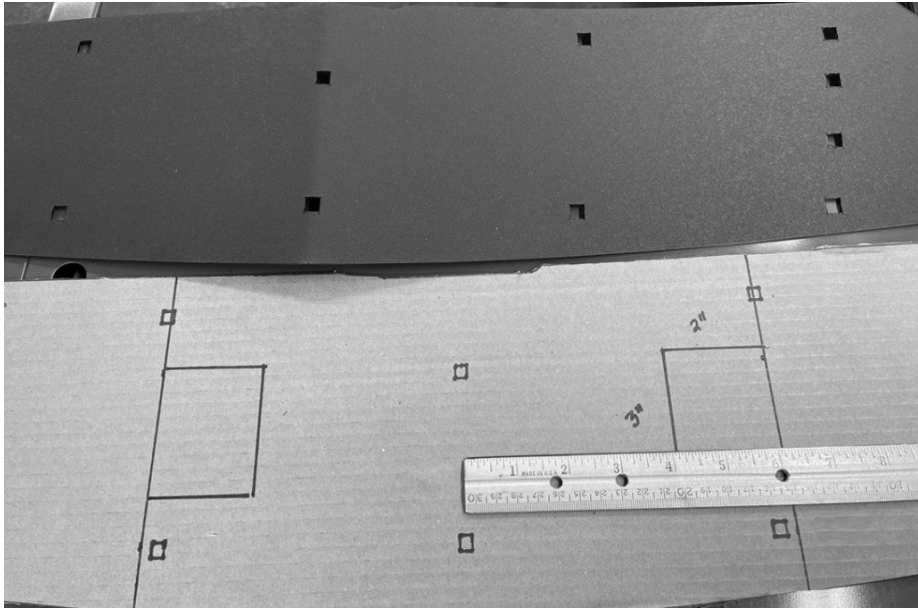

5982680

Important: It is recommended to practice on a piece of cardboard before modifying the plastic grille cover.

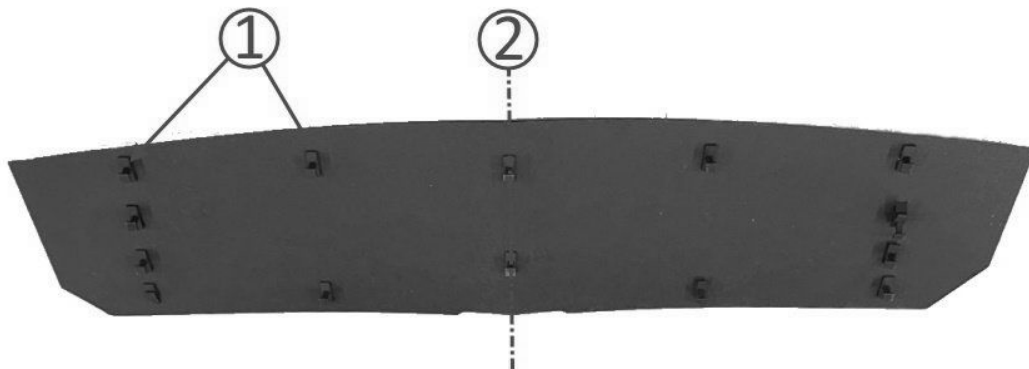

5982604

1. If installed, remove the license plate bracket.
2. Remove the mounting clips (1) from the cover.
3. Locate the center (2) on the grille cover.
4. Cut the cover in half.

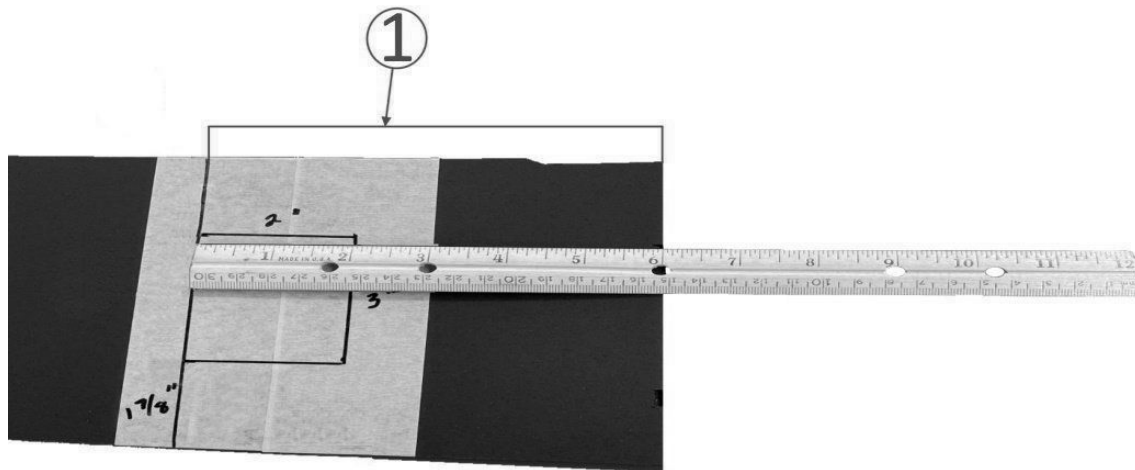

5989765

5. Apply painters tape across the entire height of the grille cover, approximately 17.8 cm (7 in) from the center of the cut end of the cover.
6. Measure 17.8 cm (6 in) across the top (1) of the cover and leave a mark.
7. Measure approximately 17.8 cm (6 in) across the center as indicated in the graphic above of the cover and leave a mark.
8. Draw a vertical line between the two marks.

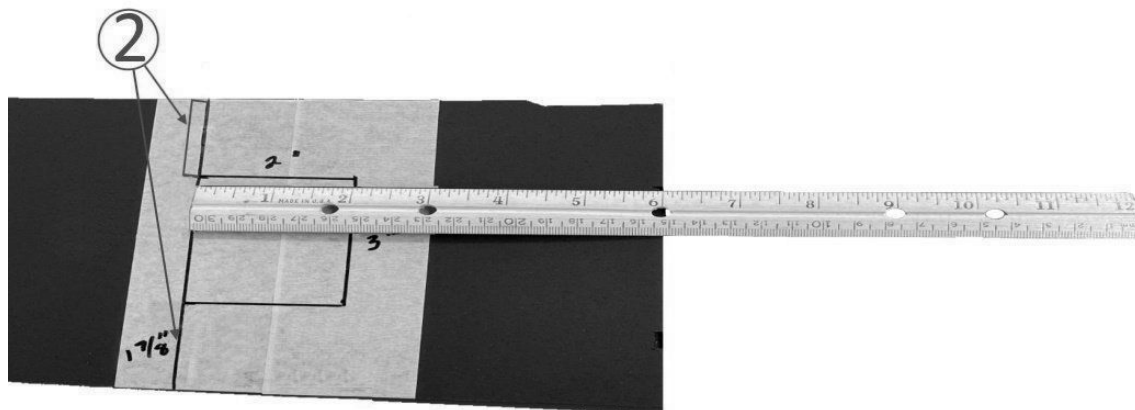

5989766

9. Measure **approximately 47.6 mm (1 7/8ths of an inch)** (2) from the top and from the bottom and leave a mark.

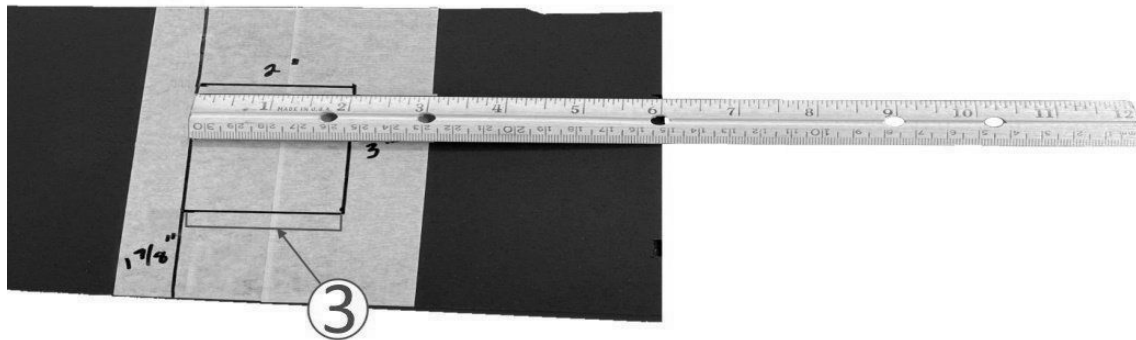

5989767

10. From the top and bottom marks, measure towards the center of the cover 50.8 mm (2 in) (3).

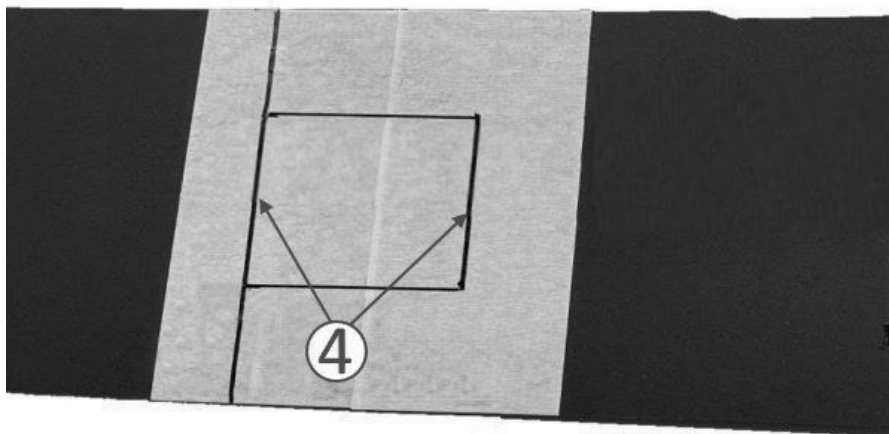

5989768

Note: The box created (4) should measure 50.8 mm x 76.2 mm (2 x 3 in).

11. Join the outer edges of the lines together to form a box.

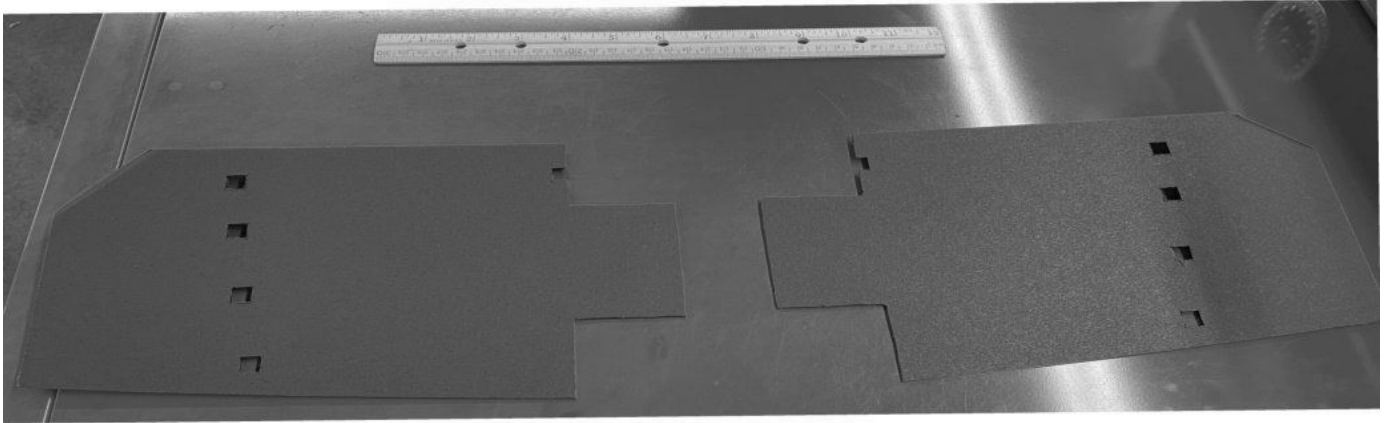

5982613

12. Utilizing a cutoff wheel or equivalent, cut along the outer edge of the lines.



5982625

13. Install the cover onto the grille utilizing the eight mounting clips.

14. install the license plate bracket.

Engine Control Module Programming for 2018–2022 Model Years

Important: Updated Engine Control Module calibration: The updated calibration will enable a revised transmission shift pattern during cold weather operation, which does not use overdrive as frequently. As a result, the customer may notice elevated engine RPMs during highway operation. This operating mode will reduce the potential for ice to build up inside the charge air cooler, and the potential for setting P0299 or P0234 diagnostic codes.

- Ensure the programming tool is equipped with the latest software and is securely connected to the data link connector. If there is an interruption during programming, programming failure or control module damage may occur.
- Stable battery voltage is critical during programming. Any fluctuation, spiking, over voltage or loss of voltage will interrupt programming. Install a GM Authorized Programming Support Tool to maintain system voltage. Refer to www.gmdesolutions.com for further information. If not available, connect a fully charged 12V jumper or booster pack disconnected from the AC voltage supply. DO NOT connect a battery charger.

- Follow the on-screen prompts regarding ignition power mode, but ensure that anything that drains excessive power (exterior lights, HVAC blower motor, etc) is off.
- Please verify that the radio time and date are set correctly before inserting USB drive into vehicle for programming, **otherwise an error will result.**
- Clear DTCs after programming is complete. Clearing powertrain DTCs will set the Inspection/Maintenance (I/M) system status indicators to NO.

Important: The service technician always needs to verify that the VIN displayed in the TLC left side drop down menu and the top center window match the VIN plate of the vehicle to be programmed prior to using Service Programming System 2 (SPS2) for programming or reprogramming a module.

- For the TLC application, service technicians need to always ensure that the power mode (ignition) is “ON” before reading the VIN from the vehicle’s VIN master module and that they do not select a VIN that is already in the TLC application memory from a previous vehicle.
- If the VIN that shows up in the TLC top center window after correctly reading the VIN from the vehicle does not match the VIN plate of the vehicle, manually type in the VIN characters from the vehicle VIN plate into the TLC top center window and use these for programming or reprogramming the subject module with the correct vehicle VIN and software and/or calibrations.
- The Engine Control Module (ECM) is the master module (for VIP vehicles) that TLC reads to determine the VIN of the vehicle. If the VIN read from the vehicle by TLC does not match the VIN plate of the vehicle, the ECM also needs to be reprogrammed with the correct VIN, software and calibrations that match the vehicle’s VIN plate.
- The Body Control Module (BCM) is the master module (for GEM vehicles) that TLC reads to determine the VIN of the vehicle. If the VIN read from the vehicle by TLC does not match the VIN plate of the vehicle, the BCM also needs to be reprogrammed with the correct VIN, software and calibrations that match the vehicle’s VIN plate.

Caution: Be sure the VIN selected in the drop down menu (1) is the same as the vehicle connected (2) before beginning programming.

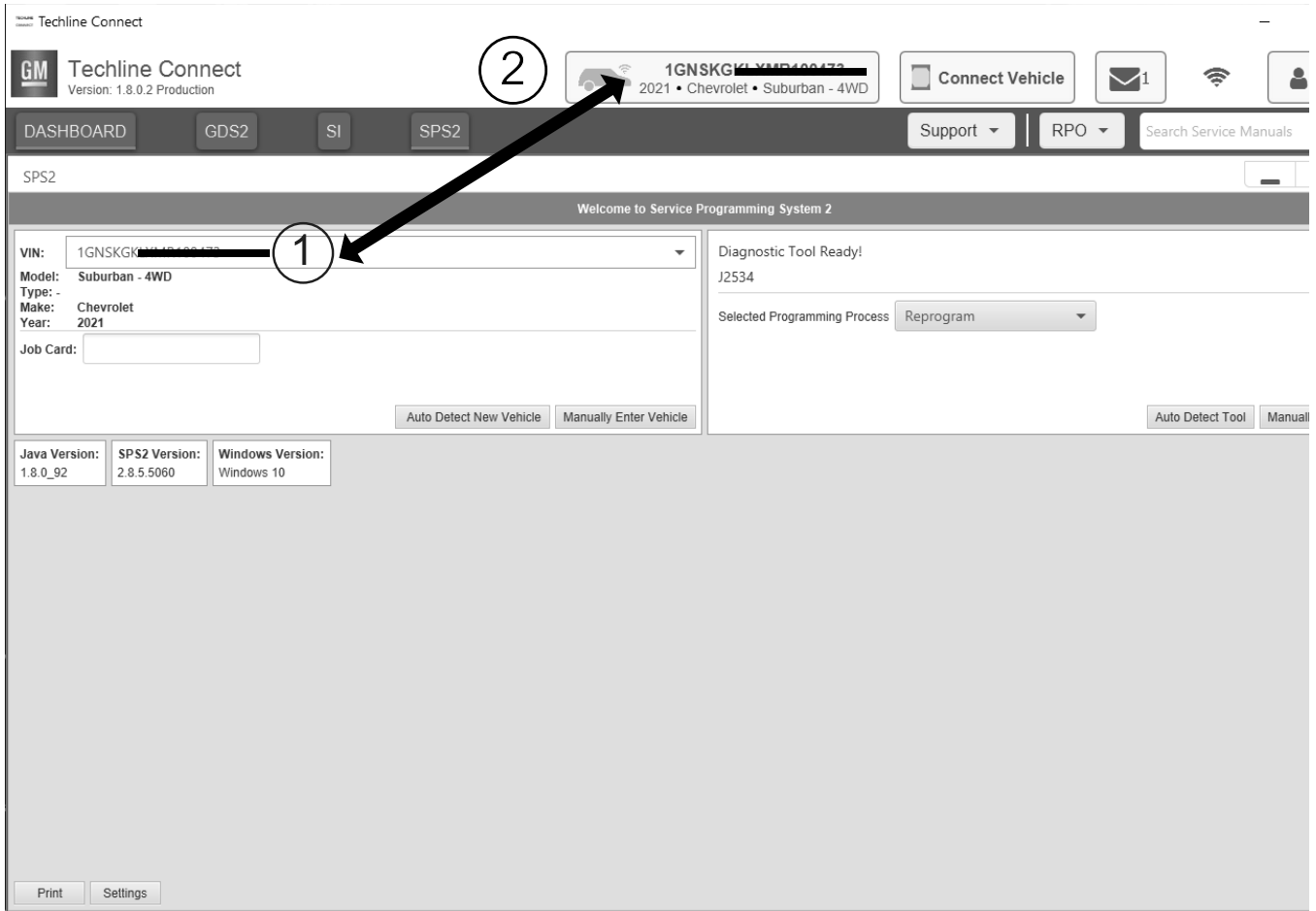

5743643

Important: If the vehicle VIN DOES NOT match, the message below will be shown.

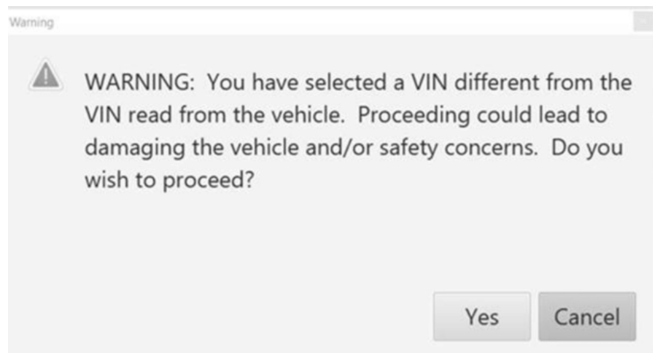

5877000

The screenshot shows the Techline Connect software interface. At the top, there is a navigation bar with 'DASHBOARD', 'GDS2', 'SI', and 'SPS2' buttons. A 'Support' dropdown and 'RPO' dropdown are also present. A search bar for 'Search Service Manuals' is on the right. Below the navigation bar, the 'SPS2' screen is active, displaying a 'Programming' table. A dialog box is overlaid on the table, displaying the message: 'M4521: You are attempting to reprogram with the same calibration. Select OK to continue, Cancel to Stop!'. The table has columns for 'Controller', 'ID', 'Current #', and 'Description'. The 'Description' column contains several entries that are partially obscured by redaction bars.

Controller	ID	Current #	Description
K17	1	84820771	
K17	2	84820790	
K17	3	84820797	84820797 Electronic Brake Diagnostic Calibration
K17	4	84820801	84820801 Function Enable Calibration
K17	5	84820808	84820808 Driver mode brake calibration
K17	6	84820819	84820819 Pre-Pressure Calibration
K17	7	84820825	84820825

5644477

Important: Techline Connect screen shown above.

Important: If the same calibration/software warning is noted on the TLC or SPS Summary screen, select OK and follow screen instructions. After a successful programming event, the WCC is located in the Service Programming System dialogue box of the SPS Summary screen. Document the WCC on the job card. No further action is required. Refer to the Warranty Information section of this bulletin.

1. Reprogram the ECM. Refer to *K20 Engine Control Module: Programming and Setup* in SI.

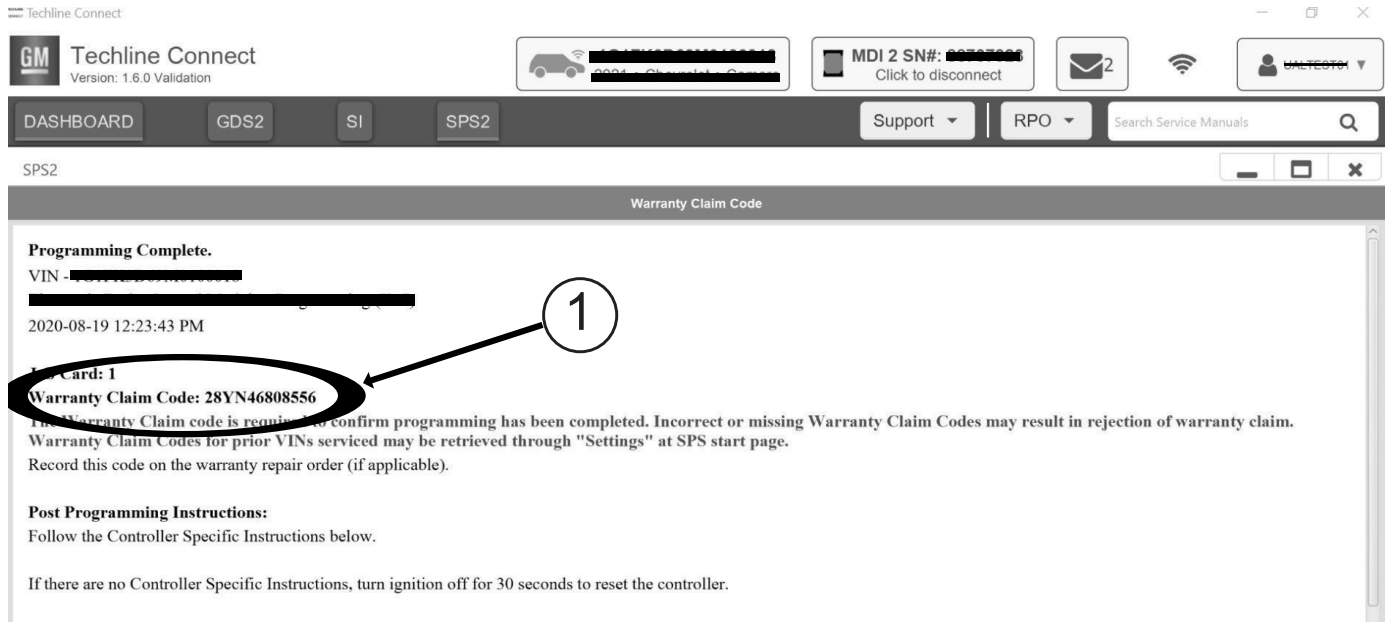

5644478

Note: The screenshot above is an example of module programming and may not be indicative of the specific module that is being programmed. Module selection and VIN information have been blacked out.

Important: To avoid warranty transaction rejections, you **MUST** record the warranty claim code provided on the Warranty Claim Code (WCC) screen shown above on the job card. Refer to callout 1 above for the location of the WCC on the screen.

- Record the Warranty Claim Code on the job card for warranty transaction submission.

Parts Information

Causal Part	Description	Part Number	Qty
N/A	COVER, GRILLE (Malibu 2016-2018)	86786758	1
N/A	COVER, GRILLE (Malibu 2019-2025 with no RPO VK3)	85666102	1
N/A	COVER, GRILLE (Malibu 2019-2025 with RPO VK3)	85666106	1
N/A	COOLER ASM-CHRG AIR	84768953	1
N/A	SHIELD ASM, TCV	25205589	1
N/A	Filter, Oil	Refer to the Electronic Parts Catalog (EPC).	
N/A	Oil		

Warranty Information

Important: The 2888378 Labor code for ECM reprogramming is covered under the E2 coverage and NOT Powertrain. Coverage code E2 applies for this module programming event. ECM reprogramming is covered for 8 years/80,000 miles (U.S.) or 8 years/130,000 km (Canada).

Note: Warranty Coverage Codes E, E1 apply to Labor Operation 4086058.

For vehicles repaired under the Powertrain coverage, use the following labor operation. Reference the Applicable Warranties section of Investigate Vehicle History (IVH) for coverage information.

Labor Operation	Description	Labor Time
4086058*	Charge Air Cooler Replacement	2.6 hrs
Add	To Recover and Recharge R-1234yf A/C System	1.2 hrs
Add	To Recover and Recharge R-134a A/C System	0.3 hr
Add	IAPT Inspection	0.2 hr
Add	Oil Change	0.3 hr
Add	Install Grille Cover	0.2 hr
Add	Grille Cover License Plate Modification	0.5 hr
Add	TCV Cleaning and Wrap Install	0.2 hr
2888378**	Engine Control Module Re-programming with SPS for 2018-2022 Malibu	0.3 hr

*This is a unique Labor Operation for bulletin use only.

Important: **To avoid warranty transaction rejections, carefully read and follow the instructions below:

- The Warranty Claim Code must be accurately entered in the "SPS Warranty Claim Code" field of the transaction.
- When more than one Warranty Claim Code is generated for a programming event, it is required to document all Warranty Claim Codes in the "Correction" field on the job card. Dealers must also enter one of the codes in the "SPS Warranty Claim Code" field of the transaction, otherwise the transaction will reject. It is best practice to enter the FINAL code provided by SPS2.

Warranty Claim Code Information Retrieval

If the SPS Warranty Claim Code was not recorded on the Job Card, the code can be retrieved in the SPS2 system as follows:

1. Open TLC/TIS on the computer used to program the vehicle.
2. Select and start SPS2.
3. Select Settings.
4. Select the Warranty Claim Code tab.

The VIN, Warranty Claim Code and Date/Time will be listed on a roster of recent programming events. If the code is retrievable, dealers should resubmit the transaction making sure to include the code in the SPS Warranty Claim Code field.

Version	13
Modified	<p>Released March 05, 2018</p> <p>Revised January 24, 2019 – Added the 2019 Model Year, China to Involved Region or Country, updated the Service Procedure and Warranty Information.</p> <p>Revised October 28, 2019 – Updated the Part Number in the Parts Information.</p> <p>Revised February 21, 2020 – Added the 2020 Model Year and updated the Correction information.</p> <p>Revised March 12, 2020 – Added an Important statement at the beginning of the Service Procedure advising not to replace the CAC ducts.</p> <p>Revised March 02, 2021 – Added the 2021 Model Year and updated the Warranty Information.</p> <p>Revised September 02, 2021 – Added the 2022 Model Year.</p> <p>Revised January 12, 2022 – Added information to reference PIP5812C and winter grille information to Correction section, grille cover for 2016–2018 Malibu to Parts Information section, Engine Control Module Programming section, updated the Warranty coverage information and added ECM Re-programming Labor Operation to Warranty Information.</p> <p>Revised February 22, 2022 – Added Front License Plate Mount Grille Cover Modification section, updated the Engine Control Module Programming procedure, updated the Winter Grille Cover Part Number in Parts Information section and updated the Important statement under Warranty Information.</p> <p>Revised May 24, 2022 – Changed P0236 to P0234, Added Turbocharger Wastegate Regulator Solenoid Valve (TCV) Thermo-Wrap section, changed RPO VKS to VK3 in</p>

Front License Plate Mount Grille Cover Modification title, removed first Caution in Engine Control Module Programming section and updated Parts and Warranty Information.

Revised October 11, 2022 – Added the first Important statement to the Correction section, the first Important statement above the Service Procedure, a graphic to Step 4 under Turbocharger Wastegate Regulator Solenoid Valve (TCV) Thermo-Wrap section, specific model years to Engine Control Module Programming title and a Note under Warranty Information.

Revised July 20, 2023 – Added the 2023 Model Year.

Revised April 09, 2025 – Added the 2024-2025 Model Years and updated the Correction, Parts and Warranty Information sections.

