

Air Compressor Discharge Line Blocked by Ice in Cold Weather

TSB-13-007-FTL

Creation Date: 2024-12-18

Last Revision Date: 2025-04-23

Engine or Vehicle Affected:

- ▶ eM2
 - ▶ eCascadia
-

Description of Revisions: This bulletin replaces the version dated 2024-12-18. The procedure to install the overflow valve splash cover has been added and the OWL tables have been revised.

Warranty applies to this described condition. See the warranty information at the end of this bulletin.

Described Condition

On eCascadia and eM2 vehicles, specific environmental conditions near freezing (both slightly above and below), where significant moisture and humidity are present, can lead to an ice blockage in the compressor discharge line overflow valve. As a result, the compressor will no longer build air and may blow air and mist oil out of a pressure relief valve on the compressor housing. This issue typically occurs upon startup of the vehicle but could also happen during operation under certain rare conditions. Follow the detailed procedure below to fix in the event this occurs, or if a vehicle is operating in conditions where this may occur.

Replacement of the Overflow Valve

1. Park the vehicle on a level surface, shut down the vehicle, and apply the parking brake. Chock the tires.

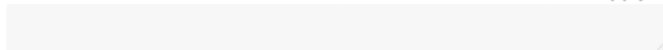

2. Drain the air from the vehicle.

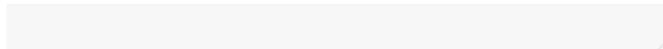

⚡ **Note:** The overflow valve is designed to maintain 100 psi (690 kPa) back-pressure in the compressor discharge line. This is to allow heat build-up in the compressor, and prevent moisture accumulation in the compressor oil.

3. Remove the two bolts from the top of the overflow valve. See Fig. 1.



08/28/2024

f130252

1. Bolts

2. Spring Chamber Cover

Fig. 1, Removing Bolts of the Overflow Valve

4. Replace the overflow valve.

5. Install the bolts. Tighten the bolts 62 to 80 lbf-in (700 to 904 N·cm).

6. Go to **Installation of the Overflow Valve Splash Cover** procedure.

Defrost-Clean-Dry-Reassembling the Valve

1. Park the vehicle on a level surface, shut down the vehicle, and apply the parking brake. Chock the tires.

2. Drain the air from the vehicle.

3. Remove the two bolts from the top of the overflow valve. See Fig. 1.

4. Remove the spring chamber cover. See Fig. 2.



08/28/2024

f130254

1. Spring Chamber Cover

2. Upper Spring seat

3. Spring

4. Bolt

5. Diaphragm

6. Valve

Fig. 2, Overflow Valve Assembly

5. Remove the spring, upper spring seat, plastic piston, and diaphragm.

● **Important:** DO NOT adjust the set screw on the top of the overflow valve spring chamber. This screw setting is precisely calibrated when the valve is manufactured, and changing the screw position will render the valve non-functional. See Fig. 3.

6. Defrost, clean, and dry the valve.



7. Install the spring, upper spring seat, plastic piston, and diaphragm inside the spring chamber cover.

8. Install the overflow valve.

9. Install the bolts. Tighten the spring chamber fasteners 62 to 80 lbf·in (700 to 904 N·cm).

10. Continue with **Installation of the Overflow Valve Splash Cover** procedure.

Installation of the Overflow Valve Splash Cover

For eCascadia vehicles

1. Park the vehicle on a level surface, shut down the vehicle, and apply the parking brake. Chock the tires.
2. Open the hood.
3. Install the splash cover on the overflow valve and secure the cover with a cable tie. See Fig. 4.

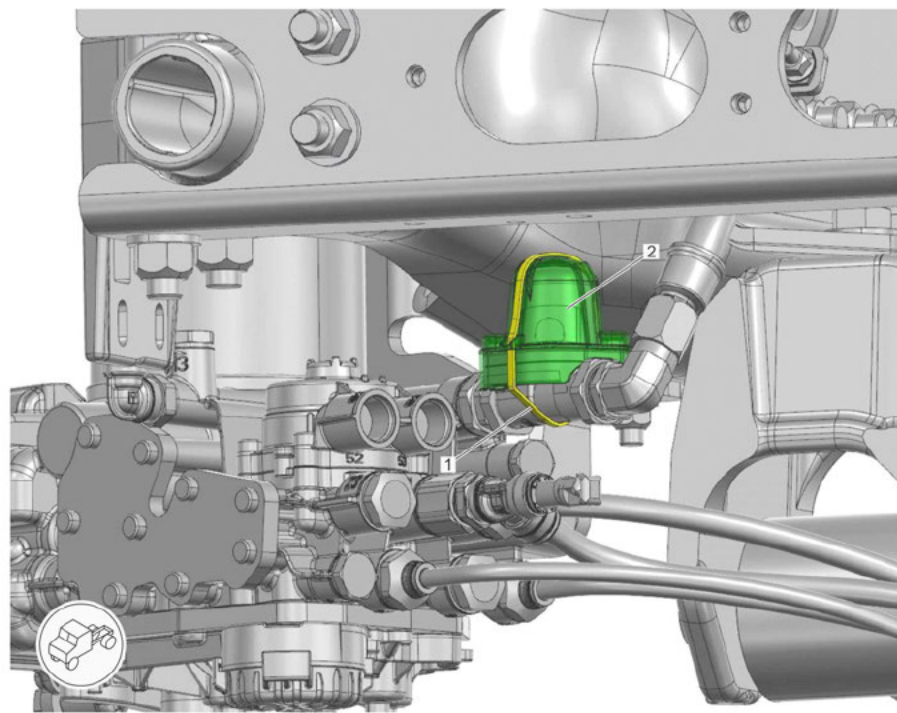

03/12/2025

f130257

1. Cable Tie

2. Splash Cover

Fig. 4, Overflow Valve Splash Cover

4. Close the hood.

For eM2 vehicles

1. Park the vehicle on a level surface, shut down the vehicle, and apply the parking brake. Chock the tires.
2. Open the hood.
3. Drain the air from the vehicle.
4. Disconnect the air lines from the Electronic Air Processing Unit (EAPU) to get access to the discharge line.
5. Disconnect the discharge line from the EAPU.
6. Remove the two inboard EAPU mounting fasteners and loosen the outboard fastener. See Fig. 5.

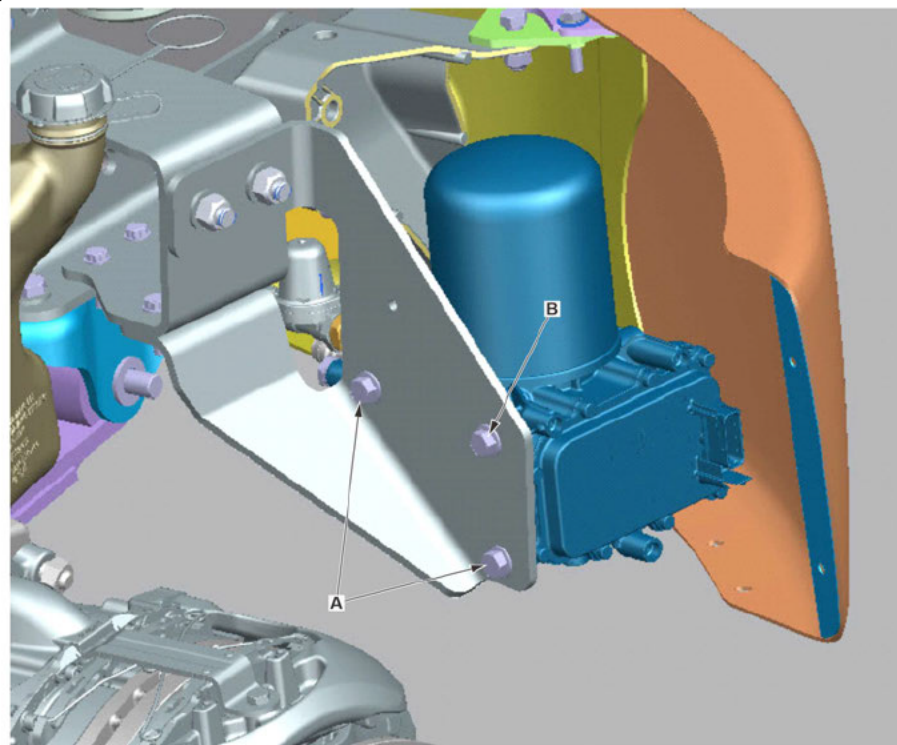

03/12/2025

f130258

- A. Remove the two inboard EAPU mounting fasteners.
- B. Loosen the outboard EAPU mounting fastener.

Fig. 5, EAPU Mounting Fasteners

7. Install the splash cover on the overflow valve and secure the cover with a cable tie. See Fig. 4.
8. Install the EAPU mounting fasteners.
9. Connect the discharge line to the EAPU. Tighten the fasteners 22 lbf-ft (30 N-m).
10. Connect the air lines to the EAPU.
11. Close the hood.

Warranty

This procedure is warrantable only if the described condition exists and the repair is performed within the applicable base or extended coverage warranty period. If a failure is not found, this procedure is considered preventive and warranty does not apply.

See Table 1 and Table 1 for OWL VMRS codes and labor allowance information. Enter this service bulletin number in the Service Bulletin # field.

Table 1, OWL VMRS Codes and Labor Allowance, eCascadia Vehicles

Primary Failed Part	Component Code	Cause Code	Correction Code	SRT Code	Description	Hours
A12-23236-017	013-018-024	64	03	3S8-5000A	OVERFLOW VALVE, COLD WEATHER BLOCKAGE, REPLACE (TSB13-007)	0.3
	013-018-024	64	02	3S8-5000B	OVERFLOW VALVE, COLD WEATHER BLOCKAGE, CLEAN (TSB13-007)	0.4
	013-009-023	64	17	3S8-5000D	COVER, DISCHARGE LINE, COLD WEATHER BLOCKAGE, INSTALL (TSB13-007)	0.1

Table 1, OWL VMRS Codes and Labor Allowance, eCascadia Vehicles

Table 2, OWL VMRS Codes and Labor Allowance, eM2 Vehicles

Primary Failed Part	Component Code	Cause Code	Correction Code	SRT Code	Description	Hours
A12-23236-017	013-018-024	64	03	3S8-5000A	OVERFLOW VALVE, COLD WEATHER BLOCKAGE, REPLACE (TSB13-007)	0.8
	013-018-024	64	02	3S8-5000B	OVERFLOW VALVE, COLD WEATHER BLOCKAGE, CLEAN (TSB13-007)	0.9
	013-009-023	64	17	3S8-5000D	COVER, DISCHARGE LINE, COLD WEATHER BLOCKAGE, INSTALL (TSB13-007)	0.4

Table 2, OWL VMRS Codes and Labor Allowance, eM2 Vehicles

Note:

- 013-019-001
- 013-018-001
- 013-018-024
- 013-018-030
- F37
- F38
- F40
- REPLACE
- REMOVE
- INSTALL
- CLEAN

Document Number: 0000134787

Topic Publication Date: 2025-04-29