

SF711 A

Creation Date: January 2025

Revision Date: April 2025

Subject: Automatic Low Voltage Disconnect Switch

Models Affected					
Make	Model	Model Yr. Start	Model Yr. End	Prod. Start Date	Prod. End Date
Thomas Built Buses	Saf-T-Liner C2 Jouley Electric School Buses	2021	2025	December 11, 2019	September 25, 2024

General Information

On behalf of the entity listed below, Daimler Truck North America LLC (DTNA), is initiating Field Service Campaign SF711 to modify the affected vehicles.

- Wholly owned subsidiary Thomas Built Buses (TBB)

REVISION: The parts table has been updated to include the mounting bracket and fasteners required for the Automatic Low Voltage Disconnect Switch (ALVD). Additionally, the work instructions have been revised to provide supplementary details for installing the ALVD mounting bracket and wheelchair lift.

PROBLEM: On the affected vehicles, the automatic low voltage disconnect switch was removed.

SOLUTION: The automatic low voltage disconnect switch will be installed.

There are approximately 1518 vehicles involved.

Additional Repairs

Dealers must complete all outstanding Recall and Field Service campaigns prior to the sale or delivery of a vehicle. A Dealer will be liable for any progressive damage that results from its failure to complete campaigns before sale or delivery of a vehicle.

Owners may be liable for any progressive damage that results from failure to complete campaigns within a reasonable time after receiving notification.

Please contact Warranty Campaigns for consideration of additional charges prior to performing the repair.

Work Instructions

Please refer to the attached work instructions.

Replacement Parts

If our records show your dealership has ordered any vehicle(s) involved in campaign number SF711, a list of the customers and vehicle identification numbers will be available on DTNA Portal. Please refer to this list when ordering parts for this recall.

SF711 A

Creation Date: January 2025

Revision Date: April 2025

Table 1 – Replacement Parts for SF711

Group	Part/Kit Description	Part Number	Qty
A	KIT,SVCE,MOD 290	A66-01179-290	1 ea.
A	BRKT-BAT DISC SW,EB2	06-96803-000	1 ea.
A	NUT-HEX,FLANGE,LOCK,5/16-18,ZINC	23-13861-105	2 ea.
A	WASHER-FLAT,STEEL,HARDENED,5/16 IN	23-09114-006	2 ea.
A	SCREW-CAP,HEX,5/16-18 X 1,GRADE 5	23-10744-100	2 ea.

Removed Parts

- For U.S. and Canadian Dealers, use the part disposition to determine how to manage removed parts (return, scrap, etc.). Dispositions are available at the date of the repair.
- For Export Dealers, destroy removed parts unless otherwise advised.

Claim Reimbursement - Labor Allowance

IMPORTANT: OWL must be viewed prior to performing the campaign to ensure the vehicle is involved and the campaign has not been previously completed. Also, check for a completion sticker prior to beginning work.

You will be reimbursed for your parts, labor, and handling (landed cost for Export Distributors) by submitting your claim through the Warranty system within 30 days of completing this campaign.

- In OWL, use the 'Retrieve' function and select the appropriate procedure. This will auto-populate the PFP, component code, replacement parts, cause, corrective action and SRT code.

Table 2 – Claim Reimbursement Table

Claim Type	Field Service Campaign
Campaign	SF711 Group A
VMRS Component Code	F99-999-005
Cause Code	A1 – Campaign
Primary Failed Part	25-SF711-000

Table 3 – Labor Allowance for SF711

Groups	Procedure	Time Allowed (hours)	SRT Codes	Corrective Action
Group A	Auto Low Voltage Disconnect Switch Installation	1.0	996-F160A	12-Repair Recall/Campaign

SF711 A

Creation Date: January 2025

Revision Date: April 2025

Claims for Credit

- Claim type is Field Service Campaign
- In the Campaign field, enter the campaign number and appropriate condition code (SF711 - A).
- In the Primary Failed Part field, enter 25-SF711-000.
- In the Parts section, enter the appropriate kit number as shown in the Replacement Parts Table.
- The VMRS Component Code is F99-999-005 and the Cause Code is A1 - Campaign.
- U.S. and Canada – Reimbursement for Prior Repairs. When a customer asks about reimbursement, please do the following:
 - Accept the documentation of the previous repair.
 - Make a brief check of the customer's paperwork to see if the repair may be eligible for reimbursement. (See the 'Copy of Owner Letter' section of this bulletin for reimbursement guidelines.)
 - Submit an OWL Recall Pre-Approval Request for a decision.
 - Include the approved amount on your OWL claim in the Other Charges section.
 - Attach the documentation to the pre-approval request.
 - If approved, submit a 'based on claim' for the pre-approval.
 - The Dealer is required to reimburse the customer the appropriate amount.

IMPORTANT: OWL must be viewed prior to performing the campaign to ensure the vehicle is involved and the campaign has not been previously completed. Also, check for a completion sticker prior to beginning work.

U.S. and Canadian dealers, contact the Warranty Campaigns Department via Web inquiry at DTNAPortal.com/WSC, if you have any questions or need additional information. Export distributors, submit a Web inquiry or contact your International Service Manager.

U.S. and Canadian Dealers: To return excess kit inventory related to this campaign, U.S. dealers must submit a Parts Authorization Return (PAR) to the Memphis PDC. Canadian dealers must submit a PAR to their facing PDC. All kits must be in resalable condition. PAR requests must include the original purchase invoice number. Export Distributors: Excess inventory is not returnable.

The letter notifying U.S. and Canadian vehicle owners is included for your reference.

Please note that the National Traffic and Motor Vehicle Safety Act, as amended (Title 49, United States Code, Chapter 301), requires the owner's vehicle(s) be corrected within a reasonable time after parts are available to you. The Act states that failure to repair a vehicle within 60 days after tender for repair shall be prima facie evidence of an unreasonable time. However, circumstances of a particular situation may reduce the 60-day period. Failure to repair a vehicle within a reasonable time can result in either the obligation to (a) replace the vehicle with an identical or reasonably equivalent vehicle, without charge, or (b) refund the purchase price in full, less a reasonable allowance for depreciation. The Act further prohibits dealers from selling a vehicle unless all outstanding recalls are performed. Any lessor is required to send a copy of the recall notification to the lessee within 10 days. Any subsequent stage manufacturer is required to forward this notice to its distributors and retail outlets within five working days.

SF711 A

Creation Date: January 2025

Revision Date: April 2025

Copy of Notice to Owners

Subject: Automatic Low Voltage Disconnect Switch

Daimler Truck North America LLC (DTNA), on behalf of its wholly owned subsidiary, Freightliner Custom Chassis Corporation, and Thomas Built Buses is initiating Field Service Campaign SF711 to modify specific Thomas Built Buses Saf-T-Liner C2 Jouley electric school buses, manufactured December 11, 2019, through September 25, 2024.

On the affected vehicles, the automatic low voltage disconnect switch was removed.

The automatic low voltage disconnect switch will be installed.

Please contact an authorized DTNA dealer to arrange to have the campaign performed and to ensure that parts are available at the dealership. The campaign will take approximately one hour and will be performed **free of charge**. To locate an authorized dealer, search online at Daimler-TruckNorthAmerica.com/Contact-us. Scroll down to "Locate a Dealer" and select the appropriate brand.

This Field Service Campaign will **terminate on January 31st, 2026**. Please make sure the campaign is completed prior to this date. Work completed after this date will be done at the customer's expense.

As stated in the terms of your express limited warranty, Daimler Truck North America LLC will not pay for any damage caused by failure to properly maintain your vehicle. Daimler Truck North America LLC considers the work necessary under this campaign to be proper maintenance and will, therefore, not pay for any damage to your vehicle caused by your failure to have the repairs that are the subject of this campaign performed in a reasonable time.

Contact the Warranty Campaigns Department at (800) 547-0712, from 7 a.m. to 4 p.m. Pacific Time, Monday through Friday, e-mail address: dtna-war-campaigns@daimlertruck.com, or the Customer Assistance Center at (800) 385-4357, if you have any questions or need additional information.

WARRANTY CAMPAIGNS DEPARTMENT

Enclosure

SF711 A

Creation Date: January 2025

Revision Date: April 2025

Work Instructions

Subject: Automatic Low Voltage Disconnect Switch

Models Affected					
Make	Model	Model Yr. Start	Model Yr. End	Prod. Start Date	Prod. End Date
Thomas Built Buses	Saf-T-Liner C2 Jouley Electric School Buses	2021	2025	December 11, 2019	September 25, 2024

Installation of the Automatic Low-Voltage Disconnect (ALVD) Switch

REVISION: The parts table has been updated to include the mounting bracket and fasteners required for the Automatic Low Voltage Disconnect Switch (ALVD). Additionally, the work instructions have been revised to provide supplementary details for installing the ALVD mounting bracket and wheelchair lift.

For vehicles in SF711A, the FL968 repair must be completed beforehand if the vehicle is part of the FL968 Automatic Low Voltage Disconnect Switch affected population.

Has the FL968 repair been completed on the vehicle?

YES → Proceed to the steps below.

NO → FL968 must be completed per the work instructions provided in that campaign before proceeding with the steps below.

1. Park the vehicle on a level surface, place the vehicle in neutral, shut down the vehicle, and set the parking brake. Chock the tires.
2. Turn the manual 12V battery cut-off switch to the OFF position.
3. Slide out the battery tray located in the battery box.

SF711 A

Creation Date: January 2025

Revision Date: April 2025

4. Loosen the fastener and disconnect the ground cable terminal, items 4 and 3 in **Fig. 1**, from the 12V battery.
5. Loosen the fastener and disconnect the positive cable terminal, items 2 and 1 in **Fig. 1**, from the 12V battery.

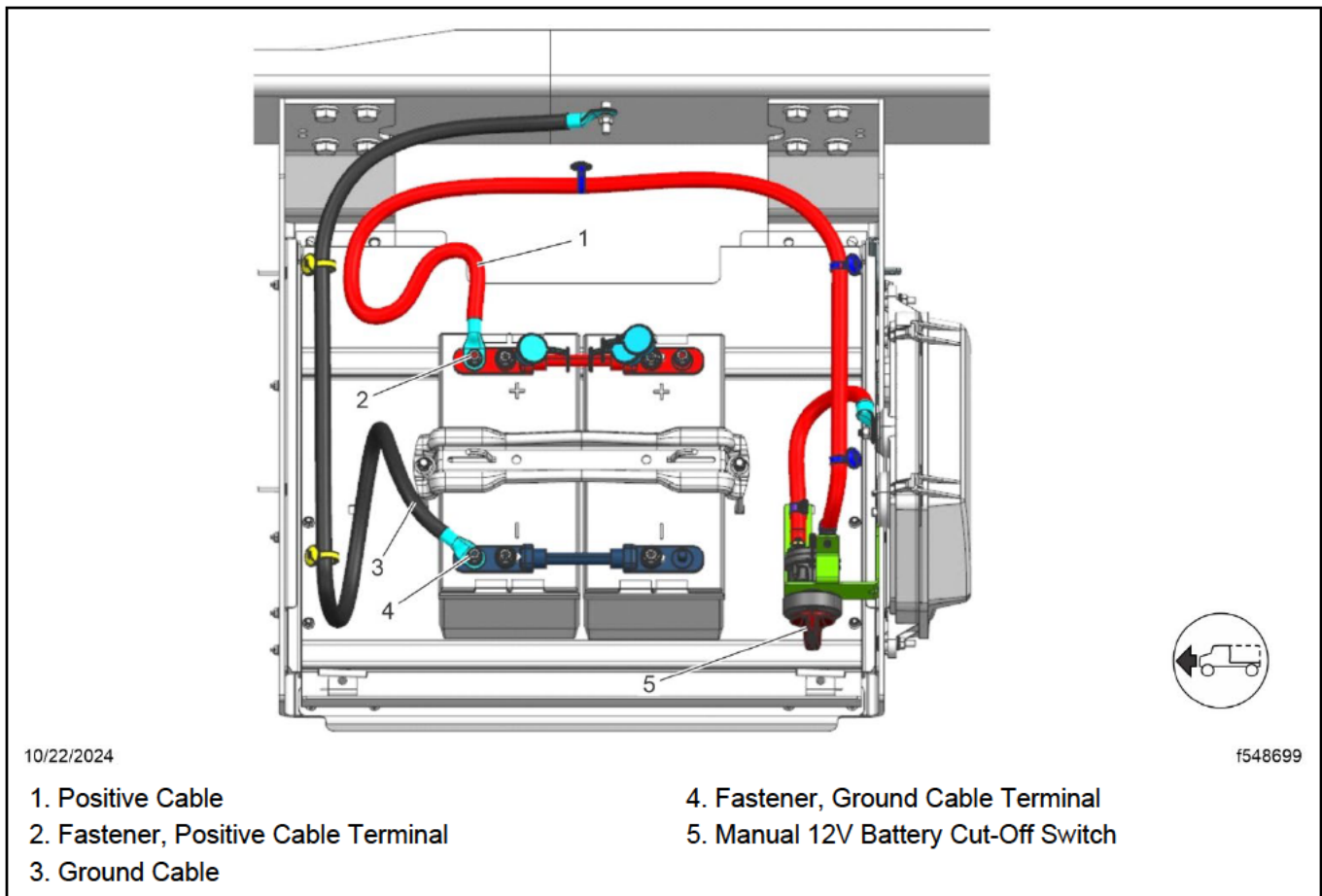

Fig. 1, Disconnecting the 12V Battery Terminals

SF711 A

Creation Date: January 2025

Revision Date: April 2025

6. Loosen the fastener and disconnect the Variable Frequency Device (VFD) power cable, items 2 and 3 in **Fig. 2**, from the 12V battery.
7. Loosen the fasteners, item 4 in **Fig. 2**, that keep the battery hold-down bracket in place, and remove the battery bracket.
8. Remove the 12V batteries from the slide-out tray to gain clearance.
9. Remove the VFD power cable clipping points, shown as item 1 in **Fig. 2**.

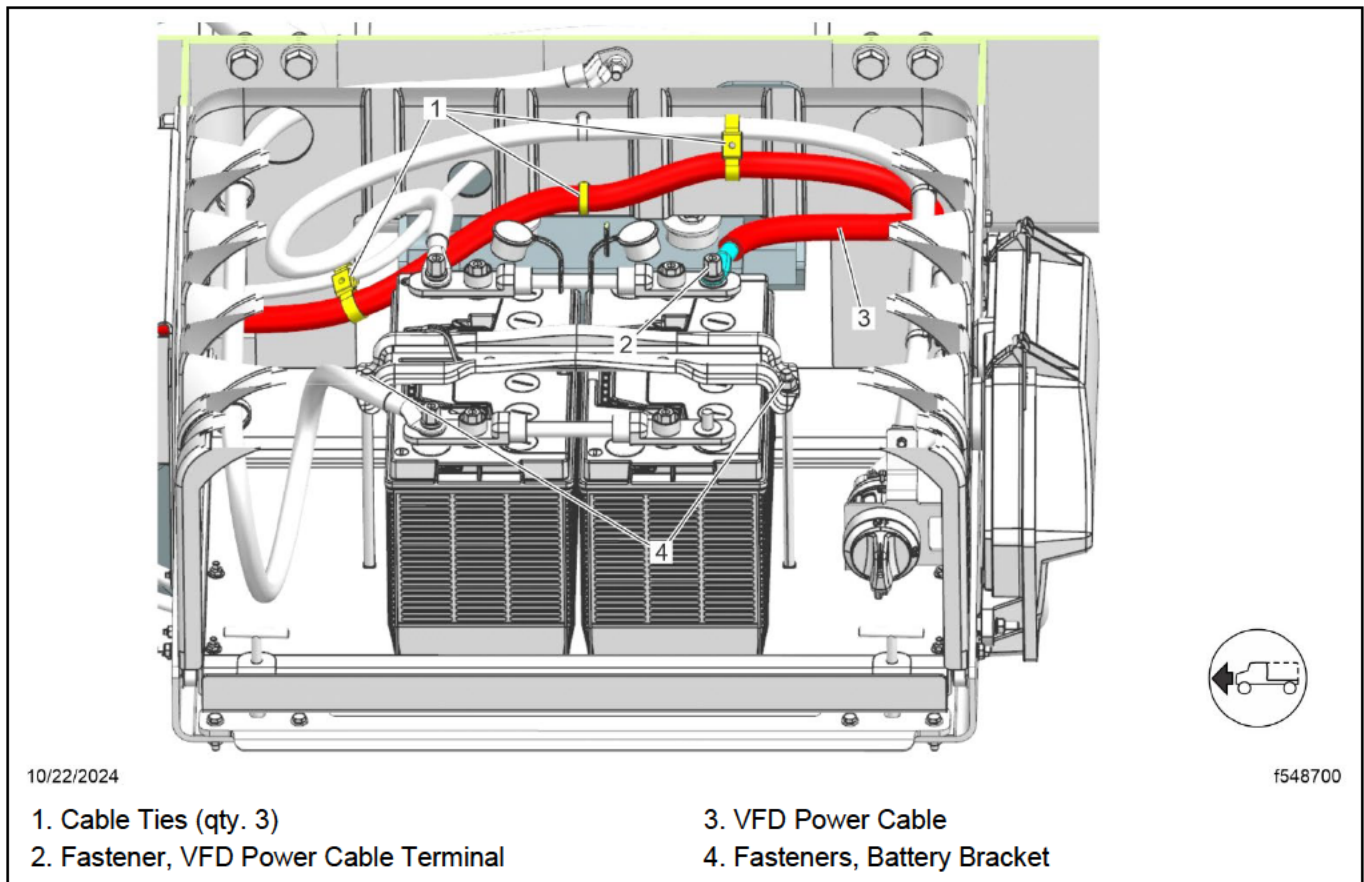

Fig. 2, Disconnecting the VFD Power Cable

10. Remove the clipping points from the power cable (A06-36356-056) connected to the manual battery cut-off switch.

SF711 A

Creation Date: January 2025

Revision Date: April 2025

11. Remove the fastener and disconnect the power cable (A06-36356-056) from the manual battery cut-off switch. See Fig. 3.

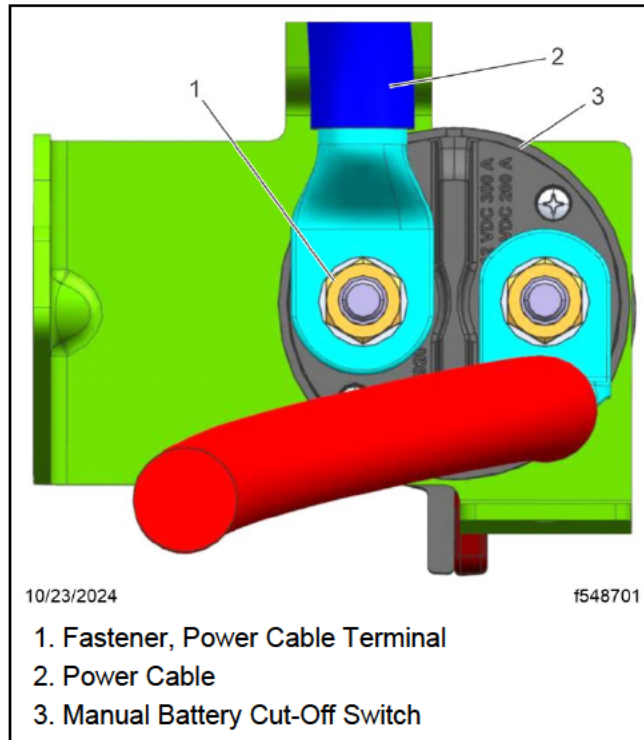

Fig. 3, Disconnecting the Power Cable from the Manual Battery Cut-Off Switch

SF711 A

Creation Date: January 2025

Revision Date: April 2025

12. Disconnect the harness branch terminal from the manual battery cut-off switch and remove the cable tie. See [Fig. 4](#).

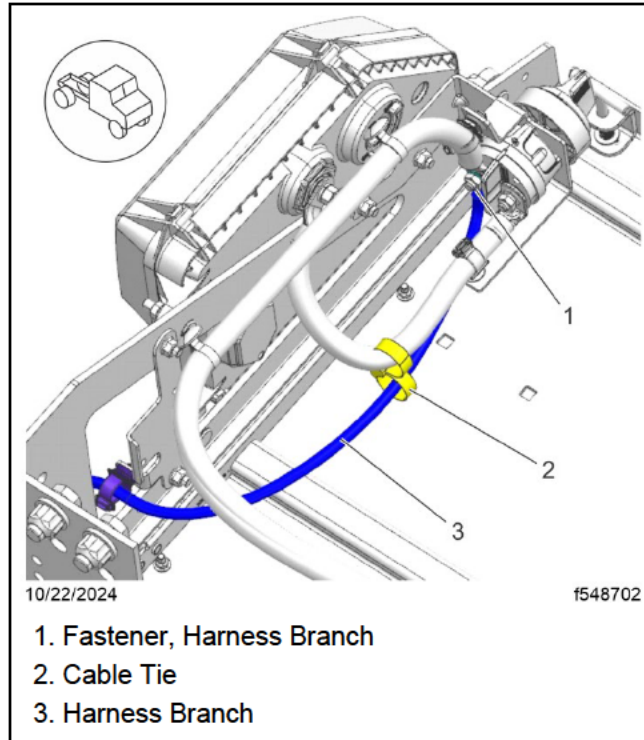

Fig. 4, Disconnecting the Harness Branch from the Manual Battery Cut-Off Switch

SF711 A

Creation Date: January 2025

Revision Date: April 2025

IMPORTANT: If a new manual cut-off switch bracket is required, follow the procedure below to install it.

- Remove the manual battery cut-off switch from the mounting bracket.
 - Remove the manual cut-off switch bracket, shown as item 2 in Fig. 5.
 - Install the new bracket (06-96803-000) and tighten the fasteners 11 lbf·ft (15 N·m).
 - Install the battery cut-off switch on the newly installed bracket.
13. Install the ALVD switch (06-97110-000), shown as item 1 Fig. 5. For detailed instructions, see drawing D66-26015-000. Tighten the fasteners 11 lbf·ft (15 N·m).

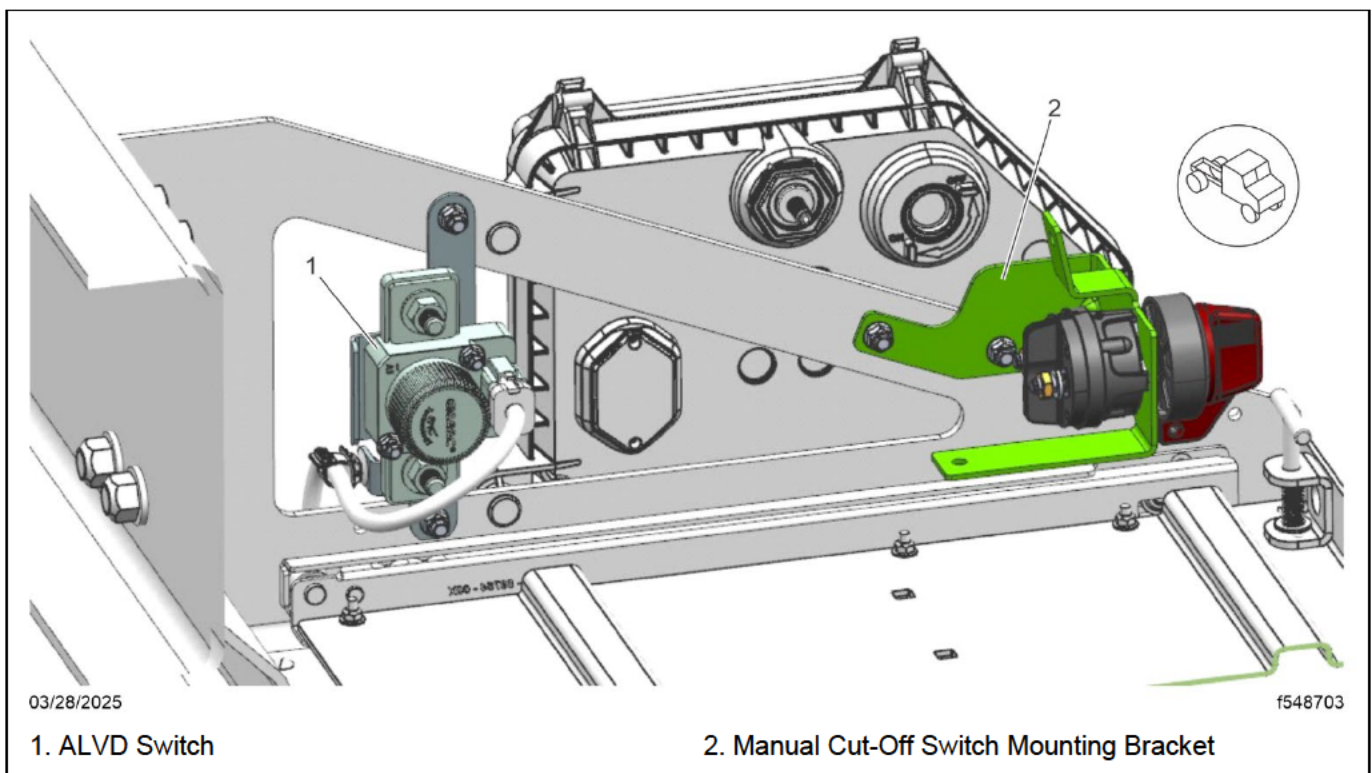

Fig. 5, ALVD Switch

SF711 A

Creation Date: January 2025

Revision Date: April 2025

14. Remove the fastener and disconnect the power cable (A66-19607-015) from the power distribution box. See **Fig. 6**. Do not disconnect the power cable from the manual battery cut-off switch. Retain the fastener for installation of the new cable in a later step.

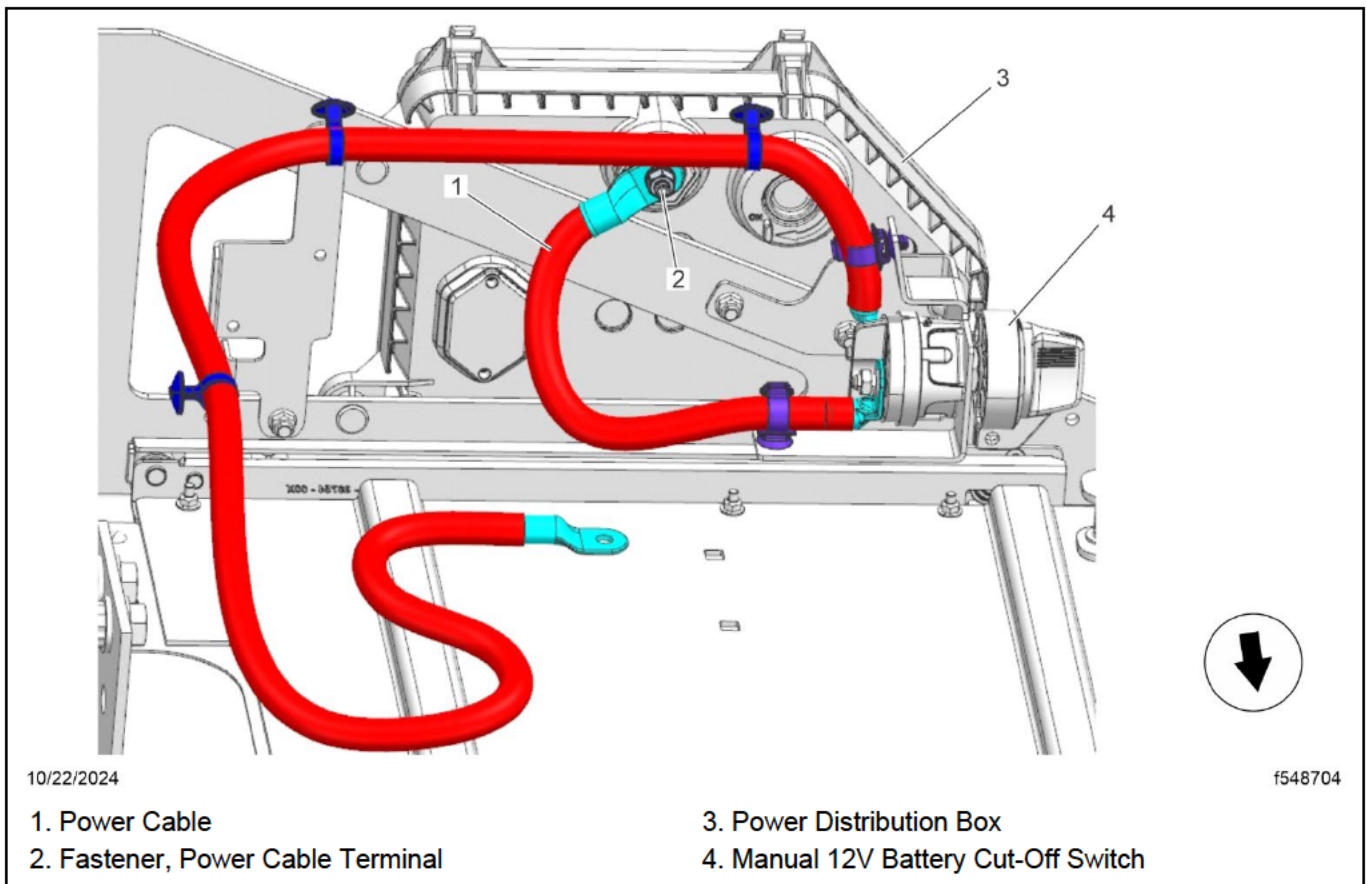

Fig. 6, Disconnecting the Power Cable from the Power Distribution Box

SF711 A

Creation Date: January 2025

Revision Date: April 2025

15. Connect the open end of the power cable (A66-19607-015) to the upper terminal on the ALVD switch, as shown in **Fig. 7**. Tighten the fastener 20 lbf-ft (27 N·m).
16. Connect the new cable (A66-19607-012) to the power distribution box, as shown in **Fig. 7**. Tighten the fastener 27 lbf-ft (37 N·m). Connect the other end of the cable to the open post on the manual battery cut-off switch. Do not tighten the fastener.

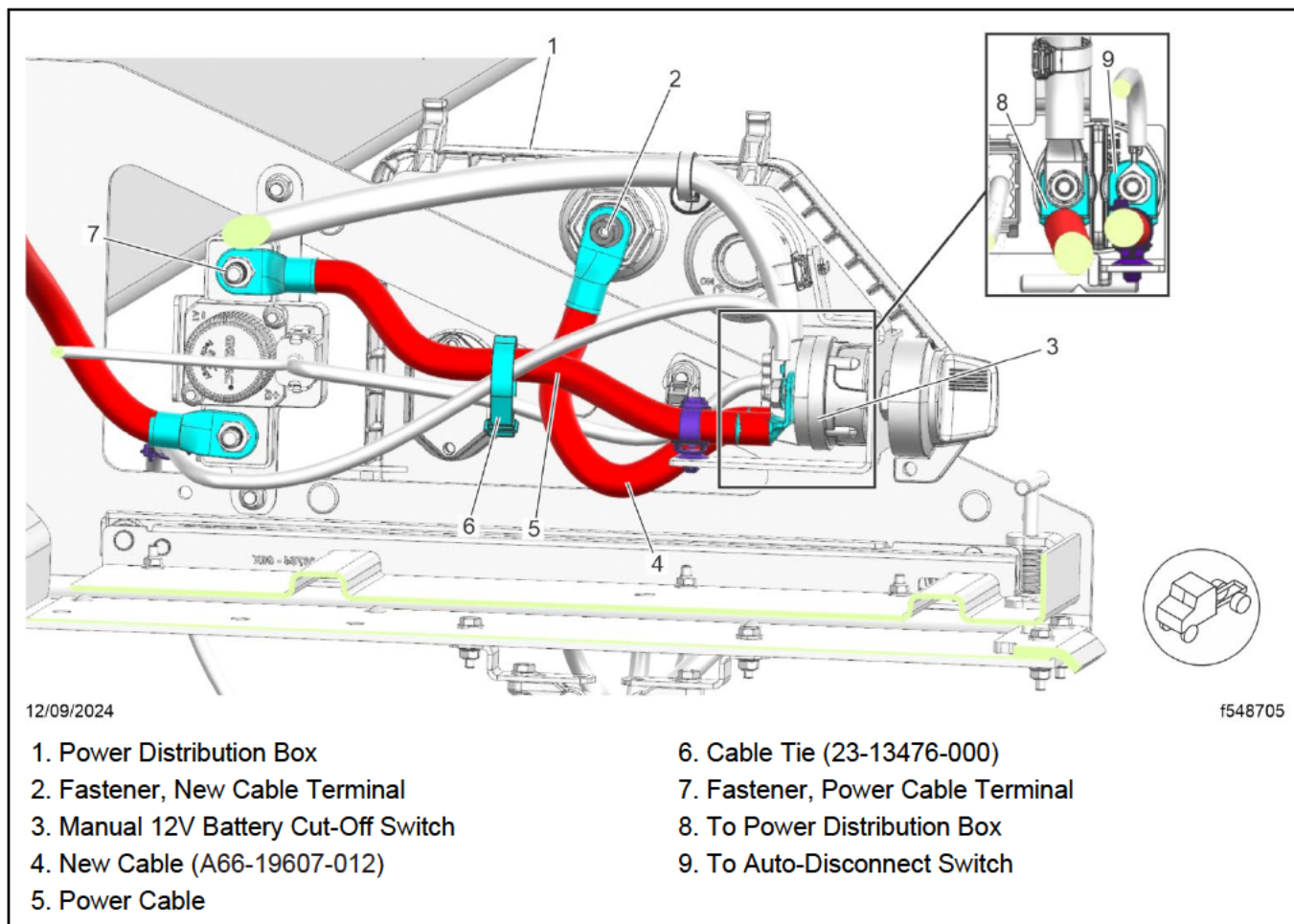

Fig. 7, Connecting the Power Cable and the New Cable

SF711 A

Creation Date: January 2025

Revision Date: April 2025

17. Connect the power cable from the VFD (A06-47195-109) to the battery cut-off switch, as shown in **Fig. 8**. Tighten the fastener 80 lbf-in (900 N-cm).
18. Use cable tie (23-14137-001), item 3 in **Fig. 8**, to clip the cable.
19. Use cable ties (23-12069-001), item 2 in **Fig. 8**, to secure the power cable.

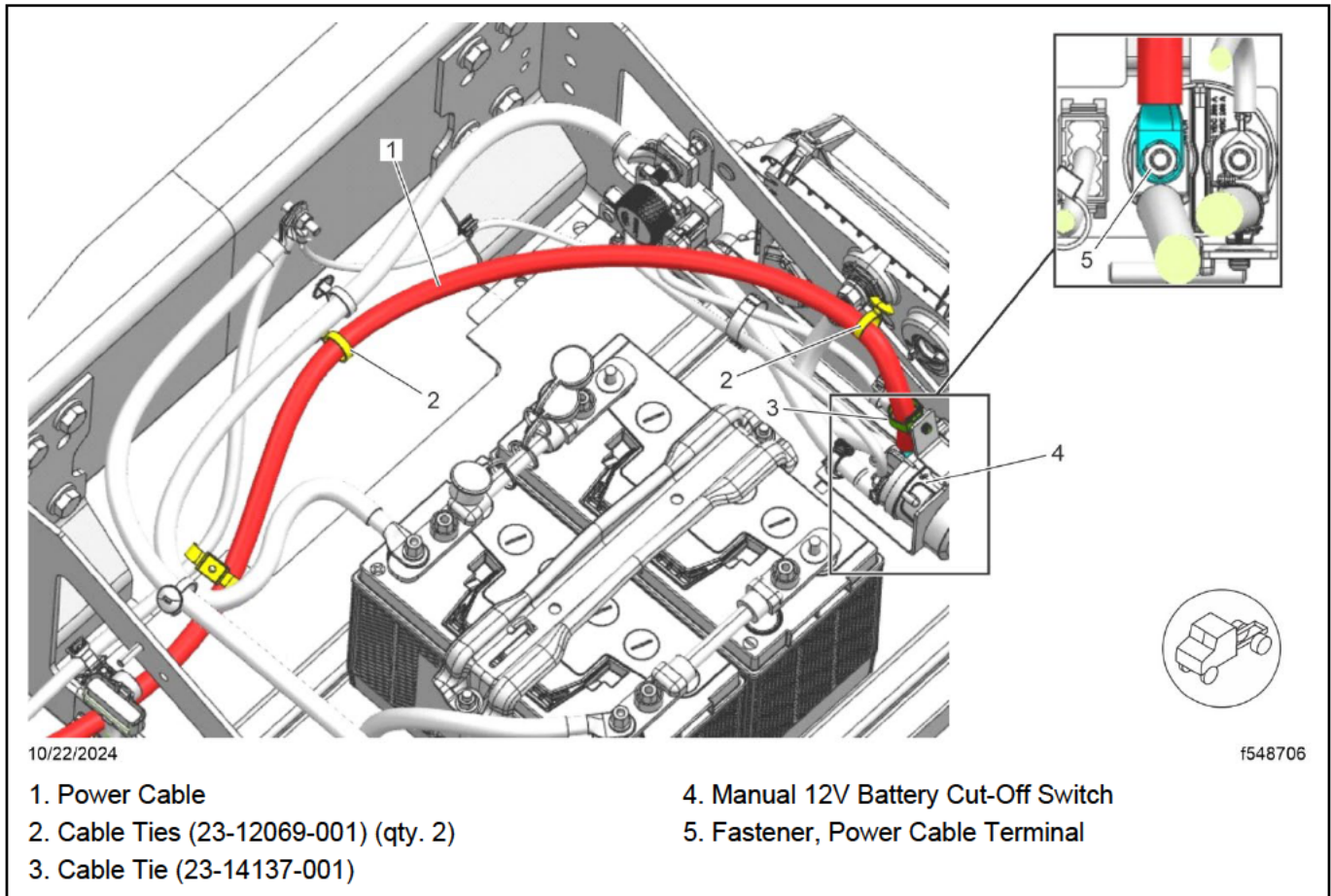

Fig. 8, Connecting the VFD Power Cable to the Battery Cut-Off Switch

20. Connect the harness (removed in step 13) to the manual battery cut-off switch at the post furthest away from the power distribution box. Tighten the fastener 80 lbf-in (900 N-cm).

SF711 A

Creation Date: January 2025

Revision Date: April 2025

21. Install the ALVD switch sub-harness. For detailed instructions, see drawing D66-32710-000. Tighten the ground stud fastener, item 1 in Fig. 9, on the frame rail 37 lbf-ft (50 N·m). Apply varnish to the ground stud.

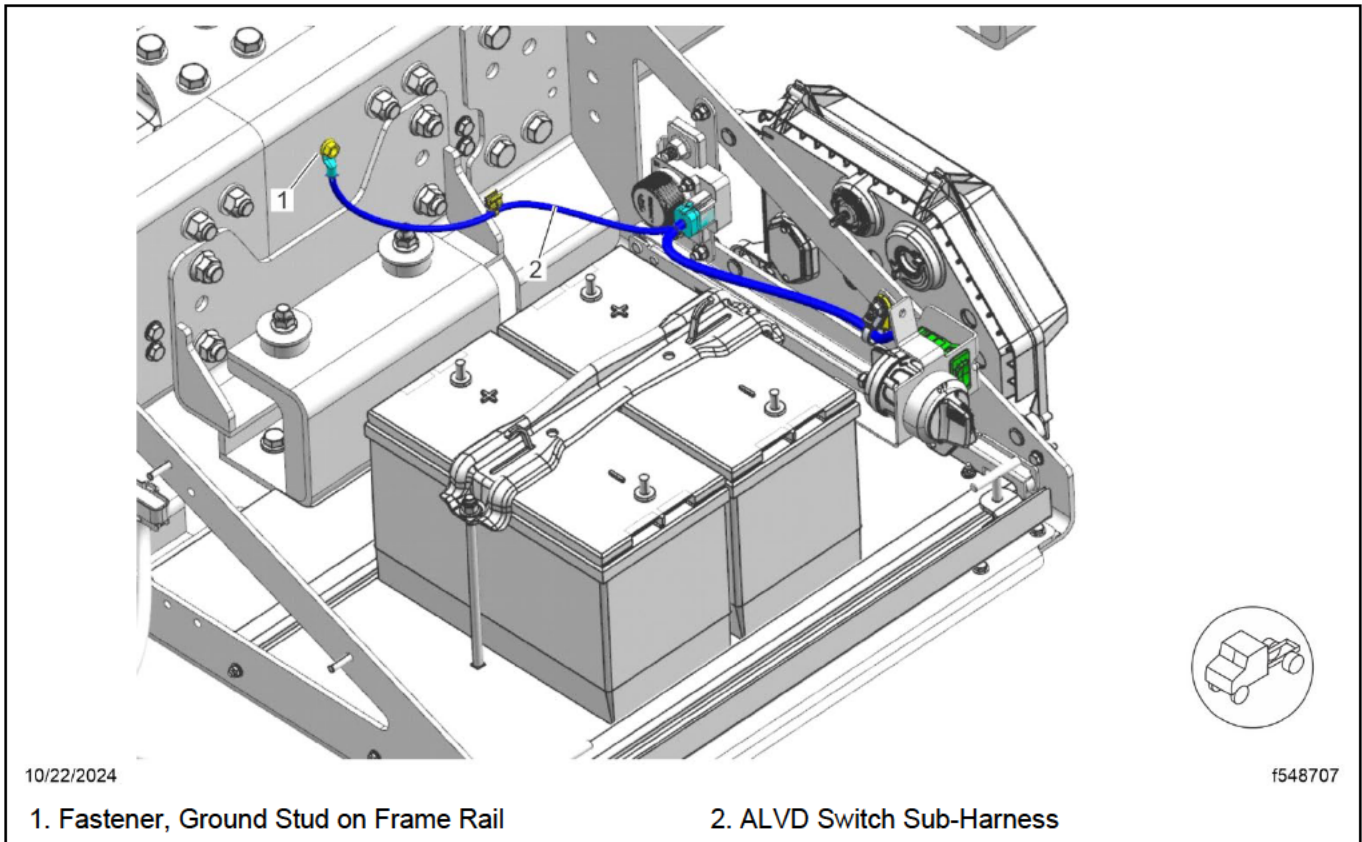

Fig. 9, Installation of the ALVD Switch Sub-Harness

22. Use cable tie (23-13476-000), item 6 in Fig. 7, to secure all three cables.

NOTE: Make sure there is enough clearance between the cables and the circuit breaker.

SF711 A

Creation Date: January 2025

Revision Date: April 2025

23. Connect the power cable (A06-34492-041) to the lower post on the ALVD switch. Tighten the fastener 20 lbf-ft (27 N·m). Clip the cable as shown in **Fig. 10** to avoid chaffing.

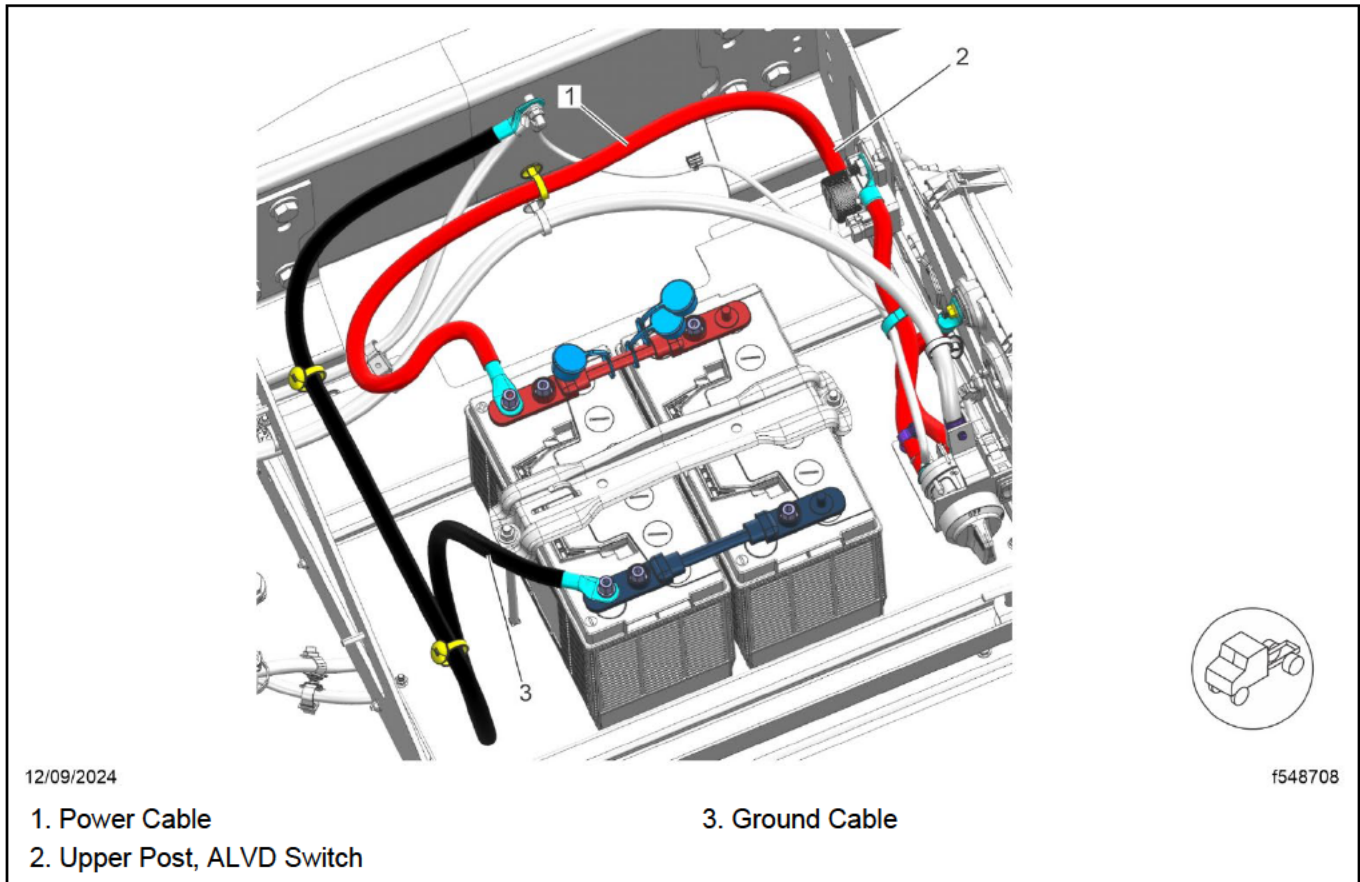

Fig. 10, Connecting the Power Cable to the ALVD Switch

24. Install the 12V batteries. Place the battery bracket in place and tighten the fasteners 24 lbf-ft (33 N·m).
25. Connect the open end of the power cable (A06-34492-041) as shown in **Fig. 10**. Tighten the fastener 21 lbf-ft (28 N·m).
26. Connect the ground cable to the battery as shown in **Fig. 10**. Tighten the fastener 21 lbf-ft (28 N·m).
27. Ensure no Malfunction Indicator Lamps (MILs) are illuminated.