

Technical Service Bulletin

Mazda North American Operations
Irvine, CA 92618-2922



Subject: RATTLING NOISE FROM LIFTGATE WHEN DRIVING	Bulletin No.: 09-020/25
	Last Issued : 04/23/2025

BULLETIN NOTES

APPLICABLE MODEL(S)/VINS

2024-2025 CX-90 with VINS lower than JM3KK*****224789 (produced before January 7, 2025)

2025 CX-70 with VINS lower than JM3KJ*****122126 (produced before January 7, 2025)

DESCRIPTION

Some customers may experience a rattling (vibration) noise from the liftgate when driving on rough roads. This noise may be caused by the gap at the attaching point of the side spoiler metal clip to the rear spoiler. To eliminate this concern, a protector has been added onto the side spoiler to prevent the vibration.

Customers having this concern should have their vehicle repaired using the following repair procedure.

REPAIR PROCEDURE

1. Verify the customer concern.

NOTE: Only repair the defective side.

The parts needed for this repair are Urethane Pad and Felt Sheet as shown below.

Attachment Area (refer to the images)	Part name	Quantity	Size (mm)	Color
For A	Urethane Pad	1	3 × 300 x 250	Black
For B	Felt Sheet	4	100 x 250	Black
Unnecessary for this repair	Urethane Pad A	4	5 × 50 x 250	Gray
	Urethane Pad B	4	10 x 50 x 250	Gray
	Butyl Tape	4	5 x 5 × 250	Black
	Felt Pad A	1	1.5 x 300 x 240	Black
	Felt Pad B	1	2.5 x 300 x240	Black
	Foam Rubber	2	5 x 300 x250	Black

CONSUMER NOTICE: The information and instructions in this bulletin are intended for use by skilled technicians. Mazda technicians utilize the proper tools/ equipment and take training to correctly and safely maintain Mazda vehicles. These instructions should not be performed by "do-it-yourselfers." Customers should not assume this bulletin applies to their vehicle or that their vehicle will develop the described concern. To determine if the information applies, customers should contact their nearest authorized Mazda dealership. Mazda North American Operations reserves the right to alter the specifications and contents of this bulletin without obligation or advance notice. All rights reserved. No part of this bulletin may be reproduced in any form or by any means, electronic or mechanical--including photocopying and recording and the use of any kind of information storage and retrieval system ---without permission in writing.

2. Remove the rear side spoiler.

NOTE: Refer to "Side Spoiler Removal Note" in REAR SPOILER REMOVAL/INSTALLATION.

- CX-90 (REAR SPOILER REMOVAL/INSTALLATION)
- CX-70 (REAR SPOILER REMOVAL/INSTALLATION)

3. Attach the High-Density Urethane Pad to the rear side spoiler.

a. Cut the High-Density Urethane Pad to make a 50 x 5 mm pad.

b. Remove grease from the pad attachment area and then attach the pad to (A) indicated in the image

NOTE: The pad must be attached on the flat surface, right next to the curved surface.

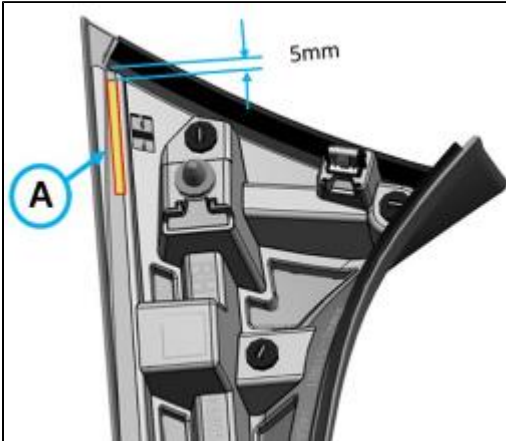

4. Attach the felt sheet to the rear spoiler.

a. Cut the felt sheet into 2 pieces, each measuring 20 x 5 mm.

b. Remove the grease from the sheet attachment areas and then attach the sheets to (B) indicated in the image.

NOTE: The sheets must be attached on the flat surface, right next to the curved surface.

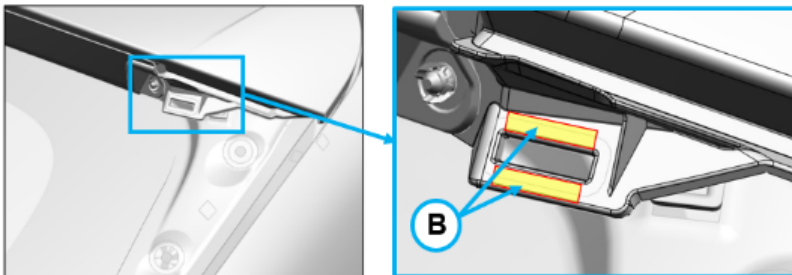

5. Install in the reverse order of removal.

6. Verify the repair.

CONSUMER NOTICE: The information and instructions in this bulletin are intended for use by skilled technicians. Mazda technicians utilize the proper tools/ equipment and take training to correctly and safely maintain Mazda vehicles. These instructions should not be performed by "do-it-yourselfers." Customers should not assume this bulletin applies to their vehicle or that their vehicle will develop the described concern. To determine if the information applies, customers should contact their nearest authorized Mazda dealership. Mazda North American Operations reserves the right to alter the specifications and contents of this bulletin without obligation or advance notice. All rights reserved. No part of this bulletin may be reproduced in any form or by any means, electronic or mechanical---including photocopying and recording and the use of any kind of information storage and retrieval system ---without permission in writing.

PARTS INFORMATION

Parts Number	Description	Qty.	Notes
K001-W0-225	Interior Noise Repair Kit	1	NOTE: DO NOT throw the Noise Parts Kit away. It is considered a shop supply that repairs multiple vehicles for multiple issues and the cost is included in the Labor Time.

WARRANTY INFORMATION**NOTE:**

- This warranty information applies only to verified customer complaints on vehicles eligible for warranty repair.
- This repair will be covered under Mazda's New Vehicle Limited Warranty term.
- Additional diagnostic time cannot be claimed for this repair.

Warranty Type	A
Symptom Code	82
Damage Code	97
Part Number Main Cause	7777-SP-Y82
Quantity	0
Operation Number / Labor Hours:	XXWZ6ARX / 0.3 Hrs. (One side) XXWZ6BRX / 0.4 Hrs (Both sides)

CONSUMER NOTICE: The information and instructions in this bulletin are intended for use by skilled technicians. Mazda technicians utilize the proper tools/ equipment and take training to correctly and safely maintain Mazda vehicles. These instructions should not be performed by "do-it-yourselfers." Customers should not assume this bulletin applies to their vehicle or that their vehicle will develop the described concern. To determine if the information applies, customers should contact their nearest authorized Mazda dealership. Mazda North American Operations reserves the right to alter the specifications and contents of this bulletin without obligation or advance notice. All rights reserved. No part of this bulletin may be reproduced in any form or by any means, electronic or mechanical---including photocopying and recording and the use of any kind of information storage and retrieval system ---without permission in writing.