

Vermeer MV Solutions, Inc.

Trenchless
 Piedmont, South Carolina 29673 USA

FIELD CAMPAIGN KIT #: VMV000064 Rev. 1

DATE: 2025 April 25

For Dealer Reference: Service Bulletin #: SMV2024-014 Rev. 1

Remote Grease Line Installation and Manual Update Kit

CAMPAIGN TYPE:

Mandatory – Product Safety

CAMPAIGN CATEGORY:

Kit and Bulletin

MACHINE/ ATTACHMENT MODEL(S):	SERIAL NUMBERS:		Kit version
	Included	Excluded	
HTV373PTO	See attached listing on page 20 of this kit instruction for specific truck VIN, and MV Solution model and VIN.	None	VMV01
HTV873PTO	See attached listing on page 20 – 21 of this kit instruction for specific truck VIN, and MV Solution model and VIN.		
JTV873PTO	See attached listing on page 21 of this kit instruction for specific truck VIN, and MV Solution model and VIN		

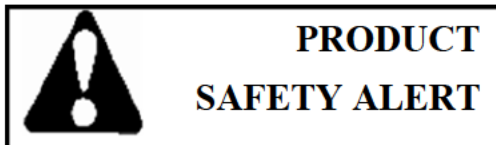

Purpose:

Revision 1:

- The kit instructions are being revised to update the size of hole that needs to be drilled from 7/16 inch to 17/64 inch.

MAINTENANCE PERSONNEL MUST WORK UNDER LIFTED LOAD. Some machines were not equipped with a debris tank support device. Maintenance personnel must work under raised debris tank in order to grease debris tank lift mechanism. DEATH OR SERIOUS INJURY. If the debris tank were to lower unexpectedly while greasing the debris tank lift mechanism, the maintenance person performing that work could be crushed.

VMV000064 has been created to provide the necessary parts and instructions to add remote grease lines and updated operator's manual. The remote grease system eliminates the need to work under the lifted load. If equipped, existing debris tank support devices are no longer required for greasing the debris tank lift mechanism. This kit must be installed as soon as possible.

Special Tools and Conditions:

- None



WARNING: Use the following shutdown procedure before attempting to do any of the work described in this Kit.



WARNING: Failure to use shutdown procedure can result in unexpected hazard(s). Death or serious injury could result due to entanglement, crushing, cutting, or other hazardous contact. Follow Shutdown Procedure after operating, before performing any service or maintenance, and before transporting.

Shutdown Procedure:

1. Reduce engine speed to idle.
2. Wait 1 minute to shut off engine when shutting down after operating at full power.
3. Shut off engine and remove key.

For your safety and the safety of others, use shutdown procedure before servicing, cleaning, unplugging, or inspecting the machine.

If working on the machine, follow Lockout Procedure, if necessary.

Vary this procedure if instructed within this kit or if emergency requires it.

PROCEDURE:

- ⇒ Unless indicated, new parts from kit have callouts with numbers. Callouts with letters indicate existing parts or general items.
- ⇒ Components in this kit have been hidden to help identify parts that are being removed or added.



WARNING: Pressurized fluid can penetrate body tissue and result in death or serious injury. Leaks can be invisible. Keep away from any suspected leak. Relieve pressure in the hydraulic system before searching for leaks, disconnecting hoses, or performing any other work on the system. If you must pressurize the system to find a suspected leak, use an object such as a piece of wood or cardboard rather than your hands. When loosening a fitting where some residual pressure may exist, slowly loosen the fitting until oil begins to leak. Wait for leaking to stop before disconnecting the fitting. Fluid injected under the skin must be removed immediately by a surgeon familiar with this type of injury.

Tank Hooks:

Remove and discard the tank hooks.

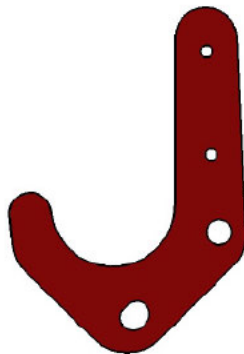
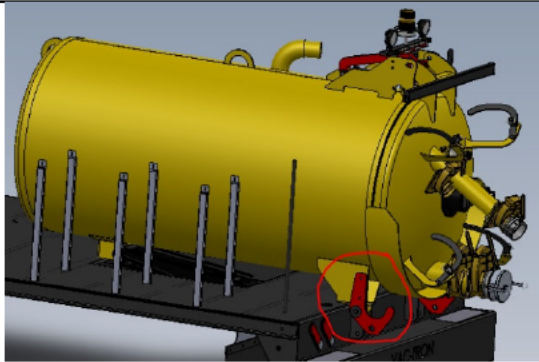

F375-4149

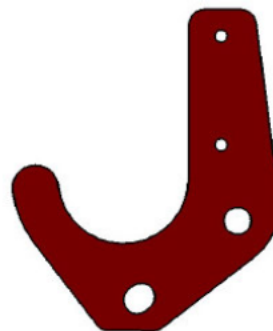

F375-4153

Mark Holes for Mounting Plate Installation:

1. Measure or hold bracket in place and mark two hole locations **(1)**.

Holes are NOT centered on the C-channel. They are closer to open side of C-channel, ensuring that hardware will fit on inside of channel.

2. Drill holes **(2)** with clearance for 3/8" bolt.

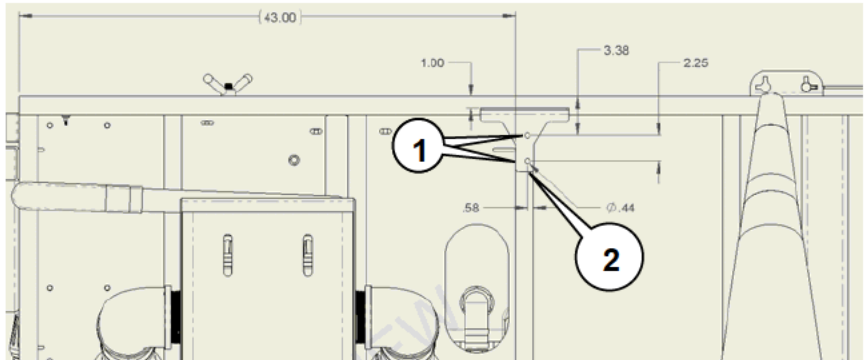

Install Fittings Into Mounting Plate:

3. Install six panel mount fittings **(3)** onto mounting plate (P/N 135009682).
4. Install six grease fittings **(4)** (P/N 135009693) onto mounting plate (P/N 135008453).

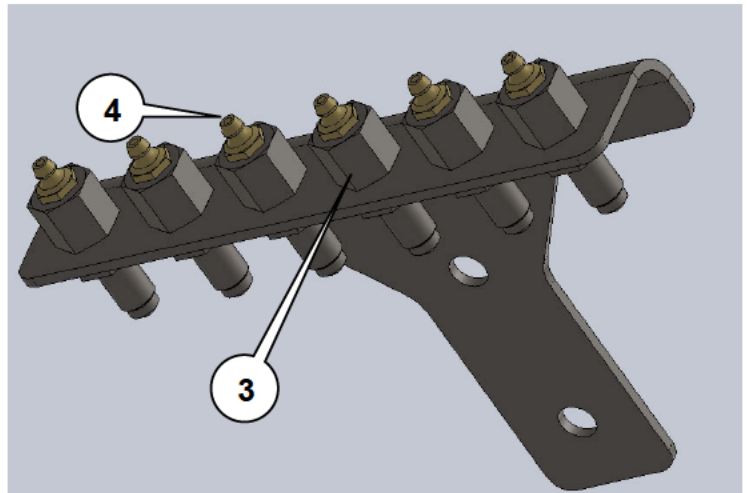

Install grease fitting mounting plate on truck:

5. Install grease fitting mounting plate (5) with fittings on truck.

Use the hardware below:

- P-1474 Lock Nut, 3/8-16, Nylock (qty 2)
- P-5648 Washer, 3/8" (qty 2)
- 37C150HCS5Z Hex Head Cap Screw, 3/8-16x1.5" (qty 2)
- 135009884 Washer, Leveling, 3/8" (qty 2)

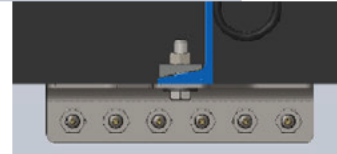
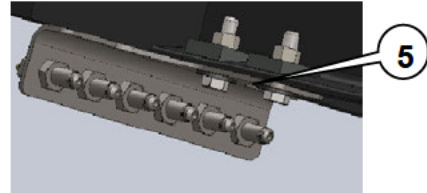
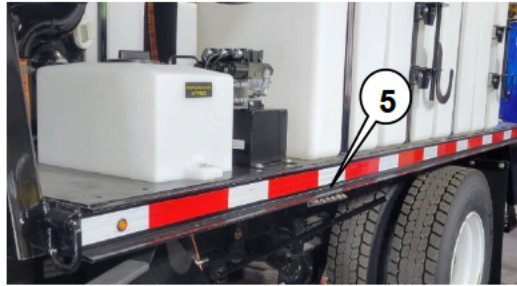

Raising the Debris Tank (Without Boom)

For PTOs Without a Boom: Raising Debris Tank To Upright Position

6. Raise the debris tank **(6)** via the 6-button pendant **(7)** to its most raised position and leave in that position.

If this work is to be done indoors, be watchful of height requirements. With debris tank raised, maximum height without a boom is approximately 13-1/2 feet.

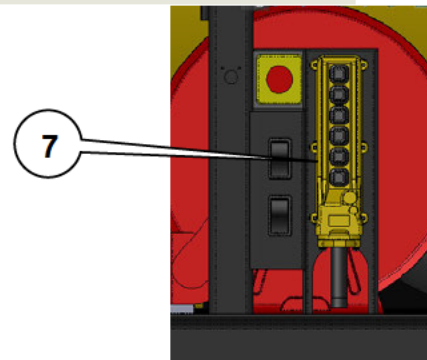
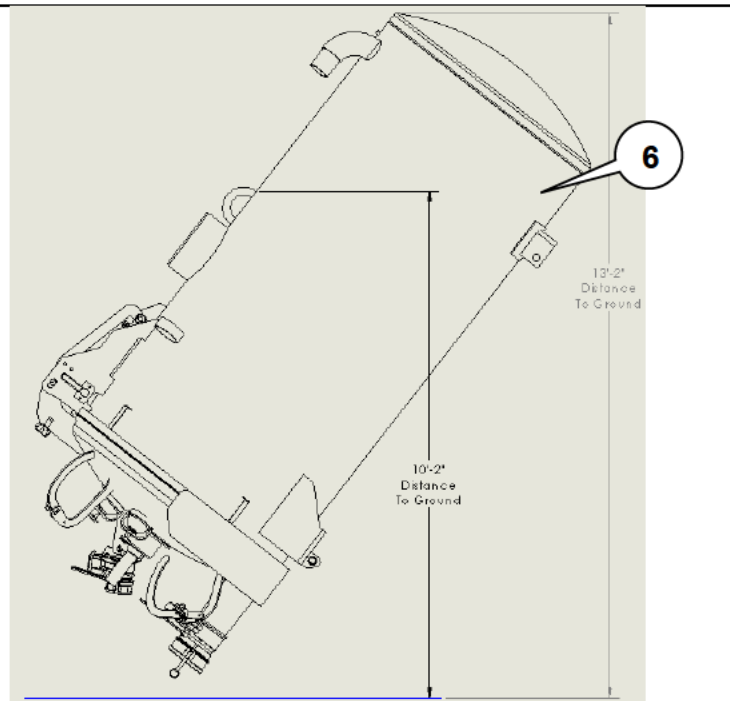

Raising the debris tank (with boom)

For PTOs With a Boom: Raising Debris Tank To Upright Position

If this work is to be done indoors, be watchful of height requirements. With debris tank raised, maximum height without a boom is approximately 13-1/2 feet.

7. Raise the boom (8) and rotate it approximately 180 degrees so that it points to the back of the debris tank.
8. Extend the boom (9) to its maximum length.
9. Raise the boom (10) to the maximum height.
10. Raise the debris tank (11) via the 6-button pendant to its **most raised position** and leave in that position.

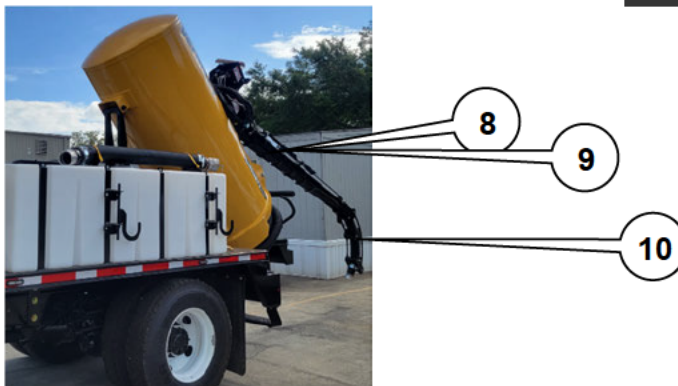
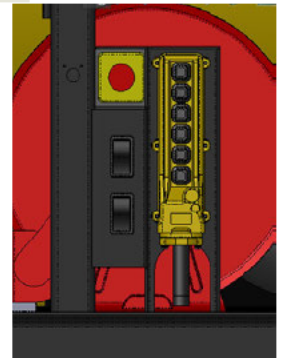
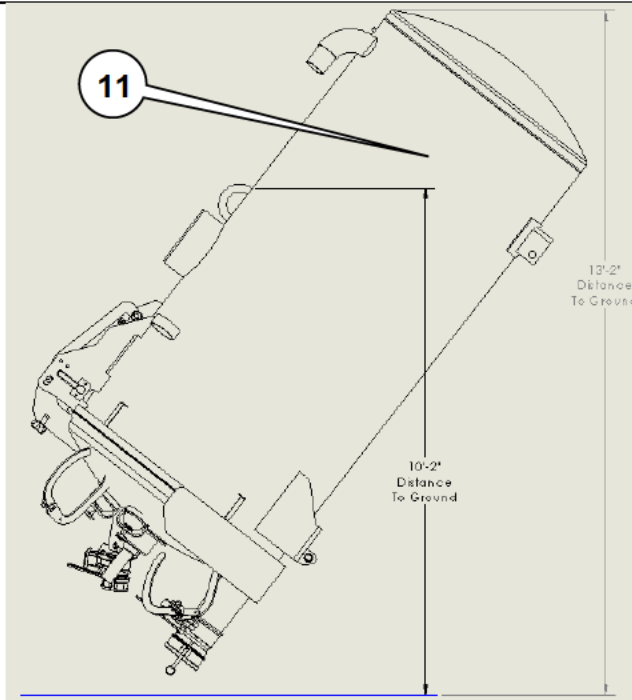

Secure the debris tank (PTOs with or without boom)

For PTOs With or without a Boom: Secure Debris Tank To Upright Position

Either an over-head crane will be needed or a stack of 4x4s will be needed to secure the debris tank in the upright position.

With the debris tank raised to its maximum height (see previous pages), the tank must have a redundant form of holding the tank up.

This can be accomplished, in one of two ways:

- Support the debris tank by stacking 4x4 blocks of wood.
- Use an overhead crane to secure the debris tank in place.

11. Secure with 4 x 4's (method 1)

With the debris tank raised to its highest position, securely stack 4"x4"x4.5' lengths of wood under the flat portion of the first knuckle of the scissors. The lengths of wood must be long enough to safely and securely span the scissor opening.

12. Secure With An Overhead Crane (method 2)

With the debris tank raised to its highest position, use the debris tank lifting ring and the overhead crane to secure debris tank in place.



Secure Debris Tank In Upright Position
By Stacking 4x4s

Secure With An Overhead Crane

With the debris tank raised to its highest position, use the debris tank lifting ring and the overhead crane to secure debris tank in place.

Remove (4x) existing grease fittings

13. Leave one grease fitting (12) in the top of scissor.
14. Remove two grease fittings (13) from the center scissor connection (one on the pivot and one below it.)
15. Remove two of the three grease fittings (14) (leave the center grease fitting in place) from the base of the scissor that is hard mounted to the platform.
16. Dispose of removed grease fittings.

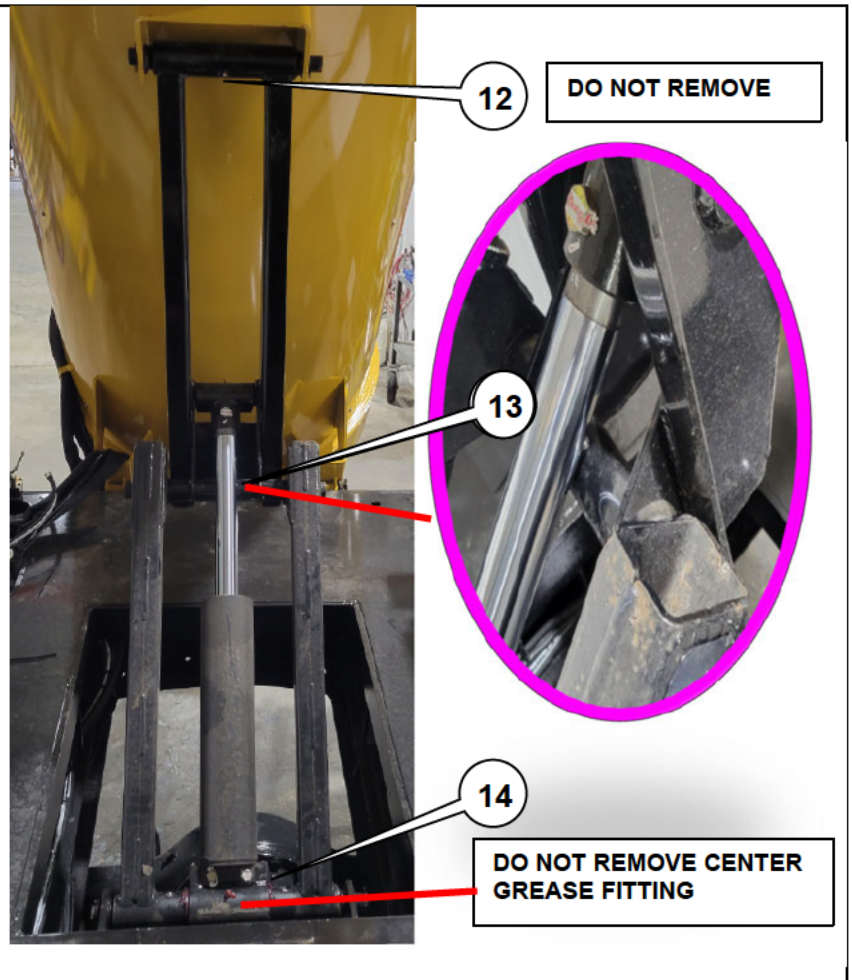

Drill (2x) new 17/64 inch holes into debris tank scissor

- (1X) on top of scissor
- (1X) on base of scissor

See next step for specific location of new holes.

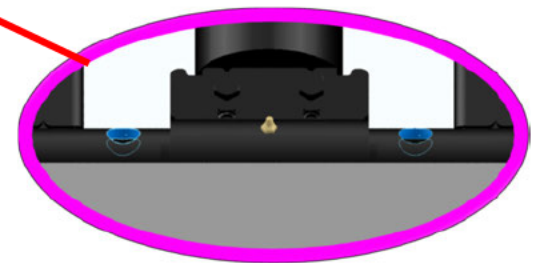
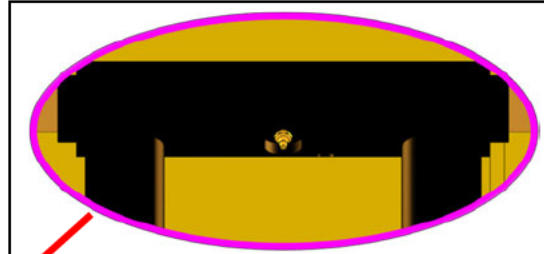

Drill (1x) new 17/64 inch hole into top of debris tank scissor

17. Hole (15) is to be made with a 17/64 inch drill to a depth of 1/4 inch

18. Hole (15) is to be 2 inches from support, toward the driver's side of the truck as shown in the right view.

19. Hole (15) is to be centered on the support as shown in the lower view.

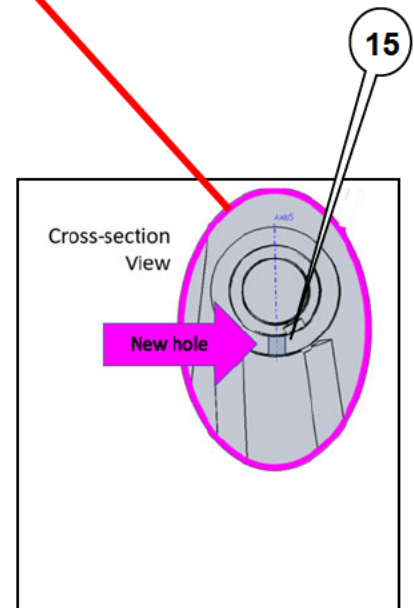
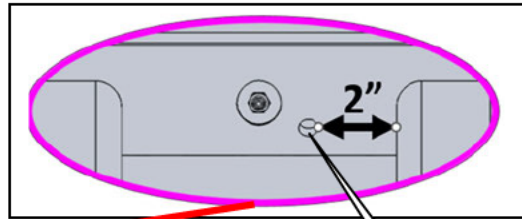

Drill (1x) new 17/64 inch hole into bottom of debris tank scissor

- 20. Hole (16) is to be made with a 17/64 inch drill to a depth of 1/4 inch.
- 21. Hole(16) is to be 180 degrees from the remaining grease fitting. This can be drilled from underneath the platform.)

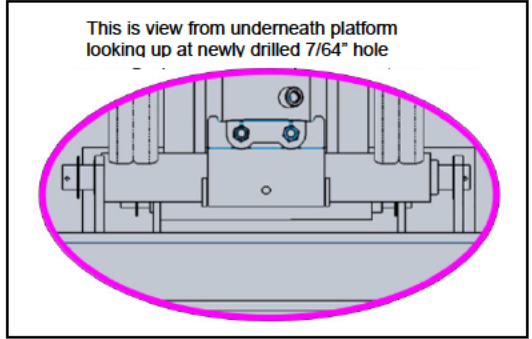

64"

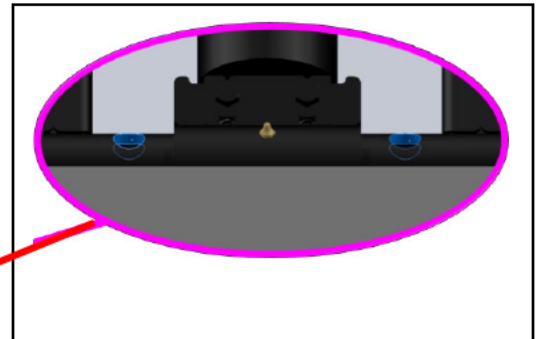

Cross-section view

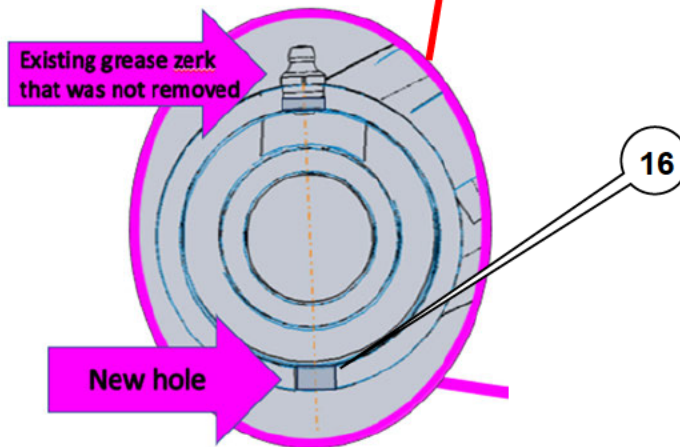

Helical insert preparation and installation on the scissor

Follow manufacturing instructions shown for preparing (6x) holes for helical inserts and insertion of (6x) helical inserts.

Use a 17/64 inch drill included with the kit.

Mark drill at 5/16 inch depth and only drill to that depth.

22. Drill out damaged threads (17).

23. Tap hole (18) for new threads with the tap provided.

24. Install new Perma-coil insert (19). (Prewinding tool shown is used for fine thread applications only).

25. Remove tang from insert (20). The thread is now permanently repaired.

These images and instructions are from threadkits.com

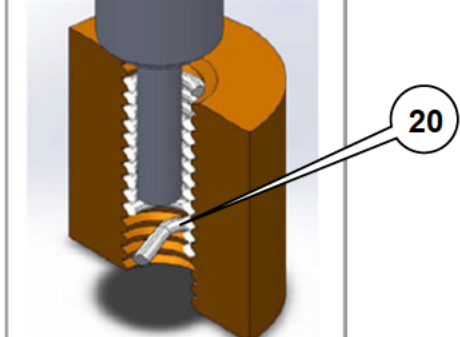
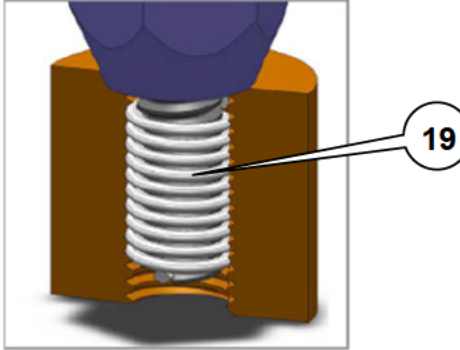
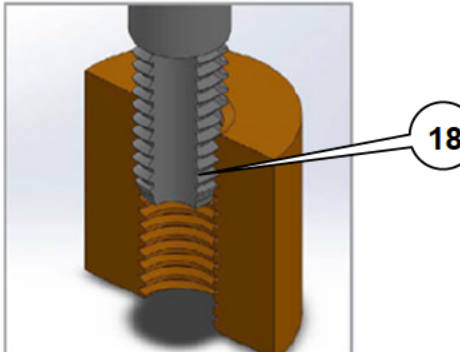
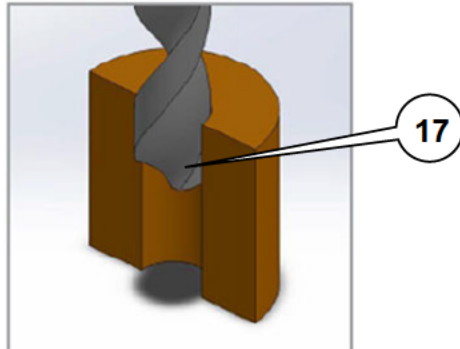

Fitting installation on the scissor

26. Install fittings **(21)** into the newly drilled hole in upper scissor location.

- 135009705 Fitting, Grease Adapter, 1/4-28 SAE-LT Taper Thread
- 135009716 Fitting, Straight, 7/16-20 Male JIC x 1/8-27 Male NPTF

27. Install fittings **(22)** into the center scissor location.

- 135009705 Fitting, Grease Adapter, 1/4-28 SAE-LT Taper Thread
- 135500244 Fitting, Swivel Elbow, 7/16-20 JIC-F, 7/16-20 JIC-M
- 135500244 Fitting, Swivel Elbow, 7/16-20 JIC-F, 7/16-20 JIC-M

28. Install fittings **(23)** into the center scissor location (on underside).

- 135009705 Fitting, Grease Adapter, 1/4-28 SAE-LT Taper Thread
- 135009707 Fitting, Elbow, 7/16-20 Male JIC x 18-27 Male NPTF

29. Install fittings **(24)** into the newly drilled hole in lower scissor location (3 places on lower scissor).

- 135009705 Fitting, Grease Adapter, 1/4-28 SAE-LT Taper Thread
- 135009707 Fitting, Elbow, 7/16-20 Male JIC x 18-27 Male NPTF

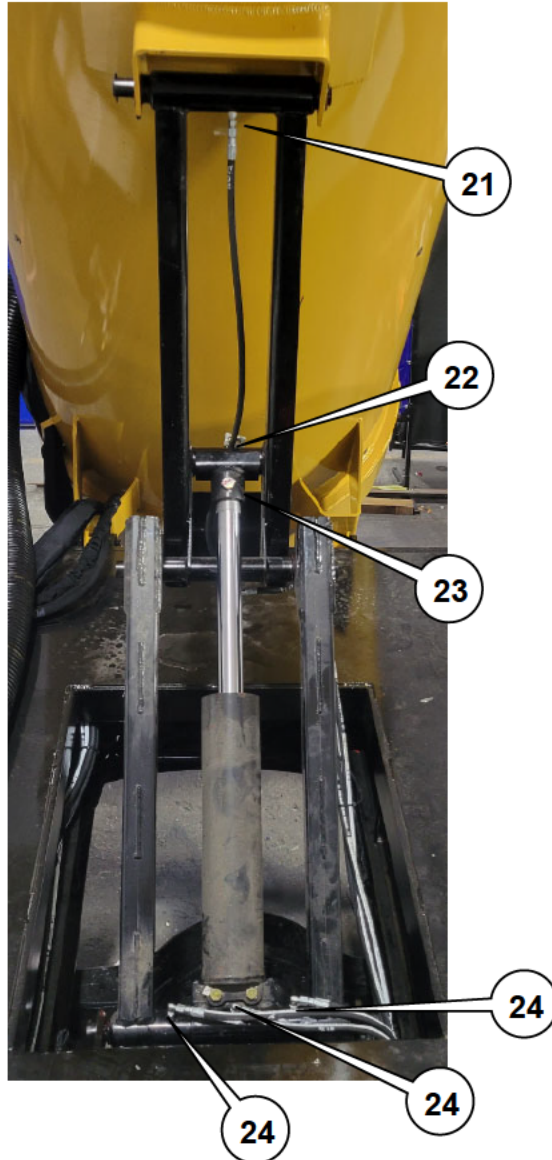

Hose installation on the scissor

SEE HOSE ROUTING DIAGRAM

30. Install hose **(25)** into the upper scissor location.

- 135009740 Hose Assembly (color-coded red)

31. Install hose **(26)** into the center scissor location.

- 135009739 Hose Assembly (color-coded purple)

32. Install hose **(27)** into the center scissor location (on underside).

- 135009738 Hose Assembly (color-coded orange)

33. Install hose **(28)** into the lower scissor location.

- 135009736 Hose Assembly (color-coded blue)

34. Install hose **(29)** into the lower scissor location.

- 135009730 Hose Assembly (color-coded green)

35. Install hose **(30)** into the lower scissor location.

- 135009725 Hose Assembly (color-coded brown)

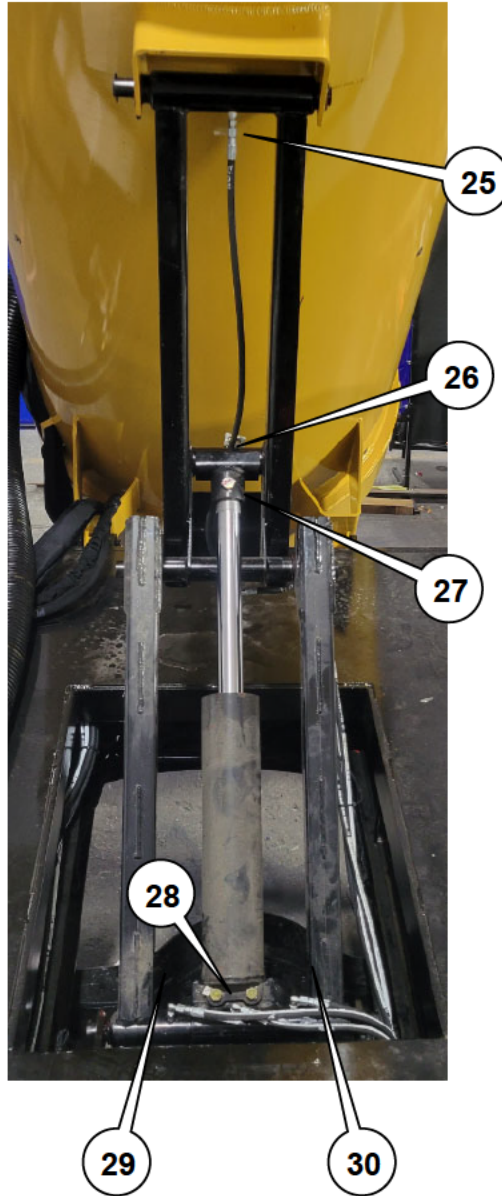

Hose routing diagram on the scissor

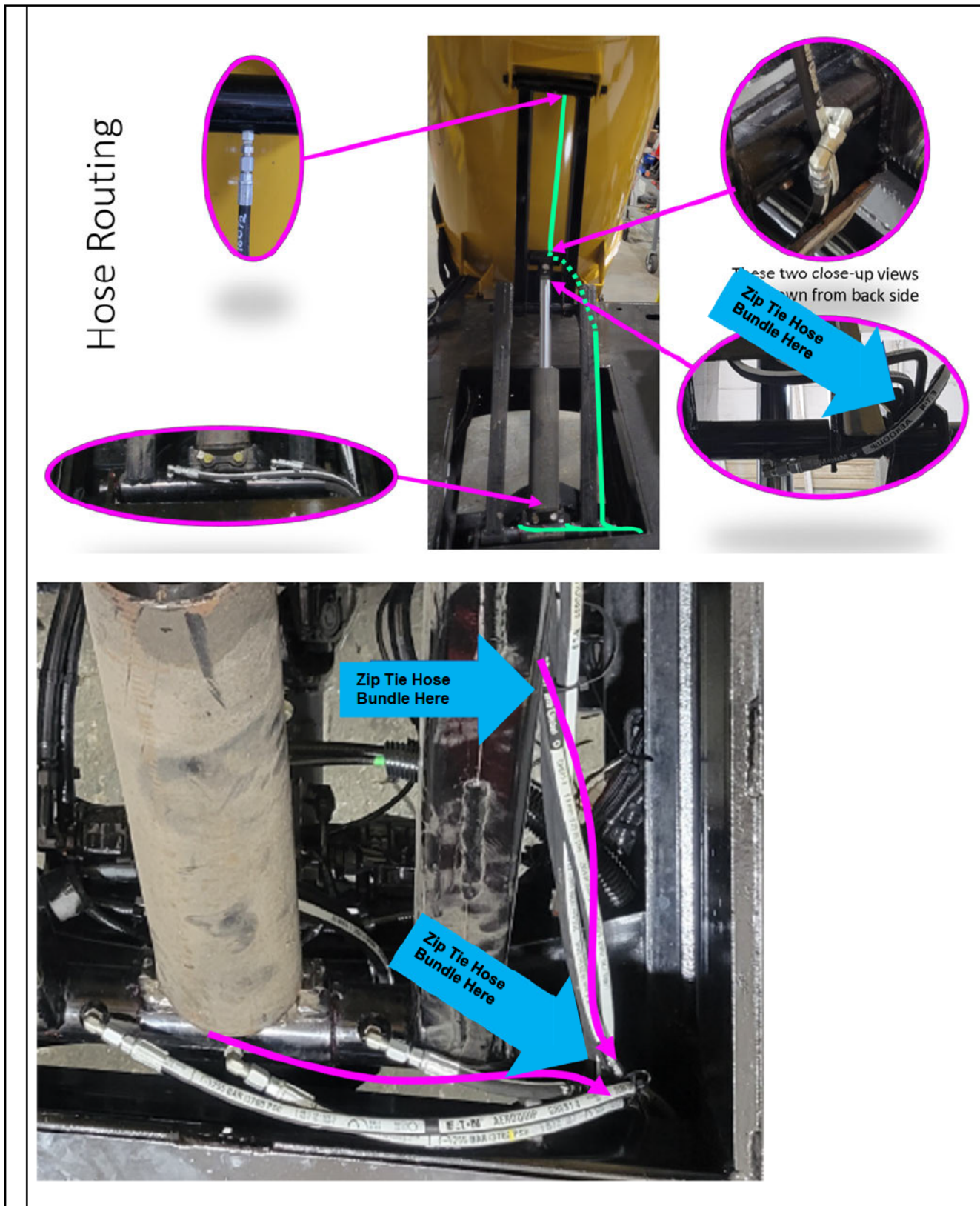

Hose routing diagram (continued)

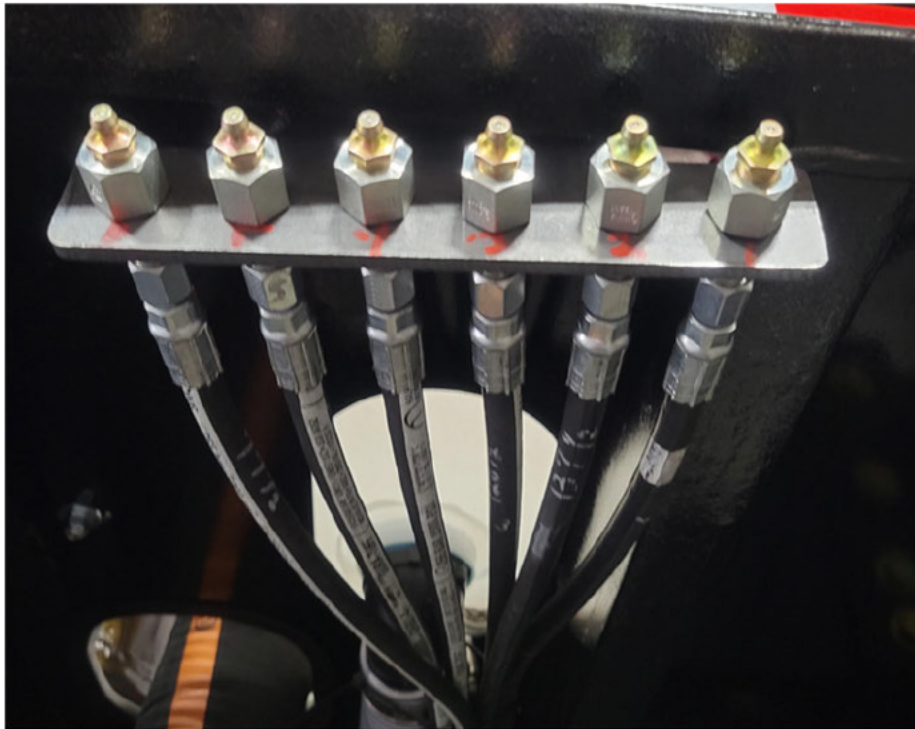
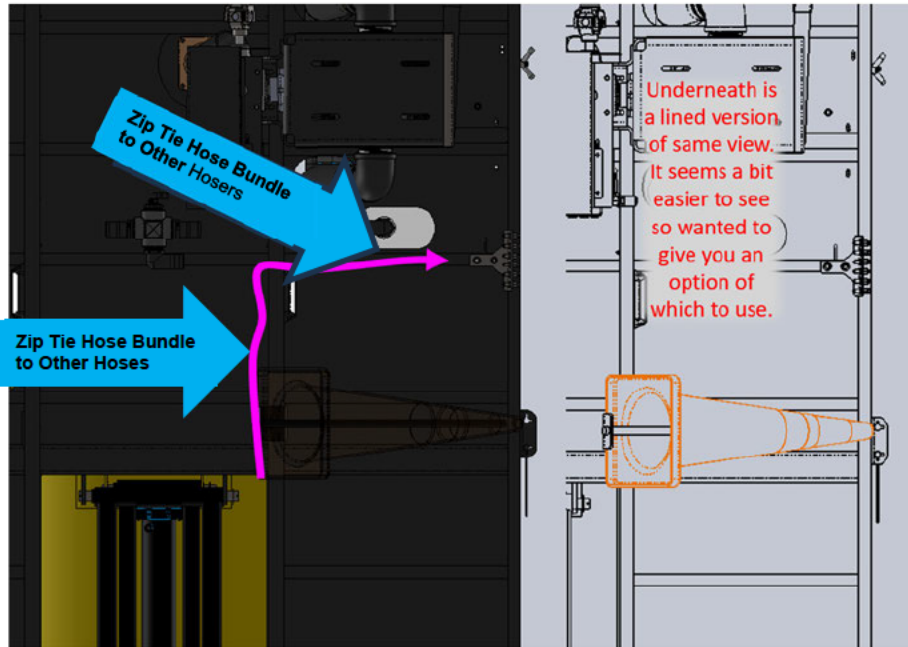

The order in which they are installed in this bracket is of no consequence.

Apply grease per table below after new grease line installation is complete.

Section 105: Specifications

Lubricants

Engine oil	Capacity	Specification/notes
Refer to truck manual	Refer to truck manual	Refer to truck manual
Blower	Capacity	Specification/notes
Grease: Lithium Complex base, NLGI Grade 2 EP, contain rust inhibitors and suitable for blower discharge temp. to 350°F (177°C)	As needed	Fittings and grease applicator nozzle must be clean before applying grease. Replace all missing fittings. Do not mix different types of grease. Do not over grease.
Oil: SAE 30W (non-detergent)	To center of sight gauge	Do not overfill gearbox. Too much oil may cause excessive heating of the gears and may damage the unit.
Hydraulic Fluid	Capacity	Specification/notes
BIOHYDRAN AW - ISO32	Fill tank allowing 1/2 in (13 mm) space at top of tank (with all cylinders retracted)	This hydraulic fluid is environmentally sensitive, and used because the back door hoses are inside the debris tank and may come in contact with the collected material. Do not allow contaminates into the system while servicing. Filter all fluid through a 10-micron filter before adding.

Water pump	Capacity	Specification/notes
Oil: SAE 30W (non-detergent)	To center of sight gauge	Do not allow contaminates into the system while servicing. Filter all fluid through a 10-micron filter before adding.
General greasing	Capacity	Specification/notes
Grease: marine grease	As needed	Fittings and grease applicator nozzle must be clean before applying grease. Replace all missing fittings. Do not mix different types of grease. Do not over grease.

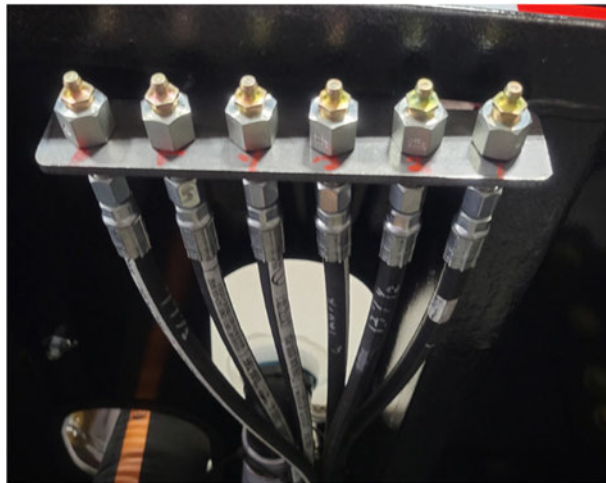

Figure 1

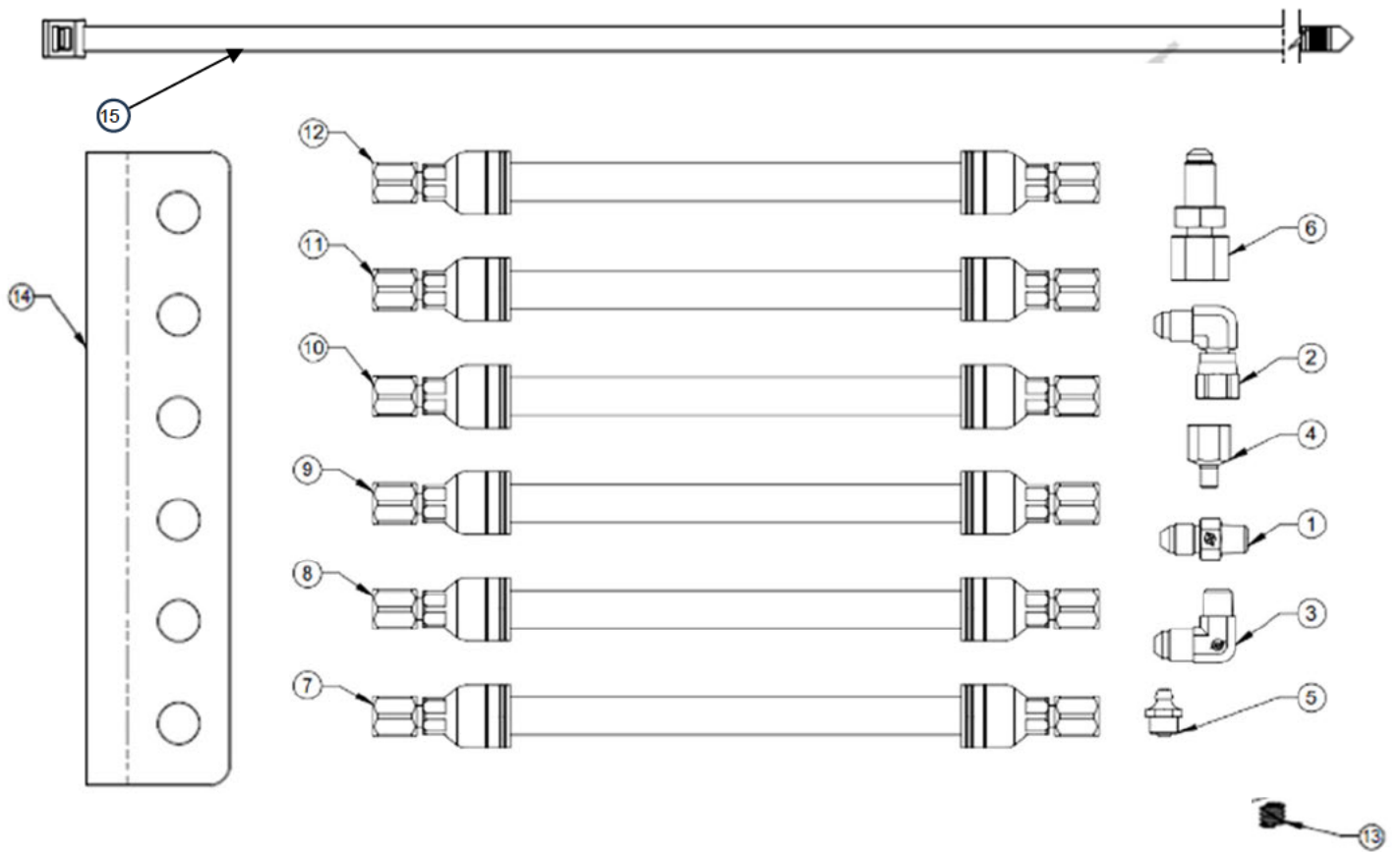

FIGURE 1 Parts List			
REF. NO.	PART NO.	DESCRIPTION	VMV00006401 QTY.
1	135009716	Fitting, Straight, 7/16-20 Male JIC x 18-27 Male NPTF	1
2	135500244	Fitting, Swivel Elbow, 7/16-20 JIC-F x 7/16-20 JIC-M	1
3	135009707	Fitting, Elbow, 7/16-20 Male JIC x 18-27 Male NPTF	5
4	135009705	Fitting, Grease Adapter, 1/4-28 SAE-LT Taper Thread x 1/8" NPTF	6
5	135009693	Grease Fitting 1/8-27 NPT	6
6	135009682	Fitting, Panel Mount, 1/8-27 NPTF x 7/16-20 UNF	6
7	135009740	Hose Asm, -4 Hose, -4 SAE 37DegFemaleSwivel, 160.5"	1
8	135009739	Hose Asm, -4 Hose, -4 SAE 37DegFemaleSwivel, 133"	1
9	135009738	Hose Asm, -4 Hose, -4 SAE 37DegFemaleSwivel, 125"	1
10	135009736	Hose Asm, -4 Hose, -4 SAE 37DegFemaleSwivel, 87"	1
11	135009730	Hose Asm, -4 Hose, -4 SAE 37DegFemaleSwivel, 82"	1
12	135009725	Hose Asm, -4 Hose, -4 SAE 37DegFemaleSwivel, 77"	1
13	135009768	Helical Insert, 1/4-28 x 1/4" Long, Stainless	6
14	135008453	Bracket, Grease Line Mount	1
15	135009909	Cable Tie, 14.5" Long, 120 lb, Black, Nylon 66	5
		VMV010064 includes all items in Figure 1 Parts List.	

See Figure 1 for breakdown of Item 1

UNIT OWNER COPY: Insert in Parts Manual for future reference.

Figure 2

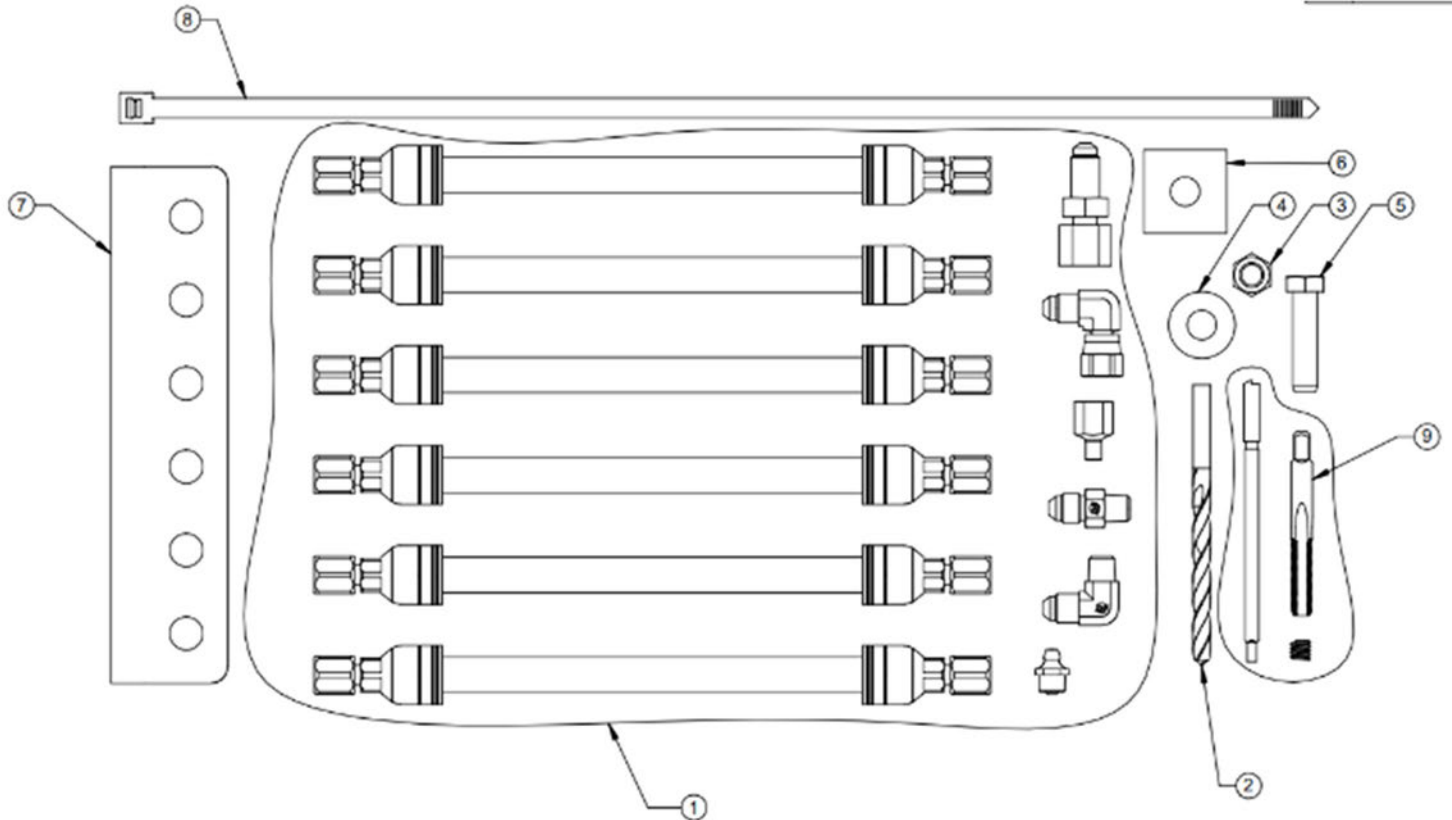

FIGURE 2 Parts List

REF. NO.	PART NO.	DESCRIPTION	VMV0006401 QTY.
1	135011104	Kit, Remote Grease Line Hydraulics	1
2	135009786	Drill Bit, 17/64", 118deg Point Angle, Round Shank	1
3	P-1474-0	3/8-16 Insert Nylock Nut S/S	2
4	P-5648	3/8" Flat Zinc Washer	2
5	37C150HCS5Z	3/8-16 x 1.5" Hex Head Cap Screw, GR 5, Zinc	2
6	135009884	Washer, Leveling, 3/8", Iron (For I-Beams)	2
7	135008453	Bracket, Grease Line Mount	1
8	135009909	Cable Tie, 14.5" Long, 120 lbs, Black, Nylon 66	6
9	135011153	Helical Insert Kit, 1/4-28 x 1D	1
		VMV010064 includes all items in Figure 2 Parts List.	

Figure 3

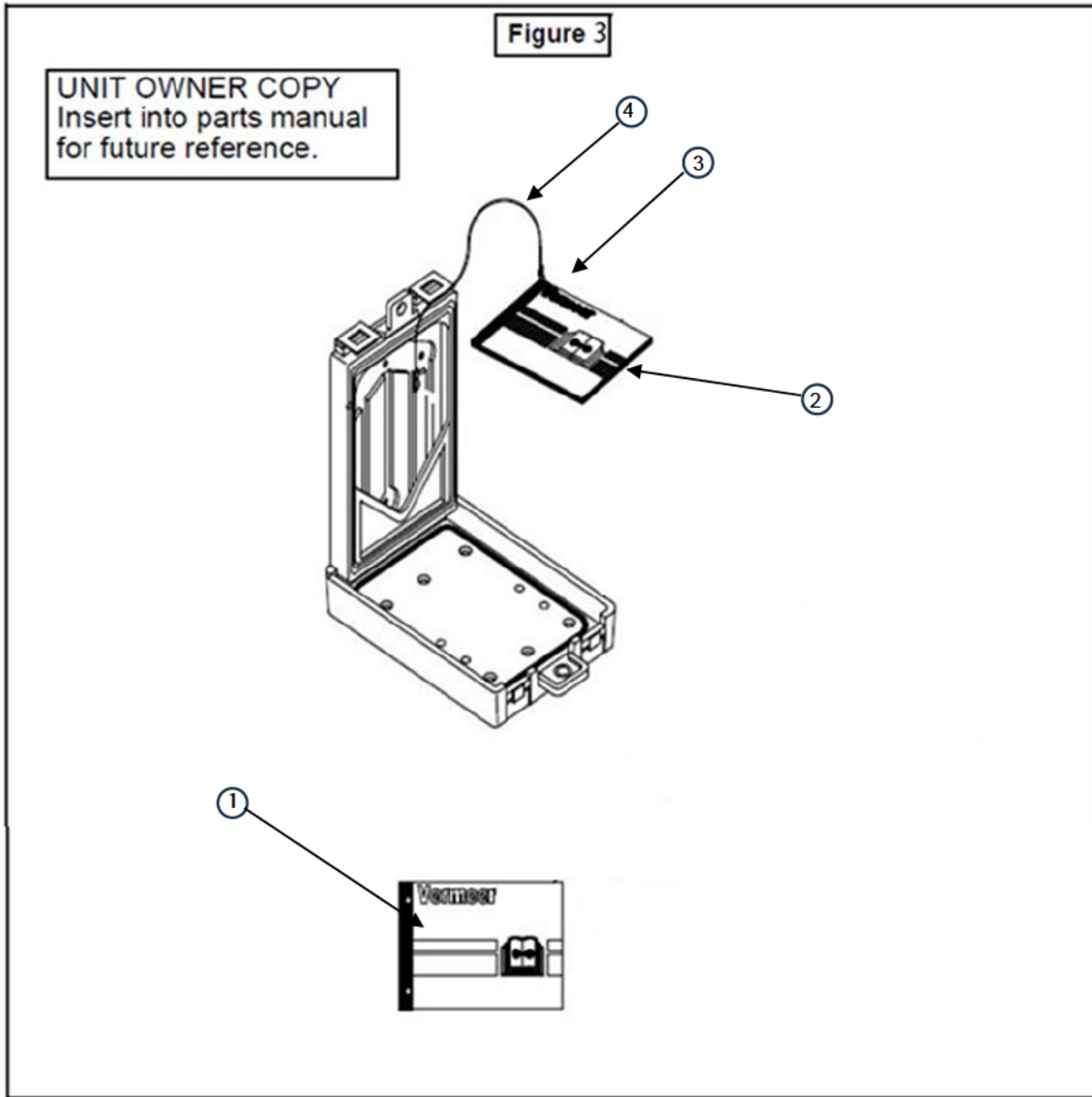

FIGURE 3 Parts List

<u>REF. NO.</u>	<u>PART NO.</u>	<u>DESCRIPTION</u>	<u>VMV00006401 QTY.</u>
1	105400GE0	Manual, HTV873PTO/JTV873PTO Vac Excavator, OM-MM	1
2	105400GE1	Manual, HTV873PTO/JTV873PTO Vac Exc., OM-MM, cabled	1
3	142423001	Crimp Cable (for .068 Dia Cable)	2
4	142945001	Cable - .068 Dia Nylon CT-36.00	1