



Service Bulletin

Bulletin No.: 24-NA-021

Date: March, 2025

INFORMATION

Subject: Information on Malfunction Indicator Lamp (MIL) Illuminated with Any Combination of DTCs P0521, P06DD and/or P06DE Setting

This Service Bulletin replaces PIP5932D. Please discard all versions of PIP5932.

Brand:	Model:	Model Year:		VIN:		Engine:	Transmission :
		from	to	from	to		
Buick	Encore GX	2023	2025	—	—	1.2L Turbo (LBP, LIH)	—
	Envista	2024					
Chevrolet	Trailblazer (VIN M)	2023					
	Trax	2024					

Involved Region or Country	North America
Condition	Some customers may comment that the MIL is illuminated. Technicians may find one or more of the following DTCs set in the Engine Control Module (ECM): <ul style="list-style-type: none"> • P0521 • P06DD • P06DE
Cause	This condition may be caused by the one or more of the following: <ul style="list-style-type: none"> • Engine wiring harness issue • Oil pump debris
Information	Confirm DTC P0521, P06DD and/or P06DE are set in the ECM, the engine oil level is correct, and no driveability concerns exist. Inspection of the oil pressure control solenoid valve and the oil pressure sensor are required if the codes noted have been set. Refer to Testing and Inspection.

Important: Service agents must comply with all International, Federal, State, Provincial, and/or Local laws applicable to the activities it performs under this bulletin, including but not limited to handling, deploying, preparing, classifying, packaging, marking, labeling, and shipping dangerous goods. In the event of a conflict between the procedures set forth in this bulletin and the laws that apply to your dealership, you must follow those applicable laws.

Inspection and Testing of Oil Pressure Sensor

1. Remove the engine oil pressure control solenoid valve electrical connector and inspect for proper terminal tensions, crimps, and locks.
2. Test for 10 to 30 Ω between the test points.
 - Control terminal 2/B & Ignition terminal 1/A of the engine oil pressure control solenoid valve.
3. If within range, inspect the solenoid valve for signs of debris.
 - ⇒ If no debris are found and the concern is not isolated to the engine oil pressure control solenoid valve, refer to *Engine Oil Pressure Sensor Replacement* in SI to **inspect** the engine oil pressure sensor.
4. Disconnect the engine oil pressure sensor and test for less than 10 Ω between the low reference circuit 580 terminal 2 and ECM connector X1-terminal 23.

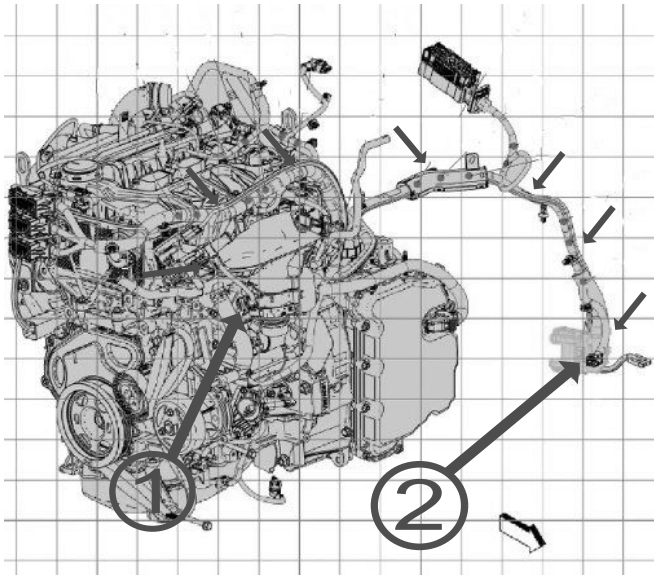

6374708

- If the resistance is within range, tap and manipulate the engine wiring harness between the oil pressure sensor (1) and X125 (2), while monitoring for a change in the resistance reading.
- If the concern is not isolated to the engine wiring harness, reinstall all components and perform the Engine Oil Pump Screening Test.

Engine Oil Pump Screening Test

Important: The purpose of this procedure is to perform two tests of ten cycles each, as described below, or to trigger DTCs P0521, P06DD, P06DE, whichever comes first.

Note: The test should be stopped immediately upon triggering a listed DTC.

1. Park the vehicle in a safe location. Put the transmission in Park and apply the parking brake.
2. Connect the MDI or MDI2 and start GDS.
 - ⇒ Clear all codes in the vehicle, and double check that there are no codes in the ECM before starting the procedure.
3. Module Diagnostics => [K20] Engine Control Module => Data Display => Engine Mechanical Data

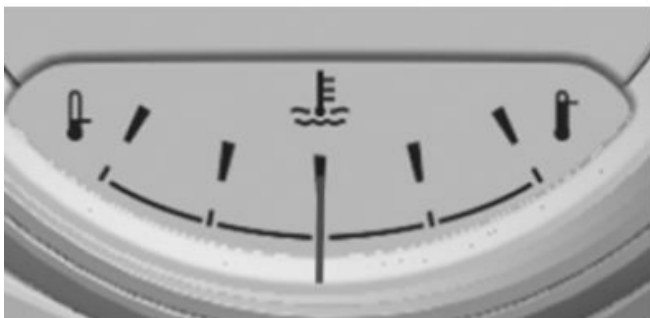

6379891

4. Start and run engine for minimum 15 minutes until the coolant temperature gauge needle is centered in the gauge.
5. Raise the engine speed to 2,000 rpm for 30 seconds.
6. Raise the engine speed to 4,000 rpm for 15 seconds.
7. Release the accelerator pedal and idle 15 seconds.
8. Repeat the 2000 rpm, 4000 rpm, and idle test cycle ten times.
9. Check DTC Display Tab for trouble codes P0521, P06DD, P06DE. Exit Engine Mechanical Data screen to save session log.
 - If any of these DTCs set: P0521, P06DD, P06DE, refer to *Oil Pump Replacement* in SI.
 - If P0521, P06DE, P06DD are not present, turn off the engine, and proceed to step 10.
10. Disconnect scan tool from DLC. Remove key fobs from vehicle. Open door and close door. Wait for 30 seconds to allow modules to power down.
11. Leaving engine off, enter service mode, connect GDS2 and enter Engine Mechanical Data.
12. Start engine. Repeat the test cycle ten more times.
13. Check DTC Display Tab for trouble codes P0521, P06DD, P06DE. Exit Engine Mechanical Data screen to save session log.
 - If any of these DTCs set: P0521, P06DD, P06DE, during this test, refer to *Oil Pump Replacement* in SI.
 - If P0521, P06DD, P06DE are not set during this test, no further action is required. Release the vehicle to the customer.

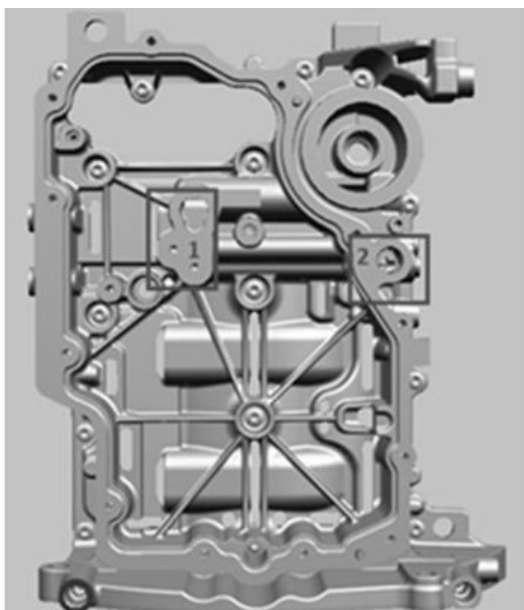

6379894

Caution: If oil pump replacement is needed, ensure the three oil pump oil holes (Area 1) and OCV mounting hole (Area 2) are free of debris BEFORE installing the oil pump and OCV. If debris is found, remove with a lint-free cloth or brush that will not scratch the surface.

Caution: When installing the engine oil pan on the 1.2L (RPO LIH) engine, proper placement of the room temperature vulcanizing (RTV) sealant is critical. Refer to PIP5739 for RTV sealant instructions. Carefully follow the instructions in SI and PIP5739 to ensure proper oil pan installation.

Parts Information

Note: Only select the parts that coincide with the repair performed. Replace the part with the P/N outlined in the Electronic Parts Catalog (EPC) in accordance with the vehicle VIN.

Causal Part	Description	Part Number	Qty
X	PUMP, OIL	55503981	1
N/A	PAN, LWR OIL	25204203	1
N/A	SEAL, O/PMP FLOW CONT VLV	55502517	1
N/A	FILTER, OIL	25206966	1
N/A	OIL	Refer to EPC	As Required

Warranty Information

For vehicles repaired under the Powertrain coverage, use the following labor operation. Reference the Applicable Warranties section of Investigate Vehicle History (IVH) for coverage information.

Labor Operation	Description	Labor Time
4086708*	Inspection and Testing of Oil Pressure Sensor	0.8 hr
Add	Engine Oil Pump Screening Test	1.3 hrs
*This is a unique Labor Operation for bulletin use only.		

Warranty Information

For vehicles repaired under warranty, use:

Labor Operation	Description	Labor Time
4022600	Engine Oil Pressure Sensor Replacement	Use Published Labor Operation Time
4066070	Oil Pump Replacement	

Version	4
Modified	Released June 05, 2024 Revised July 16, 2024 – Updated/Added information throughout the bulletin. Revised August 26, 2024 – Updated the Bulletin Only Labor Operation Number. Revised March 28, 2025 – Added the 2025 Model Year and engine RPO LBP.

