



Service Bulletin

Bulletin No.: 17-NA-394

Date: March, 2025

TECHNICAL

Subject: Squeak, Clunking Type Noise Heard from Rear of Vehicle

Important: This bulletin does not apply to vehicles with RPO 4ZR and/or 4TX.

Brand:	Model:	Model Year:		VIN:		Engine:	Transmission:
		from	to	from	to		
Chevrolet	Colorado	2015	2025			All	All
GMC	Canyon						

Involved Region or Country	North America, Korea
Additional Options (RPO)	Does Not Apply: ⇒ 4ZR ⇒ 4TX.
Condition 1	Some customers may comment on a squeak type noise heard from the rear of the vehicle. Upon further investigation, the technician may diagnose the noise is coming from the rear suspension leaf spring area.
Condition 2	Some customers may comment on a clunking type of noise heard from the rear of the vehicle. Upon further investigation, the technician may diagnose the noise is coming from the rear suspension leaf spring area. Colorado SOP thru 2025 Canyon SOP thru 2025
Cause	These conditions may be due to debris getting between the leaf springs.
Correction 1	Important: Do not add any lubricant to the inserts or springs. Lubricant can attract dirt and debris which can lead to noise and premature insert wear. Some lubricants can also chemically attack the insert material. Install new leaf spring inserts following the procedure below.
Correction 2	Re-torque the joints of the leaf spring assembly following the procedure below.

Important: Service agents must comply with all International, Federal, State, Provincial, and/or Local laws applicable to the activities it performs under this bulletin, including but not limited to handling, deploying, preparing, classifying, packaging, marking, labeling, and shipping dangerous goods. In the event of a conflict between the procedures set forth in this bulletin and the laws that apply to your dealership, you must follow those applicable laws.

Service Procedure (Condition 1)

Prior to performing this bulletin, follow the procedure for Noise Diagnosis - Rear Suspension in SI to determine the source of the noise. Jounce the rear of the vehicle utilizing J 39570 Chassis Ear or equivalent, to aid in locating the source of the noise.

If necessary, road test the vehicle.

1. Raise the vehicle on a frame lift-type hoist. Refer to *Lifting and Jacking the Vehicle*, in SI.

2. Inspect the springs for damage.
 - If damage has been found, refer to *Rear Leaf Spring Replacement*, in SI.
 - If damage has NOT been found, proceed to the next step.

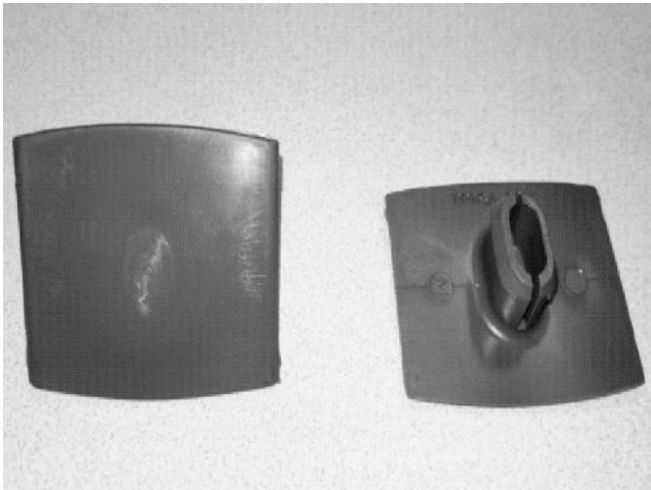

5341853

3. Install new Rear Leaf Spring Inserts using the following procedure:



5358883

Caution: Do NOT damage the finish on Leaf Springs.

- 3.1. On the spring assembly, insert a plastic trim tool or plastic wedge in between the #1 and #2 leaf springs, to access the old insert.



5341855

- 3.2. Push up on insert until it hits the bottom of the spring above it. Then use a suitable cutting tool to cut the stem off from the insert.



5341856

- 3.3. Remove the top portion of the insert, and then remove the bottom portion of the remaining stem.



5341857

- 3.4. Using a rag and degreaser, clean any dirt or grease from between the leaf springs at the insert location

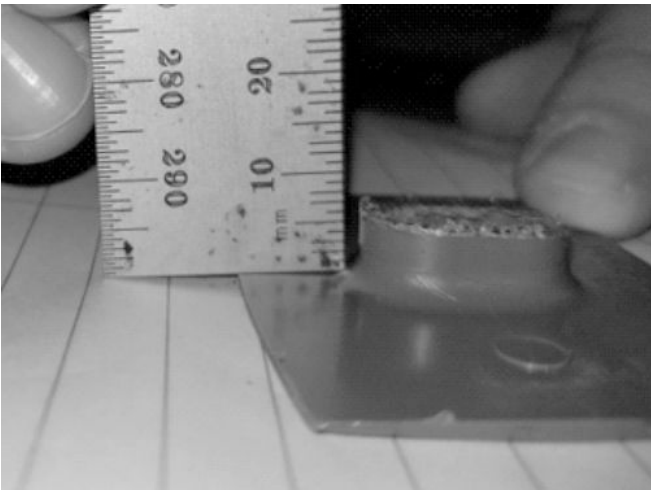

5341859

Caution: Do NOT damage the surface of the new insert when trimming.

- 3.5. Cut the stem of the new insert with a hacksaw or suitable cutting tool. Make sure to leave 6 mm (0.240 in) of the stem.

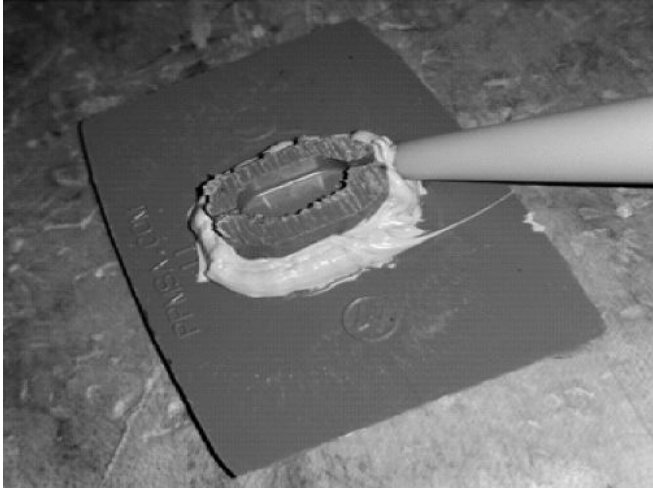

5341861

- 3.6. Apply a small amount of RTV sealer around the remaining portion of the stem.
- 3.7. Install the new insert into the leaf spring. Make sure the stem portion lines up with the slot in the spring. Remove the plastic trim tool or plastic wedge to close the spring and seat the new insert.
4. Repeat step #3 for the 7 remaining inserts.
5. Lower the vehicle to the ground and test drive to verify the repair.

Important: After a new vehicle is delivered to a customer, or new spring tip inserts are installed per this bulletin, new inserts have a break-in period of up to 1610 km (1000 miles), where some noise can be expected. The gray spring inserts are designed to work with absolutely no lubricant. Lubricants of any kind must never be used on the gray spring tip inserts and any remaining lubricant must be completely removed when installing new tip inserts.

Important: If the Service Procedure for Condition 1 fixes the squeak, **DO NOT** proceed to Service Procedure (Condition 2).

Service Procedure (Condition 2)

1. Support the vehicle at curb height when re-torquing the leaf spring U-bolt nuts.

Note: **DO NOT** remove the fuel tank.

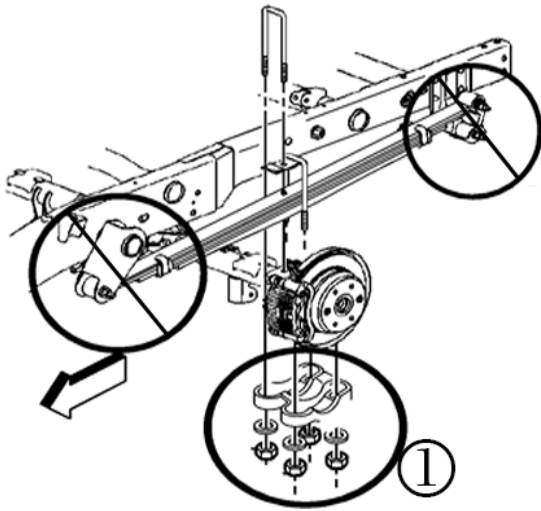

4966874

2. Loosen the left leaf spring anchor plate U-bolts (1).
3. Re-torque the anchor plate U-bolts (1). Refer to SI for torque specifications.
4. Repeat steps 2 and 3 for the right-side leaf spring.
5. Re-test the vehicle for the same clunking noise. If the issue remains, follow the regular repair procedure.

Parts Information

Causal Part	Description	Part Number	Qty
N/A*	Leaf Spring Insert	87828827	8
	RTV Sealer	88864346 (In Canada, 88861418)	1

*For warranty transactions, **DO NOT** mark this/these parts as the Causal Part. Enter the word "Bulletin" in the Causal Part Description free-flow text field.

Warranty Information

For vehicles repaired under the Bumper-to-Bumper coverage (Canada Base Warranty coverage), use the following labor operation. Reference the Applicable Warranties section of Investigate Vehicle History (IVH) for coverage information.

Labor Operation	Description	Labor Time
8080508*	Rear Leaf Spring Insert Replacement (Condition 1)	0.5 hr.
8080398*	Retorque Bolts / Road Test (Condition 2)	0.6 hr.

*This is a unique Labor Operation for Bulletin use only.

Version	12
Modified	<p>Released December 08, 2017</p> <p>Revised February 09, 2018 – Updated steps for Service Procedure (Condition 2) and Warranty Information (Condition 2).</p> <p>Revised February 13, 2018 – Updated the Warranty Information (Condition 2).</p> <p>Revised July 11, 2018 – Added 2018–2019 model years.</p> <p>Revised August 06, 2019 – Updated Procedure, Parts and Warranty Information for Spring Insert Replacement.</p>

Revised March 04, 2021 – Added 2020–2021 Model Years, Removed Breakpoint from Condition #2, Updated Export Countries

Revised November 15, 2021 – Added 2022 Model Year to Condition # 2, and an Important after Step #5 in Service Procedure (Condition 1).

Revised May 01, 2023 – Revised Part Information with Updated Insert Part Number.

Revised October 06, 2023 – Added 2023–2024 Model Years and Removed Break Points in Condition 1 section.

Revised January 10, 2025 - Added 2025 Model Year.

Revised February 25, 2025 - Added Important Statement in the Correction 1 section.

Revised March 31, 2025 - Removed All the Countries Leaving the N.A. and Adding Korea to Involved Region or Country section.

