

**ATTENTION:**  
 GENERAL MANAGER   
 PARTS MANAGER   
 CLAIMS PERSONNEL   
 SERVICE MANAGER

IMPORTANT - All Service Personnel Should Read and Initial in the boxes provided, right.

© 2025 Subaru of America, Inc. All rights reserved.



QUALITY DRIVEN® SERVICE

**SERVICE BULLETIN**

**APPLICABILITY:** 2019-24MY Ascent

**NUMBER:** 12-258-24

**SUBJECT:** Sunroof Seal Installation Tips

**DATE:** 03/18/25

**INTRODUCTION:**

This bulletin provides additional examples, diagnostics tips and installation tips as helpful aids to be used when working with sunroof seals and sunroof frame assemblies on Ascent models. The sunroof seal is a one-time use part and should be replaced anytime the sunroof frame assembly is removed from the vehicle. Refer to the information below along with the details provided in the applicable Service Manual when performing any service procedure regarding sunroof repair.

**IMPORTANT:** 3M Adhesive Promotor 4298 (p.n. **SOA635148**) **MUST** be ordered with the new sunroof seal. If required, the 3M Adhesion Promoter 4298 can be sourced from an outside vendor.

**EXAMPLES OF SUNROOF SEAL DAMAGE:**

**TYPE A: Sunroof Seal is Floating**



**TYPE B: Tearing of the Sunroof Seal**



**CAUTION: VEHICLE SERVICING PERFORMED BY UNTRAINED PERSONS COULD RESULT IN SERIOUS INJURY TO THOSE PERSONS OR TO OTHERS.**

Subaru Service Bulletins are intended for use by professional technicians ONLY. They are written to inform those technicians of conditions that may occur in some vehicles, or to provide information that could assist in the proper servicing of the vehicle. Properly trained technicians have the equipment, tools, safety instructions, and know-how to do the job correctly and safely. If a condition is described, DO NOT assume that this Service Bulletin applies to your vehicle, or that your vehicle will have that condition.

**Subaru of America, Inc. is ISO 14001 Compliant**

ISO 14001 is the international standard for excellence in Environmental Management Systems. Please recycle or dispose of automotive products in a manner that is friendly to our environment and in accordance with all local, state and federal laws and regulations.

*Continued...*

### TIP 1: SUNROOF GLASS CONDITION

When working with sunroof glass, ALWAYS inspect the glass condition. It is possible for burrs to exist on the corner section of the glass which can cause damage to the sunroof seal. These burrs can be CAREFULLY smoothed out using fine grit sandpaper or emery cloth.

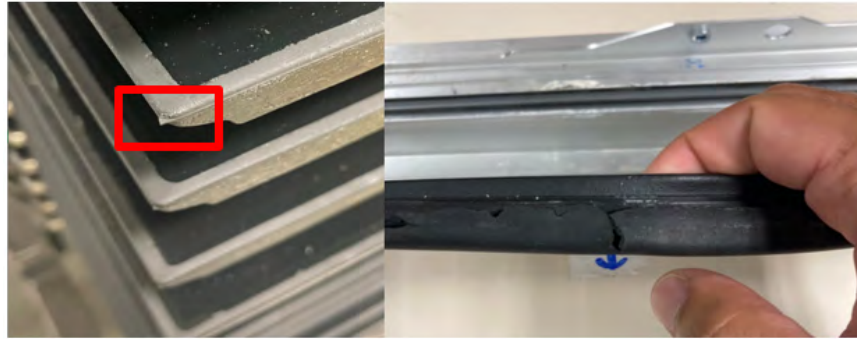

### TIP 2: DOUBLE-SIDED TAPE LOCATED ON SUNROOF FRAME

There is a section of double-sided tape on the front and rear section of the sunroof frame. This tape functions as a hook to help secure the seal. The yellow plastic section on the tape **DOES NOT REQUIRE REMOVAL** and **MUST NEVER BE REMOVED**.

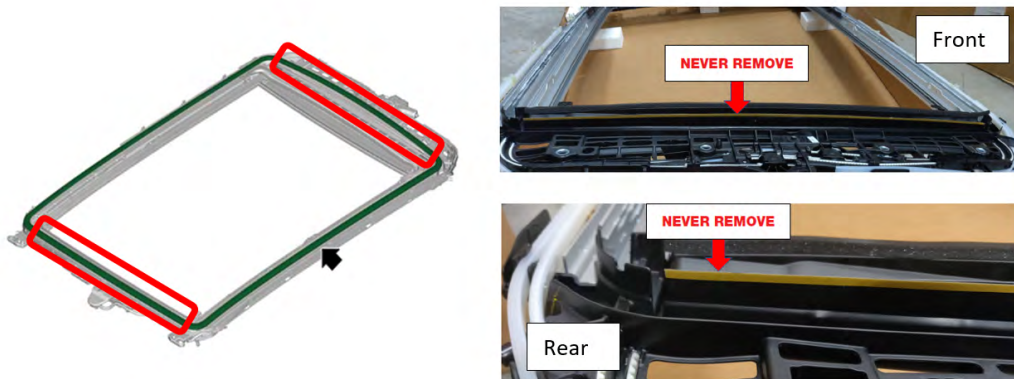

### TIP 3: RAIL ASSEMBLY CLEANING / PREPARATION

When replacing the sunroof seal on the rail, proper cleaning, degreasing, and preparation is required. ALWAYS remove any grease and debris from the seal contact points.

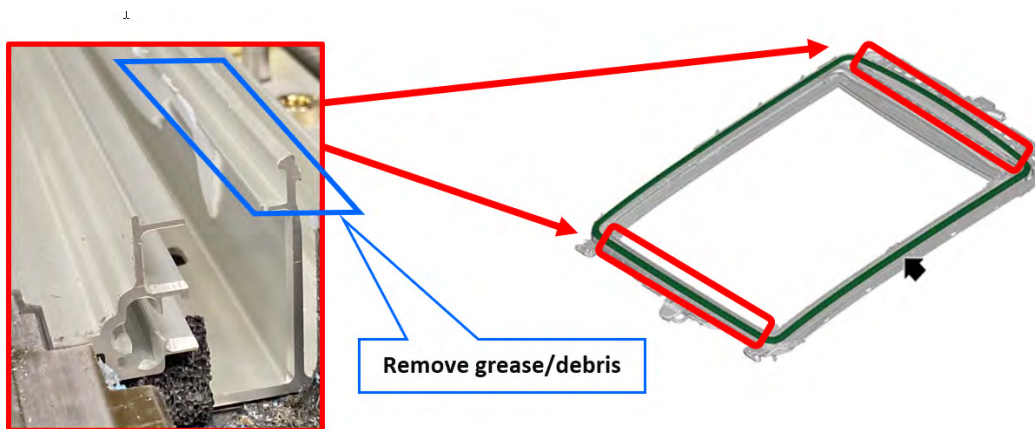

*Continued...*

#### TIP 4: RAIL ASSEMBLY CLEANING / PREPARATION

1. ALWAYS remove any remnants of double-sided tape from the corners of the rail assembly.
2. Remove and grease/debris from the adhesion area.
3. Prepare the area by applying 3M Adhesion Promoter 4298 (p.n. SOA635148) and allow one minute to rest. When ordered, the adhesion promoter will come with segment of Teflon tape. This tape is not required for this procedure and can be discarded.
4. Apply a second coat of 3M Adhesion Promoter 4298 and allow one minute to rest.



**NOTE:** If required, the 3M Adhesion Promoter 4298 can be sourced from an outside vendor.

**CAUTION:** Slowly apply the second coat. This will help prevent the initial coat from peeling off.

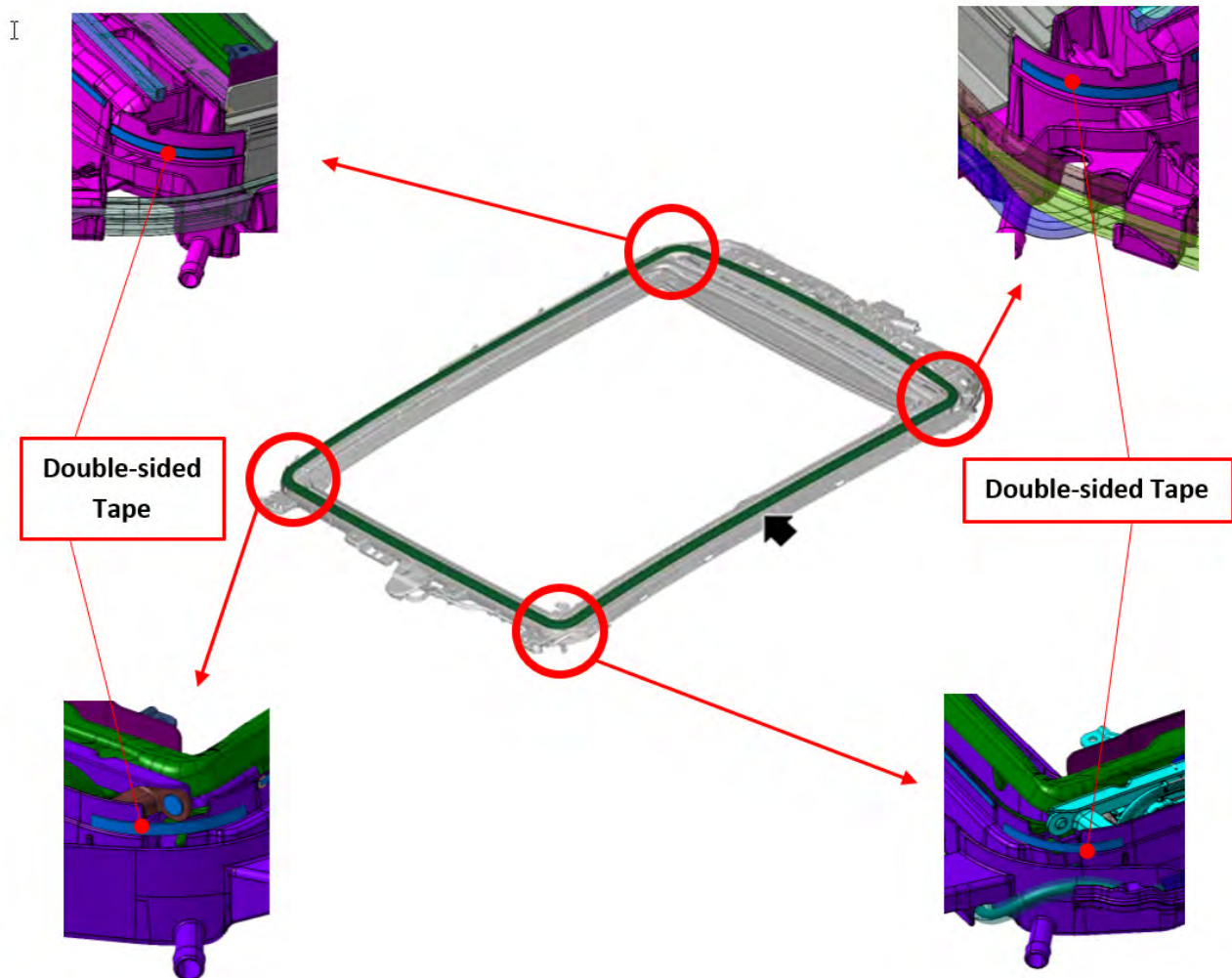

**NOTE:** Up to \$5.00 can be claimed in sublet for the use of outside vendor sourced adhesion promoter. If SOA635148 is billed to the repair order, the claim in sublet will not apply.

*Continued...*

## TIP 5: SUNROOF SEAL ALIGNMENT

Locate the alignment triangles on each corner of the sunroof seal and the markings on the rail assembly.

**ALWAYS** confirm the sunroof seal alignment prior to removal of the seal adhesion release strip.

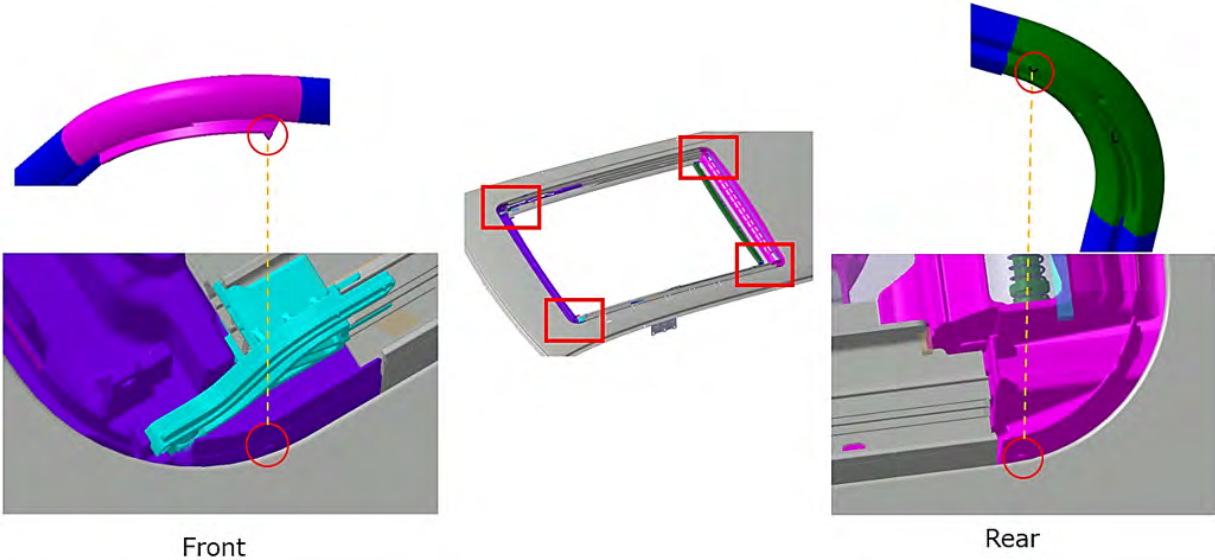

## TIP 6: SUNROOF SEAL CORNER INSTALLATION

1. Fully peel off the adhesion release strip. DO NOT leave any remaining pieces attached.



2. Using your fingers, squeeze and hold the inner section of the seal. This will provide room for installation.
3. Install the sunroof seal while keeping the seal in the squeezed position. Maintain alignment of corners with the marking while installing from a diagonal angle.

*Continued...*

4. Firmly press the double-sided tape to the body using a plastic trim tool or screwdriver with protective tape attached.

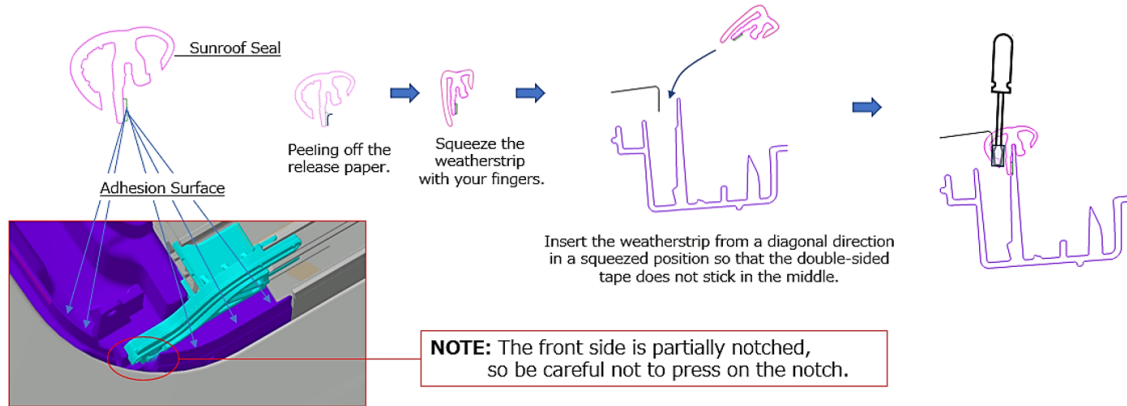

### TIP 7: CONFIRM THE POSITIONING OF THE CORNERS

ALWAYS confirm the double-sided tape section of the seal is evenly adhered to the outside of the rail assembly.

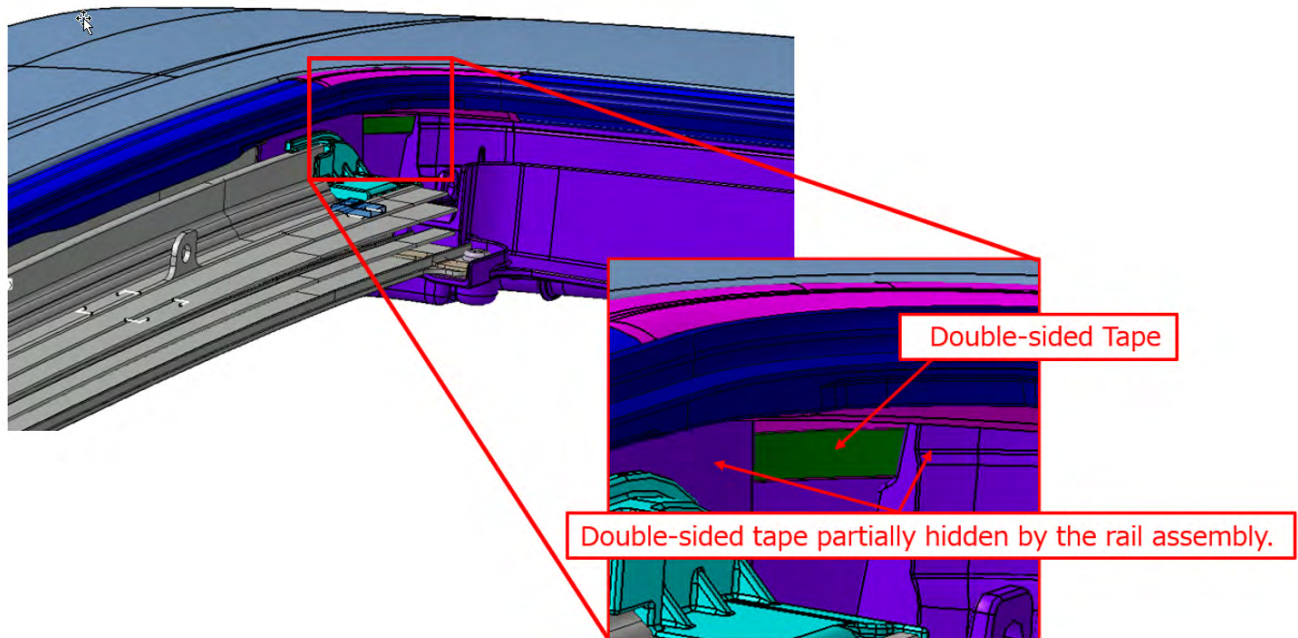

*Continued...*

### TIP 8: EVENLY SECURING THE SUNROOF SEAL

To prevent any wrinkles or pinching, it is vital to secure the seal in the correct order. Press down the seal into the rail assembly in the positions in the order shown below.

**NOTE:** An audible click sound is heard when the seal is fully seated.

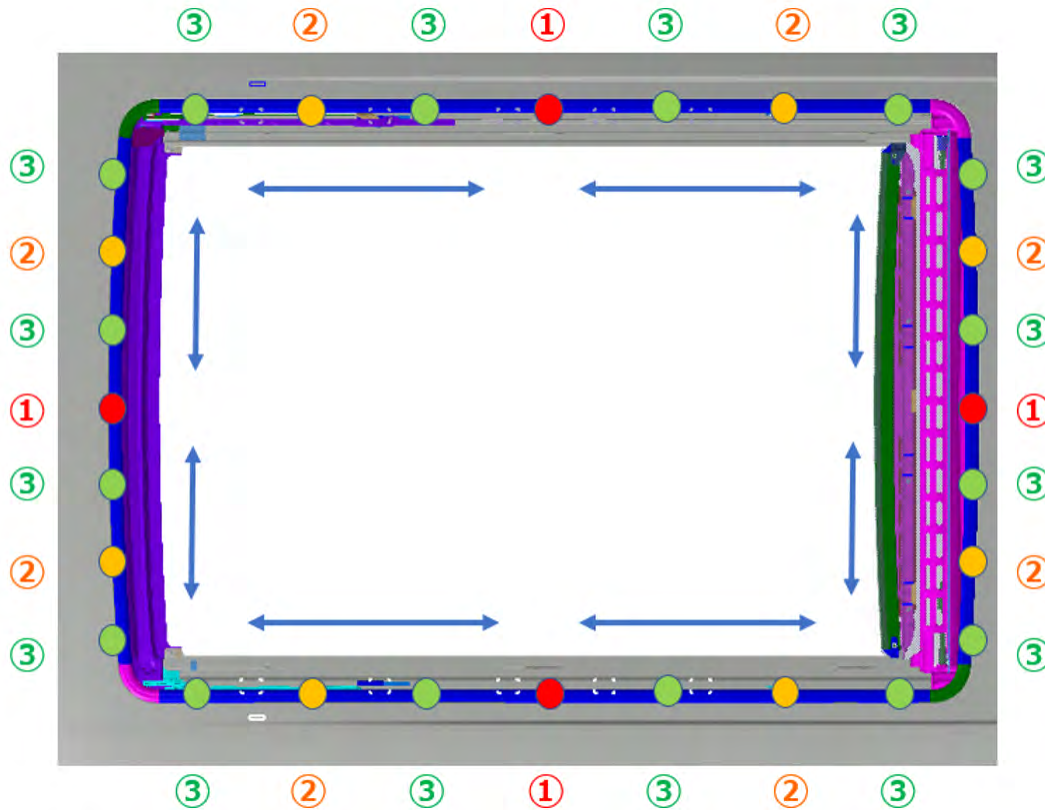

**IMPORTANT:** Always inspect the installed height of seal after it is fully seated. Confirm the roof panel and the seal height are within +/- 2mm of each other.

### TIP 9: RAIL ASSEMBLY INSPECTION

ALWAYS confirm the rear foam pad has not fallen or peeled off. Reposition as required. Clean any debris that may have accumulated within the area.

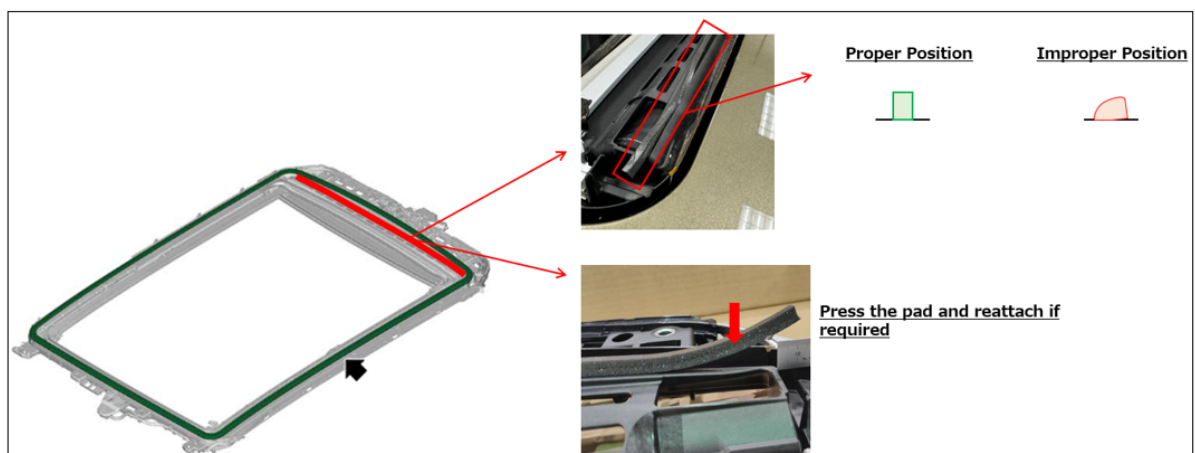

*Continued...*

## TIP 10: SUNROOF GLASS INSTALLATION

1. Confirm the sunroof is in the closed position.
2. CAREFULLY place the front and rear glass sections into the correct positions on the rail assembly.
3. Install the NEW glass mounting bolts **hand tight only**.
4. Have a second person push the front section of the glass in a downward direction (from outside) and push the rear section of the front glass in the upward direction (from inside).
5. Torque all the mounting bolts with the glass in this position.
6. Confirm proper operation and inspect for any possible gaps. Once confirmed, install the deflector and cover.
7. Perform a function test of the sunroof assembly.
8. Perform a water leak test. Ensure all sunroof drains are working properly.



### IMPORTANT REMINDERS:

- SOA strongly discourages the printing and/or local storage of service information as previously released information and electronic publications may be updated at any time.
- Always check for any open recalls or campaigns anytime a vehicle is in for servicing.
- Always refer to STIS for the latest service information before performing any repairs.