

ADDRESSEES	: Owners and operators ABC Customer Care and Parts Source
VEHICLE MODEL	: CX35/CX45 vehicles with electric cooling fan drive
MANUAL CHAPTER	: 02.34 Traction engine – Cooling system
BULLETIN TYPE	: Service information
DATE	: March 27 th , 2025
SUBJECT	: Removal and installation of cooling system radiator
CONDITIONS	: This service bulletin does not entitle to any reimbursement.

INTRODUCTION

This service bulletin provides step-by-step instructions on how to remove and install the radiator of the engine cooling system.



Figure 1: Radiator compartment on CX45

JOB QUALIFICATION

An experienced automotive technician is required to perform this task.

SPECIAL TOOL

Hose (length: 25 cm/10 inches) with unique coupling for radiator drain nipple: VH11836088

Continued on next page.

PREPARATIONS:

- Park the coach on a level-surfaced service pit.
- Apply the parking brake and shut off the engine.
- Switch off all systems and turn off the battery master switch.
- Turn off the mechanical battery switch.
- Put a “DO NOT OPERATE” tag on the instrument panel.
- **Read the entire procedure before beginning to work.**



WARNING!

Always observe safe shop practices.



PROCEDURE

Step	Action
1	Open the engine compartment access door in the rear wall of the vehicle.
2	Open the radiator compartment access door located on the left-hand side at the very rear.
3	Drain the engine cooling system as described in “STEP 3 IN DETAIL”.
4	Remove the radiator as described in “STEP 4 IN DETAIL”.
5	Install the radiator as described in “STEP 5 IN DETAIL”.
6	Fill and bleed the engine cooling circuit. The coolant level must be between the “MIN” and “MAX” marks on the expansion tank.
7	Check the coolant expansion tank filler cap rubber seal for damage. Change the filler cap, if necessary.
8	Install the filler cap on the coolant expansion tank.
9	Open the interior heating circuit isolating valves.
10	Drive the engine at operating temperature.
11	Stop the engine and check the coolant level as soon as the system has cooled down completely. If necessary, top up with coolant.

End of procedure.

Continued on next page.

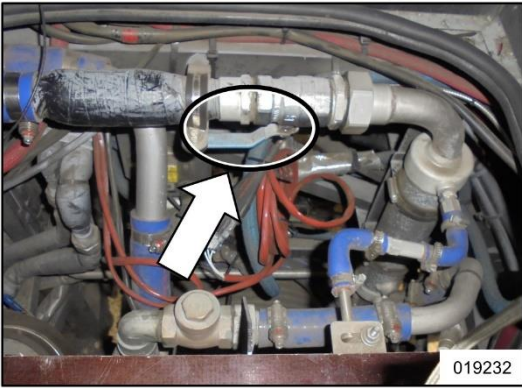
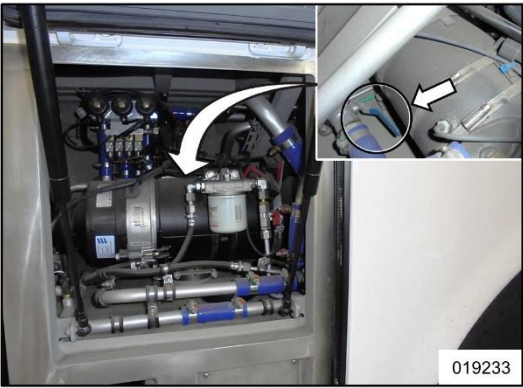
STEP 3 IN DETAIL: To drain the engine cooling circuit

Step	Action
<p>3.1</p>	<p>To permit draining the engine cooling circuit without draining the interior heating circuit, close the interior heating circuit isolating valves:</p> <ol style="list-style-type: none"> Inside the vehicle, above the engine (Figure 2), open the floor trap and close the main isolating valve in the supply line of the interior heating circuit. To do this, turn the valve lever clockwise until the lever is perpendicular to the coolant line. At the left-hand side of the vehicle, in front of the drive axle (Figure 3), open the exterior access door and close the main isolating valve in the return line of the interior heating circuit. This valve is located behind the coolant heater, on the right-hand side of the water pump. To do this, turn the valve lever clockwise until the lever is perpendicular to the coolant line. <div style="display: flex; justify-content: space-around; align-items: flex-end;"> <div style="text-align: center;">  <p>019232</p> <p>Figure 2</p> </div> <div style="text-align: center;">  <p>019233</p> <p>Figure 3</p> </div> </div>
<p>3.2</p>	<div style="display: flex; align-items: flex-start;"> <div style="margin-right: 10px;">  </div> <div> <p>WARNING!</p> <p>Carefully slacken the filler cap on the coolant expansion tank and let the pressure escape. Once all pressure escaped, continue to turn.</p> </div> </div> <p>Unscrew the filler cap from the expansion tank and remove it.</p> <div style="text-align: center; margin-top: 20px;">  <p>Figure 4</p> </div>

Continued on next page.

3.3

At the bottom of the radiator, drain the cooling circuit through the drain nipple using the special tool VH11836088.



Figure 5

3.4

At the top of the radiator:

- a. Release the hose clamps (1) at the radiator. Pull the coolant hose away from the radiator to detach it.
- b. Release the hose clamp from the bleeding line (2) and pull the line from the radiator.
- c. Disconnect the ground cable (3) from the radiator.

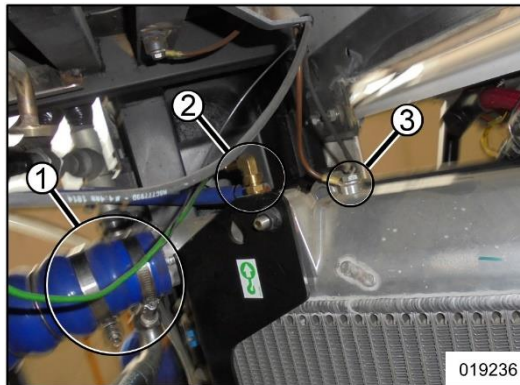

Figure 6

3.5

At the bottom of the radiator, release the hose clamps. Pull to detach the coolant hose.

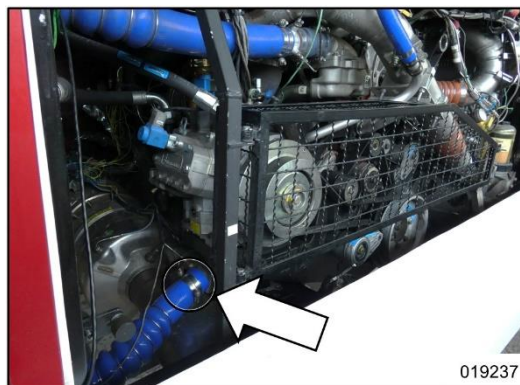
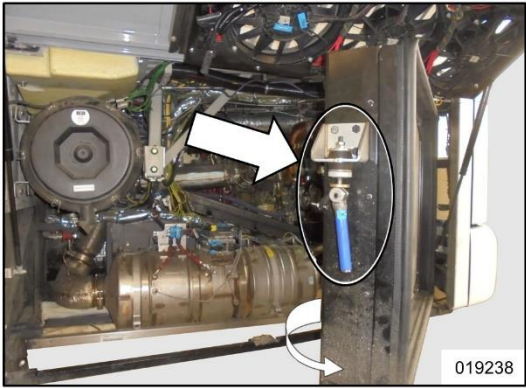

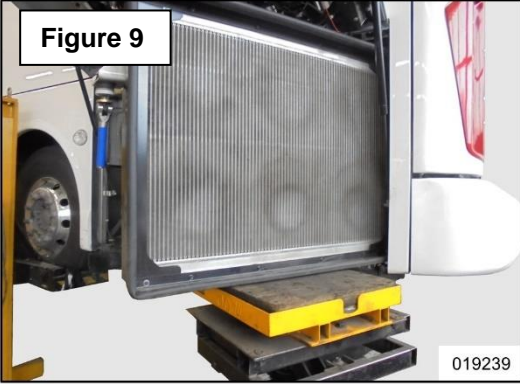
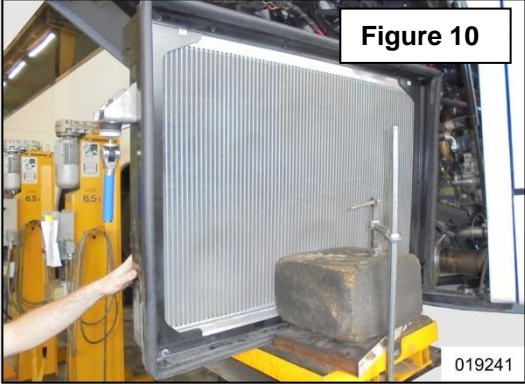
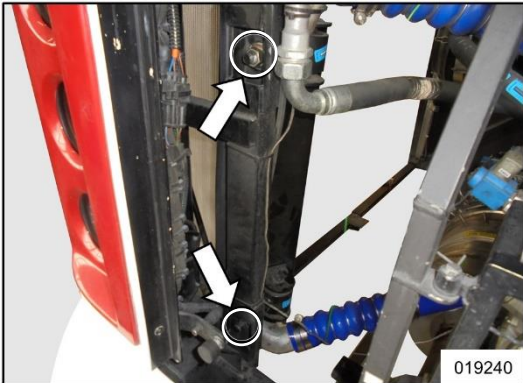

Figure 7

Continued on next page.

STEP 4 IN DETAIL: To remove the radiator

Step	Action
<p>4.1</p>	<p>Pull the operating handle of the locking system outwards to unlock the radiator assembly and swing the assembly out.</p>  <p style="text-align: right;">Figure 8</p>
<p>4.2</p>	<p> CAUTION! The radiator core contains thin aluminum fins. Be careful not to bend these fins.</p> <p>Roll a lifting device under the radiator (refer to Figure 9). Wooden blocks should be used in a manner that prevents the radiator from turning over when disconnected from the body (Figure 10 shows an example).</p>  
<p>4.3</p>	<p>Disconnect the radiator assembly from the body by removing the nuts of the upper and lower rubber-insulated hinges (Figure 11).</p>  <p style="text-align: right;">Figure 11</p>

Continued at next page.

4.4	Carefully remove the radiator from the compartment.
4.5	In the radiator compartment , cover all apertures to prevent debris from entering.
4.6	On the radiator , cover all apertures to prevent debris from entering.

STEP 5 IN DETAIL: To install the radiator

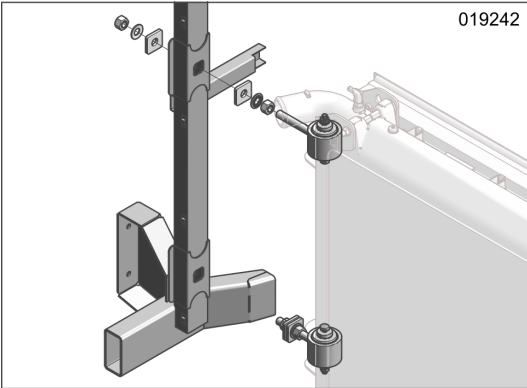
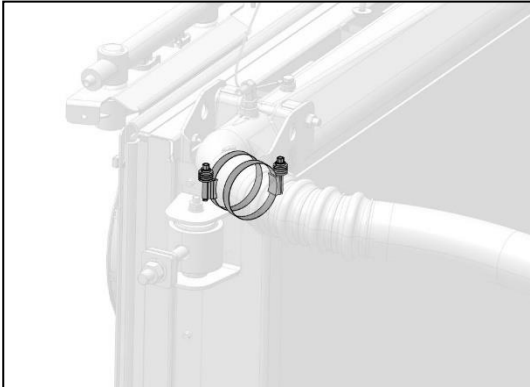
Step	Action
5.1	<p>Only if the radiator that must be installed is a new one: transfer the radiator locking device and the two rubber-insulated hinges to the new radiator.</p> <ul style="list-style-type: none"> • Radiator locking device bracket screws: 42 ± 6 Nm (30 ± 5 ft.lb) • Bolts of rubber insulated radiator hinges: 42 ± 6 Nm (30 ± 5 ft.lb)
5.2	Remove the covers from the apertures.
5.3	Bring the radiator assembly to the proper height using the lifting device.
5.4	<p>Carefully move the radiator assembly so that you can insert the threaded ends of the radiator hinges into the square-shaped holes of the body tubing.</p> <div style="text-align: center;">  <p>019242</p> </div> <p style="text-align: right;">Figure 12</p>
5.5	Apply “Anti-Seize Lubricant” or similar to the threaded end of the radiator hinges.
5.6	Secure the radiator hinges to the body tubing by using the square-shaped washers and serrated conical spring washers. Tighten the nuts to a torque of 180 ± 25 Nm (130 ± 20 ft.lb).
5.7	<p>Connect the coolant hoses. The connections have two clamps side by side with the screw housings separated from at least 90° (Figure 14 shows an example). Reconnect the bleeding line and ground cable to the radiator.</p> <p>Tightening torques:</p> <ul style="list-style-type: none"> • Coolant hose clamps: $7 \pm 0,5$ Nm (5 ± 0.4 ft.lb). • Bleeding line hose clamp: $5 \pm 0,5$ Nm (4 ± 0.4 ft.lb). • Grounding screw: $25 + 5$ Nm (18 ± 4 ft.lb). <div style="text-align: center;">  </div> <p style="text-align: right;">Figure 13: Proper hose clamp installation</p>

Continued on next page.

5.8 Lower the lifting device until the radiator assembly is no longer supported.

5.9 **With the radiator assembly not in the home position and the handle of the locking device in the horizontal position**, measure the distance between the bottom of the plastic pressure disc (3) and the washer (4). This distance should be 0.7 inches (18 mm) to achieve a sufficient clamping force, keeping the radiator assembly in place once locked in the fully home position.

If necessary, change the distance as follows:

- a. Slacken both locknuts (1).
- b. Turn the knurled nut (2) until the predetermined distance has been reached.
- c. Tighten both locknuts (1) again.

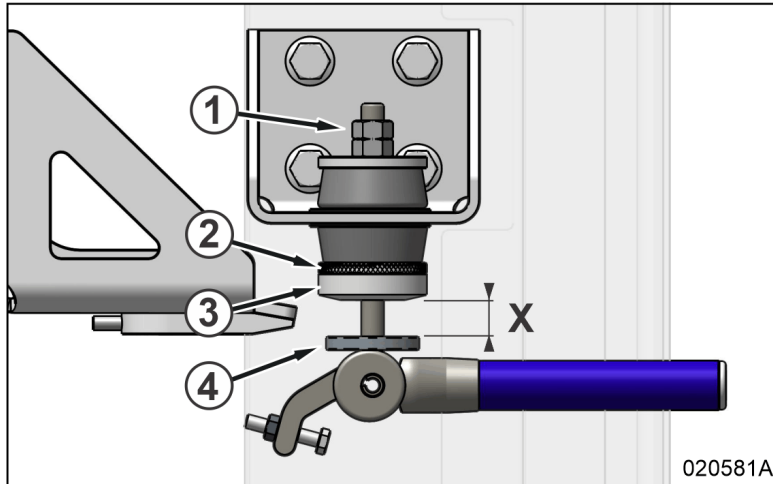

Figure 14: Locking device set-up

5.10 Hinge the radiator assembly to its home position and adjust the position of the locking device accordingly.

The catcher should be positioned so that the radiator assembly is slightly supported when it is pushed into the fully home position. Adjustment is done by repositioning the locking catcher (2, Figure 15) on the body tubing (1, Figure 15).

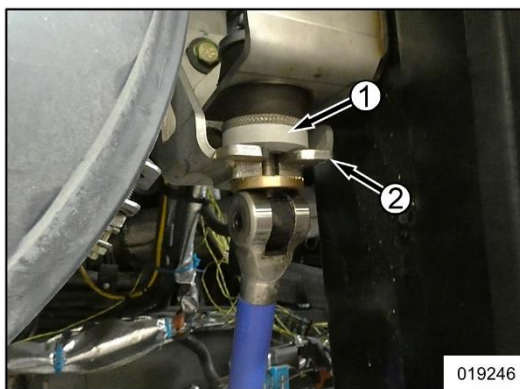

Figure 15: Radiator assembly locking device

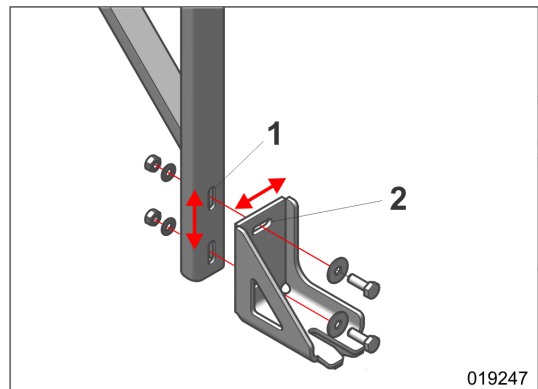

Figure 16: Locking catcher position adjustment

1. Plastic pressure disc
2. Locking catcher

Continued on next page.

5.11

With the radiator assembly in the home position, verify the position of the radiator assembly relative to the cooling fans mounting plate. There should be no gap between the cooling fans mounting plate and the radiator assembly all around (refer to Figure 17).

This can be checked as follows:

- a. Apply a continuous layer of Vaseline or a similar product all around on the closing rubber of the radiator assembly.
- b. Close the access door containing the cooling fans.
- c. Open the access door containing the cooling fans.
- d. Check whether a continuous print of "Vaseline" is visible on the cooling fans mounting plate.
 - If so, the alignment of the radiator assembly concerning the cooling fans mounting plate is correct. Continue with step 5.13.
 - If not, you must reposition the radiator assembly, as explained in step 5.12.

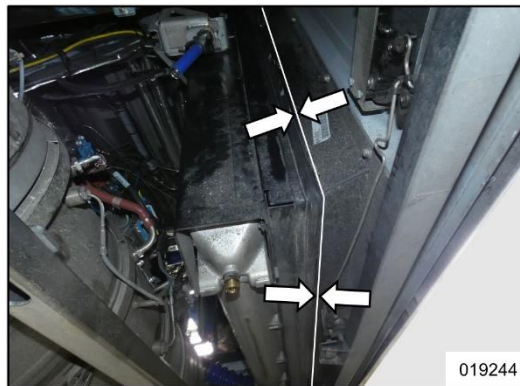

019244 **Figure 17**

5.12

Reposition the radiator assembly.

- **Vertically and horizontally adjustment:** the oversized square holes enable vertical as well as horizontal position adjustment (refer to Figure 18).
- **Depth adjustment of locking device concerning catcher:** can be set with the small screw on the locking catcher (refer to Figure 19). If adjustment must be made, first remove the screw, clean with Loctite 7063, and apply Loctite 222.

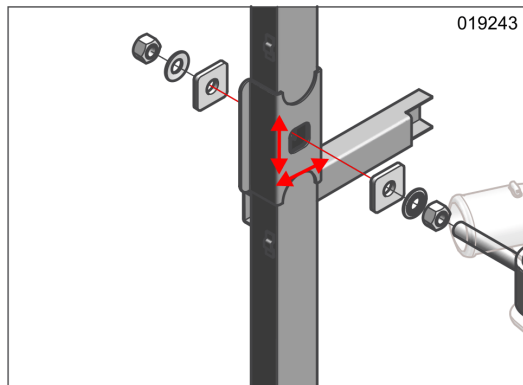

019243 **Figure 18**

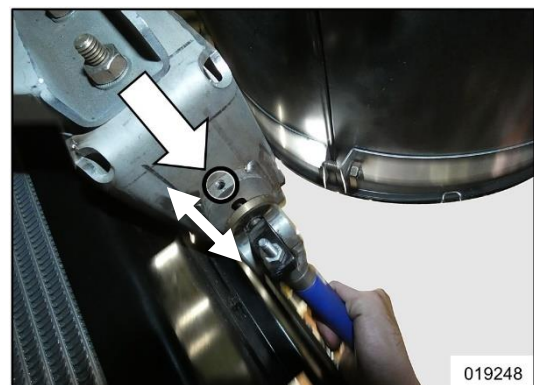

019248 **Figure 19: Use the small screw to adjust the depth of the locking device concerning the catcher**

Continued on next page.

5.13

Adjust the locking device handle end position. Figure 20 shows a proper tensioned locking system (operating handle 20° to 30° beyond vertical position). The handle end position can be set with the stop screw (1).

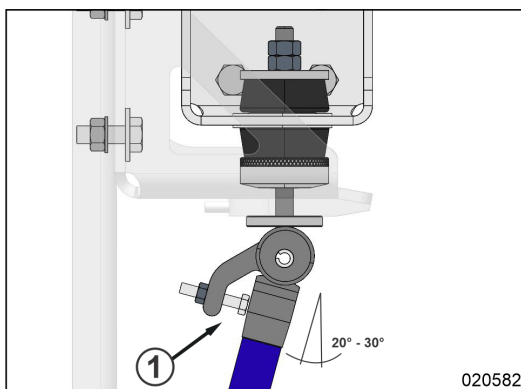
**Figure 20****HELP DESK**

If there are any questions, please call ABC Customer Care & Parts Source toll-free for guidance on 1-877-427-7278. Listen for the prompts for warranty and select that option.

DISCLAIMER

The procedures contained herein are not exclusive. VDL Van Hool cannot possibly know, evaluate, or advise the transportation industry of all conceivable ways in which a procedure may be undertaken or of the possible consequences of each such procedure. Other methods may be equally reasonable or even more effective, depending on the specific circumstances involved. Each carrier that uses the procedures herein must thoroughly ensure that neither the safety of its employees or agents, nor the safety or usefulness of any products, will be jeopardized by any procedure selected.

INFORMATION HANDLING

Important additions and modifications regarding technical information not yet included in the manual will be communicated through Service Bulletins.

VDL VAN HOOL CUSTOMER PORTAL

Consult the customer portal regularly for the latest service documentation. In addition to the maintenance manual, you will also find the operating manual and the spare parts catalogue of your vehicle on the customer portal. The customer portal is accessible through www.vdlvanhool.com/MyVDL_Van_Hool, and only with a code (password) from VDL Van Hool. If you do not have a password yet, request it by using the link on the VDL Van Hool website.