



SIB 33 01 24 SERVICE SOLUTION: Chassis Calibration Failure

2025-03-05

This Service Information Bulletin replaces SIB 33 01 24 **dated July 11, 2024.**

What's New (Specific text highlighted):

- KA2 Added
-

MODEL

Model	Type Code	Model Description
KA1	0M23	R 1300 GS
KA2	0M33	R 1300 GS Adventure

SITUATION

The Dynamic Suspension Adjustment (DSA) chassis cannot be calibrated. Various causes can lead to this fault.

PROCEDURE

Diagnostic Procedure to determine a root cause:

Pre-Check items:

- Update the ISTA version to 4.45.10 or newer.
- Work on the vehicle at room temperature of at least 68°F (20°C). If outside temperatures are cold, allow the vehicle to warm up before working on it.
- Set vehicle to drive mode: "Road" and ride height to "Auto".
- Check the suspension struts for freedom of movement and contamination.
- Check the ride height sensors (position, correct? linkage bent?)
- Connect the vehicle to a suitable battery charger. The vehicle voltage must be supplied with at least 13.9 V.
- Clear fault memory.
- Carry out a test ride (If necessary to adjust the chassie).
- Read out fault memory again.

Notice: Only vehicle with adequate power supply of 14 Vdc and 20 A can be correctly diagnosed and corrected.

Note at this point if there are no fault memory entries, the action is completed and no further action is required.

If there are still faults, please perform the following diagnostic path:

Diagnosis:

- Thoroughly process the fault memory using the Guided Diagnosis; in particular, the following faults indicate problems with the vehicle electrical system, the battery, or an insufficient voltage supply:
 - 0x801C5E - Chassis, vehicle electrical power system: Turn-off
 - 0x801C5F - Chassis, vehicle electrical power system: Degradation

Copyright ©2025 MOTORRAD USA, a division of BMW of North America, LLC. All Rights Reserved

- 0x801CAC - Energy management: Shutdown concept level2
 - 0x801CB1 - Energy management: Shutdown concept level1
 - 0x801CBE - Battery Guard: State of charge implausible
 - 0x801CBF - Energy management: State of charge implausible
- Use ISTA to carry out the “Calibrate complete hydraulics” test module and follow the instructions. Observe/check the stroke of the preload adjusters during calibration.
 - Did the chassis lower after the calibration?
 - If yes and there are no more chassis fault memories displays, then the bike is working as designed.
 - If Not Continue the checks
 - If the chassis does not move into the high and low positions or the chassis remains in the high position,
 - Visually check system for leaks.
 - carry out a visual inspection of the snap fasteners of the hydraulic lines. Snap fasteners with retaining clips that are open due to bending can come loose during calibration. If you notice a loosened snap fastener, bend the retaining clips slightly together, connect the snap fastener correctly and slide the rubber retainer onto the clips.
 - Delete the fault memory and calibrate the complete hydraulics again. Repeat one more time if necessary.

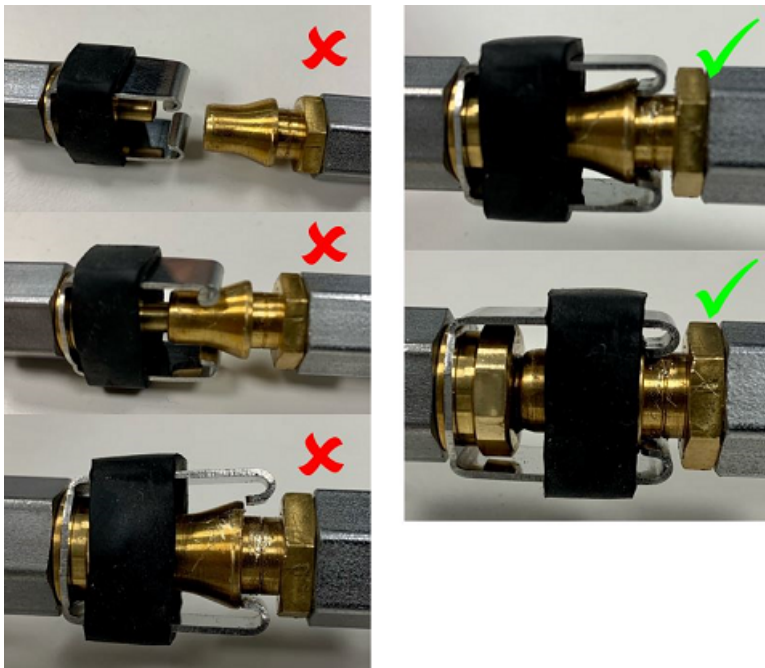

If calibration is not possible after the above-mentioned checks.

- Front and rear preload adjusters / suspension struts move up and down. Calibration failed several times. You must replace the hydraulic pump (do not exchange pumps from other vehicles).

Before replacing the hydraulic pump, carry out the “Hydraulic suspension pump actuation” test module in ISTA and then the “lower chassis” test module. Please ensure that the chassis is completely lowered. If in doubt, repeat the “Lower Chassis” procedure again and press the chassis downwards as well.

Note: Before replacing the hydraulic suspension pump, make sure that the chassis is in the low position. If the chassis is not in the low position, the suspension struts that are not in the low position must be replaced as well

Copyright ©2025 MOTORRAD USA, a division of BMW of North America, LLC. All Rights Reserved

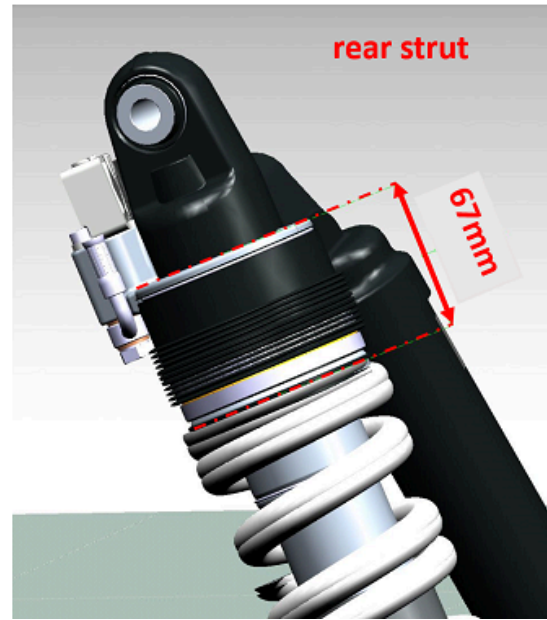
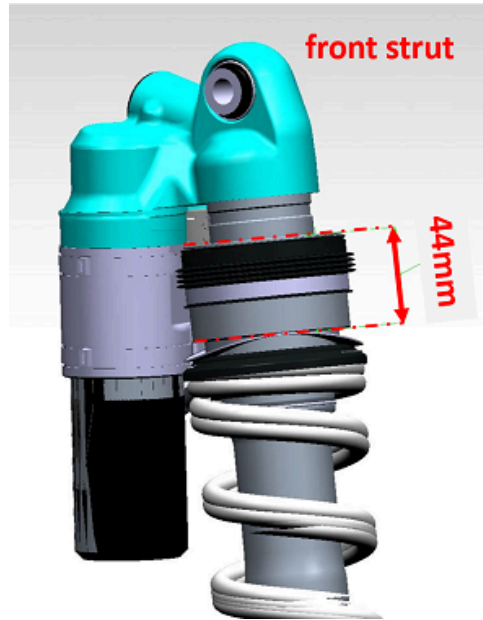

NOTICE: Only create S

TSARA case once all of the measures have been completed and there has been no solution. Make sure to follow all WPPM (Warranty Policy and Procedures Manual) guidelines for when TSARA cases are required.

QUESTIONS REGARDING THIS BULLETIN

Technical inquiries	Contact the BMW Technical Support Group via TSARA
Warranty inquiries	Submit an IDS ticket to the Warranty Department
Parts inquiries	Submit an IDS ticket to the Motorrad Parts Department

Supporting Materials

[picture_as_pdf 33 01 24 SERVICE SOLUTION - Chassis Calibration.pdf](#)

