

February 18, 2025

Version 2

Rear Differential Pump Motor Connector Corrosion Sets AWD DTCs

Supersedes 24-022 dated November 22, 2024, to revise the information highlighted in **yellow**.

APPLIES TO

Year	Model	Trim Level	VIN Range
2015-20	TLX AWD	ALL	ALL
2016-20	MDX AWD Non-Hybrid	ALL	ALL

REVISION SUMMARY

Under PARTS INFORMATION, a part has been added.

SYMPTOM

The AWD warning light is on. One or more AWD DTCs have been set.

Some common DTCs:

C1841-27: Differential temperature sensor 1 circuit

C1842-27: Differential temperature sensor 2 circuit

C1850-12: Right side pressure sensor circuit high voltage

C1851-87: F-CAN malfunction lost communication

C1851-96: Functional abnormalities of differential fluid pump

C1855-92: Differential motor low speed

POSSIBLE CAUSE

Water intrusion into the electric oil pump motor connector area corrodes the terminals.

CORRECTIVE ACTION

If the DTCs listed in SYMPTOM are present, replace the rear differential pump motor and rear subframe subharness.

CLIENT INFORMATION: The information in this bulletin is intended for use only by skilled technicians who have the proper tools, equipment, and training to correctly and safely maintain your vehicle. These procedures should not be attempted by "do-it-yourselfers," and you should not assume this bulletin applies to your vehicle, or that your vehicle has the condition described. To determine whether this information applies, contact an authorized Acura automobile dealer.

WARRANTY CLAIM INFORMATION

Operation Number	Description	Flat Rate Time	Defect Code	Symptom Code	Template ID	Failed Part Number
2191CN	2016 MDX: Replace the rear differential pump motor and subharness (includes Maintenance Minder reset & DTC clear)	0.7 hr	06401	03217	B24022A	48900-5M0-003
2191CN	2017–20 MDX: Replace the rear differential pump motor and subharness (includes Maintenance Minder reset & DTC clear)	0.7 hr	06401	03217	B24022B	48900-5M0-003
2191CN	2015–17 TLX: Replace the rear differential pump motor and subharness (includes Maintenance Minder reset & DTC clear)	0.7 hr	06401	03217	B24022C	48900-5M0-003
2191CN	2018–20 TLX: Replace the rear differential pump motor and subharness (includes Maintenance Minder reset & DTC clear)	0.7 hr	06401	03217	B24022D	48900-5M0-003
2191CN	2019–20 MDX Advance: Replace the rear differential pump motor and subharness (includes Maintenance Minder reset & DTC clear)	0.7 hr	06401	03217	B24022E	48900-5M0-003

PARTS INFORMATION

MDX

Part Name	Part Number	Quantity
2016: Rear Subframe Subharness	32114-TZ6-A01	1
2017-20: Rear Subframe Subharness	32114-TZ6-A02	1
2019-20 Advance: Rear Subframe Harness	32114-TYS-A10	1

TLX

Part Name	Part Number	Quantity
2015-17 Rear Subframe Subharness	48320-5M0-020	1
2018-20: Rear Subframe Subharness	48320-5M0-A00	1

All Models

Part Name	Part Number	Quantity
Rear Differential Pump Motor	48900-5M0-013	1
Drain Plug Washer (18 mm)	90471-PX4-000	1
Drain Plug Washer (20 mm)	94109-20000	1

REQUIRED MATERIALS

Part Name	Part Number	Quantity
Acura All-Wheel Drive Fluid (DPSF)	08200-9007A	2 US qt

INSPECTION PROCEDURE

1. Put the vehicle on a lift and position the lift pads under the vehicle's front support points and rear support points.
 - 2015–20 TLX - [Lift and Support Points](#)
 - 2016–20 MDX - [Lift and Support Points](#)
2. Inspect the connectors at C125 (Rear Subframe Harness to Rear Differential Pump Motor) for signs of water intrusion or corrosion.

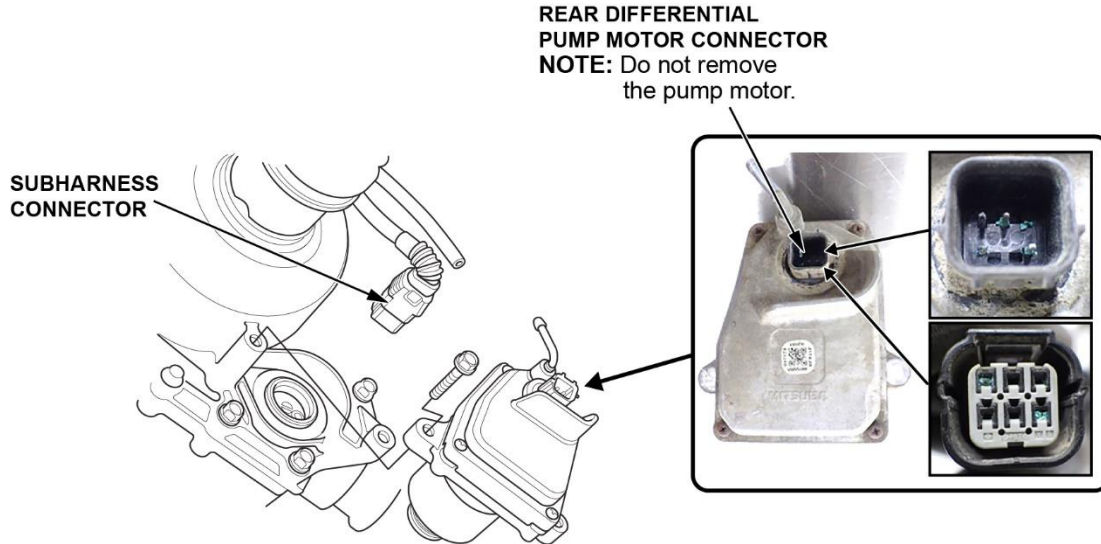

Do either of the connectors have any signs of water intrusion or corrosion?

YES - Go to the REPAIR PROCEDURE.

NO - This service bulletin does not apply. Continue with normal troubleshooting.

REPAIR PROCEDURE

1. Drain the rear differential by removing the filler plug and sealing washer, then remove the drain plug and sealing washer.
2. Disconnect the breather hose (rear differential pump motor side).

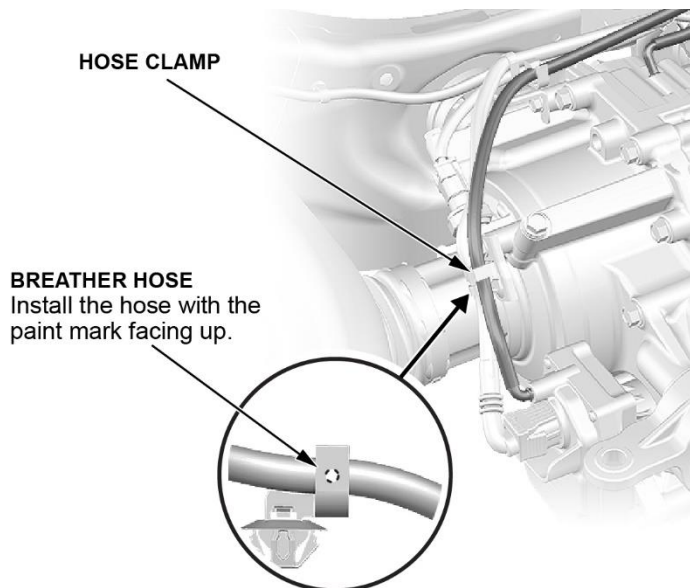

3. Remove the pump motor and the O-ring.

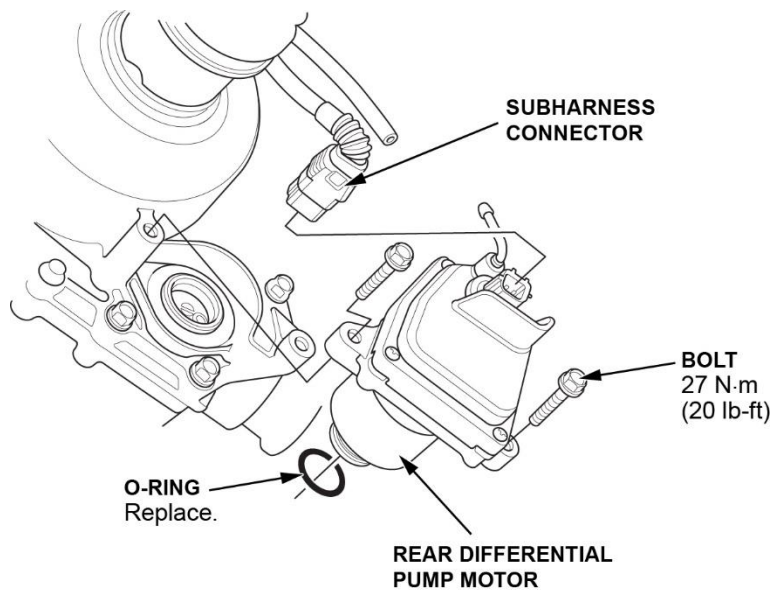

4. Remove the existing rear subframe subharness and install the new one.
5. Install the new oil pump motor assembly and rear subframe wire harness.
6. Install the drain plug with a new sealing washer.
7. Fill the rear differential fluid.

Fluid Capacity: 1.82L (1.92 US qt)

Recommended fluid: Acura All-Wheel Drive Fluid (DPSF)

8. Loosely install the filler plug with the used sealing washer.
9. Do the rear differential fluid air bleeding:
 - Shift the transmission to PARK position/mode.
 - Start the engine.
 - Wait for **1 minute**.
10. Turn the ignition OFF.
11. Remove the filler plug and the sealing washer.

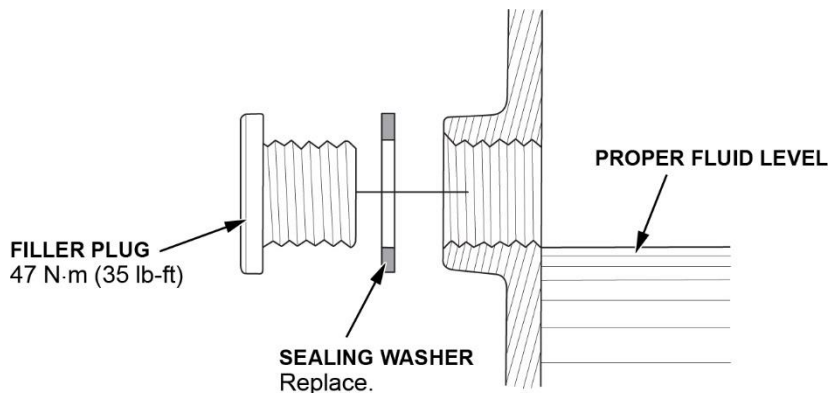

12. Check and fill the rear differential with rear differential fluid to the proper level.
13. Install the filler plug with a new sealing washer.
14. Reset the Maintenance Minder sub-item number 6 (Replace Rear Differential Fluid). Refer to the Maintenance Minder General Information for the appropriate model for more information.
 - 2015–20 TLX – [Maintenance Minder General Information](#)
 - 2016–20 MDX – [Maintenance Minder General Information](#)