

**February 19, 2025**

Version 6

**Warranty Extension: 2016-20 HR-V CVT Premature Belt Deterioration**Supersedes 21-047, Dated April 29, 2023, to revise the information highlighted in **yellow**.**APPLIES TO**

Year	Model	Trim	VIN Range
2016–20	HR-V 2WD & AWD (CVT models only)	ALL	Check the iN VIN status for eligibility.

**REVISION SUMMARY**Under **INSPECTION PROCEDURE AND CONFIRMATION OF FAILED CVT**, information was changed.**BACKGROUND**

Due to the possibility of early deterioration of the Continuous Variable Transmission (CVT) drive belt, American Honda is extending the warranty coverage on these CVT models to 7 years from the original date of purchase or 150,000 miles, whichever comes first. If the PCM software was previously updated in service bulletin 21-046, *Product Update: 2016-20 HR-V Software Update and CVT Inspection*, the warranty extension applies, since the CVT primary drive belt is now a OBD-monitored part due to the addition of DTC P271E.

**CUSTOMER NOTIFICATION**

Owners of affected vehicles will be sent a notification of this campaign.

Do an iN VIN status inquiry to make sure the vehicle is shown as eligible.

Some vehicles affected by this campaign may be in your new or used vehicle inventory. Repair these vehicles before they are sold.

**CORRECTIVE ACTION**

Replace the Continuously Variable Transmission (CVT).

NOTE: Update the Continuously Variable Transmission (CVT) PCM software, and do the CVT inspection before doing this repair. Refer to service bulletin 21-046, *Product Update: 2016-20 HR-V Software Update and CVT Inspection*.**PARTS INFORMATION**

Part Name	Part Number	Quantity
Transmission Assembly	06200-52P-A02RM	1
Transmission Assembly	06200-52N-A04RM	1
Transmission Assembly	06200-52P-A70RM	1

**CUSTOMER INFORMATION:** The information in this bulletin is intended for use only by skilled technicians who have the proper tools, equipment, and training to correctly and safely maintain your vehicle. These procedures should not be attempted by “do-it-yourselfers,” and you should not assume this bulletin applies to your vehicle, or that your vehicle has the condition described. To determine whether this information applies, contact an authorized Honda automobile dealer.

NOTE: After the vehicle was updated and if the CVT failed the magnet inspection in service bulletin 21-046, *Product Update: 2016-20 HR-V Software Update and CVT Inspection*, to order a replacement transmission fill out **AT/CVT Order** form under **Reman Parts/Special Orders** section on iN. You will need to have the following information:

- Provide a clear picture of the magnet sticking on the CVT oil pan at the inspection area (this picture should have been taken during the CVT magnet inspection). Also, write the last seven characters of the VIN on the transmission oil pan.

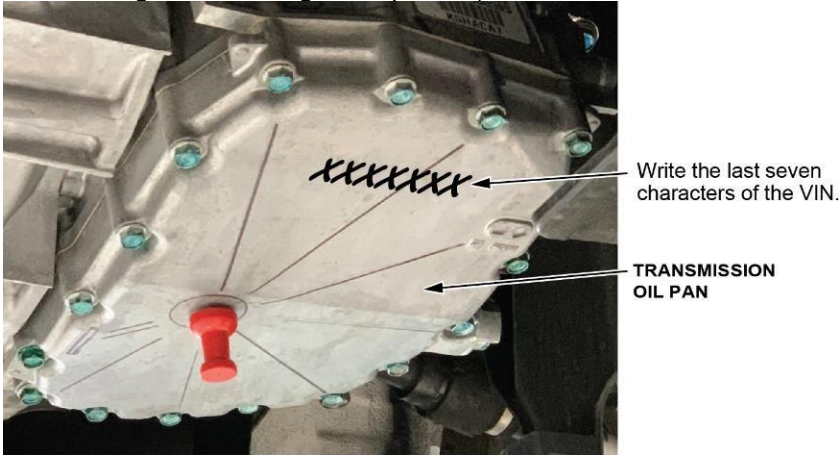

- Drain the CVT fluid through a paint strainer as shown below. Provide a clear picture of the inside of the strainer showing any contamination.



- Provide a clear picture of any contaminants on the end of the oil pan drain plug.



- Upload the three images to the Tech Line Image Upload page before submitting the CVT order form on iN. If you have not contacted Tech Line then use the last 7 digits of the VIN for the Tech Line Reference No.
- If the 11<sup>th</sup> character of the VIN has a letter instead of a number, replace it with a zero.
- Select Tech Line Agent Name –Tech\_Line .

Last seven characters of the VIN. Enter last seven characters of the VIN to Tech Line Reference Number. If the first character is a "letter", replace it with a "0".

- Fill out the **AT/CVT Order** form under **Reman Parts/Special Orders** section on iN. If the vehicle is beyond the 5 year / 60,000 mile warranty term use 21047 as the Goodwill VSC Authorization. This will allow the order to be processed under the Extended warranty coverage, then continue filling out the remaining required information on the form.

- Once the CVT order & three images have been received, your order will be reviewed by Remanufactured Parts Operations (RPO). Additional requests and images may be required by RPO before release of the CVT.

**REQUIRED MATERIALS**

Materials	Part Number	Quantity
Honda HCF-2 Continuously Variable Transmission Fluid (55-gallon drum)	08200-9020	8 quarts (AWD)
Honda HCF-2 Continuously Variable Transmission Fluid (1-quart bottle)	08200-HCF2	7 quarts (FWD)
Disposable Paint Strainer (pack of 250) or Commercially equivalent (fixes 250 vehicles)	PMICSM6	1

**WARRANTY CLAIM INFORMATION**

Powertrain and Emissions Warranty Coverage Inquiry				
Identification VAT0031				
Inquiry Information				
VIN	Customer State CA - California			
Description HR-V 5DR 2WD EX	Year 2016	Model RU5H5GJW	Emission Type KA	
Item	Part Number	Description	Powertrain Warranty (Months/Miles)	Emission Warranty (Months/Miles)
1	20031-52P-A02	TRANSMISSION (DOT)	60/ 60,000	96/ 80,000

NOTE: Check the powertrain and emissions table on the iN to verify the applicable coverage.

**Powertrain Coverage**

NOTE: If within 5 years/60,000 miles, use the operation number below.

Operation Number	Description	Flat Rate Time	Defect Code	Symptom Code	Failed Part Number
218102	Transmission and torque converter exchange	5.0 hr	00504	03217	20031-52N-A02
A	With AWD add	0.4 hr			
B	Alignment add	0.4 hr			

### Emissions Coverage

NOTE: If **between 5 years/60,000** and **8 years/80,000 miles**, use the **operation number** below.

Operation Number	Description	Flat Rate Time	Defect Code	Symptom Code	Template ID	Failed Part Number
2181CU	2016-20 2WD Replace Transmission 8/80 Emissions Warranty (Includes DTC clear, alignment & VSA sensor learn)	5.4 hr.	00504	03214	A21047A	20031-52N-A02
	2016-18 AWD Replace Transmission 8/80 Emissions Warranty (Includes DTC clear, alignment & VSA sensor learn)	5.8 hr.			A21047B	20031-52P-A02
	2019-20 AWD Replace Transmission 8/80 Emissions Warranty (Includes DTC clear, alignment & VSA sensor learn)				A21047C	20031-52P-A70

### Warranty Extension Coverage

NOTE: If **between 5 years/80,000** and **7 years/150,000 miles**, use the **operation number** below.

Operation Number	Description	Flat Rate Time	Defect Code	Symptom Code	Template ID	Failed Part Number
2181CT	2016-20 2WD Replace Transmission 7/150 Warranty Extension (Includes DTC clear, alignment & VSA sensor learn)	5.4 hr.	6M900	JAT00	A21047D	20031-52N-A02
	2016-18 AWD Replace Transmission 7/150 Warranty Extension (Includes DTC clear, alignment & VSA sensor learn)	5.8 hr.			A21047E	20031-52P-A02
	2019-20 AWD Replace Transmission 7/150 Warranty Extension (Includes DTC clear, alignment & VSA sensor learn)				A21047F	20031-52P-A70

Skill Level: Repair Technician

## INSPECTION PROCEDURE AND CONFIRMATION OF FAILED CVT

The transmission inspection utilizes a special magnet to detect any metal fragments that may have been shed from the CVT belt. These fragments will collect in the oil pan. The inspection is done by placing a clear template on the CVT oil pan. Refer to service bulletin 21-046, *Product Update: 2016-20 HR-V Software Update and CVT Inspection*.

If the PCM was updated and the CVT failed the magnet inspection on service bulletin 21-046, *Product Update: 2016-20 HR-V Software Update and CVT Inspection*, place an RPO order on SIS for a replacement transmission. You will need to have the following information:

- Provide a clear picture of the magnet sticking on the CVT oil pan at the inspection area (this picture should have been taken during the CVT magnet inspection).
- Drain the CVT fluid through a paint strainer as shown below. Provide a clear picture of the inside of the strainer showing any contamination.
- Provide a clear picture of the magnet on the end of the oil pan drain plug.
- If you encounter a situation where the magnet sticks but you do not find any metal on the drain plug or inside the strainer, you may be instructed to perform additional confirmation steps by RPO.

## REPAIR PROCEDURE

1. Remove wiper arms and cowl cover.

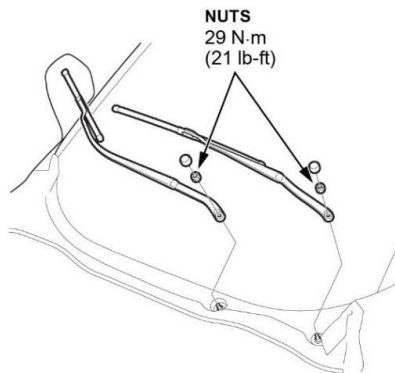

2. Remove the left and right front fender covers.

FRONT FENDER COVER

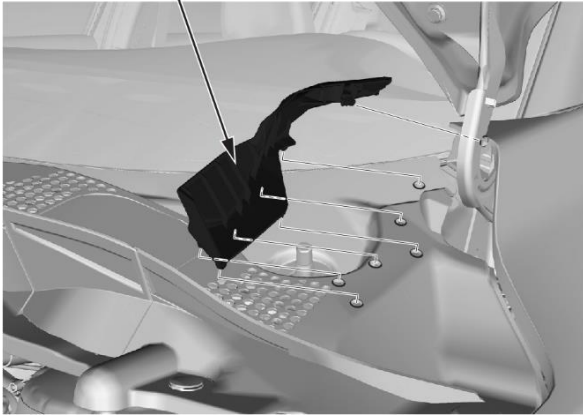

3. Remove the hood rear seal.

HOOD REAR SEAL



4. Remove the cowl cover.

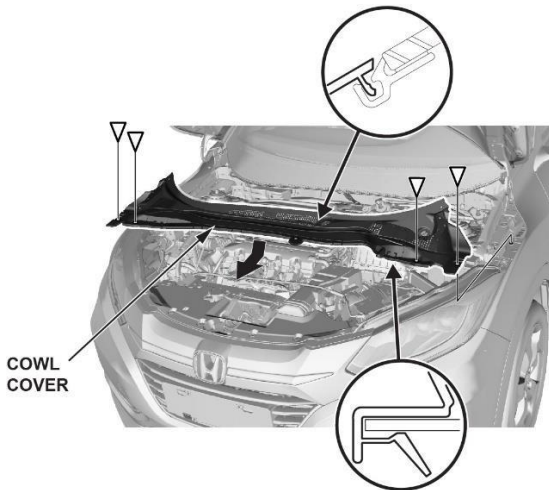

5. Remove the dashboard upper lid.

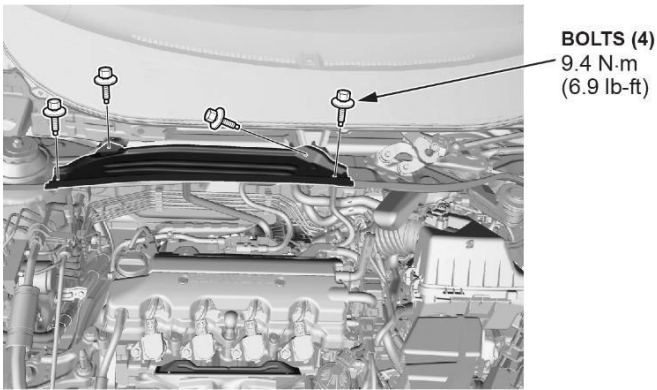

6. If necessary, remove the dashboard upper lid insulator.

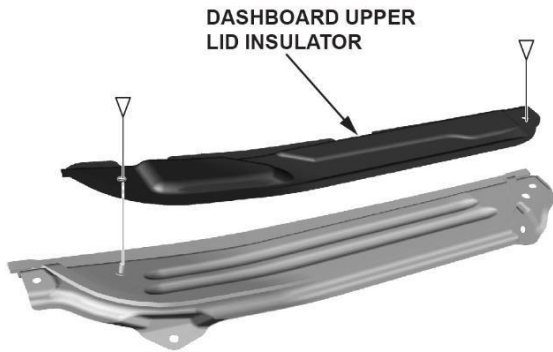

7. Remove the front grille cover.

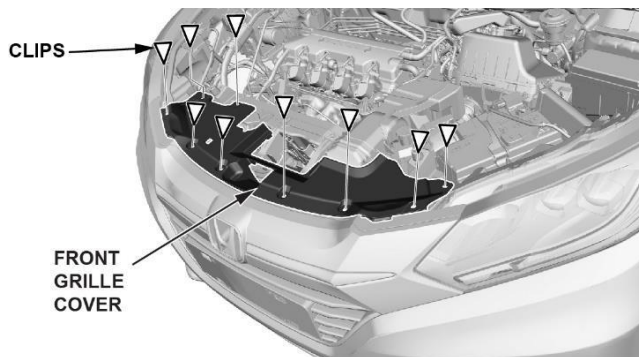

8. Remove the air intake duct.

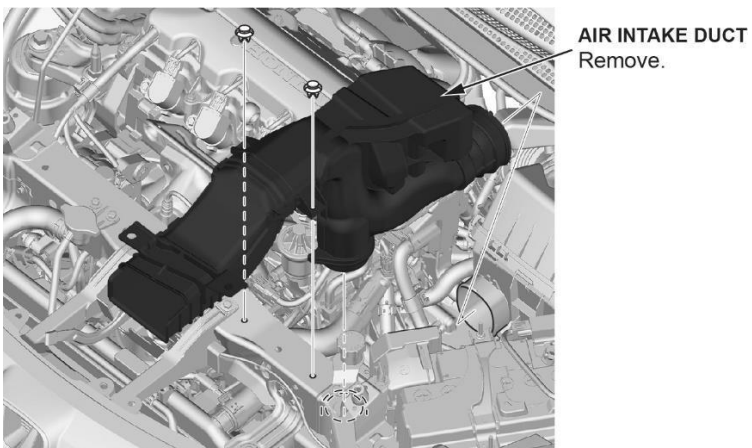

9. Remove the air cleaner.

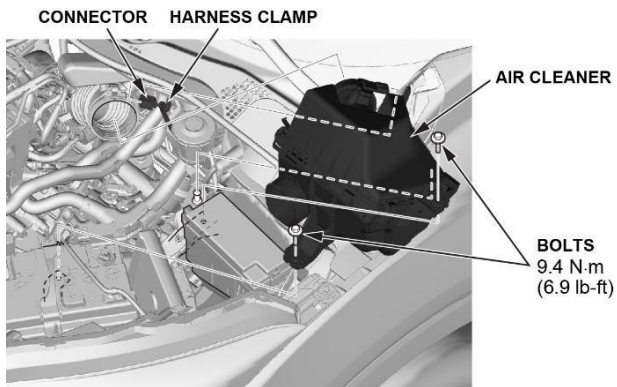

10. Disconnect and remove the 12-volt battery. Refer to the service information.

11. Remove the bolts and disconnect the connectors.

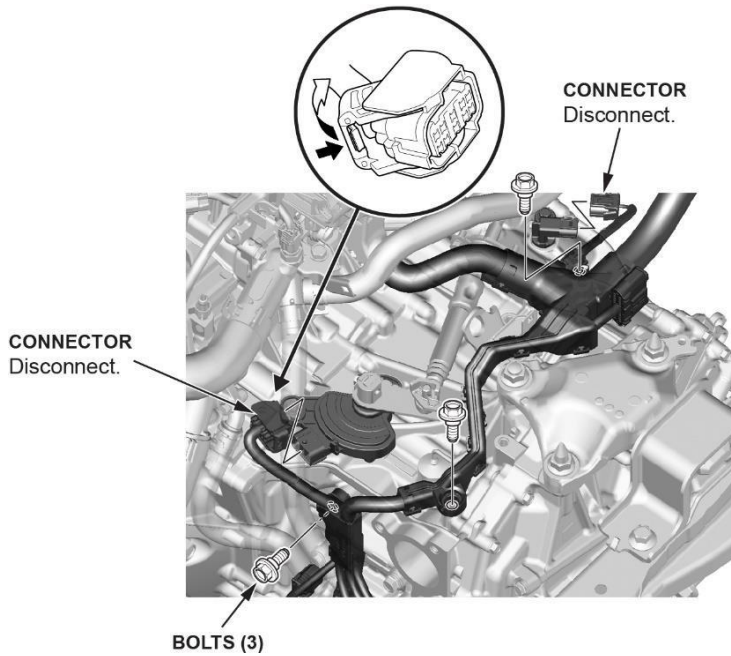

12. Remove the lock pin, control pin, shift cable bracket, shift cable, and engine wire harness.

NOTE: Do not bend the shift cable excessively.

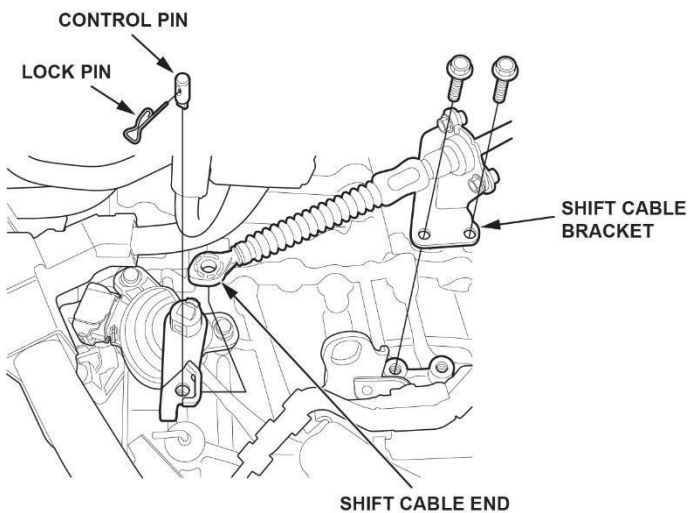

13. Remove the engine cover, harness cover bolts, harness bracket, harness holder, disconnect the connectors.

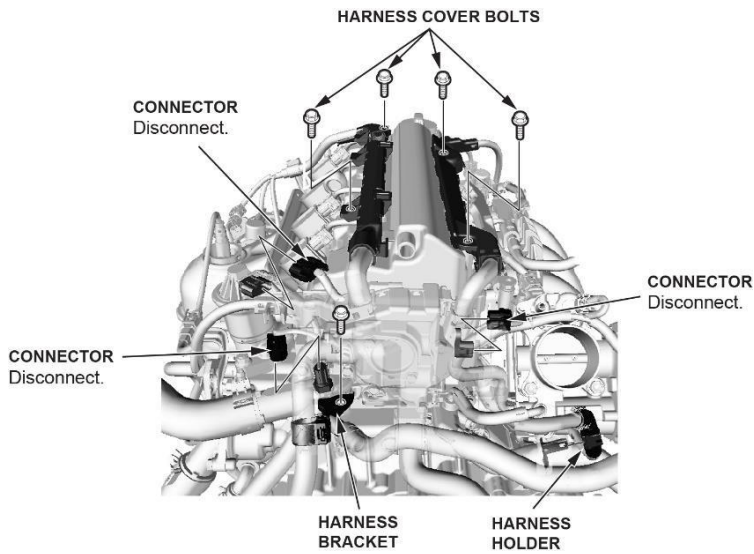

14. Remove the bolts, clamps, and move the harness holder, then remove the bracket.

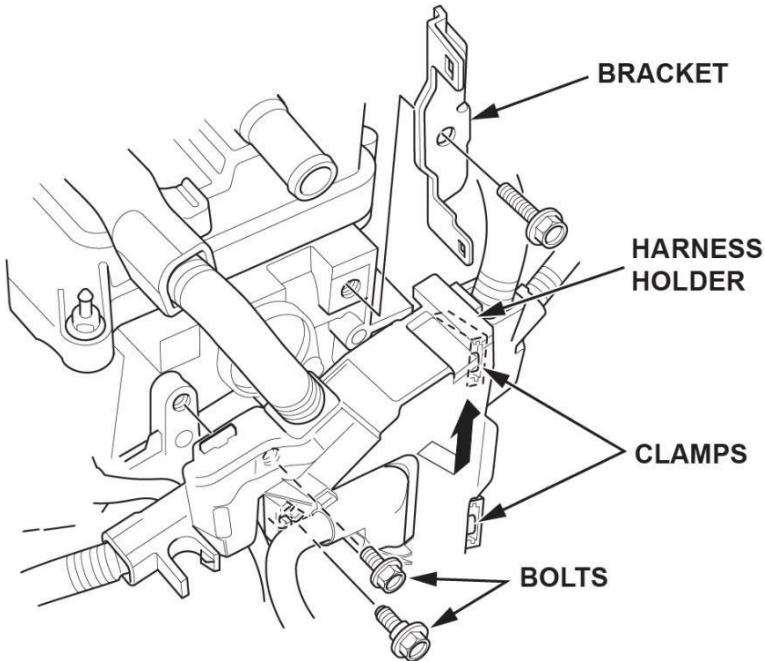

15. Attach the universal lifting eyelet to the cylinder head.

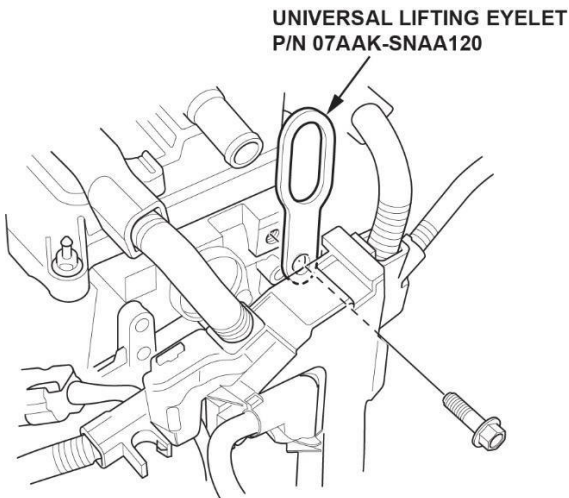

16. Install the engine support hanger, then attach the hook to the slotted hole in the universal lifting eyelet. Tighten the wing nut by hand and support the engine/transmission.

NOTE: Be careful when working around the windshield.

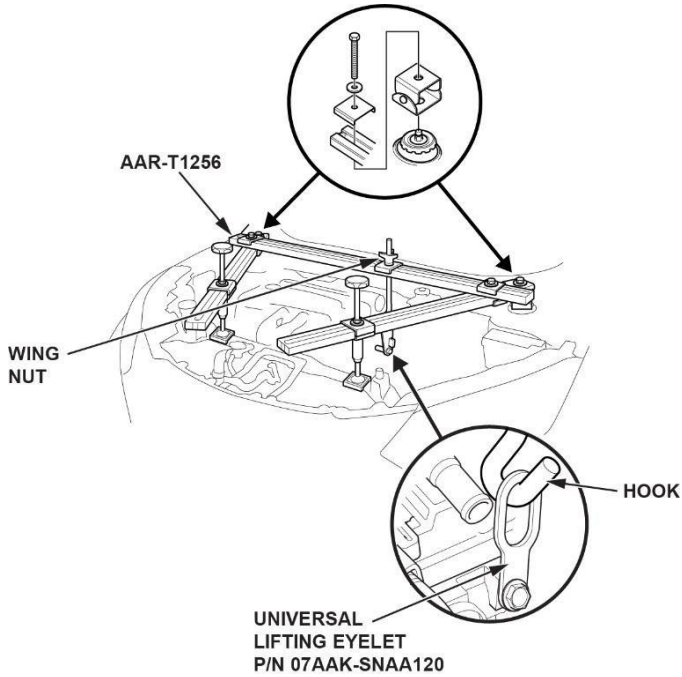

17. Remove the ground cable and the transmission mount.

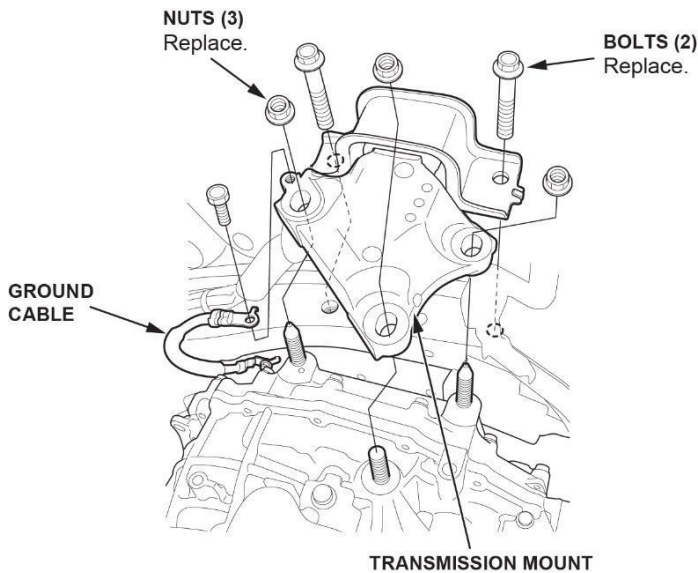

18. Raise up the vehicle and drain the transmission fluid. Refer to the service information.

19. Remove the front wheels. Refer to the service information.

20. Set the steering column to the center tilt position and to the center telescopic position. Center the steering wheel spoke angle and install a steering wheel holder.

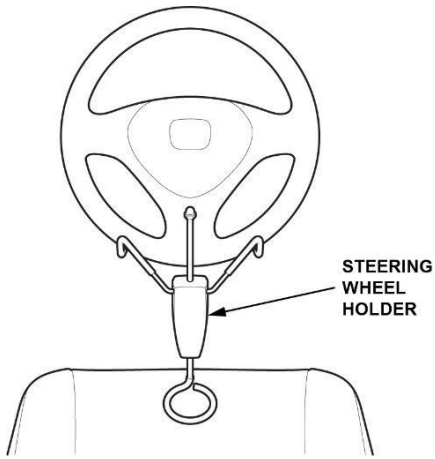

21. Remove the steering joint cover.

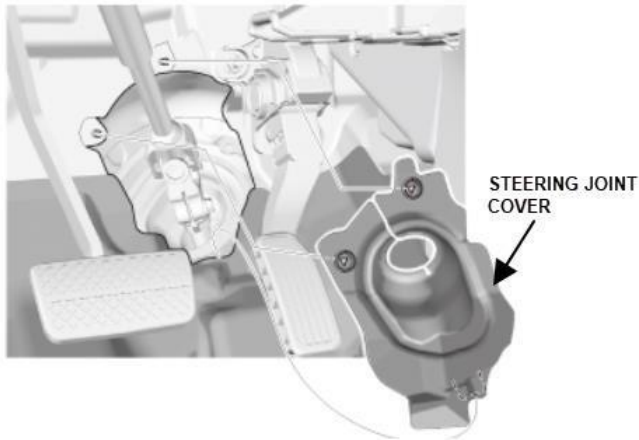

22. Hold the spline shaft on the column with a piece of wire between the joint yoke of the spline and the joint yoke of the spline tube to prevent the lower spline shaft from coming out.

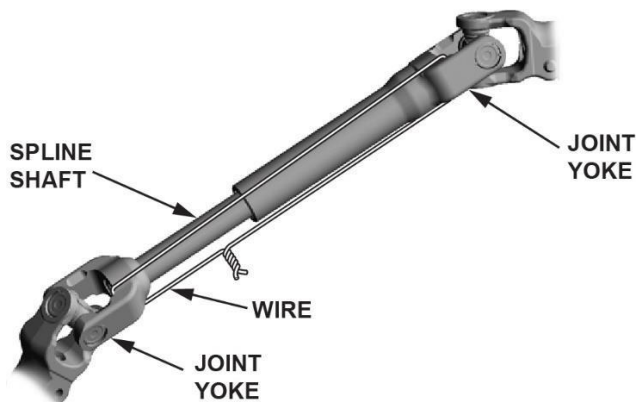

23. Remove the steering joint bolt.

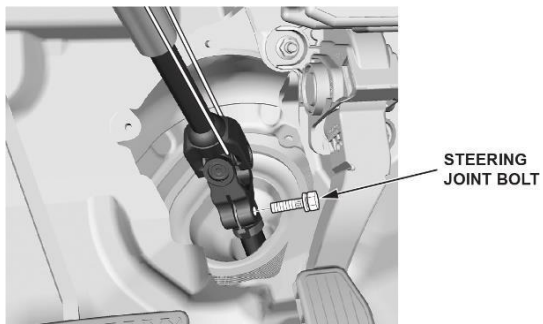

24. Disconnect the steering joint from the pinion shaft.

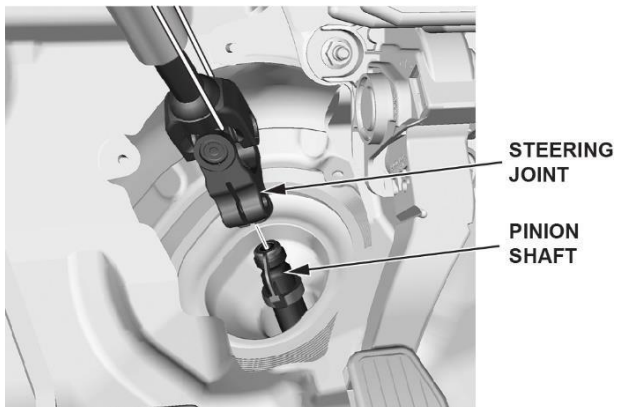

25. Remove the center guide (if equipped) and discard it.

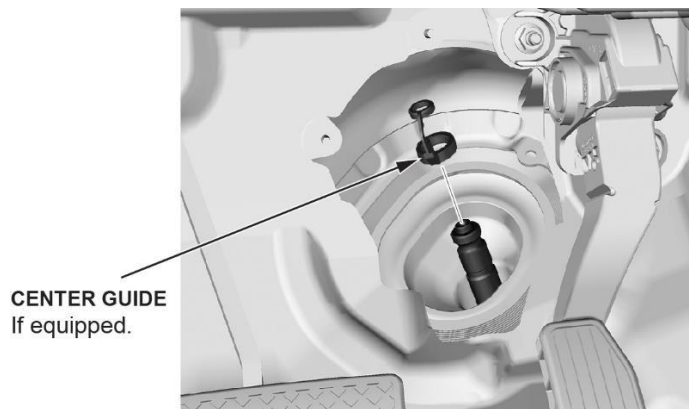

26. Remove the flange bolt and self-locking nuts, then disconnect the lower arm from the lower arm ball joint.

NOTE:

- Use new self-locking nuts and flange bolt during reassembly.
- Tighten the self-locking nuts and the flange bolt in the sequence shown.

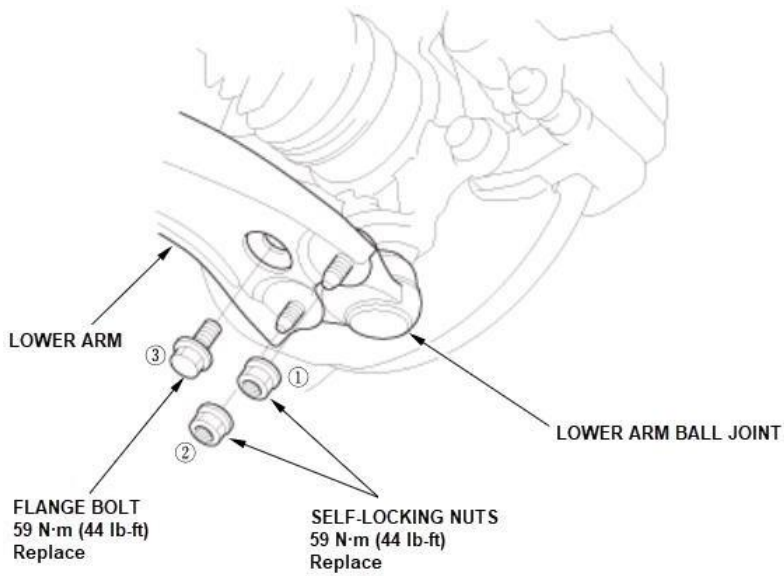

27. Remove the self-locking nut and the flange nut while holding the joint pin with a hex wrench and remove the stabilizer link.

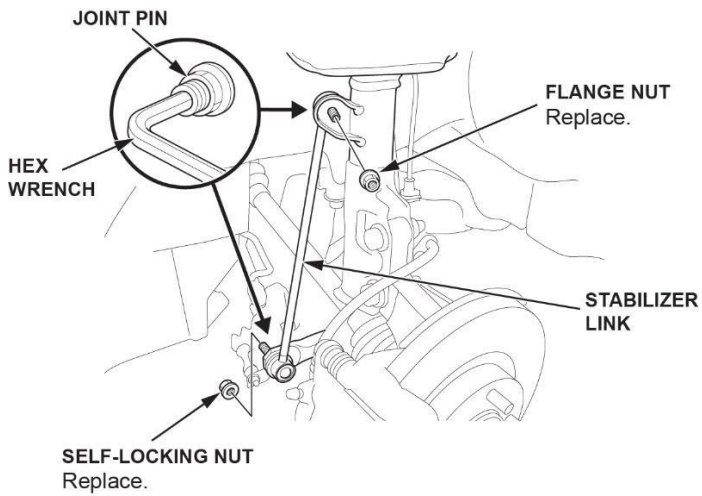

28. Disconnect the connector and remove the secondary HO2S.

**SECONDARY HO2S**  
45 N·m (33 lb-ft)

**CONNECTOR**

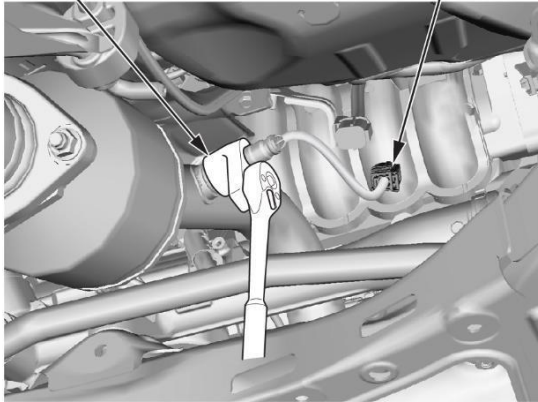

29. Remove the under-floor TWC and the gaskets.

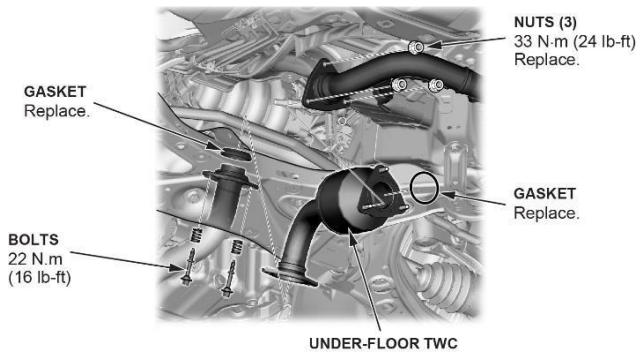

30. Lift and support the engine with a transmission jack and a wood block under the oil pan and remove the torque rod.

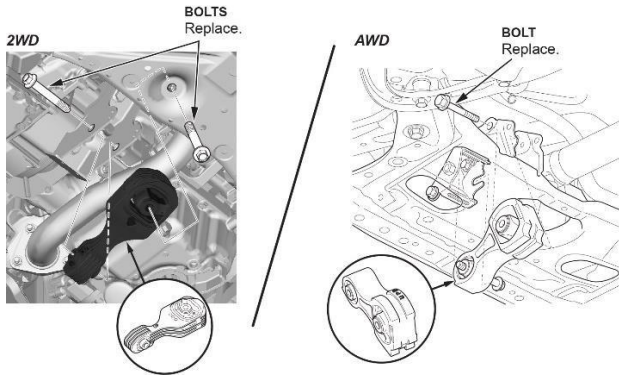

31. Remove the torque rod bracket as needed.

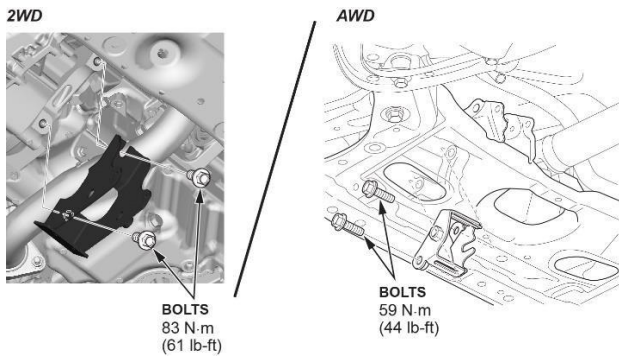

32. Attach a wood block (A) to the lower center of the front subframe, attach a transmission jack (C) to the center of the wood block. Support the front subframe securely by raising the transmission jack, remove the front subframe mounting bolts (D) and the subframe rear stay mounting bolts (E).

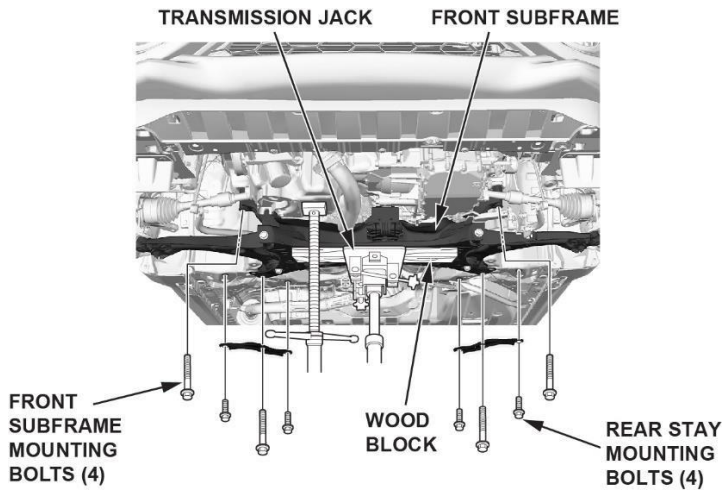

33. Lower the jack slowly until the subframe of the body has dropped about **30 mm**.

NOTE: Do not lower the subframe more than required.

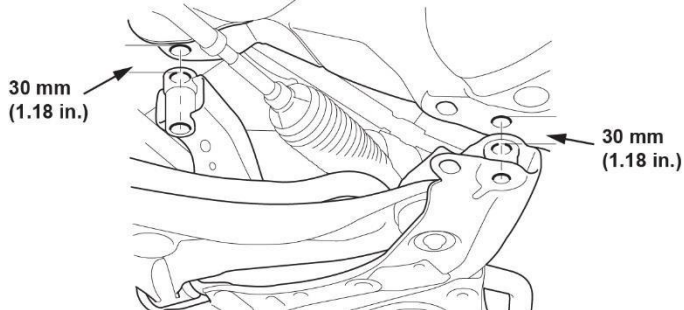

34. Remove the steering gearbox stays and remove the gearbox washer.

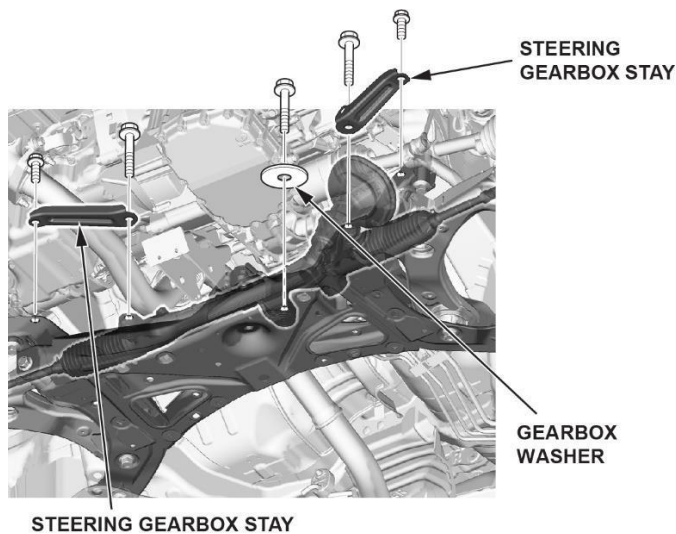

35. Remove the pinion shaft grommet.

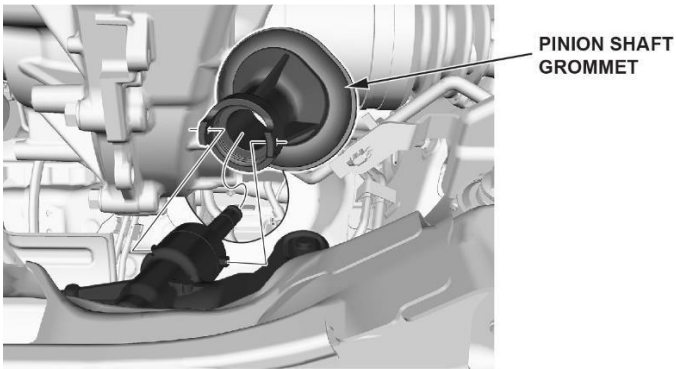

36. Disconnect the connectors and remove the harness clamp.

NOTE: To prevent damage, cover the solenoid wire harness connector using a shop towel.

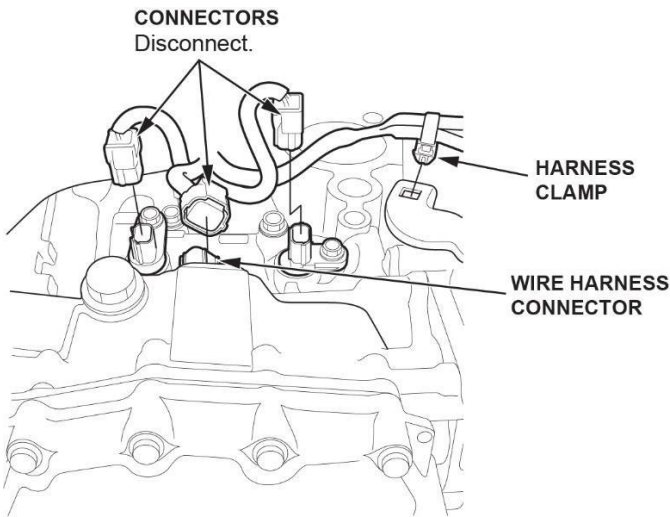

37. Disconnect the connector.

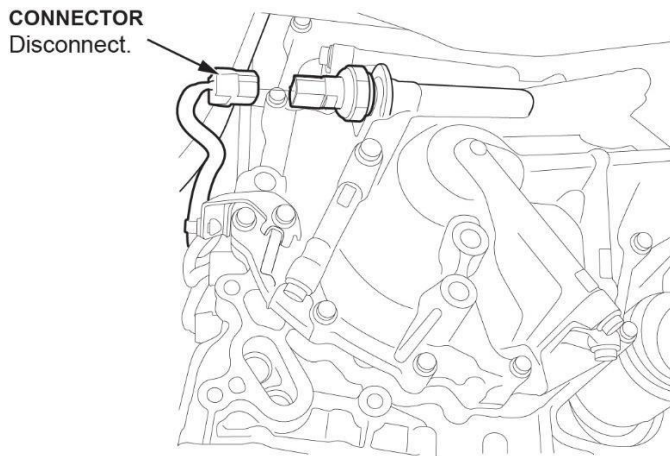

For 2WD models, go to step 46.

For AWD models, continue to the next step.

38. Remove the front floor undercover.

NOTE: The retainer clips stay in the front floor under cover.

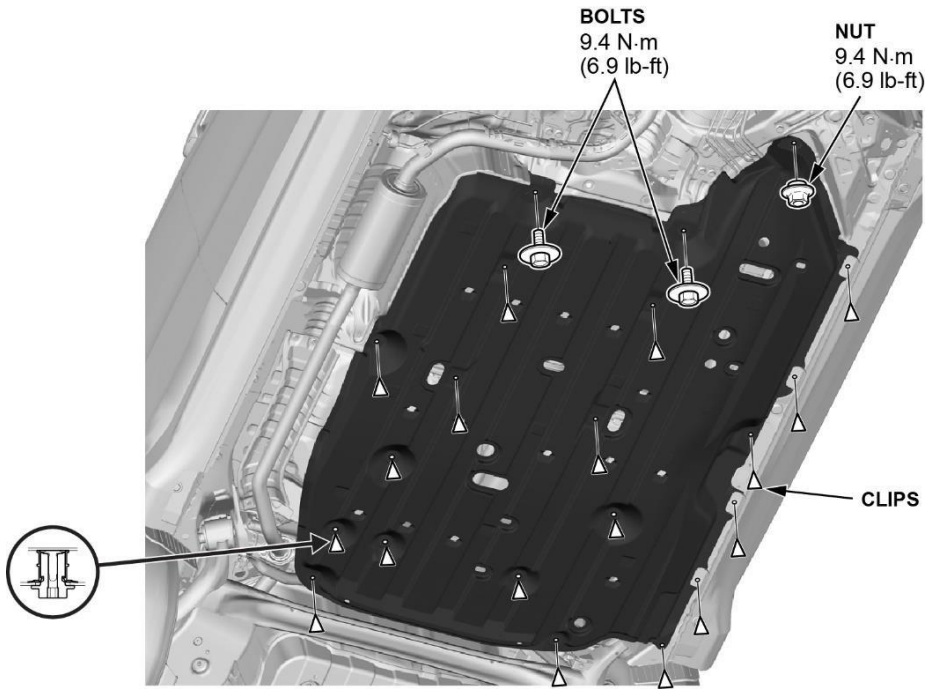

39. Remove the front fuel tank guard.

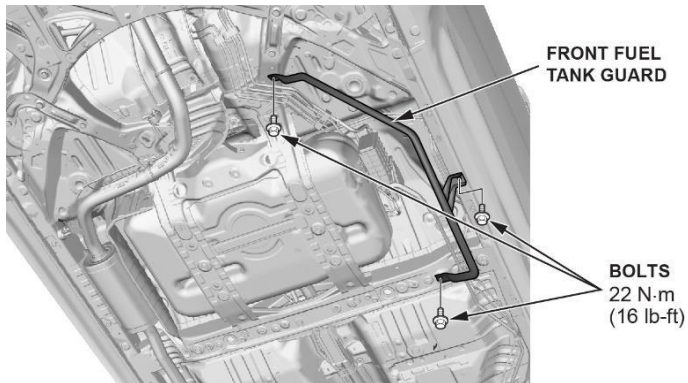

40. Remove the canister guard.

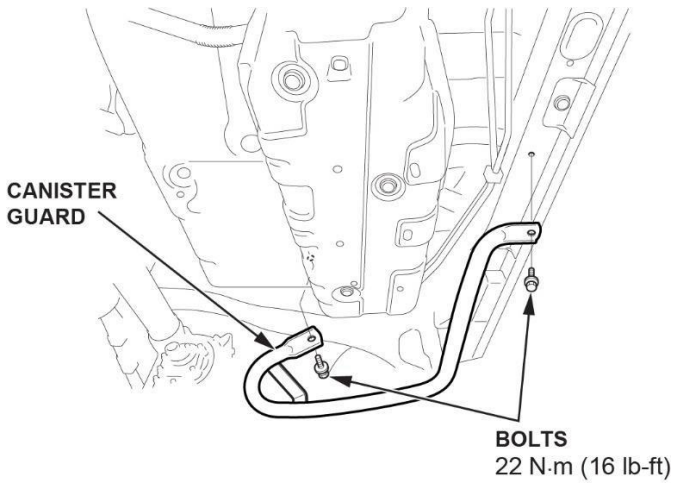

41. Remove the front center member.

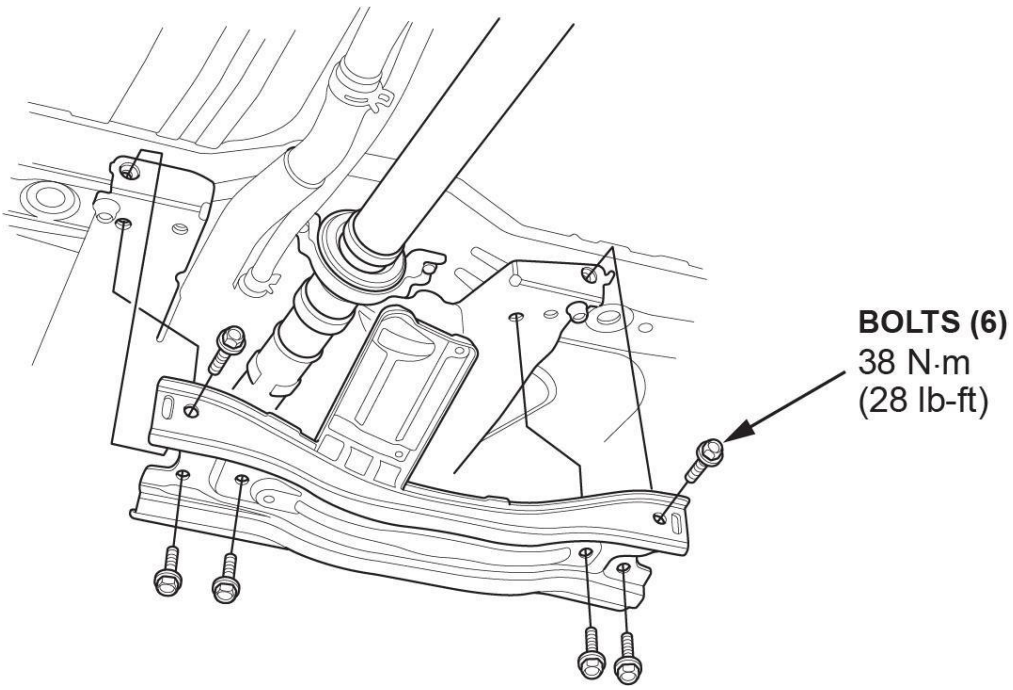

42. Remove the propeller shaft protector.

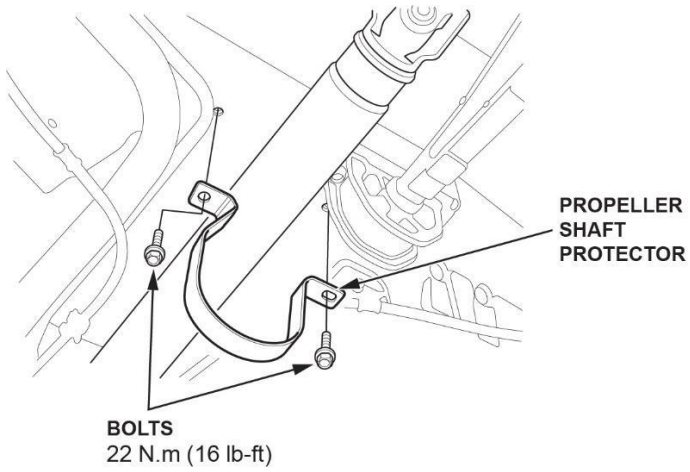

43. Make a reference mark across the No. 1 propeller shaft, transfer the companion flange, then remove the No. 1 propeller shaft flange bolts.

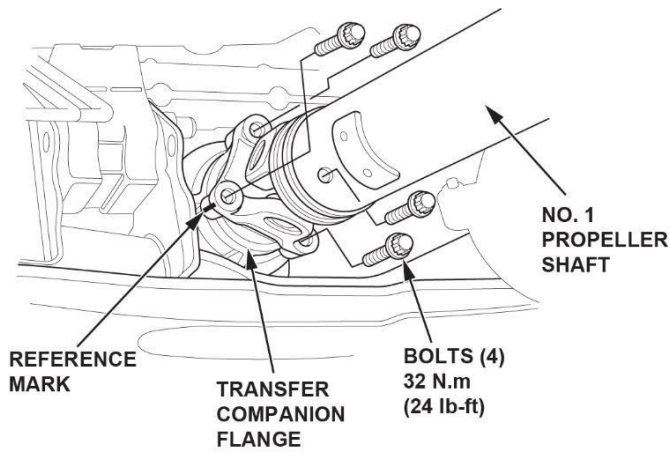

44. Make a reference mark across the No. 2 propeller shaft, the rear differential companion flange, then remove the No. 2 propeller shaft flange bolts.

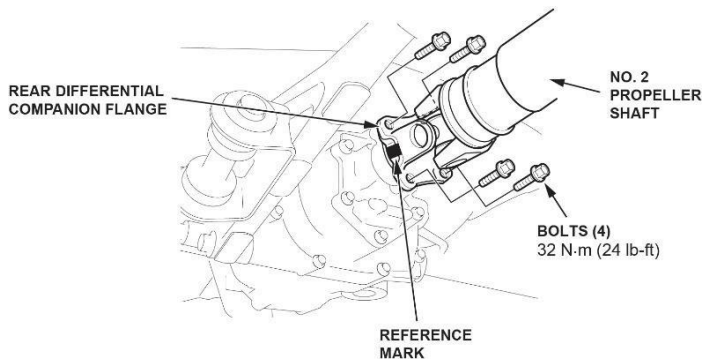

45. Remove the center support bearing mounting bolts.

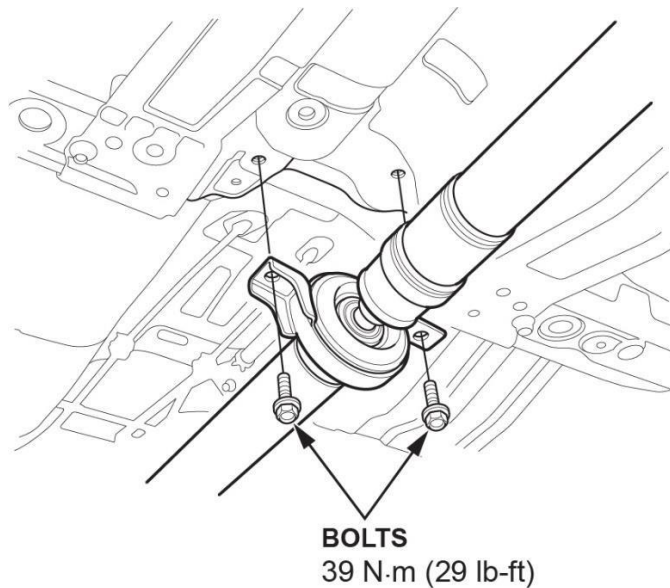

46. Remove the torque converter cover.

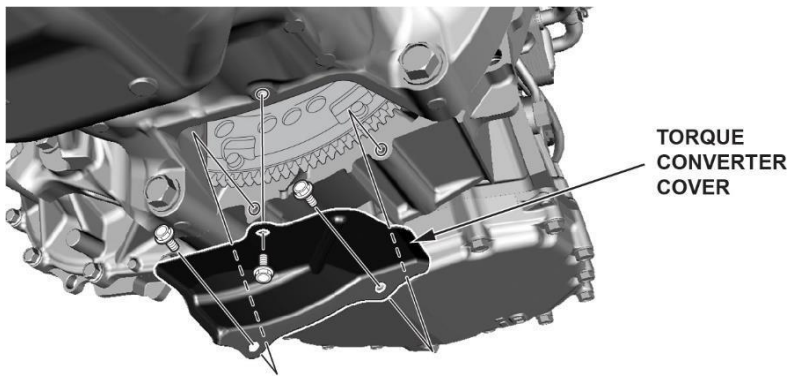

47. Remove the 8 torque converter bolts.

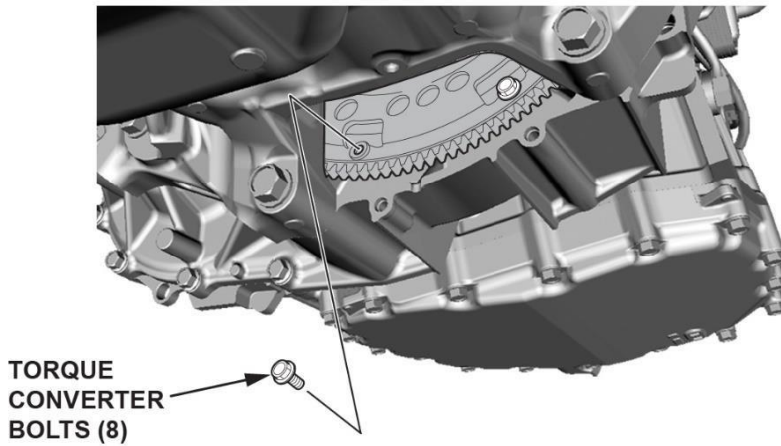

48. Disconnect the left driveshaft inboard joint and secure the driveshafts to the body with straps.

**LEFT DRIVESHAFT**

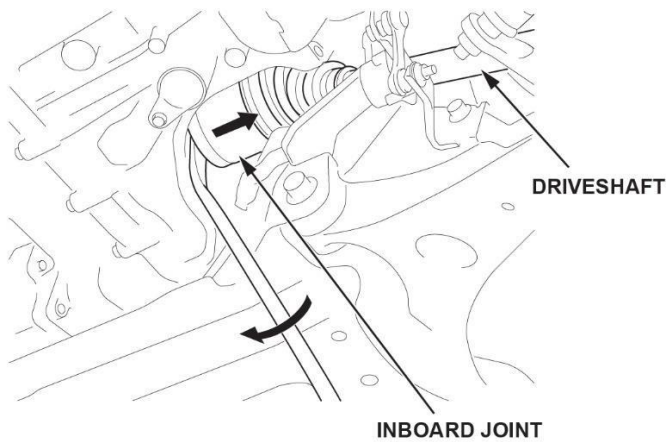

49. Disconnect the right driveshaft inboard joint and secure the driveshaft to the body with straps.

**RIGHT DRIVESHAFT**

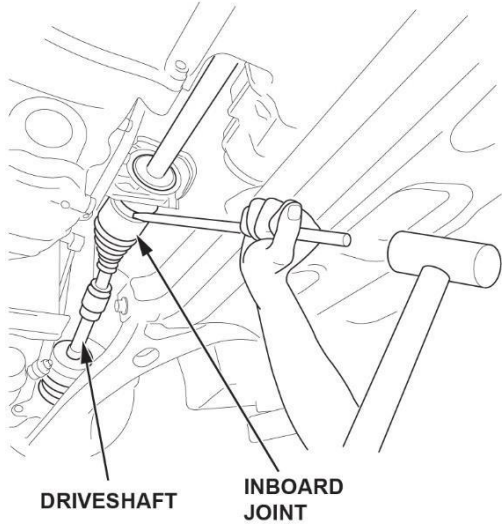

50. Remove the intermediate shaft bolts.

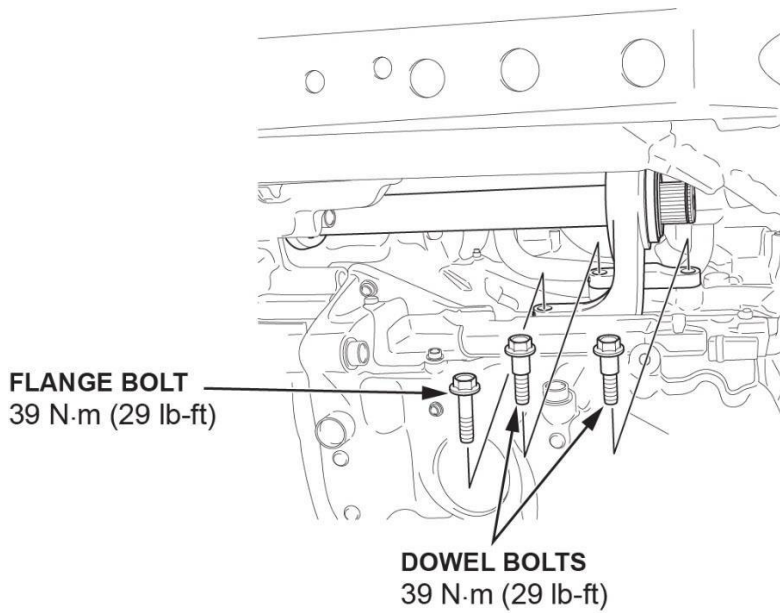

51. Remove the intermediate shaft.

NOTE: Hold the intermediate shaft horizontal until it is clear of the differential to prevent damaging the oil seal.

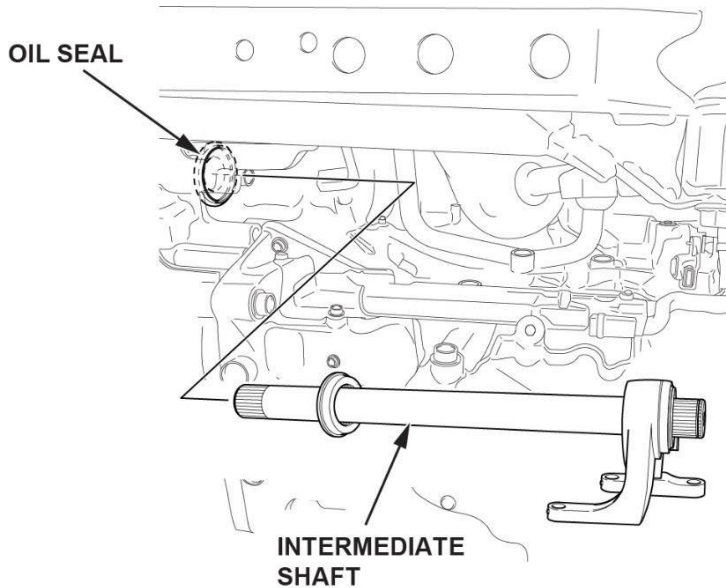

52. Check that the transmission is free of hoses and electrical wiring, lower the transmission by loosening the wing nut of the engine support hanger and tilt the engine just enough for the transmission to clear its end from the side frame. Slide the transmission away from the engine, then remove the transmission from the vehicle.

NOTE: Be careful not to drop the torque converter.

53. Install the new CVT with the new torque converter installed.

NOTE: It is very important to use the new transmission warmer that comes with the CVT instead of re-using the old one to avoid contaminating the new CVT.

54. Install all removed parts in the reverse order of removal.

55. Fill the CVT with fluid. Refer to the service information.

56. Do a wheel alignment. Refer to the service information.

57. Do a VSA sensor neutral position memorization.