

Technical Service Bulletin

Mazda North American Operations
Irvine, CA 92618-2922



| | |
|--|---------------------------------|
| Subject: DRIVER'S SIDE OUTER MIRROR GLASS VIBRATES WHEN DRIVING AT HIGH SPEED ON BUMPY ROAD | Bulletin No.: 09-011/25 |
| | Last Issued : 02/24/2025 |

BULLETIN NOTES

This bulletin supersedes the previously issued bulletin(s) listed below. The changes are noted in Red.

| Previous TSBs: | Date(s) Issued: |
|----------------|-----------------------|
| 09-018/24 | 08/21/24 and 03/22/24 |

APPLICABLE MODEL(S)/VINS

2024-2025 CX-90 (with auto-dimming mirror)

2025 CX-70 (with auto-dimming mirror)

DESCRIPTION

Some customers may complain that the driver's side outer mirror glass vibrates when driving at high speeds at approximately 60 mph (100 km/hour) or more on bumpy roads such as road joints, coarse-grained paved roads or rough roads. This is caused by insufficient hardness of the adhesive tape between the outer mirror glass holder and the mirror glass. To eliminate this concern, the material of the adhesive tape between the outer mirror glass holder and the mirror glass has been improved and the tape location has been modified.

Customers having this concern should have their vehicle repaired using the following repair procedure.

REPAIR PROCEDURE

1. Verify the customer concern.
2. Repair the vehicle according to the following repair procedures.

For VIN range A (2024 CX-90 with VINS lower than JM3KK***133227 and produced before September 6, 2023)**

- a. Replace the driver's side outer mirror glass and the electric fold unit with modified ones according to the following procedures.

NOTE: If the vehicle has had the repair according to the previous version of this TSB, the driver's side outer mirror glass replacement is unnecessary.

- MGSS instructions (OUTER MIRROR GLASS REMOVAL/INSTALLATION)
- Out Mirror Glass Installation Note: #Outer Mirror Glass Installation Note
- Electric Fold Unit Replacement: #Electric Fold Unit Replacement

For VIN range B (For 2024 CX-90 VINS greater than JM3KK***133226 and all 2025 CX-90 and CX-70)**

Replace the driver's side electric fold unit assy. with modified one according to the following procedures.

- Electric Fold Unit Replacement: #Electric Fold Unit Replacement

CONSUMER NOTICE: The information and instructions in this bulletin are intended for use by skilled technicians. Mazda technicians utilize the proper tools/ equipment and take training to correctly and safely maintain Mazda vehicles. These instructions should not be performed by "do-it-yourselfers." Customers should not assume this bulletin applies to their vehicle or that their vehicle will develop the described concern. To determine if the information applies, customers should contact their nearest authorized Mazda dealership. Mazda North American Operations reserves the right to alter the specifications and contents of this bulletin without obligation or advance notice. All rights reserved. No part of this bulletin may be reproduced in any form or by any means, electronic or mechanical--including photocopying and recording and the use of any kind of information storage and retrieval system ---without permission in writing.

OUTER MIRROR GLASS INSTALLATION NOTE: Refer to the procedure below and perform the installation in the correct order when installing the outer mirror glass.

ATTENTION: DO NOT press the mirror glass too hard during installation to avoid damaging the auto-dimming liquid crystal inside the glass.

a. Install the new pivot plate (1) to the outer mirror base.

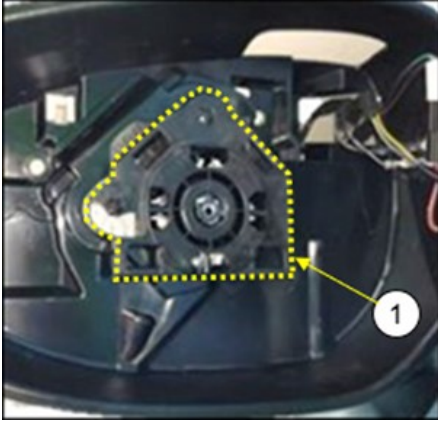

b. Peel off the release papers on the new mirror glass holder.

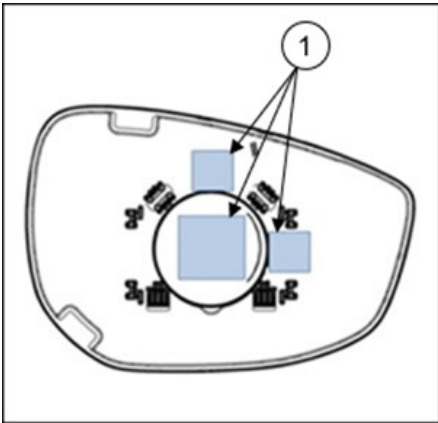

CONSUMER NOTICE: The information and instructions in this bulletin are intended for use by skilled technicians. Mazda technicians utilize the proper tools/ equipment and take training to correctly and safely maintain Mazda vehicles. These instructions should not be performed by "do-it-yourselfers." Customers should not assume this bulletin applies to their vehicle or that their vehicle will develop the described concern. To determine if the information applies, customers should contact their nearest authorized Mazda dealership. Mazda North American Operations reserves the right to alter the specifications and contents of this bulletin without obligation or advance notice. All rights reserved. No part of this bulletin may be reproduced in any form or by any means, electronic or mechanical---including photocopying and recording and the use of any kind of information storage and retrieval system ---without permission in writing.

c. Hook the tabs (1) of the outer mirror holder to the pivot plate (2) as shown in the image.

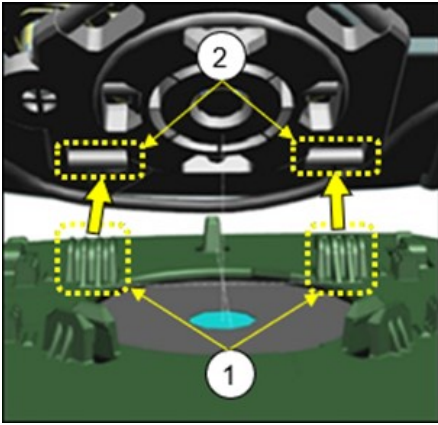

d. Hook the claws (1) of the outer mirror holder to the pivot plate (2) as shown in the image.

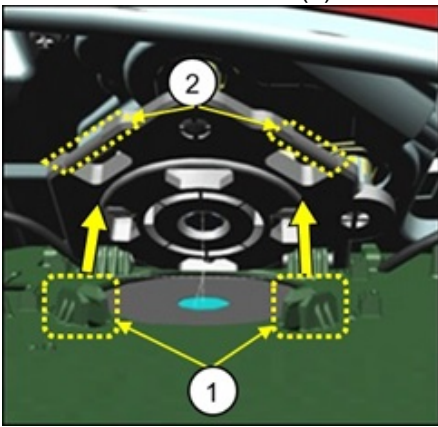

Electric Fold Unit Replacement (including Outer Mirror Disassembly/Reassembly)

a. Remove the driver's side outer mirror according to the instruction on MGSS (OUTER MIRROR GLASS REMOVAL/INSTALLATION).

b. Cut and remove the band clip (1) holding the wire harnesses.

NOTE: When installing, replace the band clip with the new one, which is included in the service parts kit.

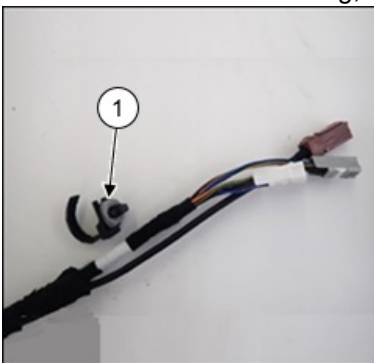

CONSUMER NOTICE: The information and instructions in this bulletin are intended for use by skilled technicians. Mazda technicians utilize the proper tools/ equipment and take training to correctly and safely maintain Mazda vehicles. These instructions should not be performed by "do-it-yourselfers." Customers should not assume this bulletin applies to their vehicle or that their vehicle will develop the described concern. To determine if the information applies, customers should contact their nearest authorized Mazda dealership. Mazda North American Operations reserves the right to alter the specifications and contents of this bulletin without obligation or advance notice. All rights reserved. No part of this bulletin may be reproduced in any form or by any means, electronic or mechanical---including photocopying and recording and the use of any kind of information storage and retrieval system ---without permission in writing.

INSTALLATION NOTE:

- 1) Remove the seal packing (1) on the wire harness, and then apply the new seal packing (1), which is included in the Electric Fold Unit Kit, as shown in the following image.
- 2) Install the new band clip (2), which is included in the Electric Fold Unit Kit, as shown in the following image.

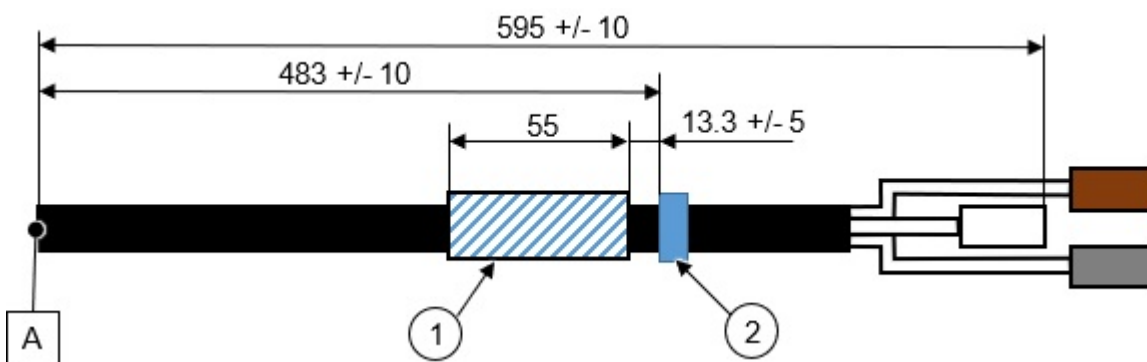
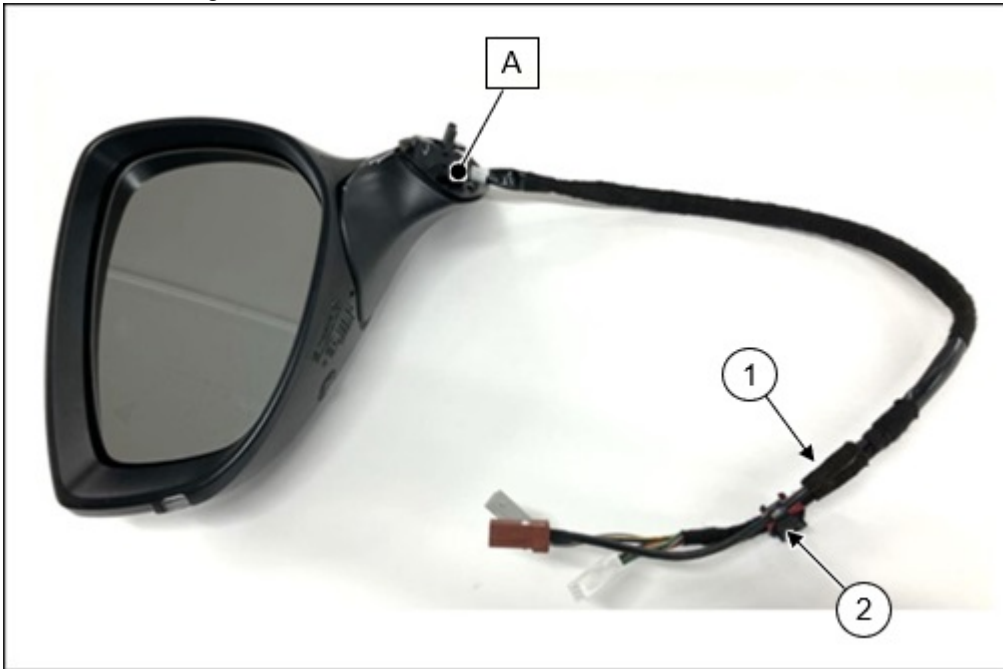

CONSUMER NOTICE: The information and instructions in this bulletin are intended for use by skilled technicians. Mazda technicians utilize the proper tools/ equipment and take training to correctly and safely maintain Mazda vehicles. These instructions should not be performed by "do-it-yourselfers." Customers should not assume this bulletin applies to their vehicle or that their vehicle will develop the described concern. To determine if the information applies, customers should contact their nearest authorized Mazda dealership. Mazda North American Operations reserves the right to alter the specifications and contents of this bulletin without obligation or advance notice. All rights reserved. No part of this bulletin may be reproduced in any form or by any means, electronic or mechanical---including photocopying and recording and the use of any kind of information storage and retrieval system ---without permission in writing.

c. Remove the seal rubber (1).

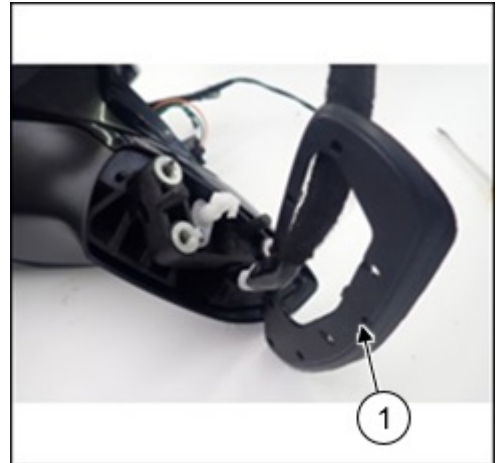

d. Unhook the three tabs (yellow arrows) and remove the base cover lower (1).

NOTE: When installing, replace the base cover lower with the new one, which is included in the service parts kit.

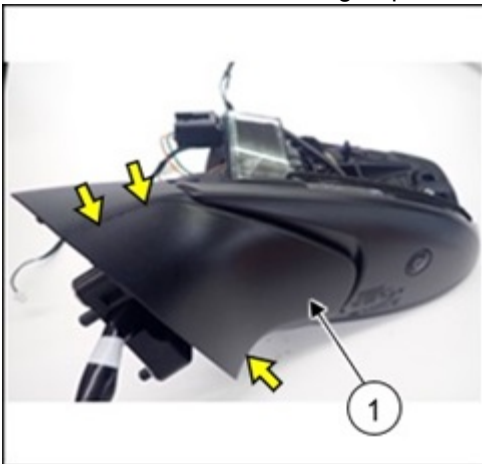

CONSUMER NOTICE: The information and instructions in this bulletin are intended for use by skilled technicians. Mazda technicians utilize the proper tools/ equipment and take training to correctly and safely maintain Mazda vehicles. These instructions should not be performed by "do-it-yourselfers." Customers should not assume this bulletin applies to their vehicle or that their vehicle will develop the described concern. To determine if the information applies, customers should contact their nearest authorized Mazda dealership. Mazda North American Operations reserves the right to alter the specifications and contents of this bulletin without obligation or advance notice. All rights reserved. No part of this bulletin may be reproduced in any form or by any means, electronic or mechanical---including photocopying and recording and the use of any kind of information storage and retrieval system ---without permission in writing.

e. Remove the bush-nut (2) and the three screws (3), and then remove the base cover upper (1).

NOTE:

- Use Tool: Torque wrench T25.
- When installing, replace the bush-nut and the base cover upper with the new ones, which is included in the service parts kit.

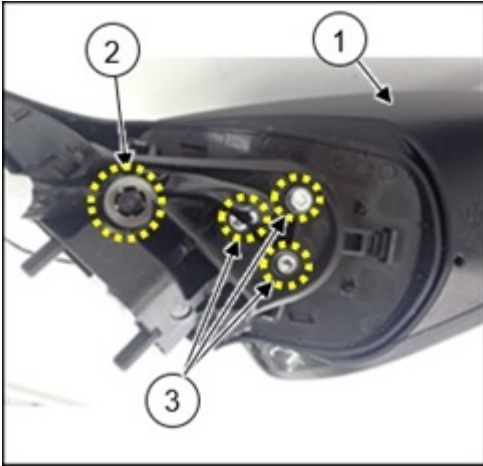

Tightening Torque: 51 +/- 8.8 in-lbf (6.0 +/- 1.0 N·m, 60 +/- 0.1 kgf·cm)

f. Remove the ACT harness (1) in the following order:

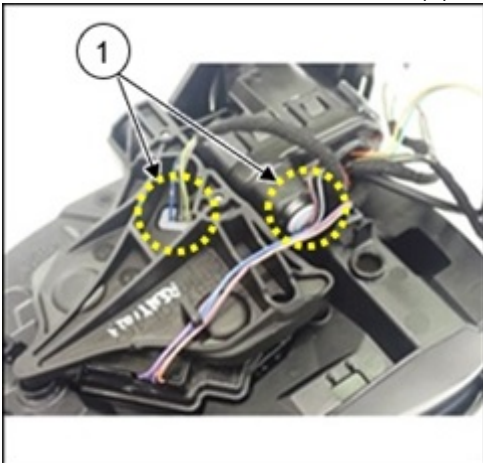

CONSUMER NOTICE: The information and instructions in this bulletin are intended for use by skilled technicians. Mazda technicians utilize the proper tools/ equipment and take training to correctly and safely maintain Mazda vehicles. These instructions should not be performed by "do-it-yourselfers." Customers should not assume this bulletin applies to their vehicle or that their vehicle will develop the described concern. To determine if the information applies, customers should contact their nearest authorized Mazda dealership. Mazda North American Operations reserves the right to alter the specifications and contents of this bulletin without obligation or advance notice. All rights reserved. No part of this bulletin may be reproduced in any form or by any means, electronic or mechanical---including photocopying and recording and the use of any kind of information storage and retrieval system ---without permission in writing.

- 1) Remove the grommets (2).
- 2) Remove the connectors (3).

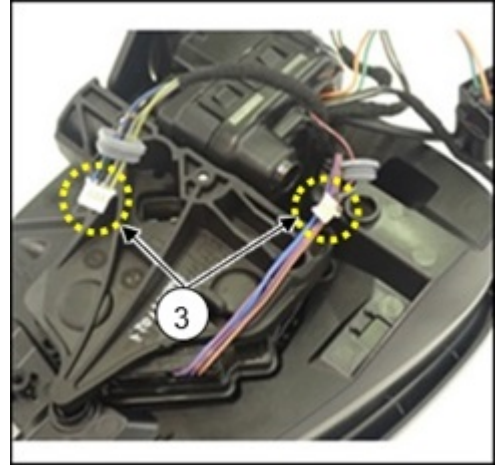
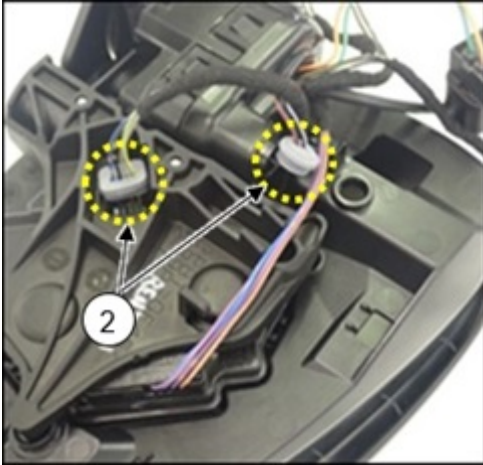

INSTALLATION NOTE: Hook (1) (2) the ACT wire harness and place it along the guide (3) when installing.

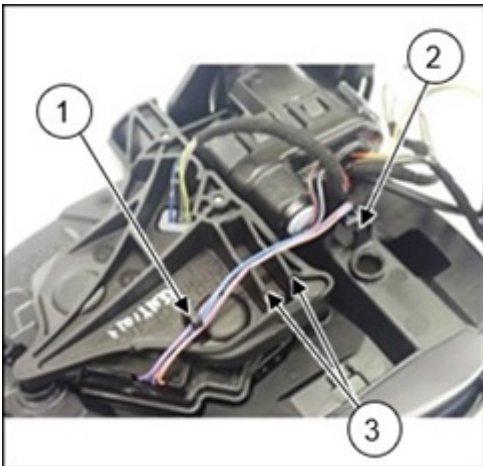

CONSUMER NOTICE: The information and instructions in this bulletin are intended for use by skilled technicians. Mazda technicians utilize the proper tools/ equipment and take training to correctly and safely maintain Mazda vehicles. These instructions should not be performed by "do-it-yourselfers." Customers should not assume this bulletin applies to their vehicle or that their vehicle will develop the described concern. To determine if the information applies, customers should contact their nearest authorized Mazda dealership. Mazda North American Operations reserves the right to alter the specifications and contents of this bulletin without obligation or advance notice. All rights reserved. No part of this bulletin may be reproduced in any form or by any means, electronic or mechanical---including photocopying and recording and the use of any kind of information storage and retrieval system ---without permission in writing.

g. Remove the four screws (1) (2), and then remove the mirror frame (3) and the electric fold unit (4).

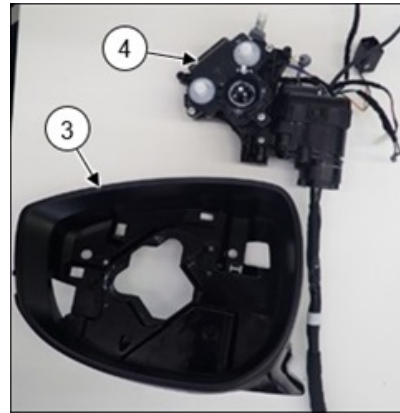

Tightening Torque:

(1) 10.62 in·lbf (1.2 N·m, 0.12 kgf·cm) - 23.9 in·lbf (2.7 N/m, 0.28kgf·cm)
 (2) 17 in·lbf (2.0 N·m, 20 kgf·cm) - 35 in·lbf (4.0 N/m, 40 kgf·cm, 35 in·lbf)

h. Remove the three screws (1), and then remove ATM (2) from the electric fold unit frame (3).

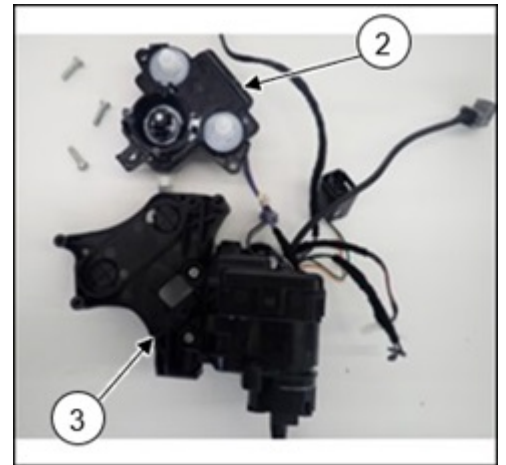
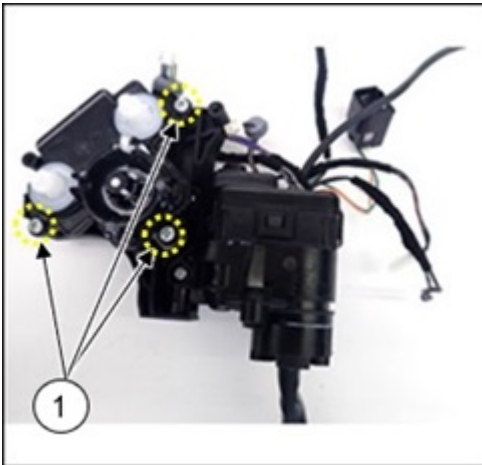

Tightening Torque: 10.6 in·lbf (1.2-2.7 N·m, 0.12 kgf·cm)

CONSUMER NOTICE: The information and instructions in this bulletin are intended for use by skilled technicians. Mazda technicians utilize the proper tools/ equipment and take training to correctly and safely maintain Mazda vehicles. These instructions should not be performed by "do-it-yourselfers." Customers should not assume this bulletin applies to their vehicle or that their vehicle will develop the described concern. To determine if the information applies, customers should contact their nearest authorized Mazda dealership. Mazda North American Operations reserves the right to alter the specifications and contents of this bulletin without obligation or advance notice. All rights reserved. No part of this bulletin may be reproduced in any form or by any means, electronic or mechanical---including photocopying and recording and the use of any kind of information storage and retrieval system ---without permission in writing.

i. Remove the wire harnesses from the electric fold unit frame in the following order.

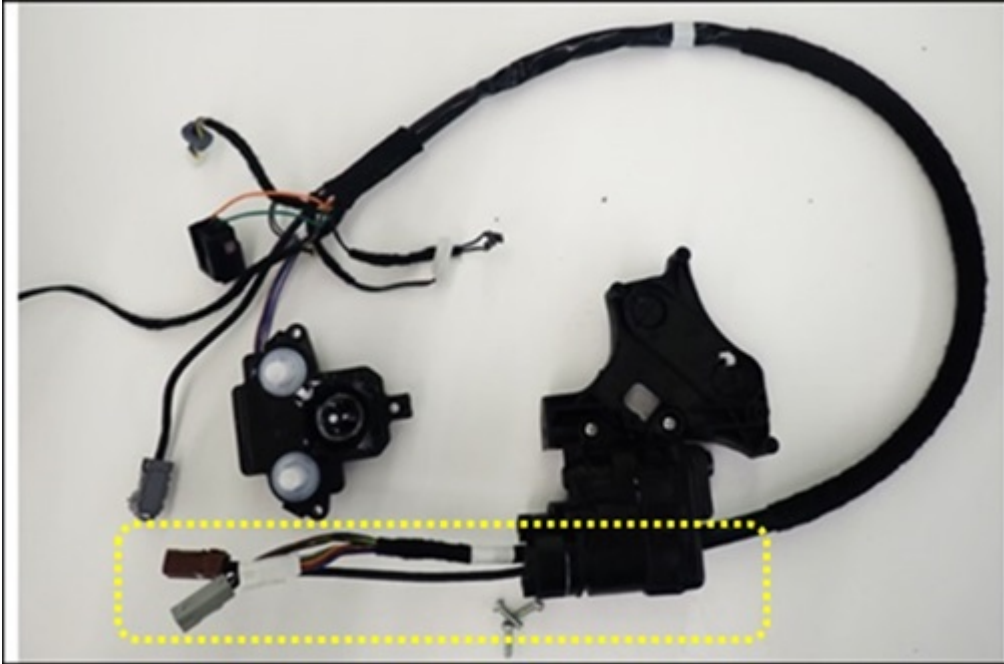

1) Remove the brown connector housing (1) from the camera connector terminal (2) according to "Connector Removal Note".

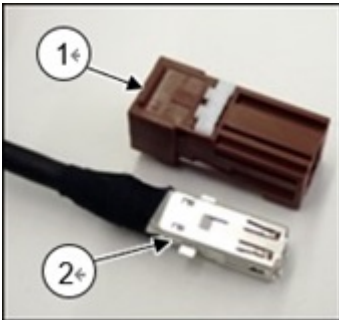

The connector housing removal has been completed.

CONSUMER NOTICE: The information and instructions in this bulletin are intended for use by skilled technicians. Mazda technicians utilize the proper tools/ equipment and take training to correctly and safely maintain Mazda vehicles. These instructions should not be performed by "do-it-yourselfers." Customers should not assume this bulletin applies to their vehicle or that their vehicle will develop the described concern. To determine if the information applies, customers should contact their nearest authorized Mazda dealership. Mazda North American Operations reserves the right to alter the specifications and contents of this bulletin without obligation or advance notice. All rights reserved. No part of this bulletin may be reproduced in any form or by any means, electronic or mechanical---including photocopying and recording and the use of any kind of information storage and retrieval system ---without permission in writing.

CONNECTOR REMOVAL NOTE:

a) Unlock the retainer (1) with a flat head screwdriver.

NOTE: Be careful when handling the side camera connector (2), as it is fragile.

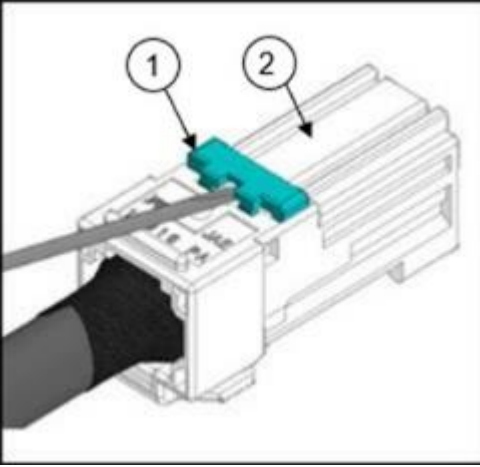

b) Insert a precision screwdriver or a needle (2) with a diameter of 1 mm or less into the hole (1) of the retainer (3) side.

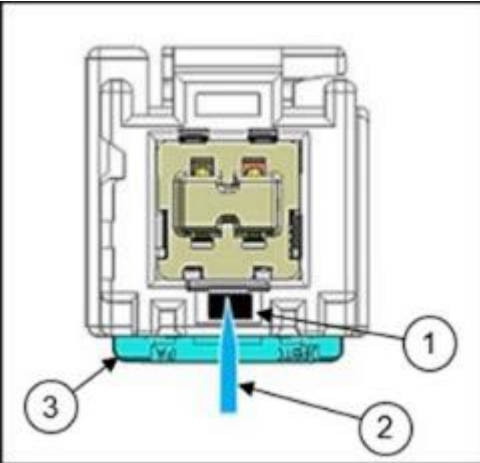

CONSUMER NOTICE: The information and instructions in this bulletin are intended for use by skilled technicians. Mazda technicians utilize the proper tools/ equipment and take training to correctly and safely maintain Mazda vehicles. These instructions should not be performed by "do-it-yourselfers." Customers should not assume this bulletin applies to their vehicle or that their vehicle will develop the described concern. To determine if the information applies, customers should contact their nearest authorized Mazda dealership. Mazda North American Operations reserves the right to alter the specifications and contents of this bulletin without obligation or advance notice. All rights reserved. No part of this bulletin may be reproduced in any form or by any means, electronic or mechanical---including photocopying and recording and the use of any kind of information storage and retrieval system ---without permission in writing.

c) Press down the screwdriver or the needle (1) to push the latch (2) down.

NOTE: Insert the tip (4) of the screwdriver or the needle along the metal part (5) of the terminal.

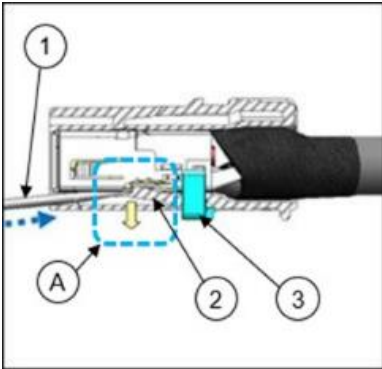

(3): Retainer

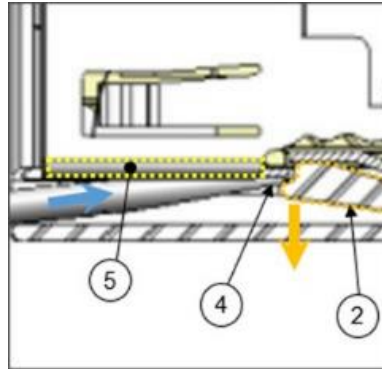

Detail of A

d) Pull out the connector housing (1) while pushing down the latch (2).

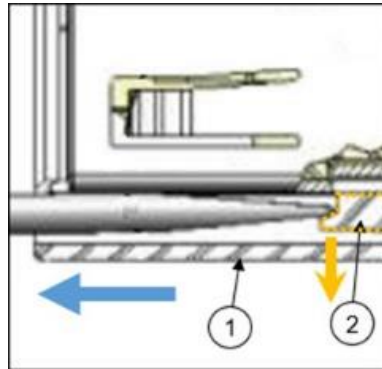
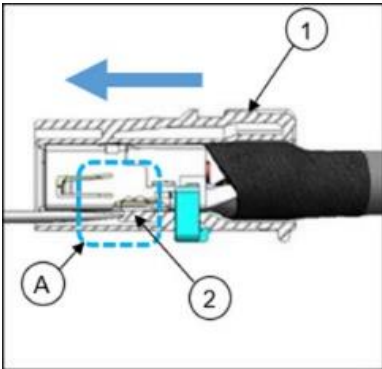

DETAIL OF A

2) Remove the camera harness (1) from the electric fold unit (2) first.

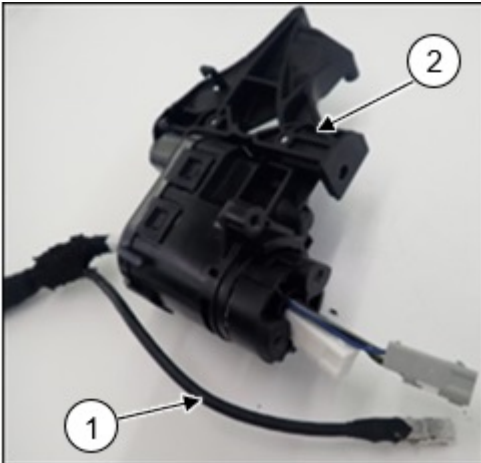

CONSUMER NOTICE: The information and instructions in this bulletin are intended for use by skilled technicians. Mazda technicians utilize the proper tools/ equipment and take training to correctly and safely maintain Mazda vehicles. These instructions should not be performed by "do-it-yourselfers." Customers should not assume this bulletin applies to their vehicle or that their vehicle will develop the described concern. To determine if the information applies, customers should contact their nearest authorized Mazda dealership. Mazda North American Operations reserves the right to alter the specifications and contents of this bulletin without obligation or advance notice. All rights reserved. No part of this bulletin may be reproduced in any form or by any means, electronic or mechanical---including photocopying and recording and the use of any kind of information storage and retrieval system ---without permission in writing.

3) Remove other two wire harnesses (1).

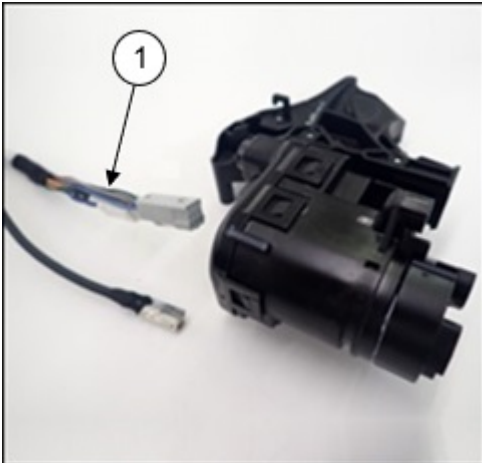

j. Replace removed parts with those in the Electric Fold Unit Kit.

k. Reassemble and install the outer mirror in reverse order of the removal.

NOTE: Refer to the "Installation Notes" in the removal procedure for Electric Fold Unit Replacement.

3. Verify the repair

PARTS INFORMATION

| Parts Number | Description | Quantity | Notes |
|--------------|------------------------------|----------|--|
| KMY0-69-16Z | Actuator (L) | 1 | Electric Fold Unit Kit; Left |
| KEY0-69-1GY | Glass and Holder (L), Mirror | 1 | Only for the repair of VIN range A models (refer to VIN range table) |
| KR9P-69-115 | Cover, Hole | 1 | [R] |

NOTE: Use VIN to check the old part number in EPC.

CONSUMER NOTICE: The information and instructions in this bulletin are intended for use by skilled technicians. Mazda technicians utilize the proper tools/ equipment and take training to correctly and safely maintain Mazda vehicles. These instructions should not be performed by "do-it-yourselfers." Customers should not assume this bulletin applies to their vehicle or that their vehicle will develop the described concern. To determine if the information applies, customers should contact their nearest authorized Mazda dealership. Mazda North American Operations reserves the right to alter the specifications and contents of this bulletin without obligation or advance notice. All rights reserved. No part of this bulletin may be reproduced in any form or by any means, electronic or mechanical--including photocopying and recording and the use of any kind of information storage and retrieval system ---without permission in writing.

ACTUATOR (L) (Electric Fold Unit Kit; Left)

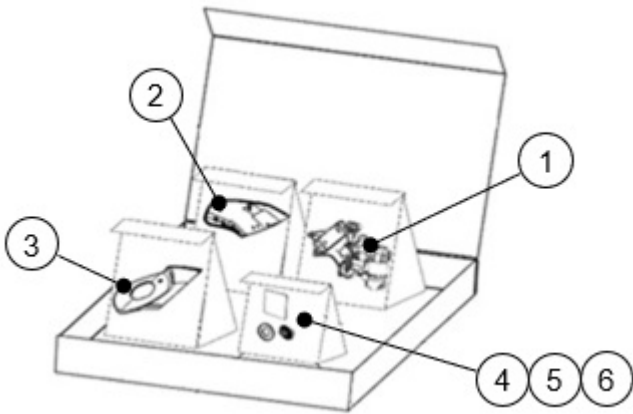

| | |
|---|---------------------------------|
| 1 | Electric Folding Unit and Frame |
| 2 | Cover Base Lower |
| 3 | Cover Base Upper |
| 4 | Seal Packing |
| 5 | Band Clip |
| 6 | Push Nut |

Modified Electric Folding Unit and Frame

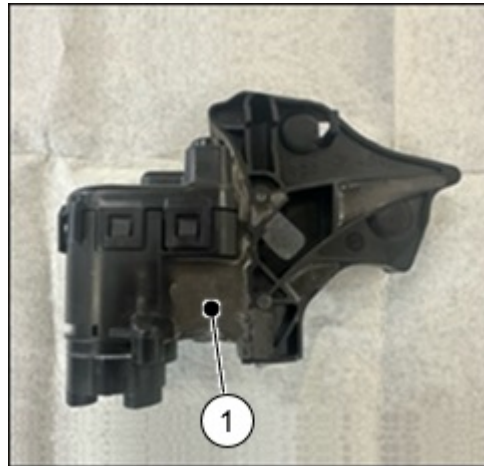

(1) Devcon®

CONSUMER NOTICE: The information and instructions in this bulletin are intended for use by skilled technicians. Mazda technicians utilize the proper tools/ equipment and take training to correctly and safely maintain Mazda vehicles. These instructions should not be performed by "do-it-yourselfers." Customers should not assume this bulletin applies to their vehicle or that their vehicle will develop the described concern. To determine if the information applies, customers should contact their nearest authorized Mazda dealership. Mazda North American Operations reserves the right to alter the specifications and contents of this bulletin without obligation or advance notice. All rights reserved. No part of this bulletin may be reproduced in any form or by any means, electronic or mechanical---including photocopying and recording and the use of any kind of information storage and retrieval system ---without permission in writing.

Replacement part location

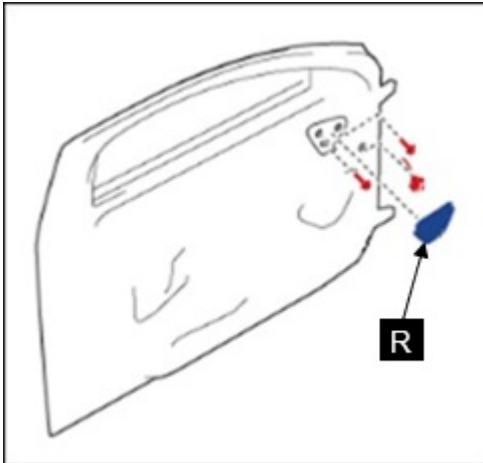

WARRANTY INFORMATION

NOTE:

- This warranty information applies only to verified customer complaints on vehicles eligible for warranty repair.
- This repair will be covered under Mazda’s New Vehicle Limited Warranty term.
- Additional diagnostic time cannot be claimed for this repair.

| | |
|---------------------------------|---|
| Warranty Type | A |
| Symptom Code | 83 |
| Damage Code | 97 |
| Part Number Main Cause | KMY0-69-16Z |
| Quantity | 1 |
| Operation Number / Labor Hours: | XXWJ6PRX / 0.8 Hrs. (without 360°view monitor system) XXWJ6RRX / 0.9 Hrs. (with 360°view monitor system) XXWJ6SRX / 1.1 Hrs (with 360°view monitor system and aiming) |

NOTE: Claim Hole Cover and/or Outer Mirror Glass as related parts.

CONSUMER NOTICE: The information and instructions in this bulletin are intended for use by skilled technicians. Mazda technicians utilize the proper tools/ equipment and take training to correctly and safely maintain Mazda vehicles. These instructions should not be performed by "do-it-yourselfers." Customers should not assume this bulletin applies to their vehicle or that their vehicle will develop the described concern. To determine if the information applies, customers should contact their nearest authorized Mazda dealership. Mazda North American Operations reserves the right to alter the specifications and contents of this bulletin without obligation or advance notice. All rights reserved. No part of this bulletin may be reproduced in any form or by any means, electronic or mechanical--including photocopying and recording and the use of any kind of information storage and retrieval system ---without permission in writing.