



SERVICE BULLETIN

— Confidential and Proprietary —

Release Date: February 16, 2024

SLI

Communication #: T-24-02

Expiration Date: February 16, 2026

Model Year(s): 2023-2024

VERSION: R01 (February 16, 2024)

Revision	Release Date	Update
R01	2/16/2024	Initial Service Bulletin Release
R02	2/27/2025	Extended expiration date to 2/16/2026

If you are working with a printed copy, please verify you have the most current version of this document.

SUBJECT: TIMING CHAIN OIL JET

PURPOSE

Polaris has determined that some 2023 and 2024 Slingshot models may have a plugged timing chain oil jet which could result in a lack of oil to the timing chain guides and risk causing severe engine damage.

To address this concern, Polaris has released this Service Bulletin with instructions to inspect the oil jet, and replace if needed. The affected population is less than 40 VINs.

AFFECTED MODELS

MODEL YEAR	MODELS	AFFECTED RANGE
2023	All Slingshot Models (Limited Quantities)	Reference Unit Inquiry on the dealer website or the Service Communications list on the STOP site to look up affected units.
2024		

CUSTOMER NOTIFICATION

Dealers are required to review their sales records and make arrangements with customers for Bulletin completion. In addition to consumer units, dealers are required to correct any affected units in their inventory. Polaris will be making phone calls to the consumers affected by this Bulletin. Polaris will also send an email to owners for whom Polaris has a valid email address.

CONTACT POLARIS

If you have questions that are not addressed in this document, contact Polaris Service through Ask Polaris or by phone at 800-330-9407 (US/Canada Dealers Only).

DEALER - WHAT TO DO?

As of February 16, 2024, **YOU MUST NOT SELL OR DELIVER** any **NEW OR USED Model Year 2023-2024 Slingshot** vehicles affected by this **Service Bulletin** until it is repaired.

WARRANTY CLAIM INFORMATION

TIMING CHAIN OIL JET INSPECTION	
Bulletin #	T-24-02-AA
Claim Type	SB (Service Bulletin)
Labor Allowance	0.7 hours (42 minutes)
Part Number / Description	5814467 (QTY 1) Gasket, Valve Cover 7081496 (QTY 2) Clip, Fir Tree
Parts Availability	Available to order
University of Polaris Video Training Required	NO

TIMING CHAIN OIL JET REPLACEMENT	
Bulletin #	T-24-02-AB
Claim Type	SB (Service Bulletin)
Labor Allowance	5.3 hours (318 minutes)
Part Number / Description	<ul style="list-style-type: none"> • 2521817 (QTY 1) Jet, Oil • 7081496 (QTY 2) Clip, Fir Tree • 5814467 (QTY 1) Gasket, Valve Cover • 3023187 (QTY 1) Guide, Chain Tension • 3023186 (QTY 1) Guide, Chain Fixed • 3023188 (QTY 1) Guide, Chain Upper • 5418710 (QTY 1) Belt, Stretch • 2884537 (QTY 1) Engine Oil, 5W-50 (Gallon) • 2884536 (QTY 2) Engine Oil, 5W-50 (Quart) • 2521728 (QTY 1) Filter, Oil • 2871557 (QTY 1) Crankcase Sealant, Three Bond 1215 (5 oz.)
Parts Availability	Available to order
University of Polaris Video Training Required	NO

Claim Submission:

- Submit photos of the oil jet to an ASK Polaris>Diagnostics case, add T-24-02 to the case description, and wait for further instructions from Polaris Technical Service.

COVERAGE PERIOD

Coverage will begin on February 16, 2024. Coverage will expire on February 16, 2026.

FEEDBACK FORM

A feedback form has been created for the technician to provide Polaris with an overall satisfaction rating for the instructions, provide comments on your experience or upload pictures/video. The form is viewable on mobile devices by scanning the QR code or on a PC by clicking [HERE](#).



INSPECTION PROCEDURE

T-24-02-AA - TOOLS REQUIRED

- Pliers, Side Cutting
- Socket Set, Metric
 - Socket Size: 8, 10 mm
- Socket Set, Torx® Bit
 - Socket Size: T40
- Torque Wrench
- **Special Service Tool:**
 - 90° / Dual Lens Borescope
- Air Compressor, Long Nosed Air Gun

T-24-02-AA - OIL JET INSPECTION

VEHICLE PREPARATION

1. Park vehicle on a flat surface.
2. Shift vehicle to NEUTRAL
3. Apply parking brake.
4. Press START/STOP button to turn vehicle OFF.
5. Remove key fob from proximity of vehicle.

VALVE COVER REMOVAL

⚠ WARNING

A hot engine can cause serious burns. Allow engine to cool or wear protective gloves when removing the spark plugs.

1. Disconnect the breather hose by removing clip ① from the valve cover fitting.

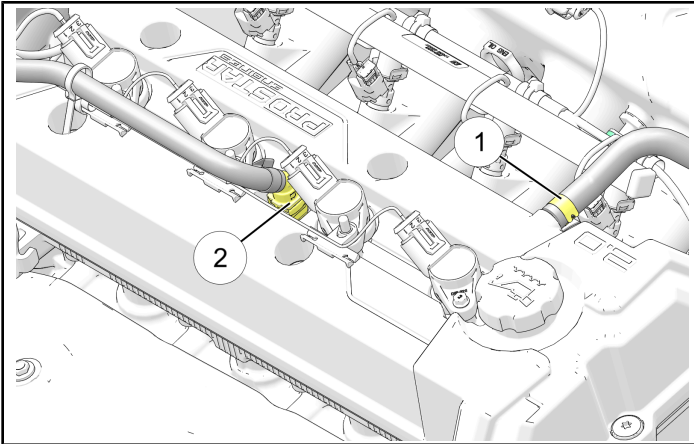

- a. Insert a #1 flat blade screw driver into the pry slot on the top of the retaining clip ②.

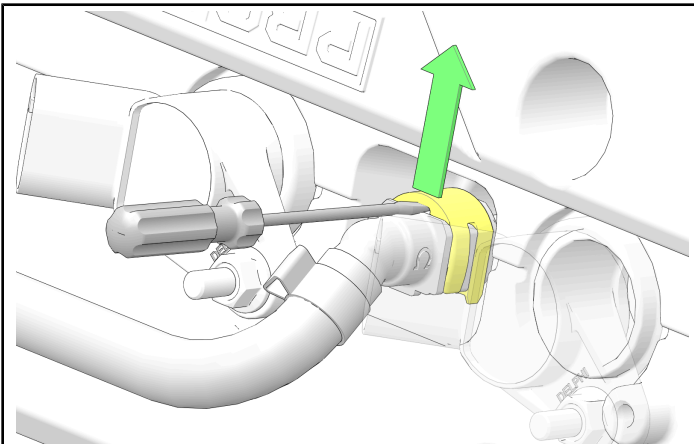

IMPORTANT

To prevent damage to the retaining clip, be sure to use a flat blade screwdriver that fits into the pry slot.

- b. Gently pry the retaining clip upwards into the open position.

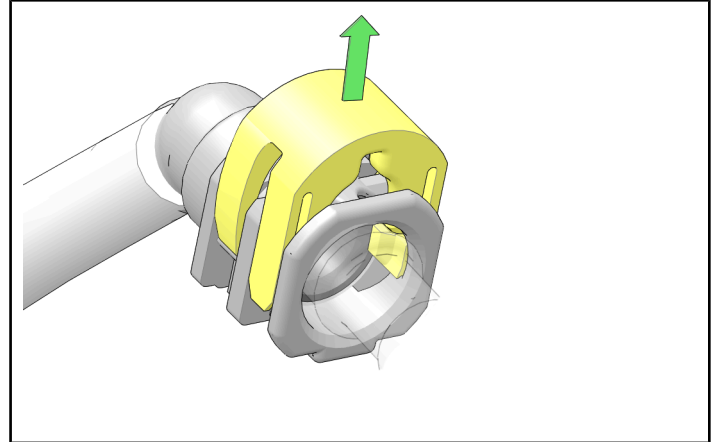

- c. Remove quick connect from the cylinder head air vent fitting.

IMPORTANT

Place a shop rag over the end of the coolant line to catch any fluid that may be in the line.

NOTICE

It is not necessary to remove the coolant vent line fitting from the cylinder head, the valve cover will come off over it. The vent line can be removed with the coil harness to avoid cutting the double zip tie.

2. Unplug the spark plug wire connectors ③ from the ignition coils.

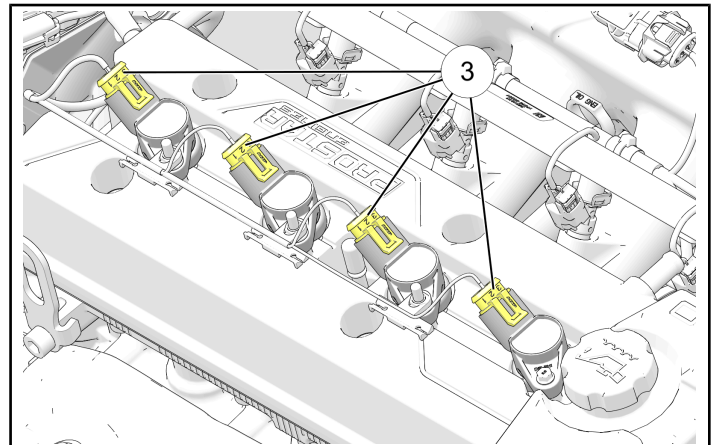

3. Using 8mm & 10mm sockets, remove the ignition coil fasteners ④.

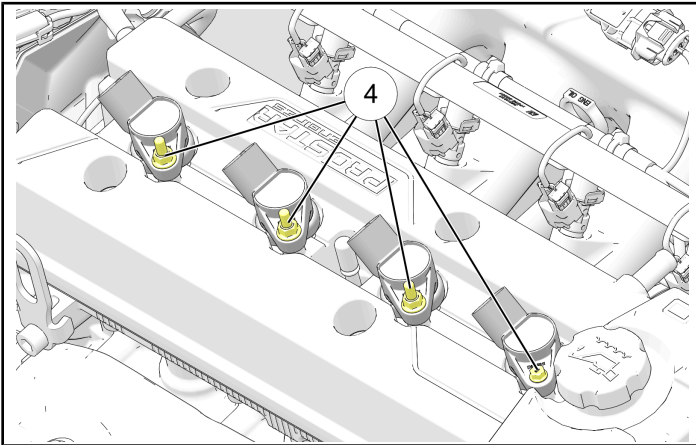

IMPORTANT

Before removing the ignition coils, clean out plug wells with compressed air to remove any loose dirt or debris.

4. Remove ignition coils ⑤.

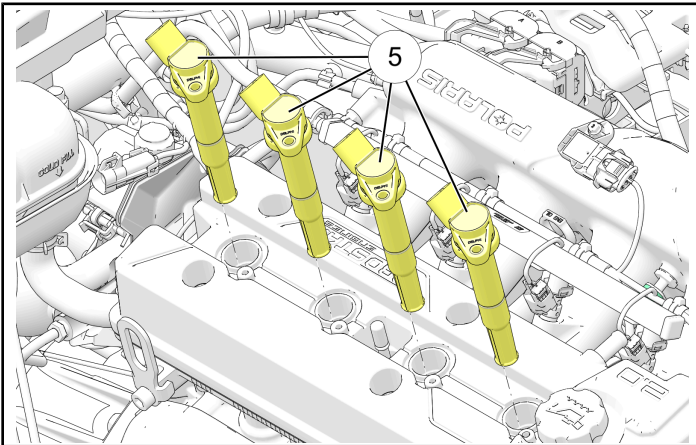

5. Snip the electrical tie downs ⑥ and leave the fir trees in the valve cover.

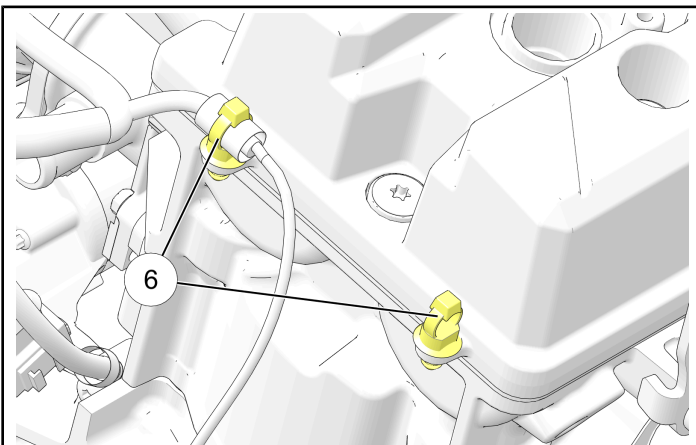

6. Using compressed air, blow out the vent fitting cavity to remove any dust or debris prior to removing the valve cover.
7. Using a T40 socket, remove valve cover fasteners ⑦. Remove valve cover and gasket. DISCARD gasket ⑧.

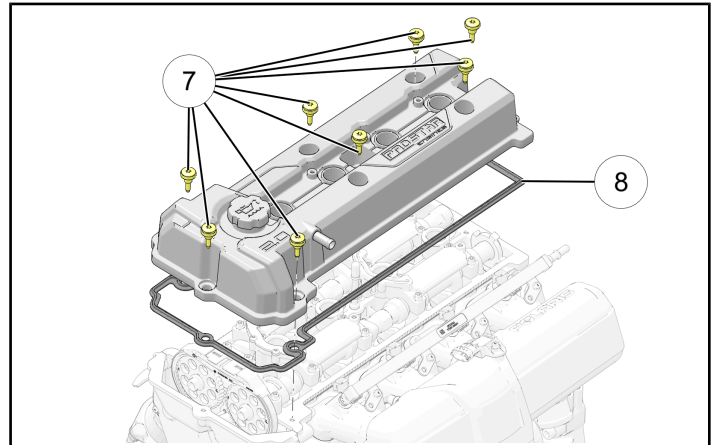

8. Connect the coolant line quick connect to the coolant vent line fitting to avoid loss of coolant during inspection.

OIL JET INSPECTION

NOTICE

Due to the tight proximity to the front cover, a 90 degree borescope will be needed to get a clear image of the jet for inspection. If you do not have access to a 90 degree borescope, and are not willing to purchase one, the front timing cover will need to be removed for jet inspection.

1. Locate the oil jet located behind the front cover as shown.

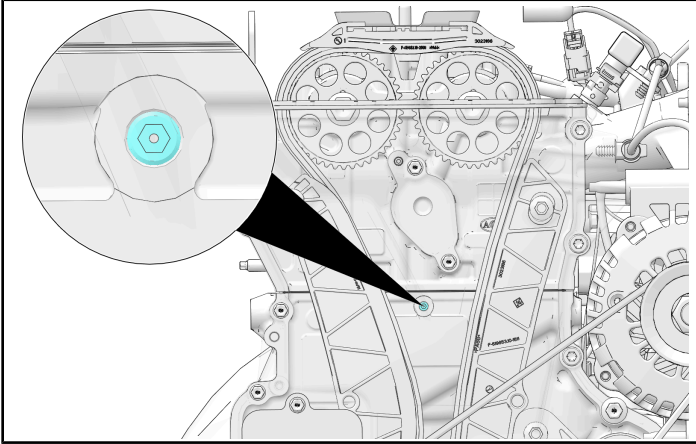

3. Insert a borescope into the gap between the front cover and cam chain.

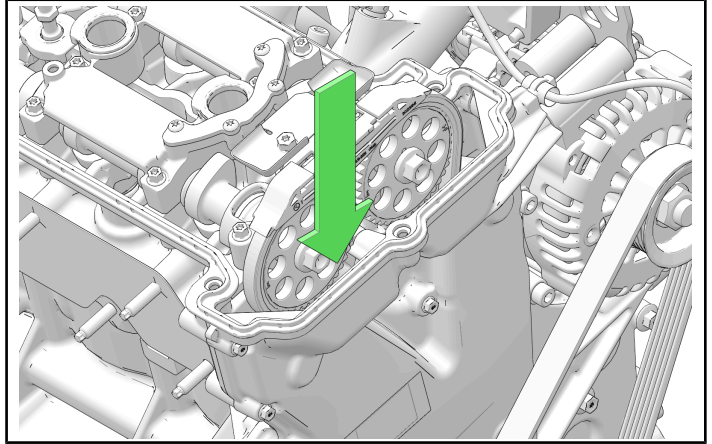

2. Use a long nose air gun to clear any oil from the oil jet.

OIL JET IS NOT PLUGGED

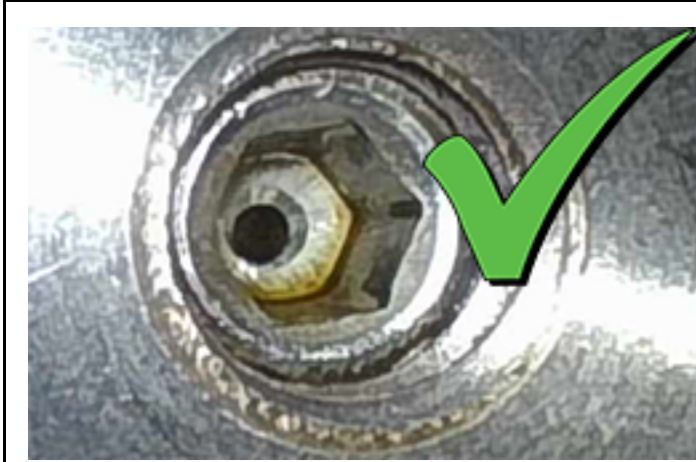

OIL JET IS PLUGGED

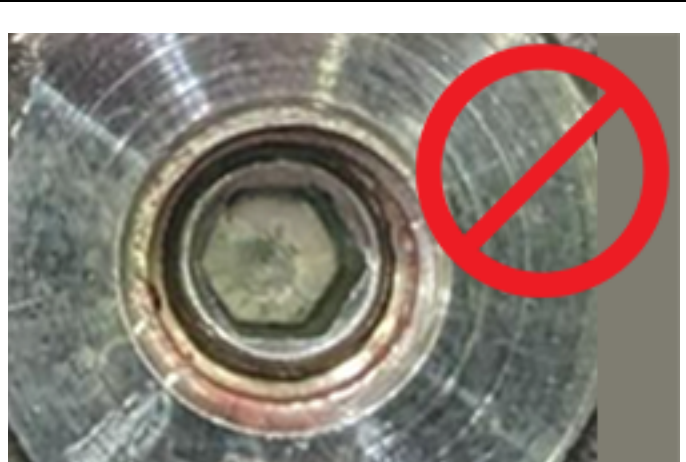

NOTICE

Make sure to blow air to remove oil from jet to clear any oil from the oil jet.

STOP!

- If the oil jet **IS** plugged, take pictures of the plugged jet and start an ASK Polaris Case. Submit an Ask Polaris Service & Warranty Question> All Vehicle Diagnostic case. Add "T-24-02-AB inspection FAIL" in the concern statement.
- If the oil jet **NOT** plugged, take pictures of the jet and start an ASK Polaris Case.
- Submit an Ask Polaris Service & Warranty Question> All Vehicle Diagnostic case. Add "T-24-02-AA inspection PASS" in the concern statement.

The information contained within this document is confidential and protected by U.S. and international copyright laws, and is the property of Polaris Inc. This document is provided for the sole use of authorized Polaris dealers and distributors. This document is not to be distributed, duplicated, or copied, digitally or otherwise, without the written consent of Polaris Inc.

VALVE COVER INSTALLATION

1. Assemble the valve cover and a NEW gasket ⑧ (5814467). Make sure that the gasket is located in the retaining groove in the valve cover.

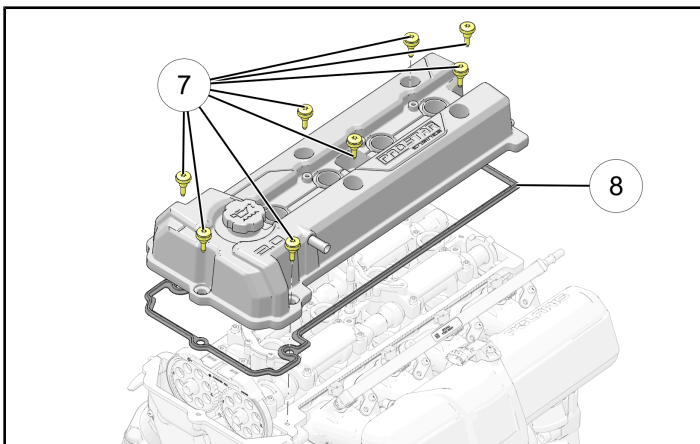

IMPORTANT

Apply liquid engine sealant at the T-Joint

2. Install the cover on the cylinder head and hand start the fasteners ⑦. Using sequence shown, torque fasteners to specification.

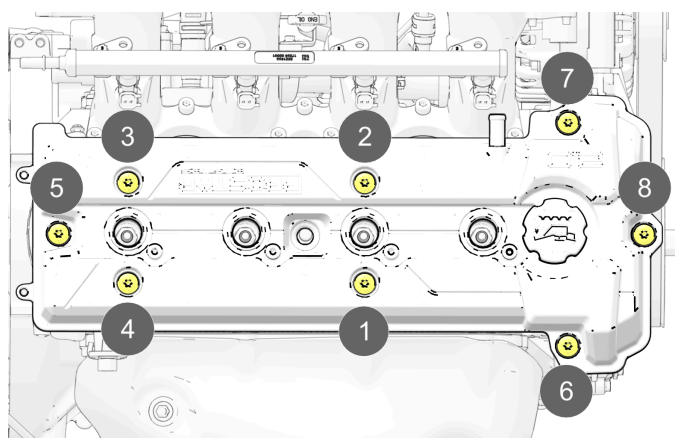

TORQUE

Valve Cover Fasteners:
89 in-lbs (10 N·m)

3. Install new cable ties ⑥ to the valve cover.

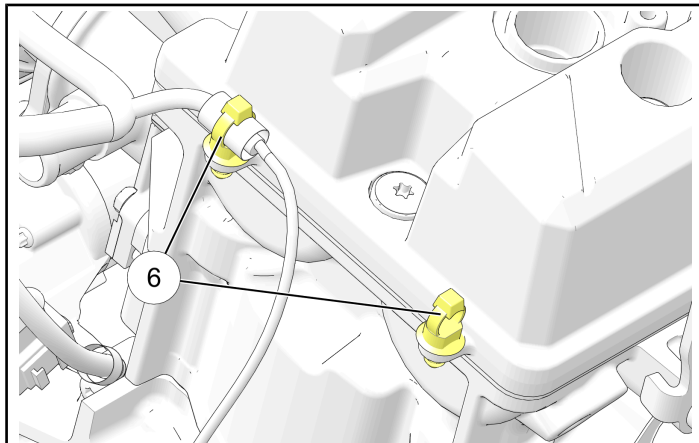

4. Install the ignition coils ⑤.

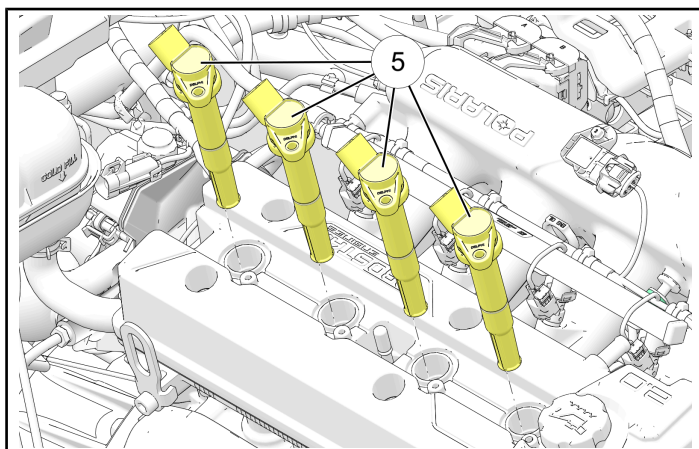

5. Install the ignition coil fasteners ④. Torque to specification

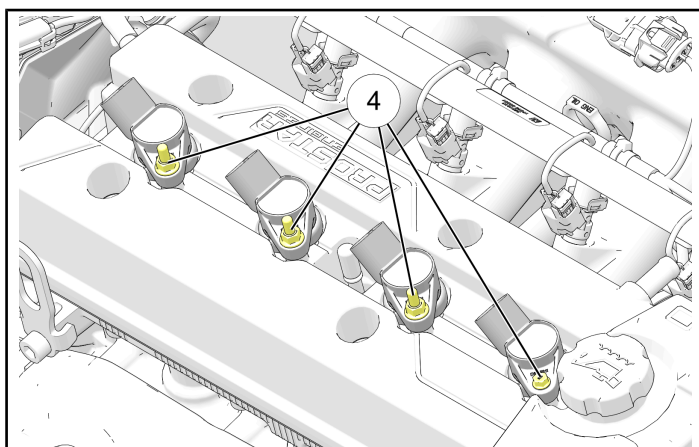

TORQUE

Ignition Coil Retaining Fasteners:
80 in-lbs (9 N·m)

6. Connect the spark plug wire connectors ③ to the ignition coils.

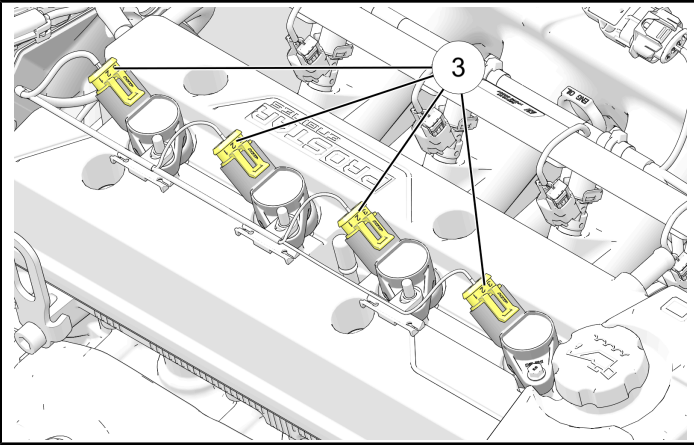

7. Connect the breather hose by securing clip ① to the valve cover fitting. Connect the coolant vent line fitting ②.

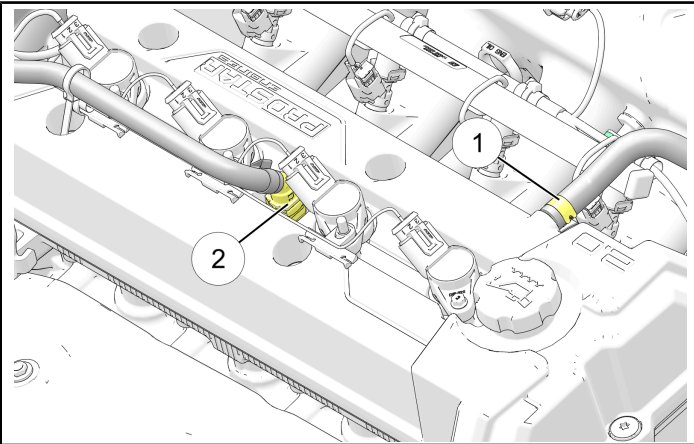

NOTICE

Listen for an audible click when connecting the coolant line fitting and gently pull on the connector to make sure the line is fully connected.

REPAIR PROCEDURE

T-24-02-AB - TOOLS REQUIRED

- Pliers, Side Cutting
- Socket Set, Metric
 - Socket Size: 8, 10 mm
- Socket Set, Torx® Bit
 - Socket Size: T40
- Wrench Set, Metric
 - Wrench Size: 8, 10 mm
- Torque Wrench
- **Special Service Tool:**
 - Belt Stretch Tool - **OTC 7425 or equivalent**
 - Oil Filter Socket - **PU-52890**
- Scraper

T-24-02-AB - OIL JET REPLACEMENT

ALTERNATOR REMOVAL

1. Remove the two fasteners securing the battery cover to the battery bracket.

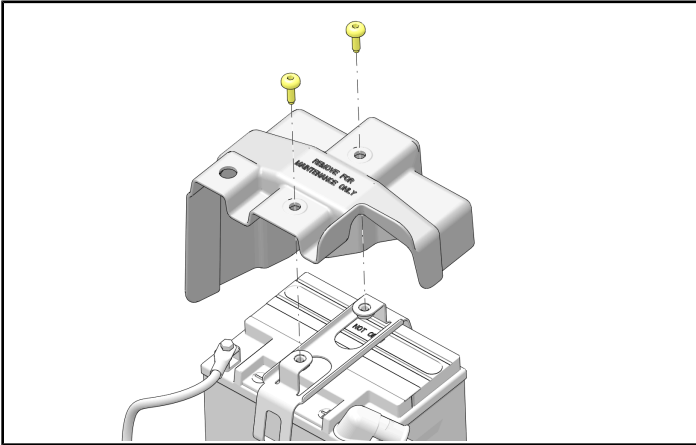

2. Loosen negative (-) battery terminal bolt and disconnect.

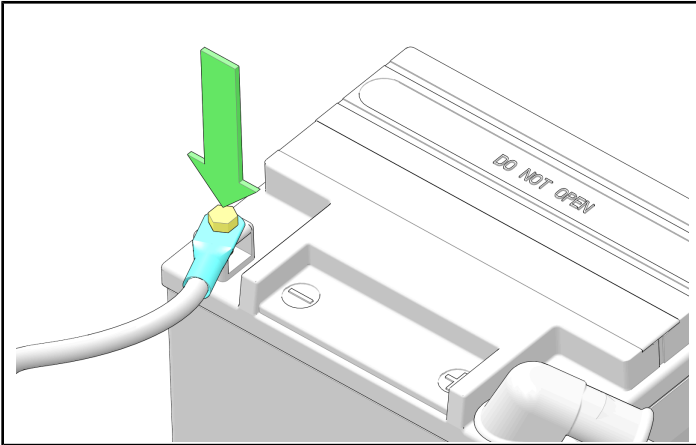

3. Disconnect the breather tube ① from the valve cover. Loosen two worm clamps ② and remove the intake air boot and breather hose.

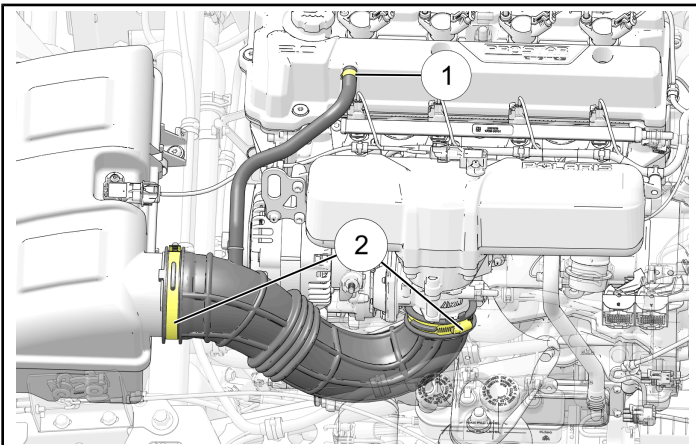

4. Remove positive terminal nut ③ and disconnect the main charging lead from the alternator.

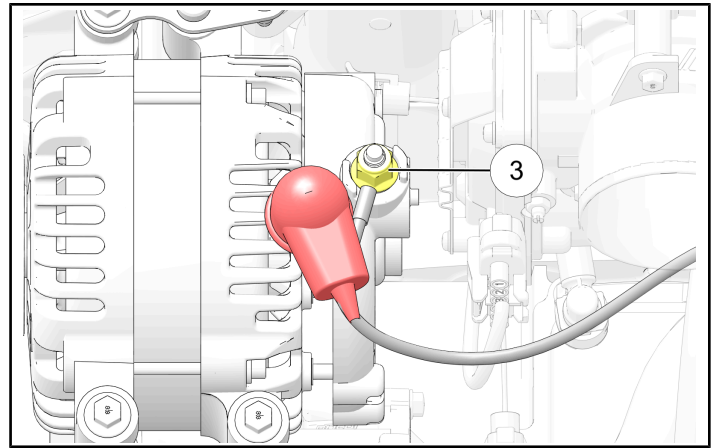

5. Disconnect the alternator electrical connector.

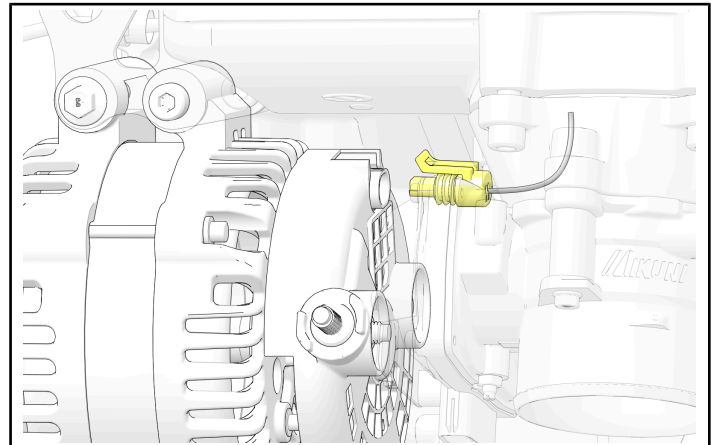

6. Cut the stretch belt and remove.

7. Remove three bolts ④ securing the alternator to the engine block and three bolts ⑤ securing the alternator to the intake manifold. Remove the alternator.

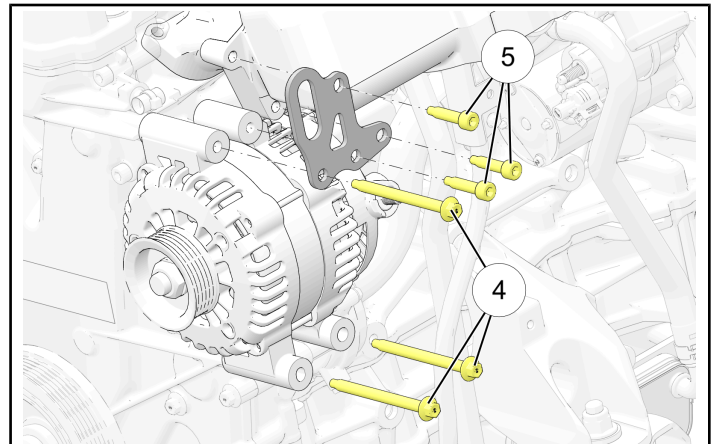

HARMONIC DAMPER REMOVAL

1. Remove three fasteners ① and coolant bracket ② to gain additional access.

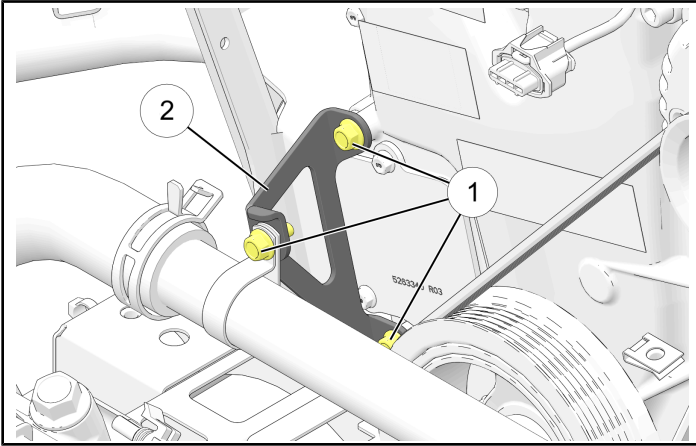

NOTICE

The radiator hoses do not need to be disconnected.

2. Cut the stretch belt and remove.
3. Disconnect the cooling fan electrical connectors ③ and remove retaining clips from the shroud.

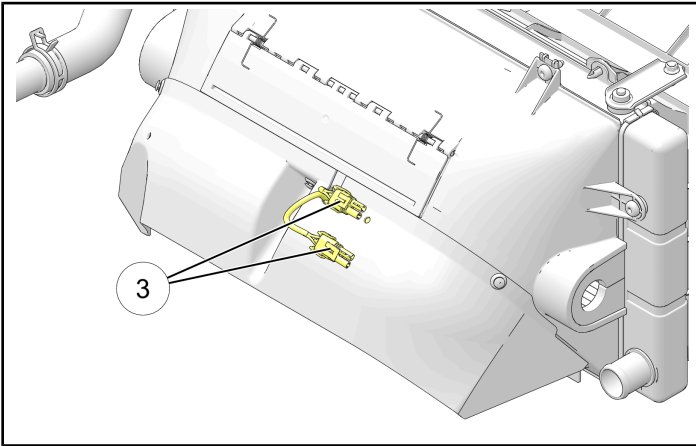

4. Remove push-rivets and pull lower shroud upward out of the clip on the fan shroud.

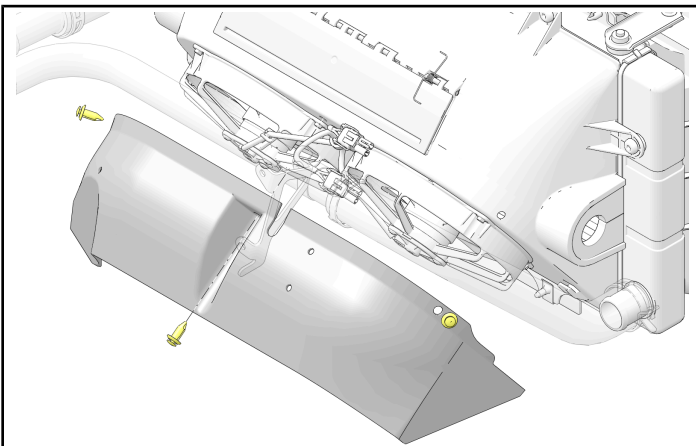

5. Remove the fasteners ④ holding the rear radiator shroud to the radiator assembly and remove the shroud..

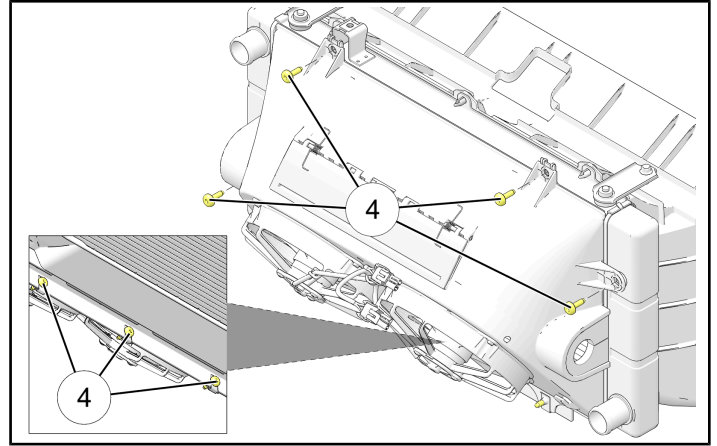

6. Rotate the engine to top dead center aligning the Intake and Exhaust camshaft sprockets to the cylinder head with the index marks.
7. Using special tool PU-52810 to hold the harmonic damper, remove the harmonic damper fastener ⑤ and washer.

8. Using the recommended 3-jaw puller, remove the harmonic damper ⑥.

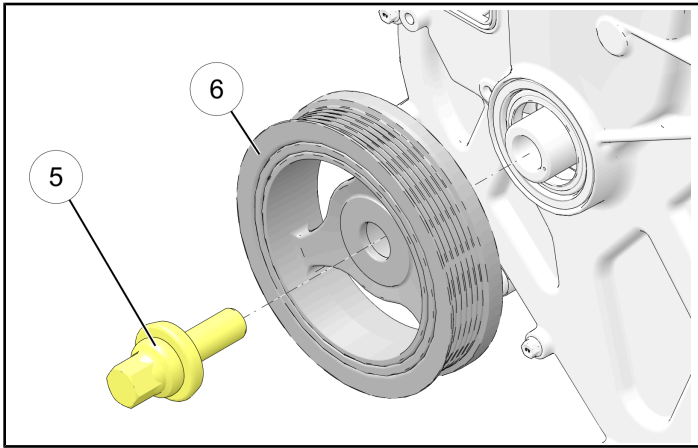

NOTICE

Recommended 3-Jaw puller:
OTC 6667

IMPORTANT

Place the 3-jaw puller on the inside arms of the damper during removal as shown. NEVER place force on the outside of the harmonic damper as damage will occur.

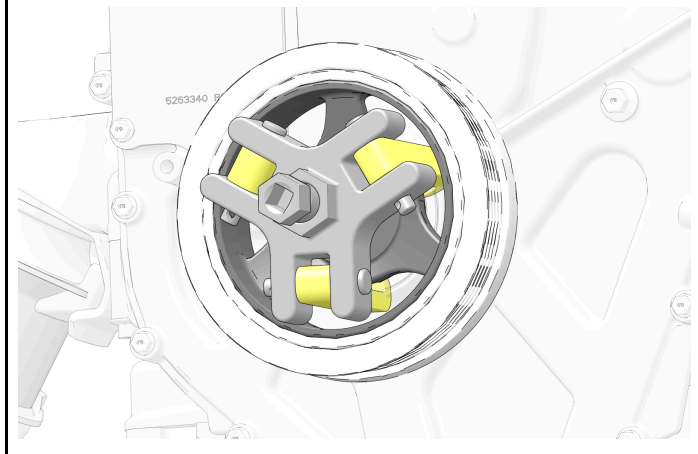

FRONT COVER REMOVAL

1. Remove fasteners ⑦, ⑧ and ⑨ and remove the front cover.

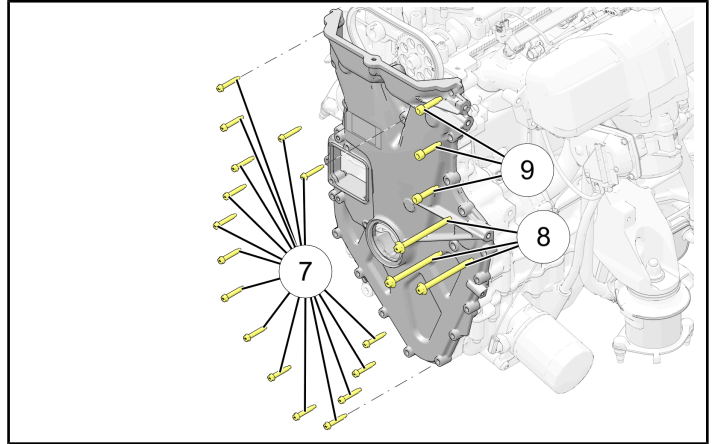

OIL JET REPLACEMENT

1. Locate and remove the oil jet.

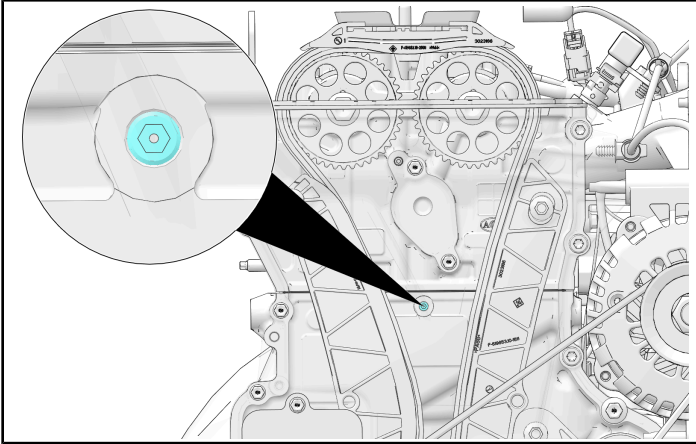

2. Install NEW oil jet and torque to specification.

TORQUE

Oil Jet:
35 in-lbs (4 N·m)

3. Verify that the NEW jet is installed and that it is not plugged.

TIMING CHAIN GUIDE REMOVAL

1. Remove the top chain guide fasteners and guide. Discard the top chain guide.

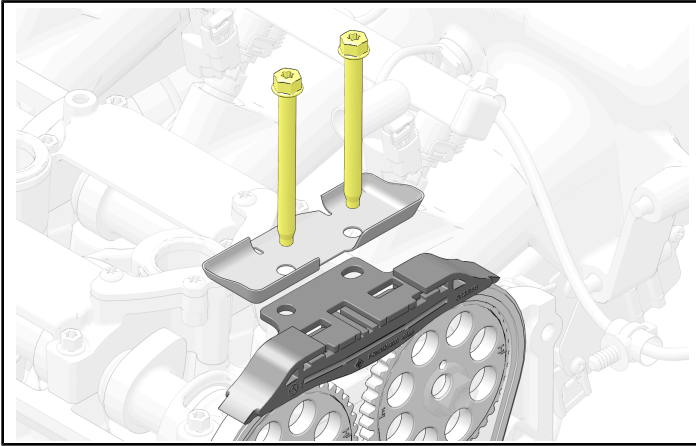

2. Instal NEW top chain guide and fasteners. Torque fasteners to specification

TORQUE

Camshaft Carrier Fasteners:
13 ft-lbs (17 N·m)

3. Remove chain tensioner fastener ③ and chain tensioner.

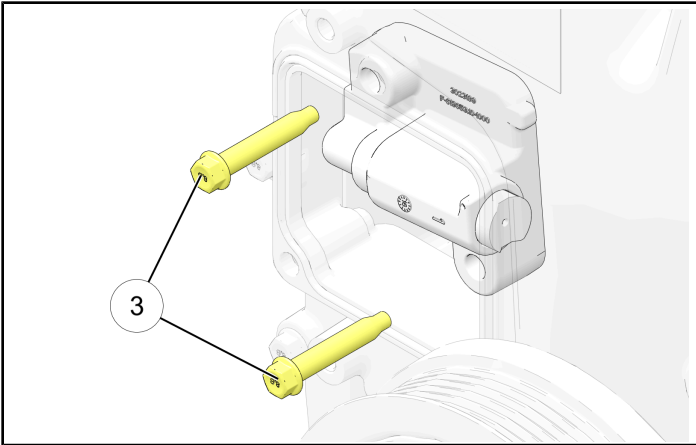

4. Remove both fixed guide ⑤ and adjustable guide ① by removing the fasteners ② and ④. Discard the fixed and adjustable guides.

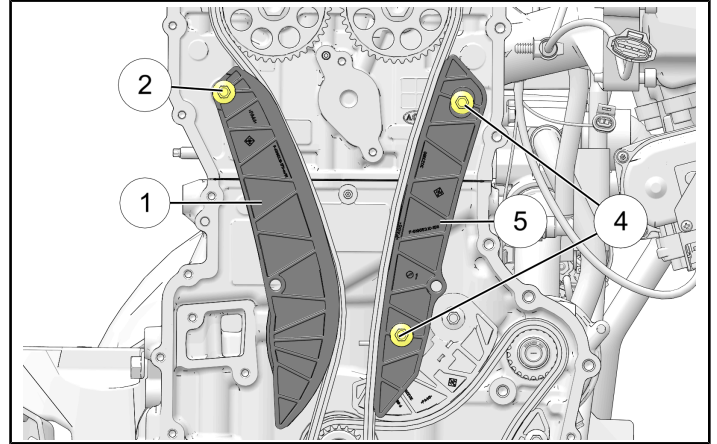

5. Install NEW fixed cam chain guide ⑤. Torque fasteners to specification

TORQUE

Timing Chain Guide Fastener (Fixed):
80 in-lbs (9 N·m)

ADJUSTABLE TIMING CHAIN GUIDE INSTALLATION

1. Assemble the timing chain with indicator marks as shown.

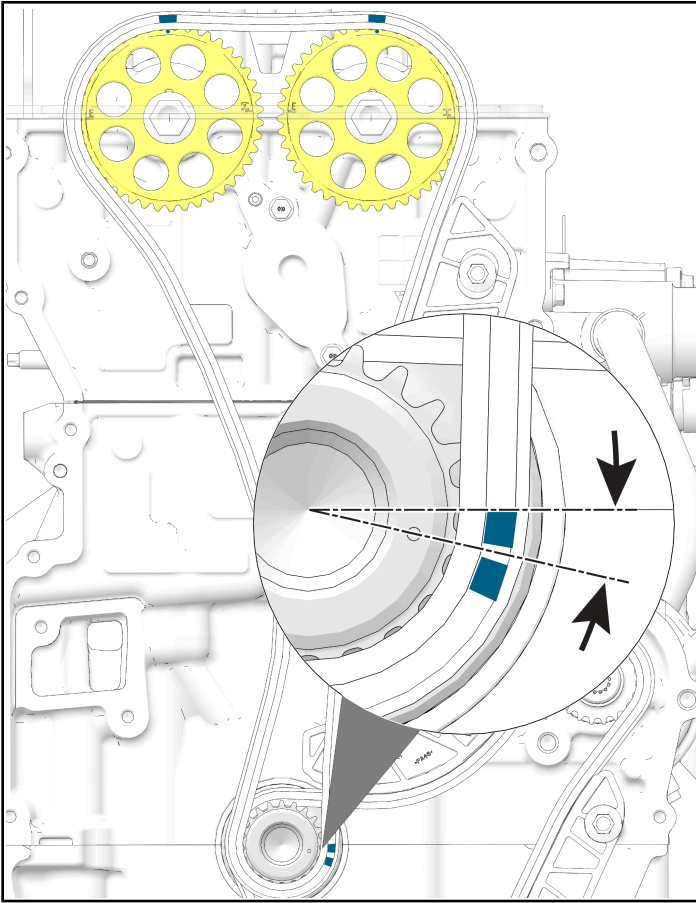

MEASUREMENT

12.7° or approximately the 4 o'clock position

2. Install the timing chain onto the camshaft sprockets matching the colored links to the indicator marks at the 12 o'clock position.
3. With the engine at cylinder 1 top dead center, the indicator mark on the crankshaft should be at the 4 o'clock position. Route the timing chain around the crankshaft sprocket and align crankshaft indicator dot between the colored links in approximately the 4 o'clock position.

4. Install NEW adjustable timing chain guide and install the adjustable timing chain guide fastener ⑩. Torque fastener to specification.

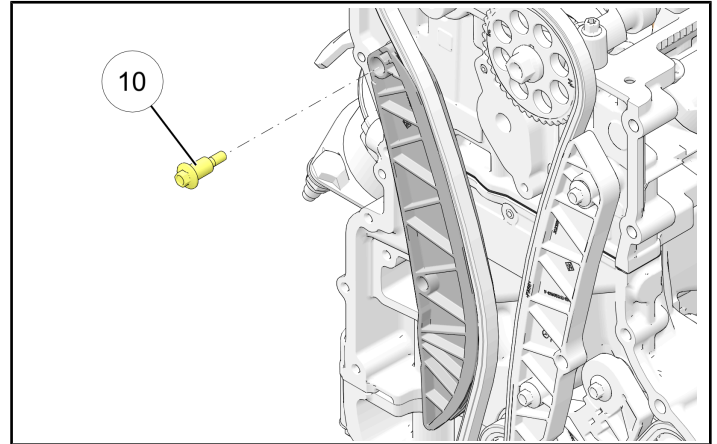

TORQUE

Timing Chain Guide Fastener (Adjustable):
89 in-lbs (10 N·m)

TENSIONER INSTALLATION

Reset the timing chain tensioner by performing the following steps:

1. Remove the piston assembly from the body of the timing chain tensioner.
2. Press in and twist clock-wise the end of the tensioner piston until it engages with itself and stays collapsed.

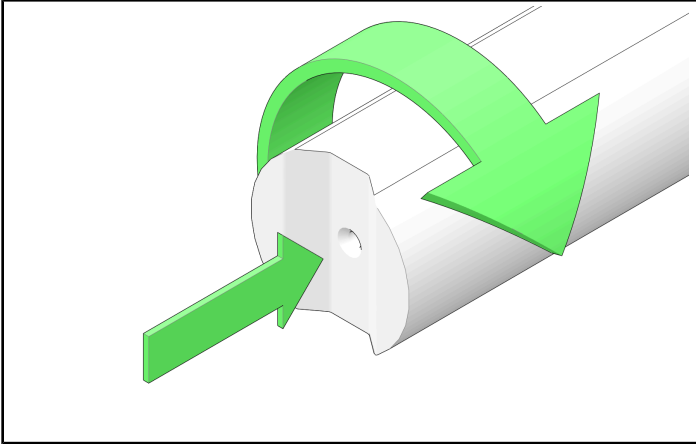

NOTICE

This procedure works best when the tensioner piston is dry.

3. Reinstall the piston assembly into the body of the tensioner.
4. Install the tensioner assembly into the crankcase.
5. Install chain tensioner assembly. Install chain tensioner fasteners ③ and torque to specification.

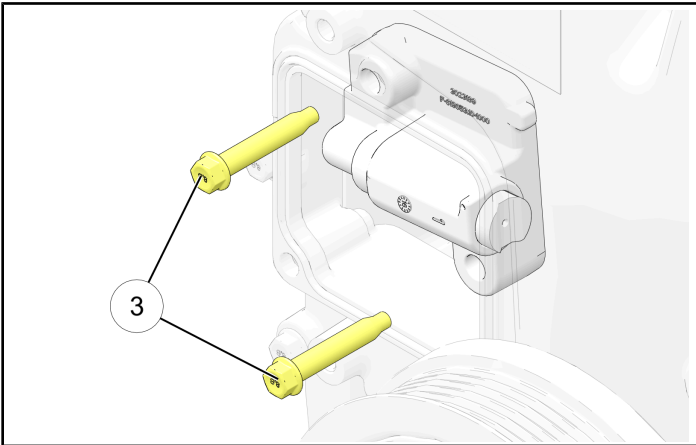

TORQUE

Tensioner Fasteners:
80 in-lbs (9 N·m)

FRONT COVER INSTALLATION

1. Remove and clean the front cover mating surface.
2. Apply Threebond sealant.
3. Install front cover. Loosely install fasteners ⑦, ⑧ and ⑨.

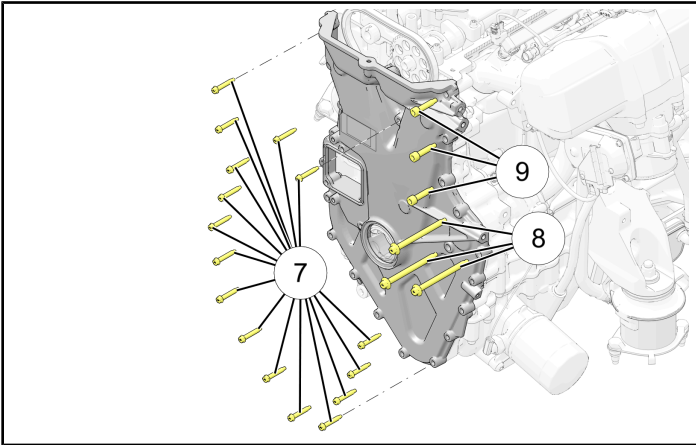

NOTICE

The longer fasteners ⑧ support the water pump. Make sure the pump is seated properly before installing the fasteners.

4. Torque fasteners to specification in sequence shown.

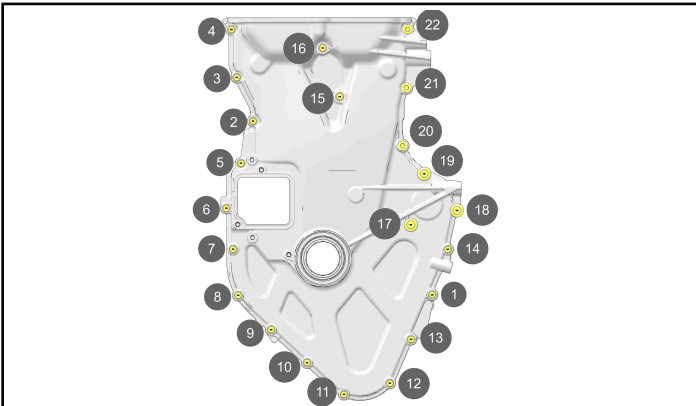

TORQUE

M6 Fasteners (Items 1–16):
80 in-lbs (9 N·m)

TORQUE

M8 Fasteners (Items 17–22):
16 ft-lbs (22 N·m)

CRANKSHAFT HARMONIC DAMPER INSTALLATION

NOTICE

Ensure both components are aligned correctly or serious engine damage will occur.

1. Install the Harmonic Pulley onto the crankshaft.

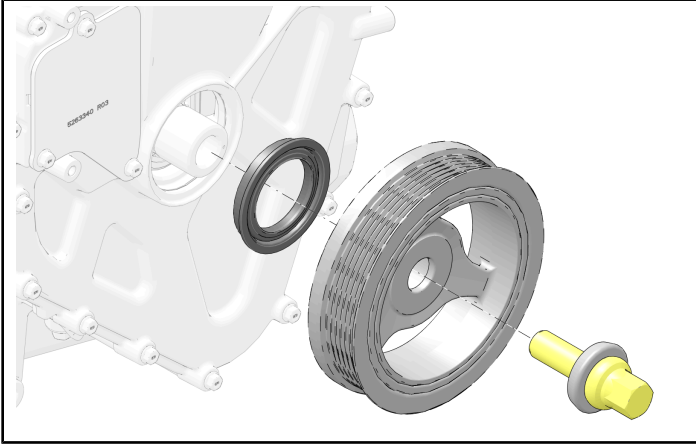

2. Oil the threads and install the retaining fastener. Use the **PU-52810** guide and a breaker bar to prevent the crankshaft from rotating when tightening the fastener. Torque to specification.

TORQUE

Front Harmonic Pulley Fastener:

- a. Torque fastener to 74 ft-lbs (100 N·m)
- b. Loosen fastener 180°
- c. Torque fastener to 22 ft-lbs (30 N·m) + 70°

3. Install the rear radiator shroud and fasteners ④. Torque fasteners to specification.

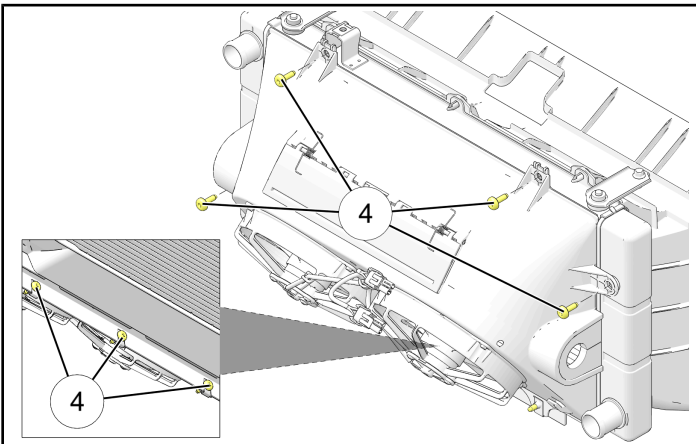

4. Install the lower shroud and push-ribose fasteners.

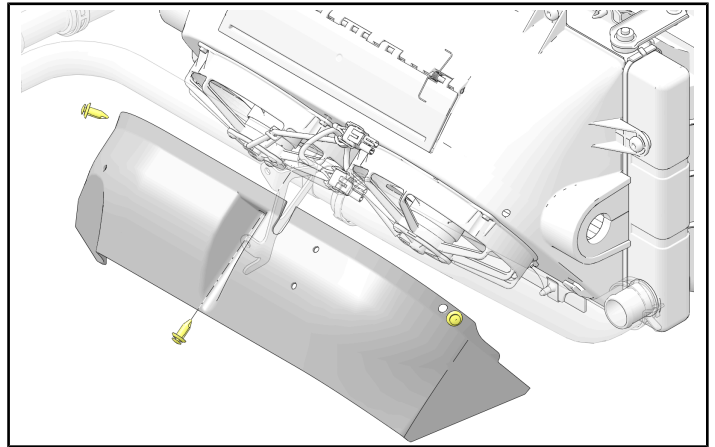

5. Connect the cooling fan electrical connectors ③.

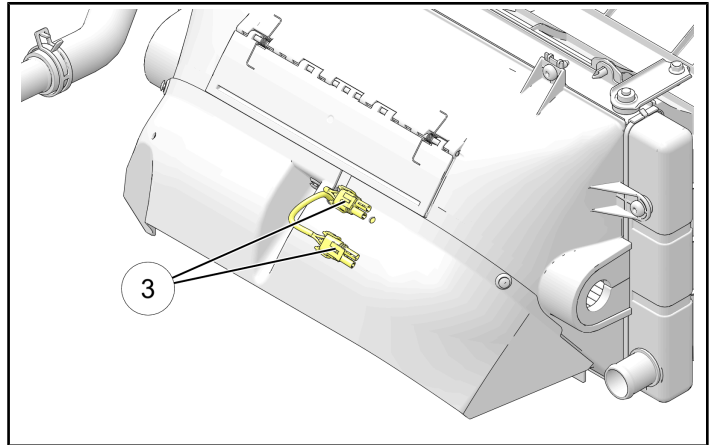

6. Install a NEW stretch belt. Refer to **page** .
7. Install coolant bracket ② and three fasteners ①. Torque to specification

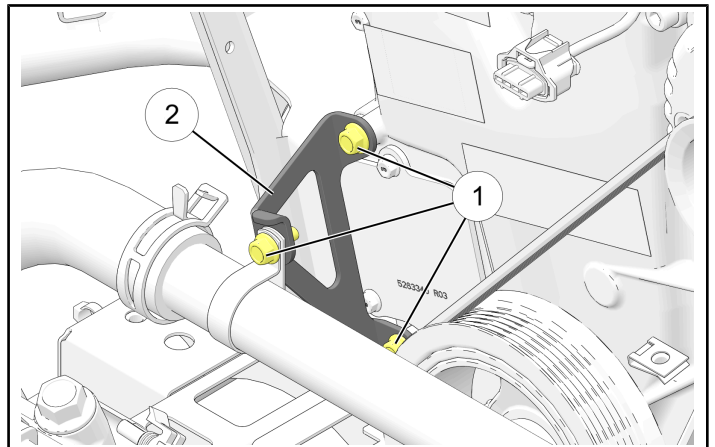

TORQUE

Cooling Line Retention Fasteners:
97 in-lbs (11 N·m)

ALTERNATOR INSTALLATION

1. Install new alternator. Loosely install fasteners ④ and ⑤. Torque fasteners to specification in sequence shown.

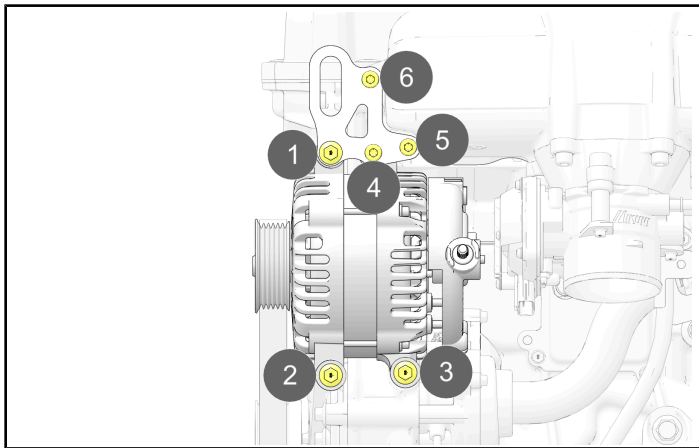
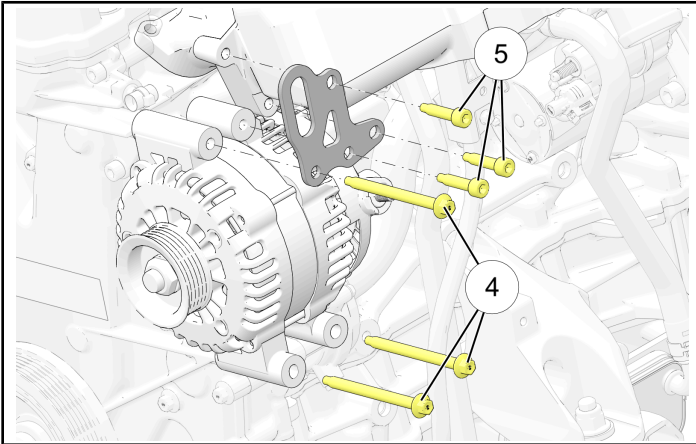

TORQUE

Alternator Mounting Fasteners:
16 ft-lbs (22 N·m)

3. Connect the alternator electrical connector.

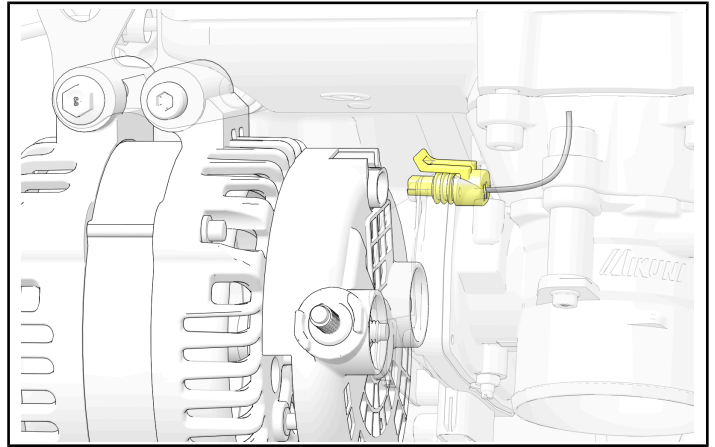

4. Install the main charging lead to the alternator. Install positive terminal nut ③ and torque to specification. Cover the terminal nut with the red protective cap.

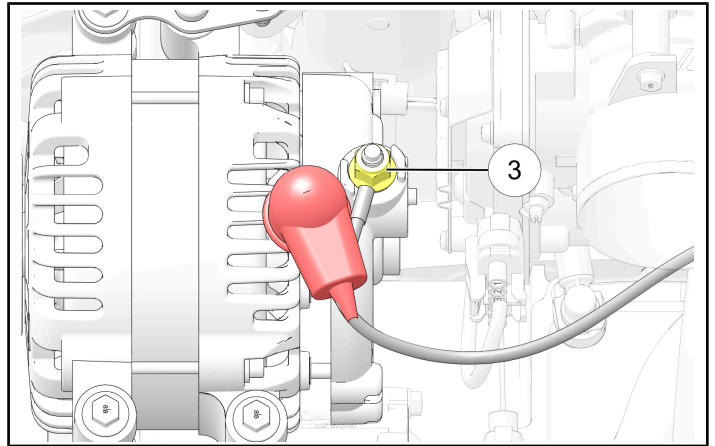

TORQUE

Alternator Terminal Nut:
84 in-lbs (9 N·m)

2. Using a commercially-available stretch belt installation tool, install a NEW stretch belt over the alternator and balance pulleys.

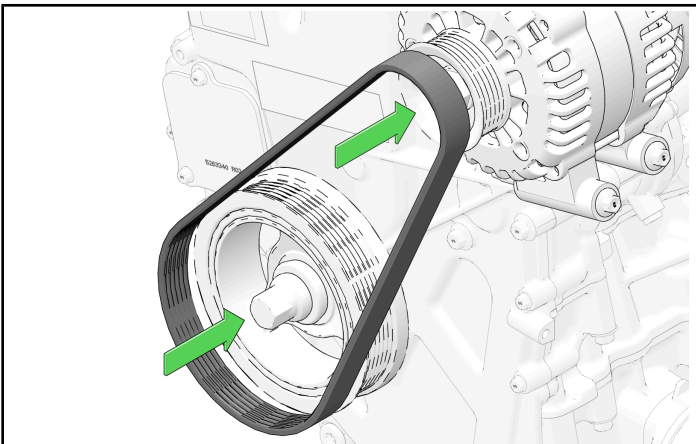

5. Install negative (-) cable to the battery and torque terminal bolt to specification.

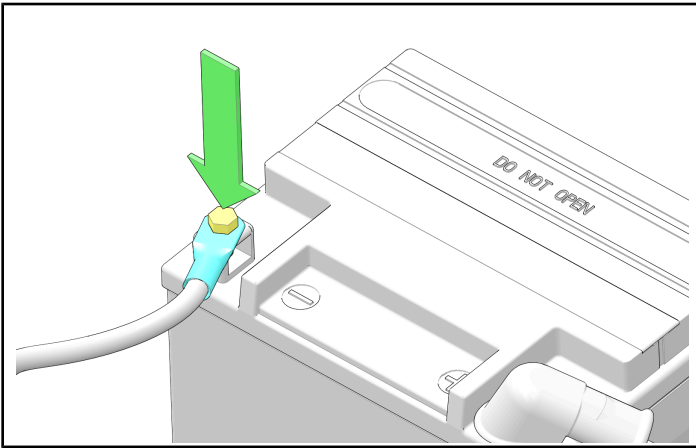

TORQUE

Negative Battery Terminal:
40 in-lbs (4.5 N·m)

6. Install the two fasteners securing the battery cover to the battery bracket.

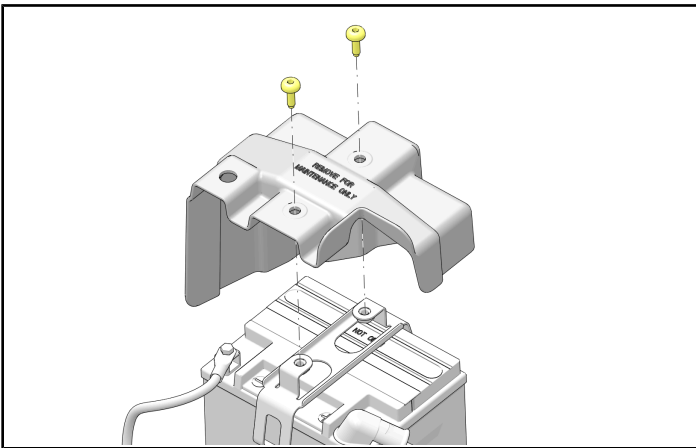

TORQUE

Battery Cover Fasteners:
65 in-lbs (7 N·m)

AIR BOX INSTALLATION

1. Install air box base and fasteners ③. Torque fasteners to specification.

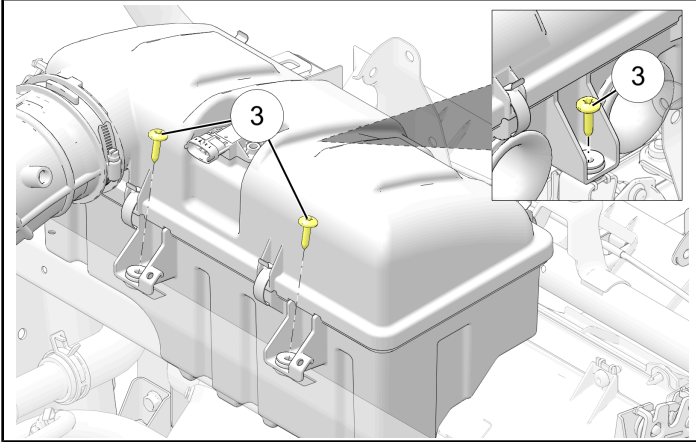

TORQUE

Airbox Fasteners
89 in-lbs (10 N·m)

2. Install the air box cover along with the intake air boot and breather tube. Connect the breather tube ① to the valve cover. Install the intake air boot to the intake manifold. Torque intake duct clamp to specification.

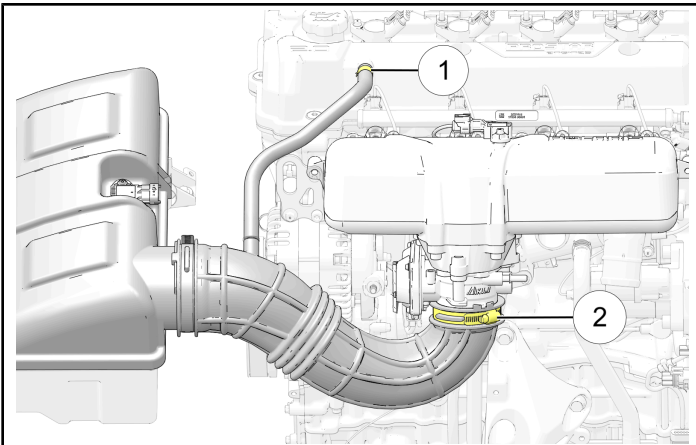

TORQUE

Intake Duct Clamps
35 in-lbs (4 N·m)

3. Connect the TMAP electrical connector to the air box cover.

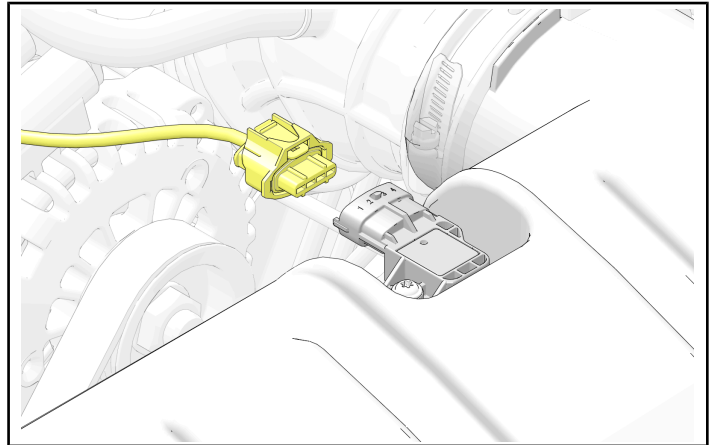

VALVE COVER INSTALLATION

1. Assemble the valve cover and a NEW gasket ⑧ (5814467). Make sure that the gasket is located in the retaining groove in the valve cover.

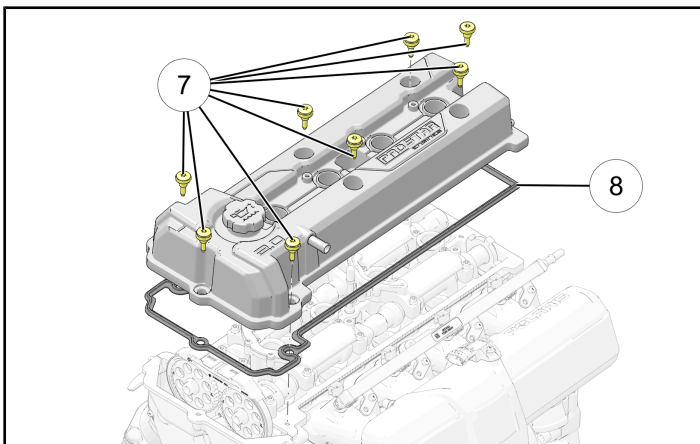

IMPORTANT

Apply liquid engine sealant at the T-Joint

2. Install the cover on the cylinder head and hand start the fasteners ⑦. Using sequence shown, torque fasteners to specification.

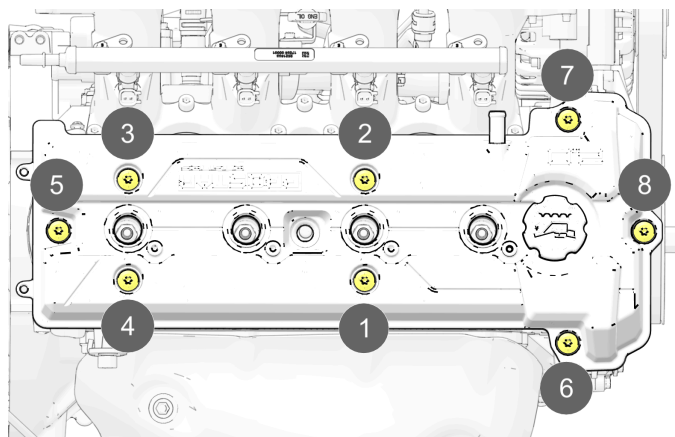

TORQUE

Valve Cover Fasteners:
89 in-lbs (10 N·m)

3. Install new cable ties ⑥ to the valve cover.

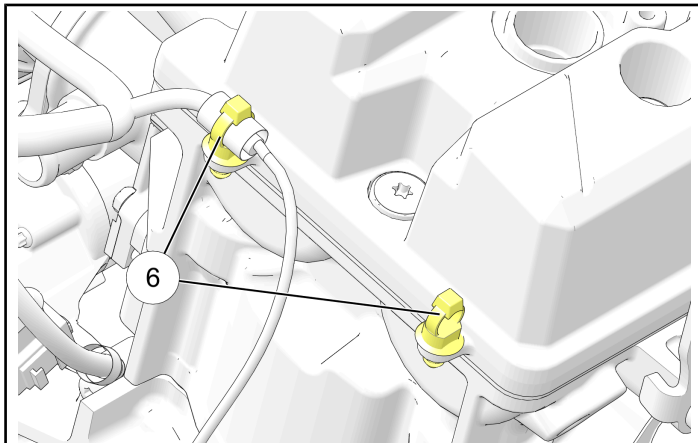

4. Install the ignition coils ⑤.

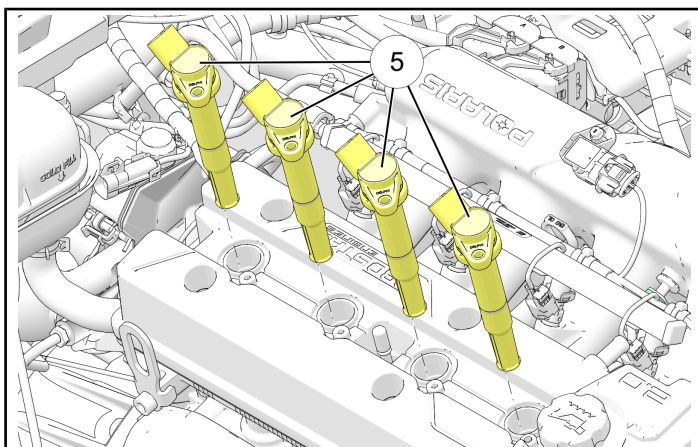

5. Install the ignition coil fasteners ④. Torque to specification

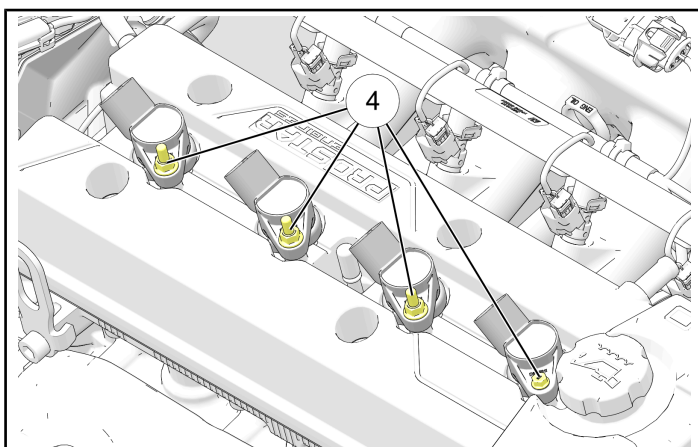

TORQUE

Ignition Coil Retaining Fasteners:
80 in-lbs (9 N·m)

- Connect the spark plug wire connectors ③ to the ignition coils.

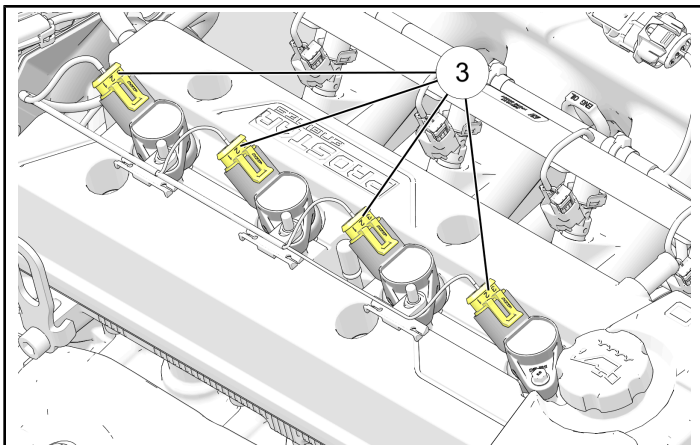

- Connect the breather hose by securing clip ① to the valve cover fitting. Connect the coolant vent line fitting ②.

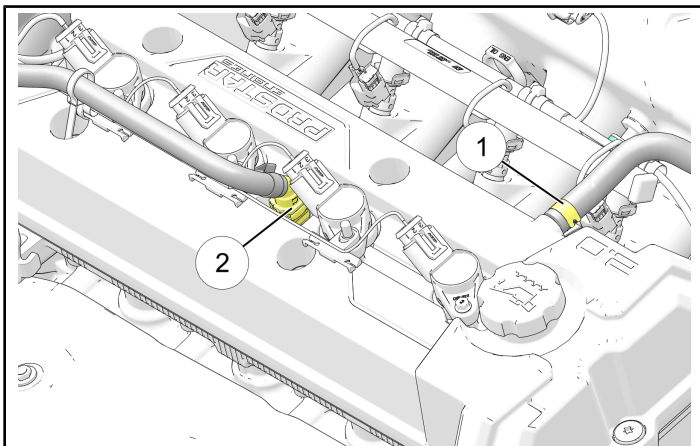

NOTICE

Listen for an audible click when connecting the coolant line fitting and gently pull on the connector to make sure the line is fully connected.

OIL CHANGE

- Clean the area around the drain plug at the bottom of the oil pan.

⚠ WARNING

Personal injury can occur when handling used oil. Hot oil can cause burns or skin damage.

- Place a drain pan beneath the oil pan and remove drain plug ①.
- Remove the crush washer and DISCARD.
- Allow oil to drain completely.

- Using a clean, dry cloth, clean filter sealing surface on crankcase.

NOTICE

The sealing surface on the drain plug should be clean and free of burrs, nicks or scratches.

- Install NEW crush washer onto the drain plug ① and install. Torque to specification.

TORQUE

Oil Drain Plug:
13 ft-lbs (18 N·m)

- Using oil filter socket **PU-52890**, turn the oil filter ② counter-clockwise to remove and discard.

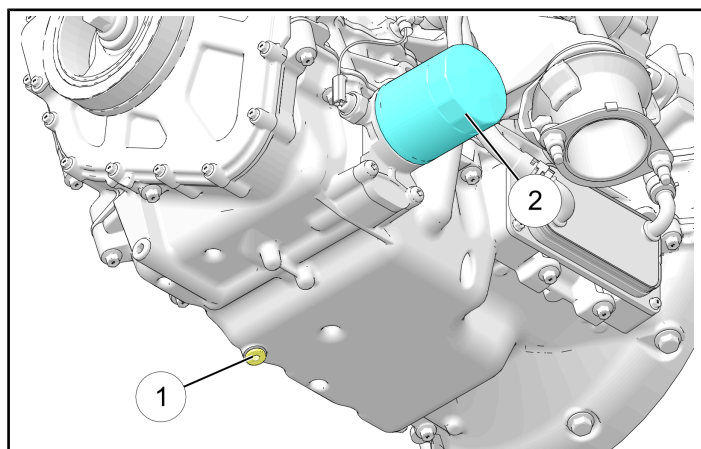

- Lubricate gasket area on new oil filter with a film of fresh engine oil. Check to make sure the sealing areas are in good condition.

- Install a new oil filter and torque to specification.

TORQUE

Oil Filter:
Turn by hand until filter O-ring contacts sealing surface, then turn an additional 3/4 turn.

- Fill the sump with oil to the recommended level through the oil filler access cap ③ on top of the valve cover.

FLUID CAPACITY

**Recommended Engine Oil: Full Synthetic SAE 5W-50
Engine Oil Capacity: 6.0 qt (5.68 L)**

- Place gear selector in neutral.
- Start the engine and let it idle for one to two minutes. Stop the engine and inspect for leaks.

13. Re-check the oil level on the dipstick ④ after three minutes and add oil as necessary to bring the level to the safe zone on the dipstick.

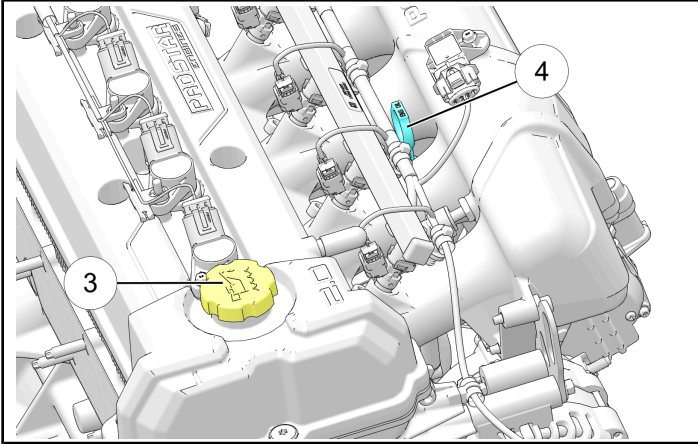

14. Dispose of used oil and oil filter properly.