

Service Bulletin

Service Manual Heading: Braking System		
Models Affected: Enviro 500 North America Only	Title: Spring Brake Chamber Breather	No: 870
Date: May 2014		
Page: 1 of 2		

Introduction

This bulletin has been issued to inform customers of the availability of an actuator by-pass breather kit for Wabco Spring Brake Chambers. Part Numbers 441331 & 440675. These chambers were used on chassis number 1829 onwards and also buses originally fitted with MGM actuators but converted as per Service Bulletin 763-2.

In the event that air systems are not fully charged before attempting to move off the spring brakes may remain lightly applied. The kit has been released to reduce the likelihood of this, and prevent the brake from binding when vehicles are first driven each day. It will also add a level of protection in the event of internal leakage of spring brake which is too slight to be detected during normal maintenance checks.

Kit Details

The kit is listed under ADL Part Number 660883-2. Check availability with your local Parts Centre.



WARNING

ENSURE THAT AIR PRESSURE IS EXHAUSTED FROM THE BRAKE SYSTEM BEFORE ATTEMPTING TO FIT BREATHER KIT. THE WORK MUST BE CARRIED OUT BY QUALIFIED WORKSHOP PERSONNEL.

Instructions

Refer to fig 1.

1. Remove all dirt deposits on the brake chamber in the area where breather is to be fitted.
2. Remove and discard the plug (item 1) from rear of chamber.
3. Assemble washer (item 3) onto adapter (item 2).
4. Screw assembled adapter into hole where plug was removed from. Tighten to 7 ± 1 Nm.
5. Push breather pipe (item 5) secured with clip (item 4) onto adapter (item 3).
6. Secure breather in place on side of chamber using strap (item 6). Tighten to 0.5 ± 0.1 Nm
7. Fit breather to other spring brake chamber following instructions.
8. Charge air brake system and check brake function correctly before returning vehicle to service.

Service Manual Heading:		Braking System	
Models Affected: Enviro 500 North America Only		Title: Spring Brake Chamber Breather	No: 870
Date:	May 2014		
Page:	2 of 2		

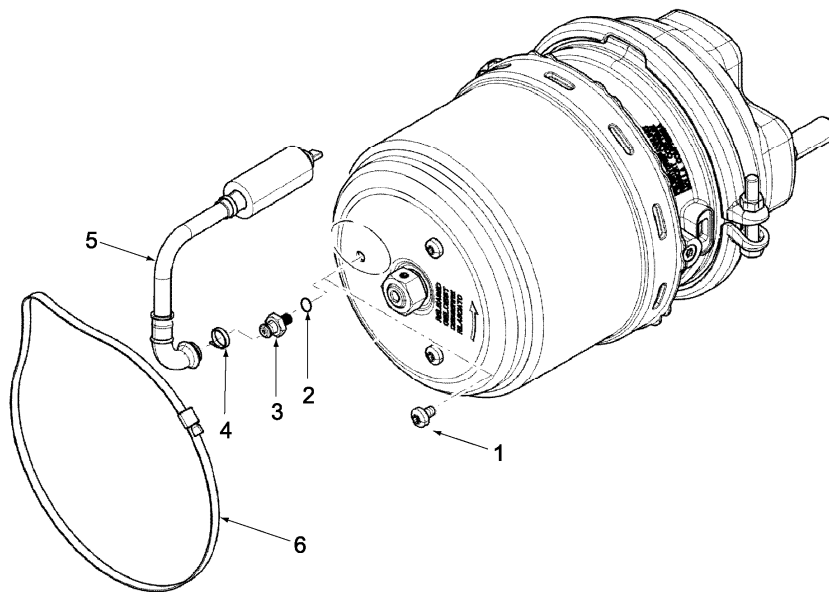

Fig 1. Breather Kit

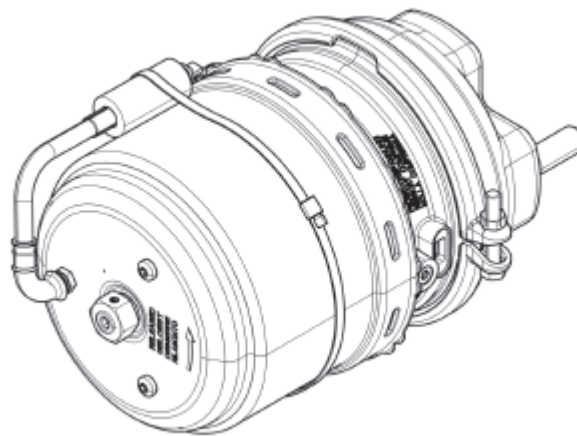

Fig 2. Fitted Breather in Position

Alexander Dennis
 Dennis Way, Guildford,
 Surrey, GU1 1AF.
 After Market Support Line:
 0845 358 9988 (U.K.)
 +44 (0) 1483 571271



Service Bulletin

Service Manual Heading: Braking			
Models Affected: Enviro 500 L.H.D. N. America Only	Title: Replacement Brake Actuator	No: 763-2	
Date: Mar 2007			
Page: 1/9			

This bulletin has been re-issued to inform operators that MGM type brake actuators are no longer available. If a vehicle fitted with MGM type actuators requires a replacement actuator, then kit no SL2099 must be used. Check with Alexander Dennis Parts for availability. Trident 3's are not affected as stated on previous Service Bulletin 763.

The kit facilitates the fitting of Wabco 30/30 type actuators in place of the previous MGM units. The kit contains all necessary parts to install the Wabco actuators on both the drive and auxiliary axle.

Important Note: MGM and Wabco actuators must not be mixed on a vehicle and it is essential that if an original MGM actuator is being replaced with a Wabco unit, all 4 actuators on drive and auxiliary axles are changed and that the modifications are carried out to the air brake system to maintain vehicle road legality.

SL2099 Content

Item	Part Number	Qty	Description	Fitting Position
1	439953	4	Packer Suspension	Under air spring piston
2	MCB-112-65P	4	Bolt M12 x 65	Suspension piston to beam
3	WMC-16P	8	Washer Spring M16	Actuator mounting studs
4	661080	2	Adaptor Elbow M/F M22	In quick release valve
5	440676	1	Mount Actuator LH	Drive axle RH
6	440677	1	Mount Actuator RH	Drive axle LH
7	MFN-216P	4	Half Nut M16	Actuator pushrods
8	654923-1	1	Tee Piece	In place of bracketed tee
9	657240	1	Elbow 90 deg M/F	Port In quick release valve
10	658400-4	1	Connector Straight	In end of ABS DC Valve
11	609873	6	Tube 3/8 Nylon Yellow	Between DC valve & QRV
12	441331	2	Actuator	Drive axle
13	440675	2	Actuator	Tag axle
14	442163	2	Plate ABS Valve	Moves valve down
15	MCS-108-25P	8	Setscrew M8 x 25	Plate to frame
16	MCN-508P	8	Nut Self Locking	Plate to frame
17	654931	2	Adaptor M22 / M16	In ABS valve
18	661052	2	Quick Release Valve	Connected to ABS valve
19	612747	2	Plug M16	In QRV port
20	659280	2	Silencer Air System	On QRV's

Service Manual Heading: Braking

Models Affected:
Enviro 500
L.H.D. N. America Only

Title:
Replacement Brake
Actuator

No:
763-2

Date: Mar 2007

Page: 2/9

Instructions

1. Ensure that the all appropriate safety measures are observed while working on the vehicle & ensure that adequate height is available before raising the vehicle and supporting the vehicle on stands. Ensure that all air pressure is exhausted from brake and suspension system before commencing work.
2. While supporting the drive axle, slacken and remove the air suspension spring lower mounting bolts. Insert the Packer (item 1) between the suspension plate and the air spring suspension piston. Secure in position using bolts (item 2).

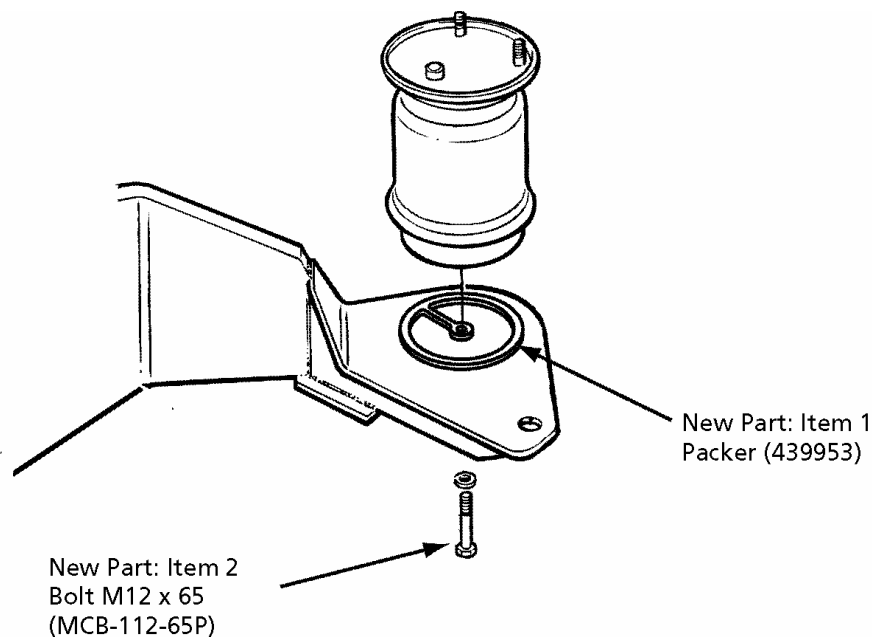

3. Disconnect air line connections at rear actuators. Remove clevis pin from actuating arms. Slacken and remove actuator mounting nuts and remove actuators from mounting brackets. On the drive axle only remove the actuator mounting brackets.
4. Mount new actuator mounting brackets (item 5) left hand and (item 6) right hand onto the drive axle.
5. Loosen outer locknut on slack adjuster control arm brackets (View A). Ensure that a second spanner is used to hold the inner locknut in position. It is vital that no side loading is placed on the arm. Repeat this operation for slack adjusters on Tag and drive axles.

Service Manual Heading: Braking		
Models Affected: Enviro 500 L.H.D. N. America Only	Title: Replacement Brake Actuator	No: 763-2
Date: Mar 2007		
Page: 3/9		

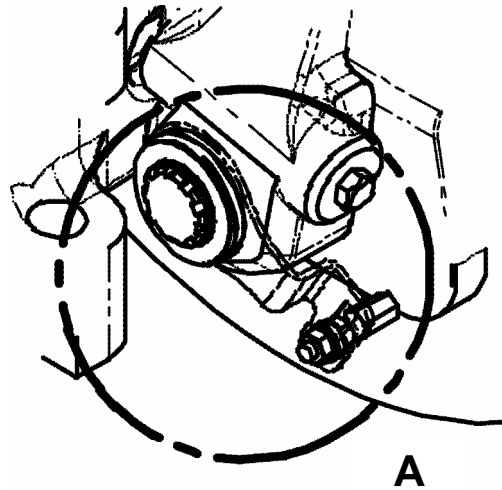

6. Fit a half nut (item 7) to the actuator pushrod, then fit clevis and adjust so that rod end is approximately level with the inside face of the clevis. This should give a dimension of 76mm from the centre of the clevis mounting hole to the mounting face of the actuator. (View B). Tighten half nut to lock clevis in this position. Repeat this operation for all replacement actuators.

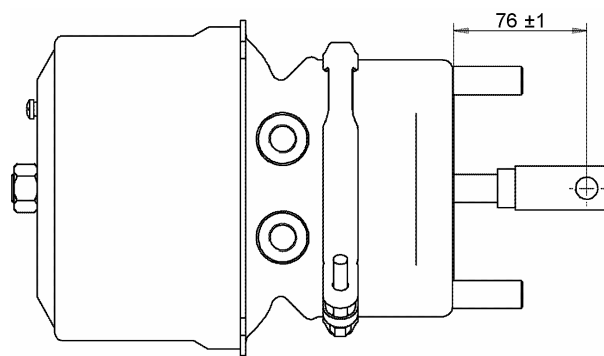

7. Bolt the actuator to the mounting bracket. (Item 12) drive axle, (item 11) tag axle. Ensure that the yoke hole is centred on the slack adjuster hole. If not, the position of the slack adjuster should be altered by turning the adjuster hex one or two clicks until the holes coincide.

Service Manual Heading:

Braking

Models Affected:

Enviro 500
L.H.D. N. America Only

Title:

Replacement Brake
Actuator

No:

763-2

Date:

Mar 2007

Page:

4/9

8. When the hole is correctly aligned assemble as shown in (View C). Repeat operation for remaining actuators.

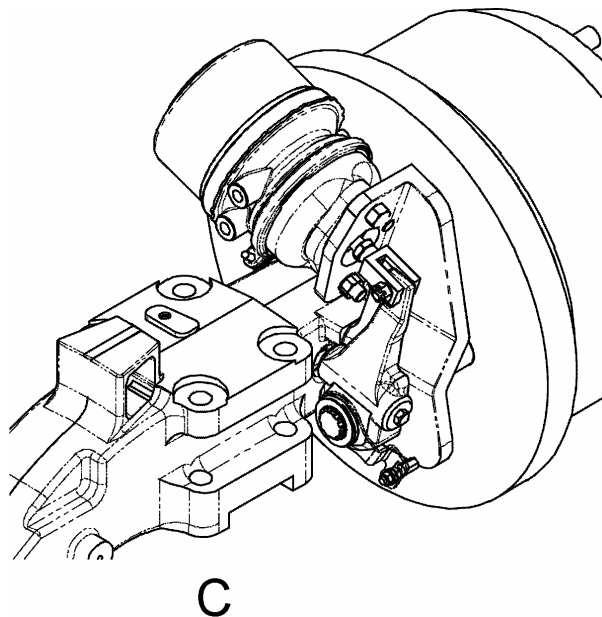

9. After tightening clevis pin nut secure with split pin. Push the control arm bracket as far downwards as possible before retightening the outer locknut. Hold inner locknut with a spanner to prevent twisting of the control arm.
10. Remove air fittings shown in Air Brake System - Before modification diagram. Relocate Quick release valve to under stairs outrigger position. Fit items (8 Tee), (9 Elbow) and (10 Connector) as shown in the Air Brake System - After modification diagram and pipe as shown in diagram.

The new actuators are internal breathing actuators, the clear breather tube from the old actuators that was connected to the Quick Release Valve should be removed. Cut a short length of this breather pipe and use it to connect the QRV breather stubs together in a loop to prevent the ingress of dirt into the valve.

Service Manual Heading:

Braking

Models Affected:

Enviro 500
L.H.D. N. America Only

Title:

Replacement Brake
Actuator

No:

763-2

Date:

Mar 2007

Page:

5/9

QUICK RELEASE VALVE POSITION, SEE PHOTO.

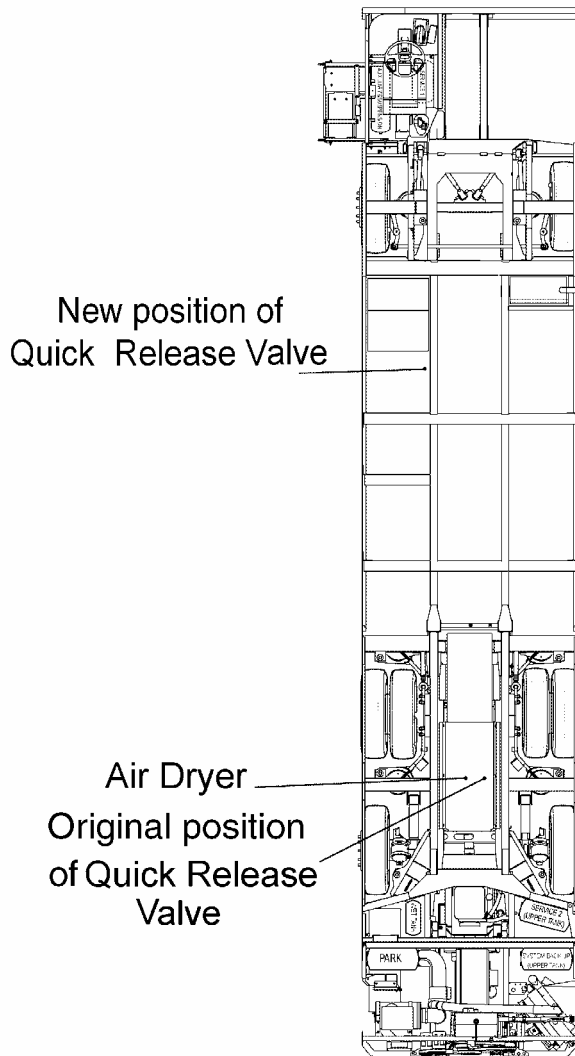

Service Manual Heading: Braking

Models Affected:
Enviro 500
L.H.D. N. America Only

Title:
Replacement Brake
Actuator

No:
763-2

Date: Mar 2007

Page: 6/9

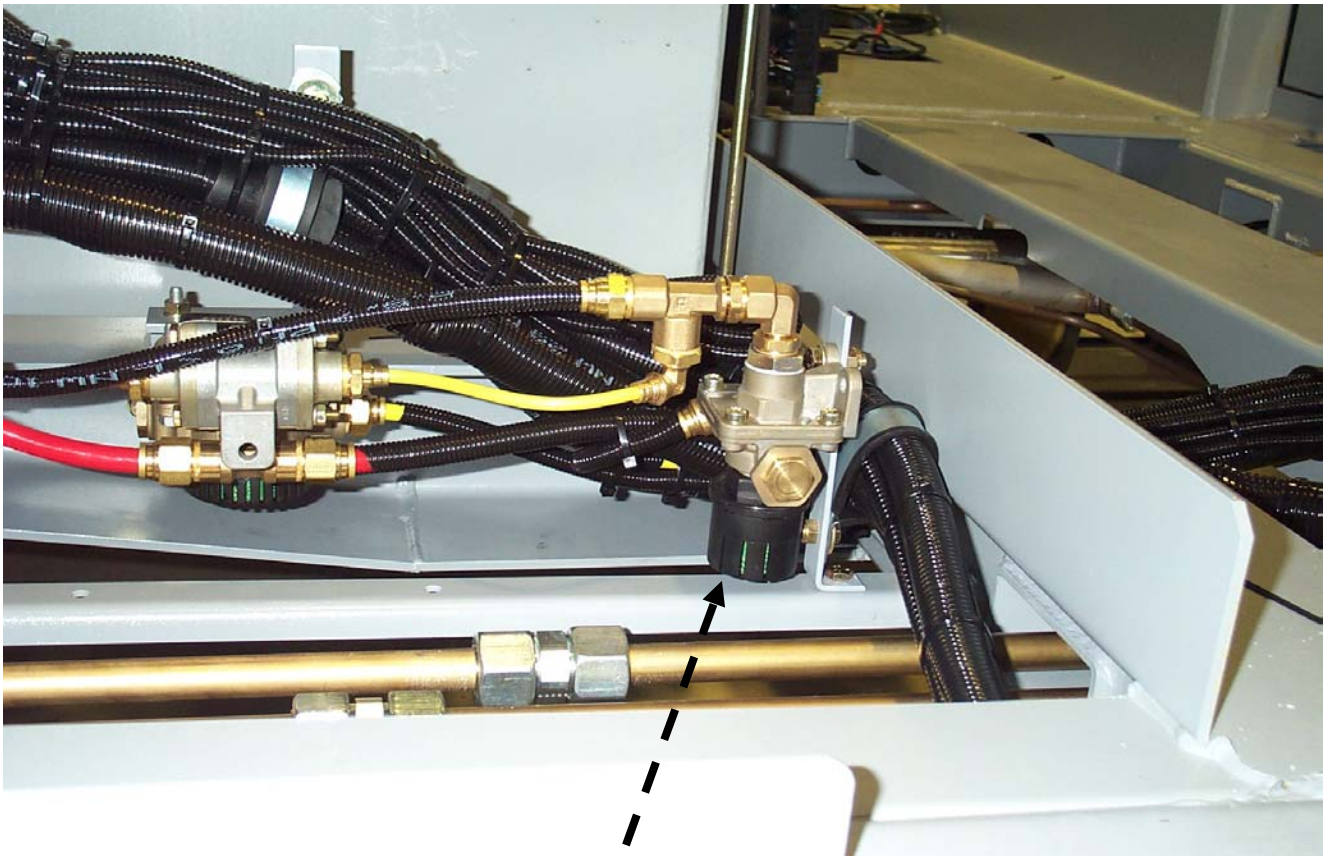

Relocate Quick Release Valve to under stairs outrigger position.

Models Affected:

Enviro 500
L.H.D. N. America Only

Title:

Replacement Brake
Actuator

No:

763-2

Date:

Mar 2007

Page:

8/9

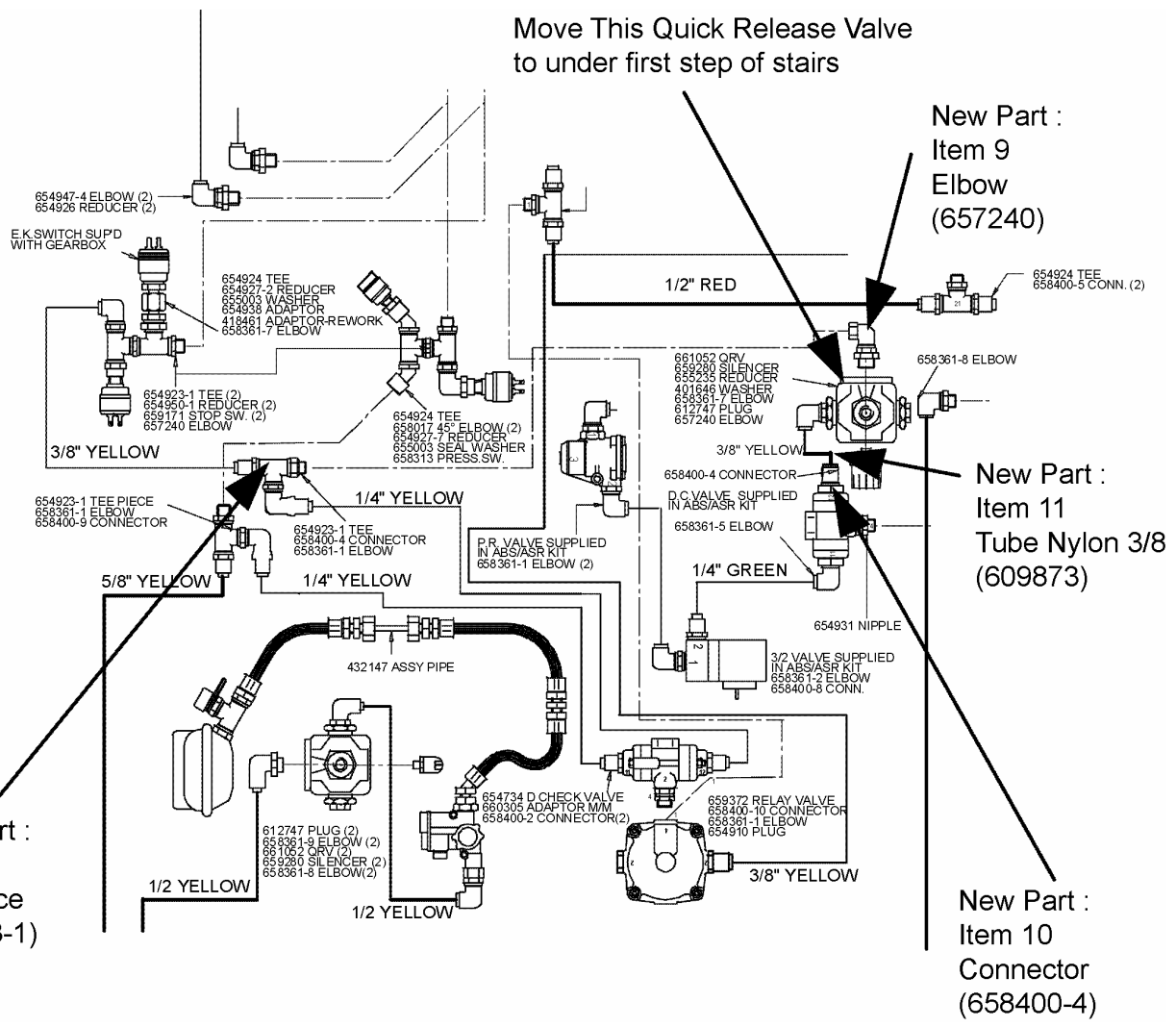

Air Brake System - After Modification

Models Affected:
 Enviro 500
 L.H.D. N. America Only

Title:
 Replacement Brake
 Actuator

No:
763-2

Date: Mar 2007

Page: 9/9

11. Fit components from the kit in the positions shown in the diagram below. After completion ensure all connections are secure. Charge air system to operating pressure, with vehicle stationary, operate the brakes ensure that no leaks are present.

