



# TECHNICAL SERVICE BULLETIN

## Moan Noise In The Rear Brakes When Vehicle Is Driven In Reverse In Cold Weather And/Or High Humidity

**25-2051**

17 February  
2025

This bulletin supersedes 25-2031. Reason for update: update the parts list.

### Model:

<b>Ford</b> 2021-2025 Bronco Sport	Built on or before 21-Dec-2024
2020-2025 Escape	

**Markets:** North American markets only

**Issue:** Some of the vehicles listed in the Model statement above may exhibit a moan noise when the vehicle is driven in R in cold weather and/or high humidity. This may be due to the suspension sensitivity of the vehicle.

**Action:** For vehicles that meet all of the criteria in the Issue and Model statements, follow the Service Procedure to install brake pads with clips and if necessary, install the rear reinforced caliper bushings.

### Parts

Service Part Number	Claim Quantity	Package Order Quantity	Number in Package	Description	Note
SZ6Z-2200-A	1	1	1	Brake Pad Kit With Clips	
W720472-S439	1	1	4	Brake Caliper Anchor Plate Bolts	
XG-3-A	1	1	1	Motorcraft® Silicone Brake Caliper Grease And Dielectric Compound	
PM-4-A	1	1	1	Motorcraft Metal Brake Parts Cleaner	Low VOC Compliant Formula
CPM-4-A	1	1	1	Motorcraft® Brake Parts Cleaner	Low VOC Compliant Formula (Canada Only)
PM-4-B	1	1	1	Motorcraft® Metal Brake Parts Cleaner	High VOC Compliant Formula (All Markets Not Requiring A Low VOC Product)

### Parts - Parts To Inspect And Replace Only If Necessary

Service Part Number	Claim Quantity	Package Order Quantity	Number in Package	Description	Note
DG9Z-2C150-B	Only If Necessary (Up To 2)	Only If Necessary (Up To 2)	1	Rear Reinforced Bushing Kit	(2021-2025 Bronco Sport/2020-2025 Escape)
DG9Z-2B486-B	Only If Necessary (Up To 2)	Only If Necessary (Up To 2)	1	Brake Caliper Spring	
LX6Z-2C026-D	Only If Necessary (Up To 2)	Only If Necessary (Up To 2)	1	Rear Brake Disc	

**Claim Quantity** refers to the total number of individual pieces required to repair the vehicle.

**Package Order Quantity** refers to the amount of the service part number package(s) required to repair the vehicle.

**Number In Package** refers to the number of individual pieces included in a service part number package.

**Only If Necessary** indicates the part is not mandatory. Refer to the Service Procedure to determine the inspection/inclusion criteria.

**Warranty Status:** Eligible under provisions of New Vehicle Limited Warranty (NVLW)/Service Part Warranty (SPW)/Service Part New Vehicle (SPNV)/Extended Service Plan (ESP) coverage. Limits/policies/prior approvals are not altered by a TSB. NVLW/SPW/SPNV/ESP coverage limits are determined by the identified causal part and verified using the OASIS part coverage tool.

### Labor Times

Description	Operation No.	Time
2020-2025 Escape, 2021-2025 Bronco Sport: Replace The Brake Pads On Both (2) Rear Brake Calipers Following The Service Procedure Includes Time To Clean Bushing Housing And Add Grease (Can Be Claimed With Operation C, D, E, Or F) (Do Not Use With Any Other Labor Operations Outside Of This Article)	252051A	0.9 Hrs.
2020-2025 Escape, 2021-2025 Bronco Sport: Replace The Caliper Bushings, Guide Pins And Brake Pads On Both (2) Rear Brake Calipers Following The Service Procedure Includes Time To Clean Bushing Housing And Add Grease (Can Be Claimed With Operation C, D, E, Or F) (Do Not Use With Any Other Labor Operations Outside Of This Article)	252051B	1.4 Hrs.
2020-2025 Escape: Additional Time To Machine Both Rear Disc Brake Rotors On Vehicle (Can Be Claimed With Operation A Or B)	252051C	0.6 Hrs.
2020-2025 Escape: Additional Time To Replace Both Rear Disc Brake Rotors (Can Be Claimed With Operation A Or B)	252051D	0.2 Hrs.
2021-2025 Bronco Sport: Additional Time To Machine Both Rear Disc Brake Rotors On Vehicle (Can Be Claimed With Operation A Or B)	252051E	0.7 Hrs.
2021-2025 Bronco Sport: Additional Time To Replace Both Rear Disc Brake Rotors 0.4 (Can Be Claimed With Operation A Or B)	252051F	0.4 Hrs.

### Repair/Claim Coding

Causal Part:	2C150
Condition Code:	42

## Service Procedure

[Bronco Sport Moan Noise](#)

[Escape Moan Noise](#)

**NOTE: 2021-2022 Bronco Sport vehicles built on or before 23-Sep-2022 and 2020-2022 Escape vehicles built on 1-Nov-2020 and through 29-Aug-2022 are not equipped with rear reinforced bushings. Perform the replacement of the rear caliper bushings only for the vehicles that are not equipped with reinforced bushings. Review the warranty history of the VIN and confirm if the rear reinforced bushings were replaced by a previous service bulletin. To review the warranty history, enter the PTS. Enter the VIN. Click for the full warranty repair history.**

1. Proceed to the appropriate procedure based on how the vehicle is equipped.

(1). If the vehicle is not equipped with rear reinforced bushings, complete Procedure A.

(2). If the vehicle is equipped with rear reinforced bushings or if the vehicle recently has installed the rear reinforced bushings by a previous service bulletin, complete Procedure B.

## Procedure A: Installation Of Rear Reinforced Bushings And Brake Pads With Clips

**NOTE: Perform the following procedure on both rear calipers.**

1. Activate the brake service mode. Refer to the WSM, Section 206-00 Brake System > General Information > General Procedures.
2. Remove the wheel and tire. Refer to the WSM, Section 204-04A Wheels and Tires > Removal and Installation.
3. Remove the brake caliper spring. (Figure 1)

Figure 1

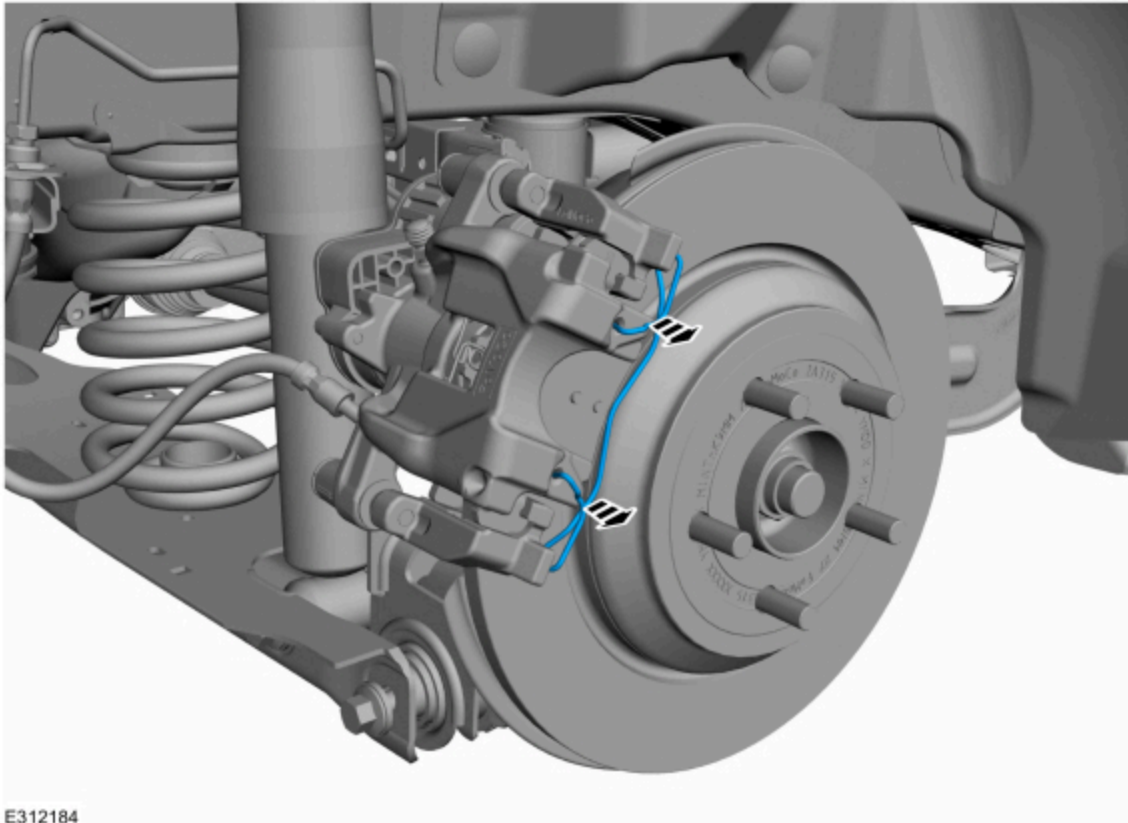

4. Disconnect the parking brake electrical connector. (Figure 2)

Figure 2

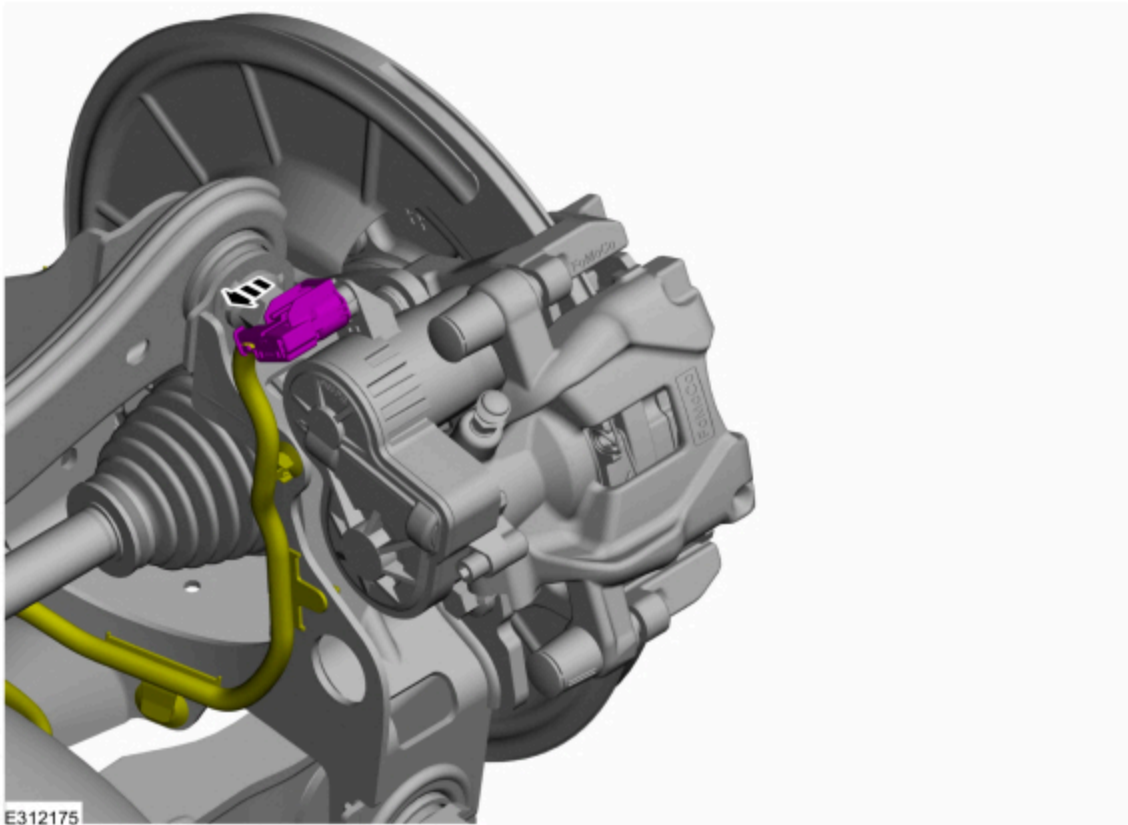

5. Remove and discard the brake caliper guide pin cap and guide pin on the opposite side of the bleeder. (Figures 3-5)

Figure 3

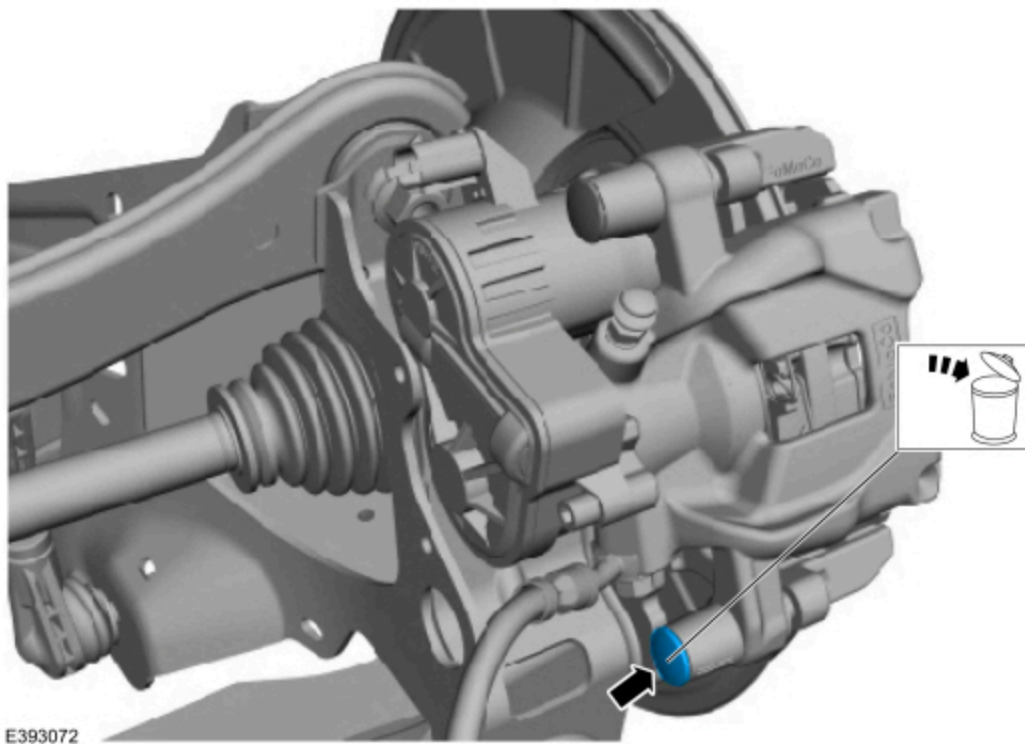

Figure 4



E393073

Figure 5



6. Loosen the upper guide pin and rotate the rear caliper upwards to access to the bushing housing. (Figure 6, Callout 1)

Figure 6

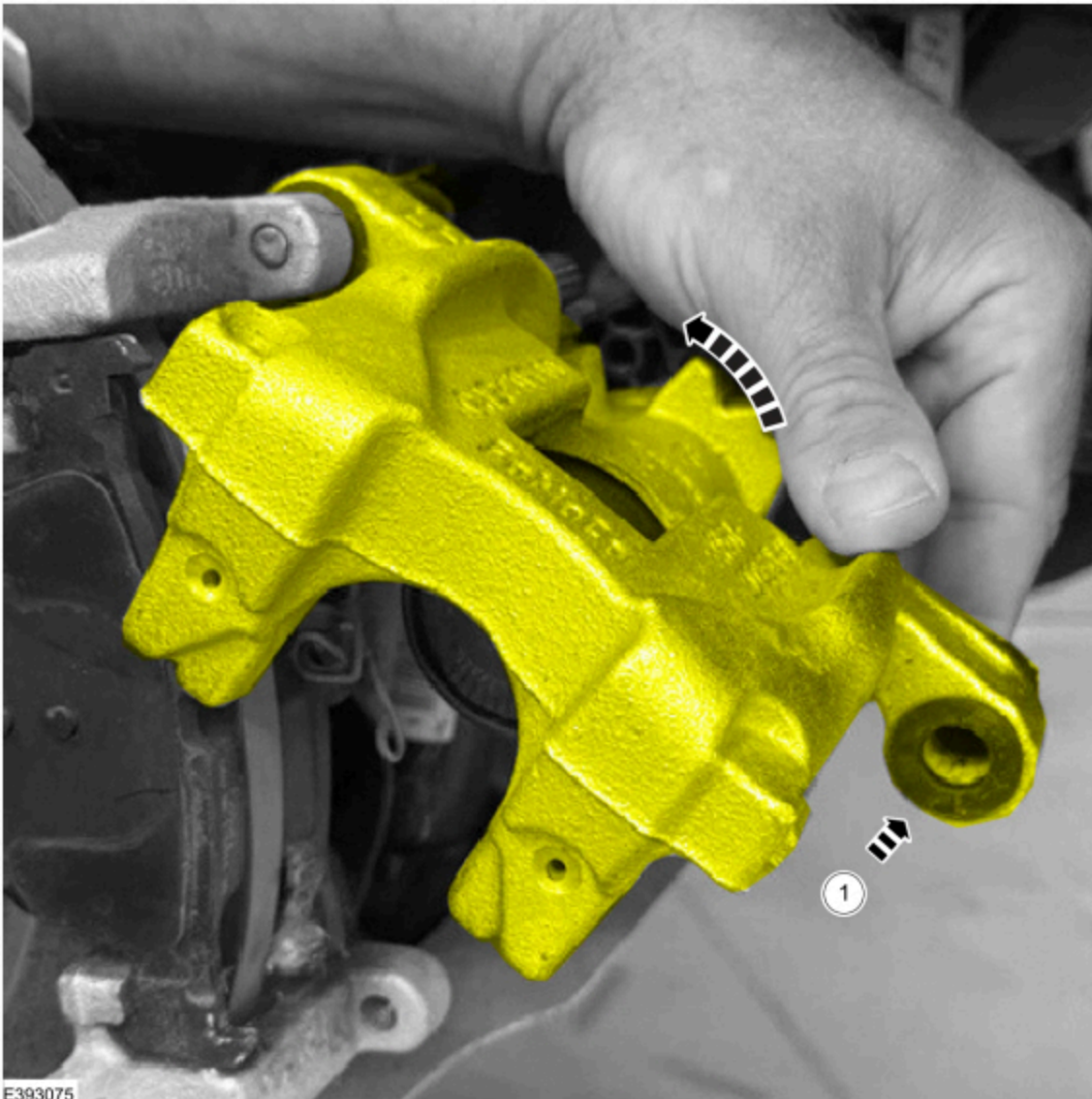

7. Using 6 inch slip joint pliers, remove and discard the standard bushing located on the opposite side of the bleeder.  
(Figure 7)

Figure 7

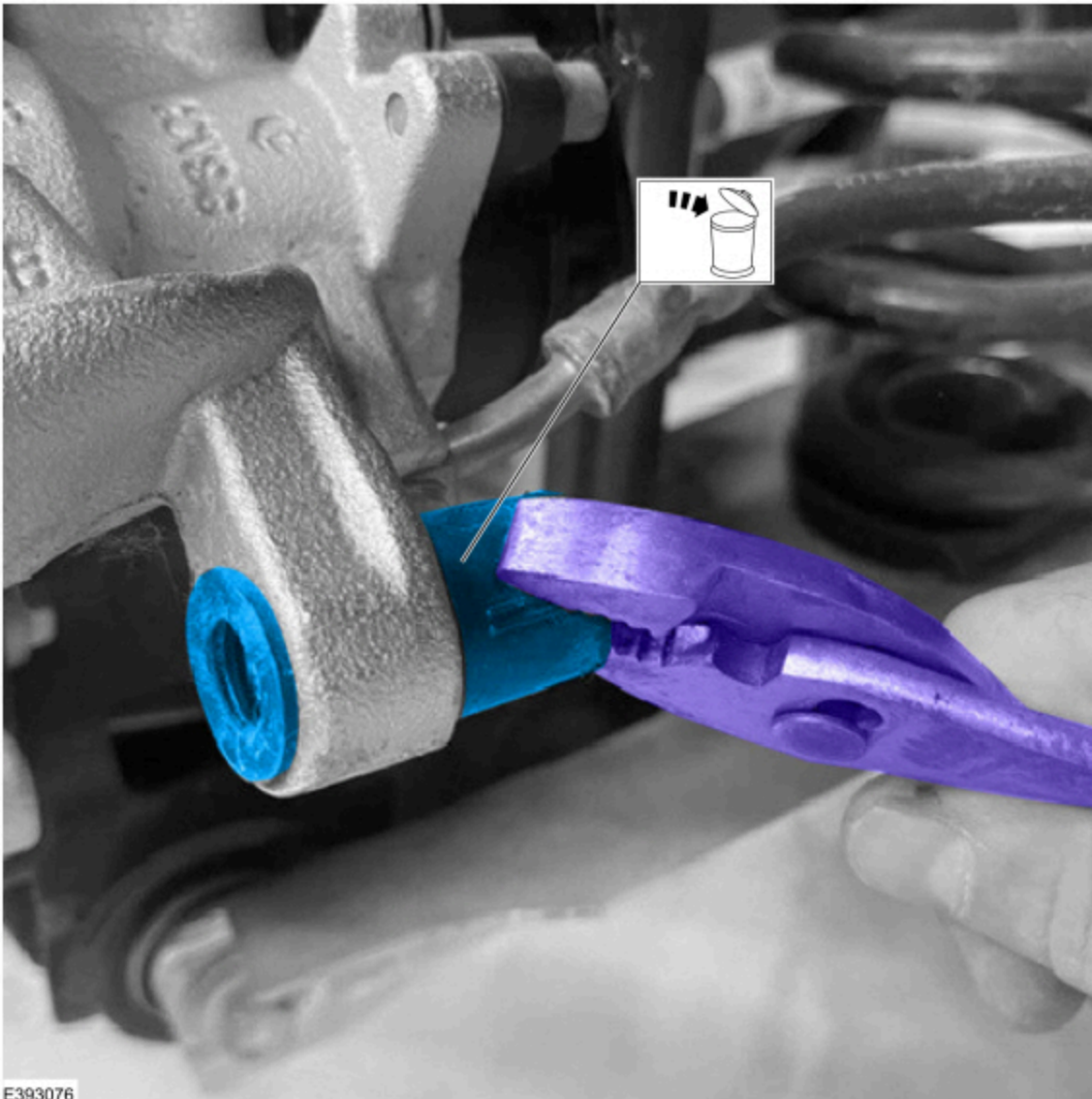

8. Install a new reinforced caliper bushing.

**NOTE:** The kit includes: (1) standard bushing (Figure 8, Callout 1), (1) reinforced bushing (Figure 8, Callout 2), (2) guide pins (Figure 8, Callout 3), (2) guide pin caps (Figure 8, Callout 4)

Figure 8



E441792

Item	Description
1	Standard Bushing
2	Reinforced Bushing
3	Guide Pins
4	Guide Pin Caps

(1). Use a ½ inch drum sander bit to clean the caliper bushing housing. (Figure 9)

Figure 9

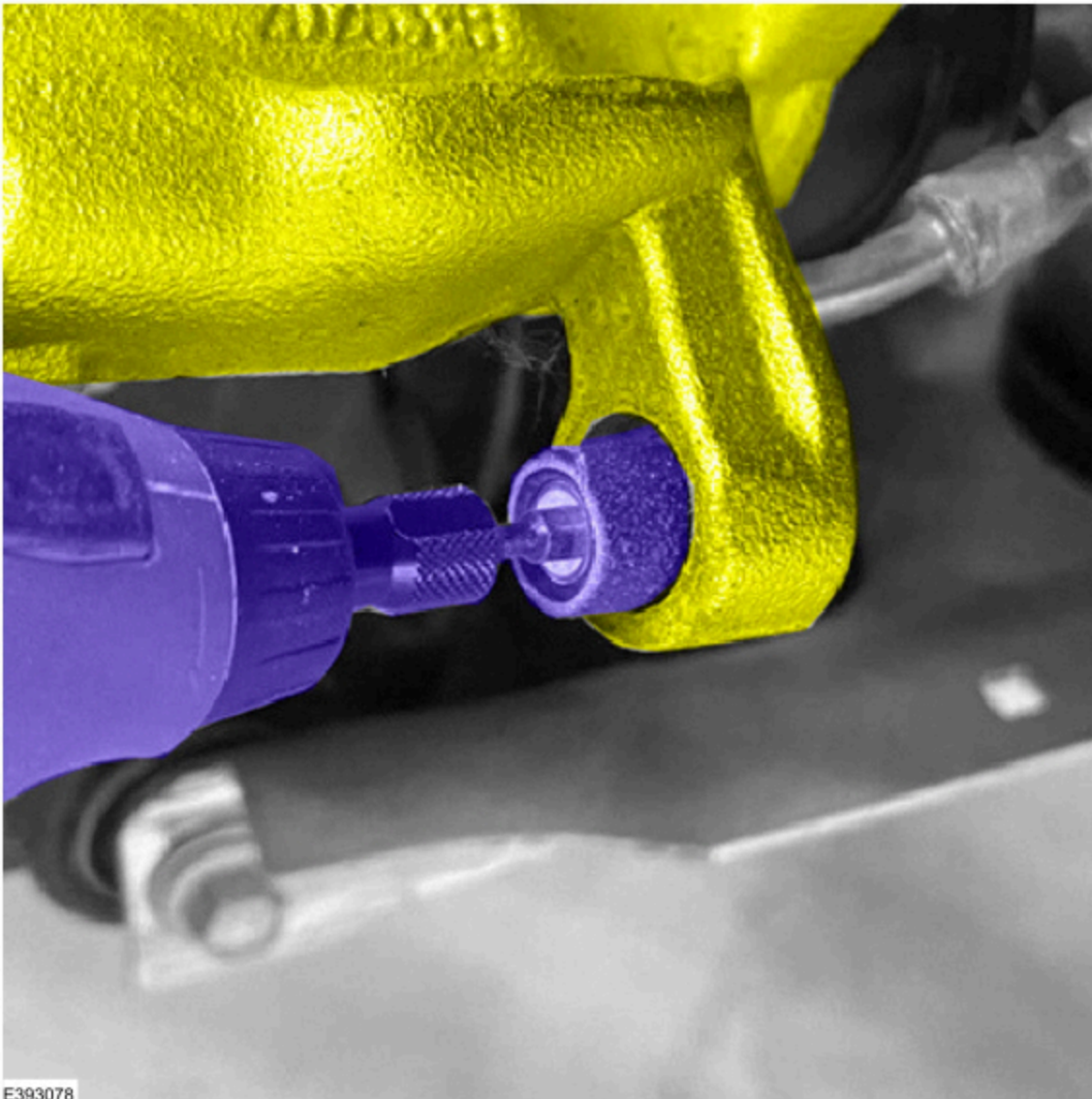

(2). Use Motorcraft® Metal Brake Parts Cleaner to remove any brake dust from the bushing housing.

(3). Lubricate the bushing and bushing housing with Motorcraft® Silicone brake caliper grease. (Figures 10-11)

Figure 10



Figure 11



(4). Use an appropriate diameter socket, such as a 13 mm 3/8 drive chrome deep socket, to push the bushing into the caliper bushing housing. (Figures 12-14)

Figure 12

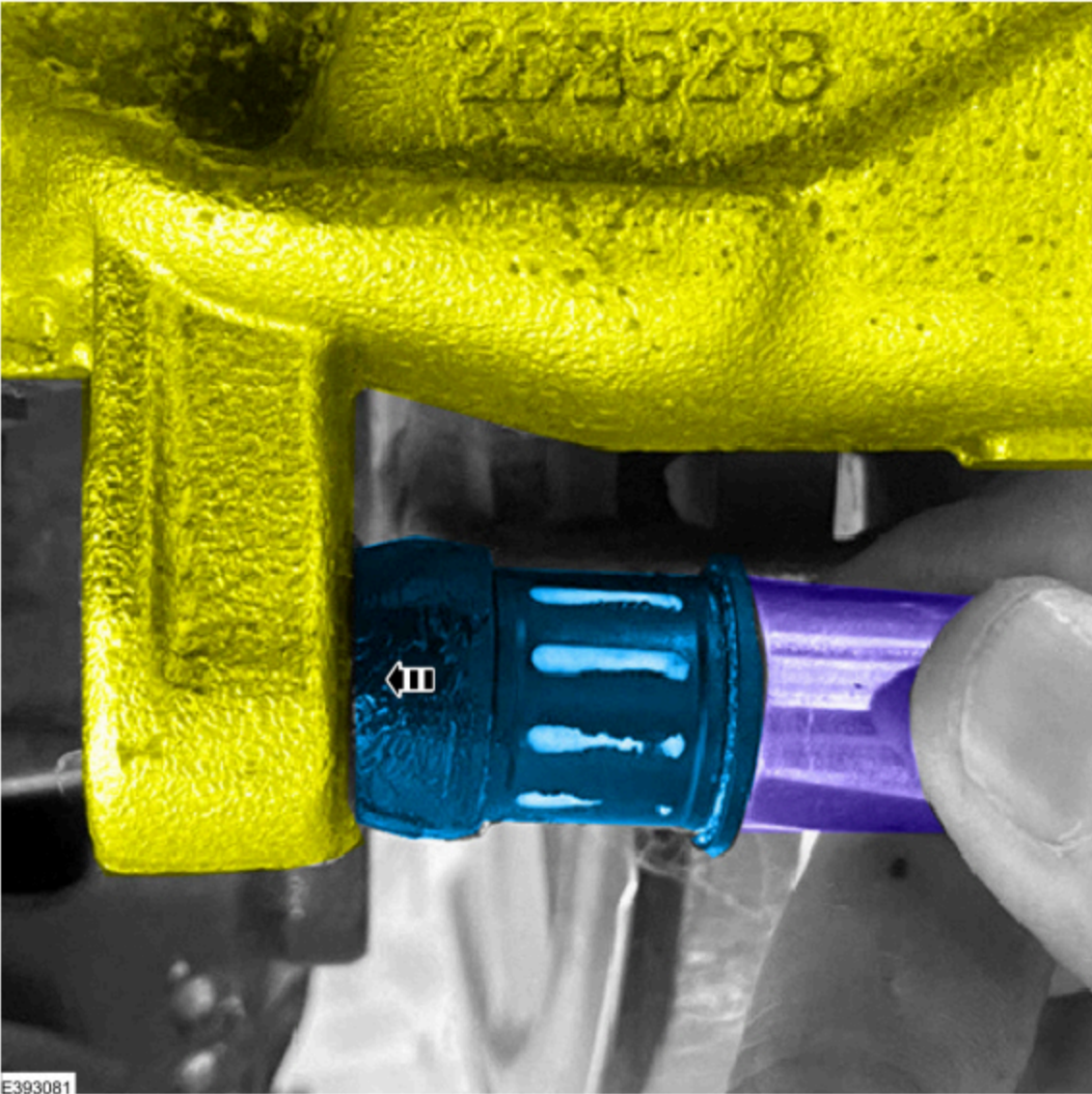

Figure 13

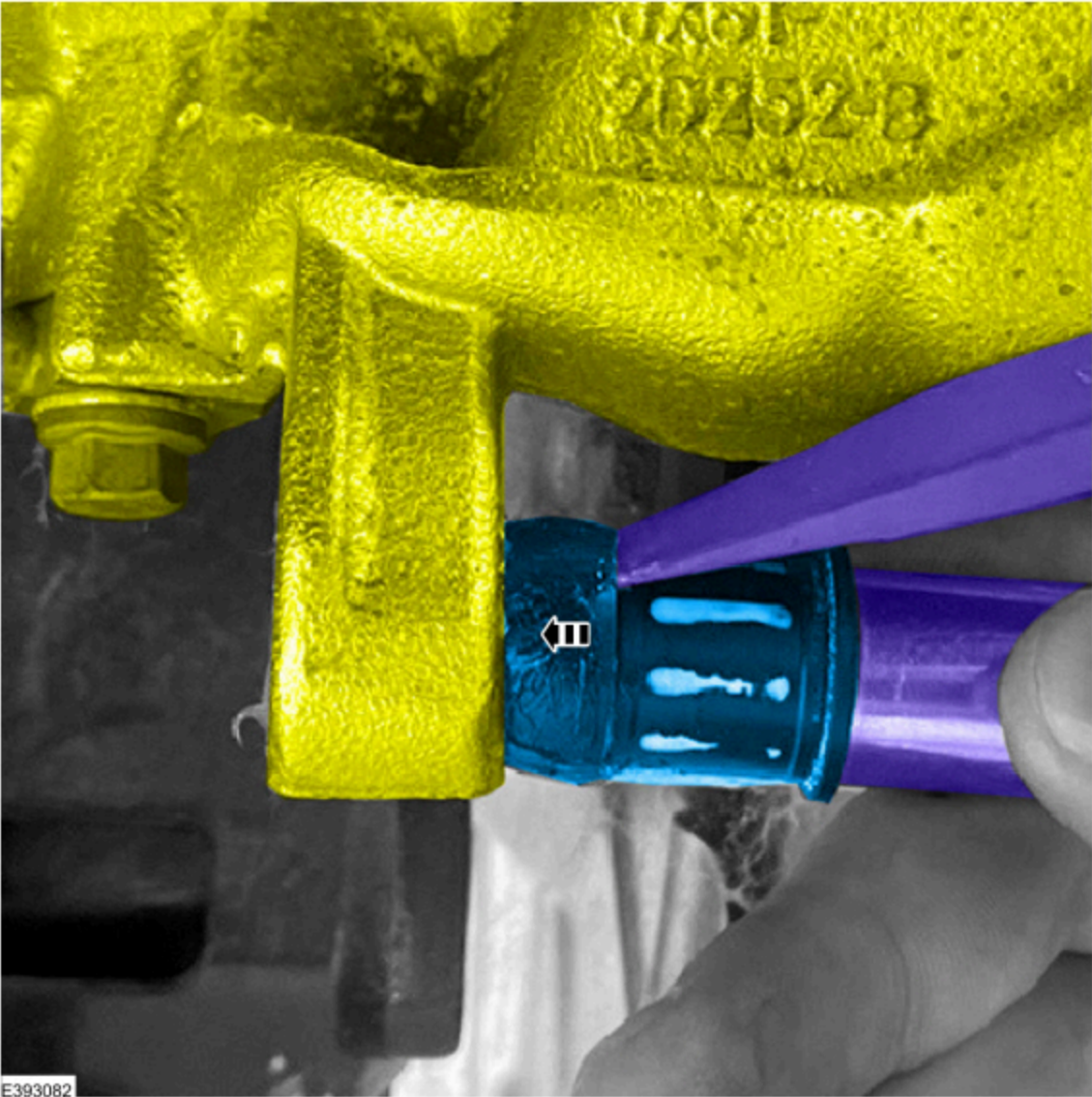
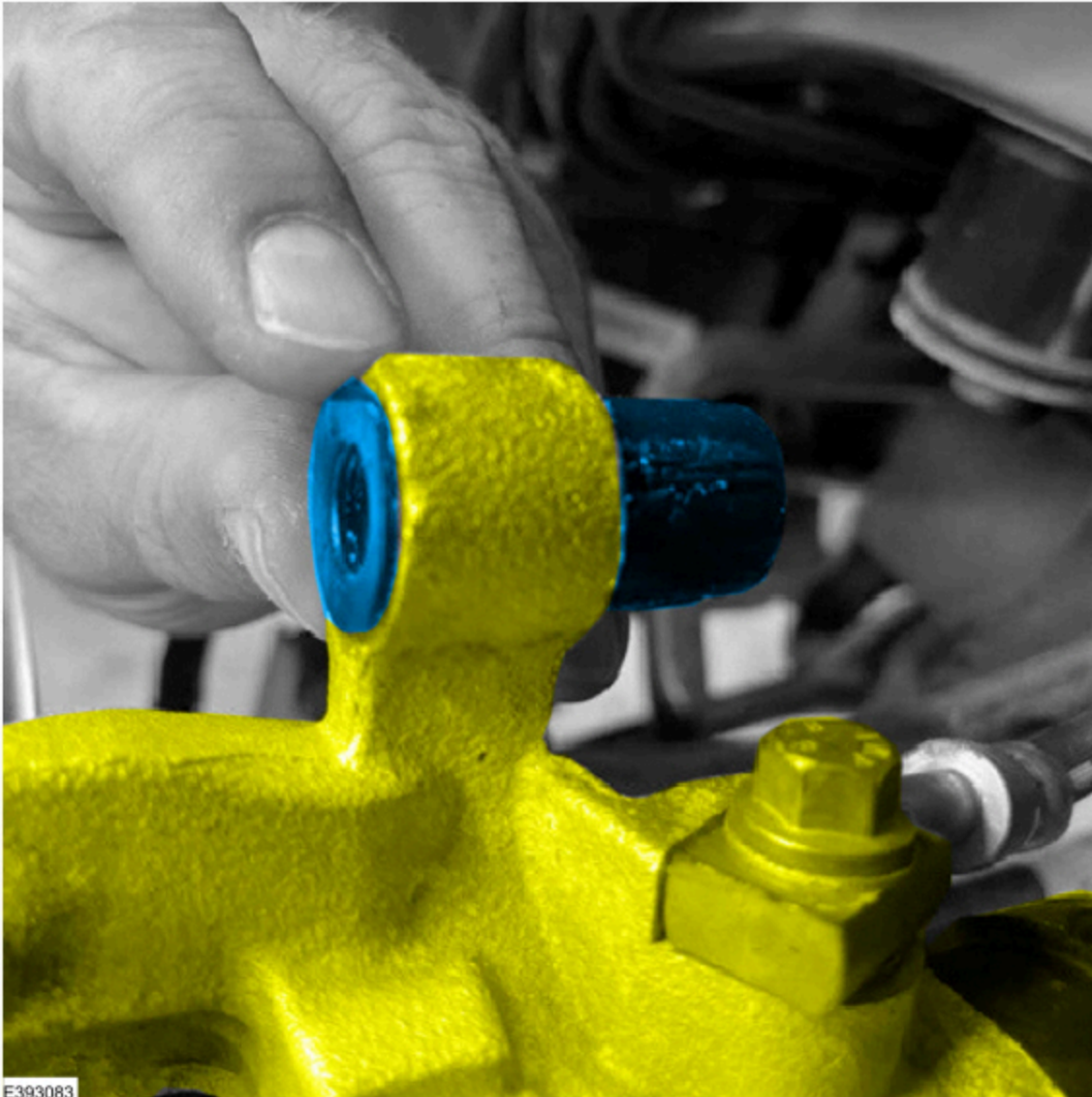

Figure 14



**NOTE: Use a plastic trim tool to help guide the bushing into the housing.**

**9.** Position the rear caliper in place and reinstall the guide pin (Figure 15)

Figure 15

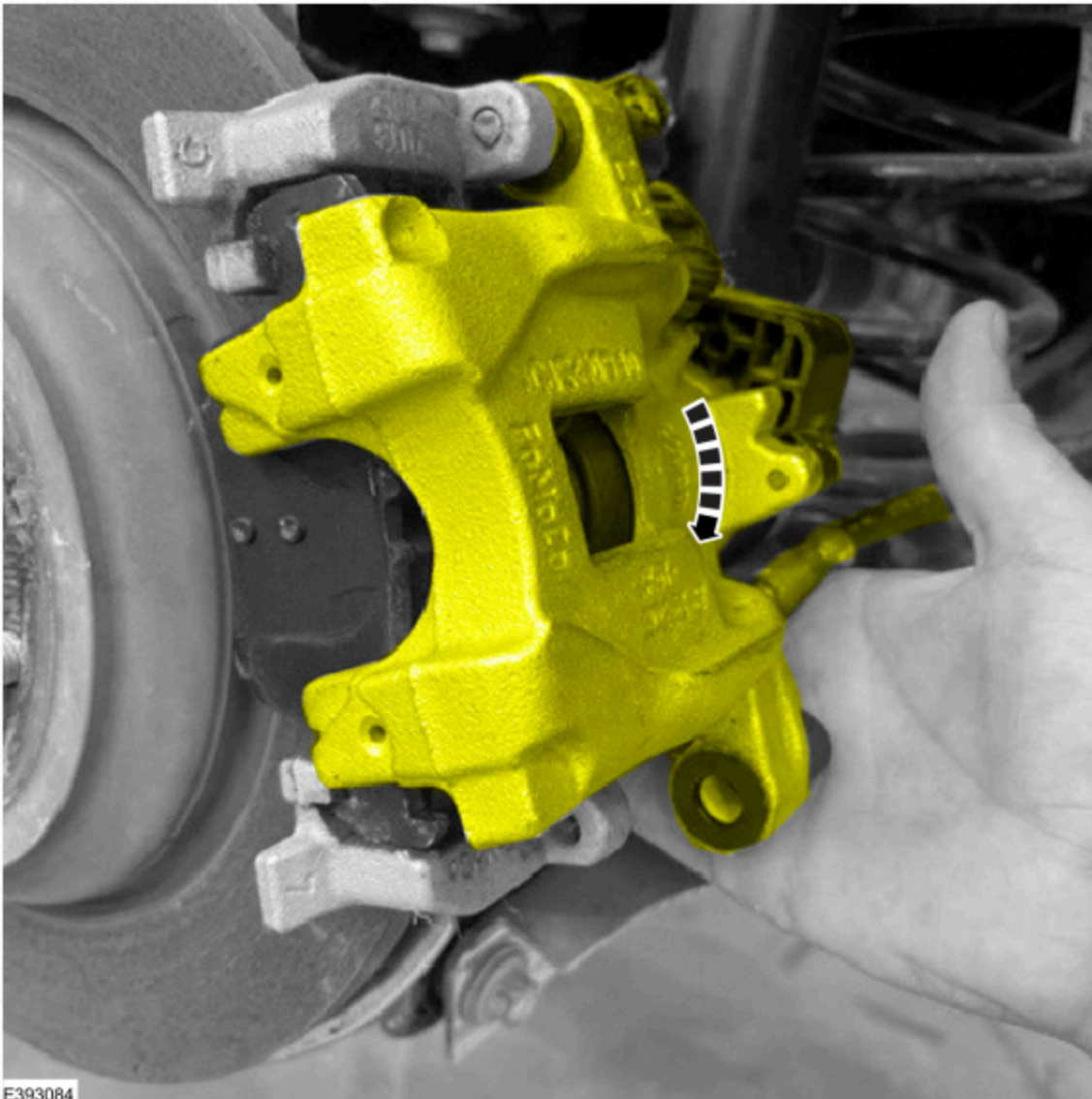

(1). Tighten the lower pin enough to rotate the caliper

**10.** Remove and discard the upper brake caliper guide pin cap and guide pin beside the bleeder. (Figure 16)

Figure 16

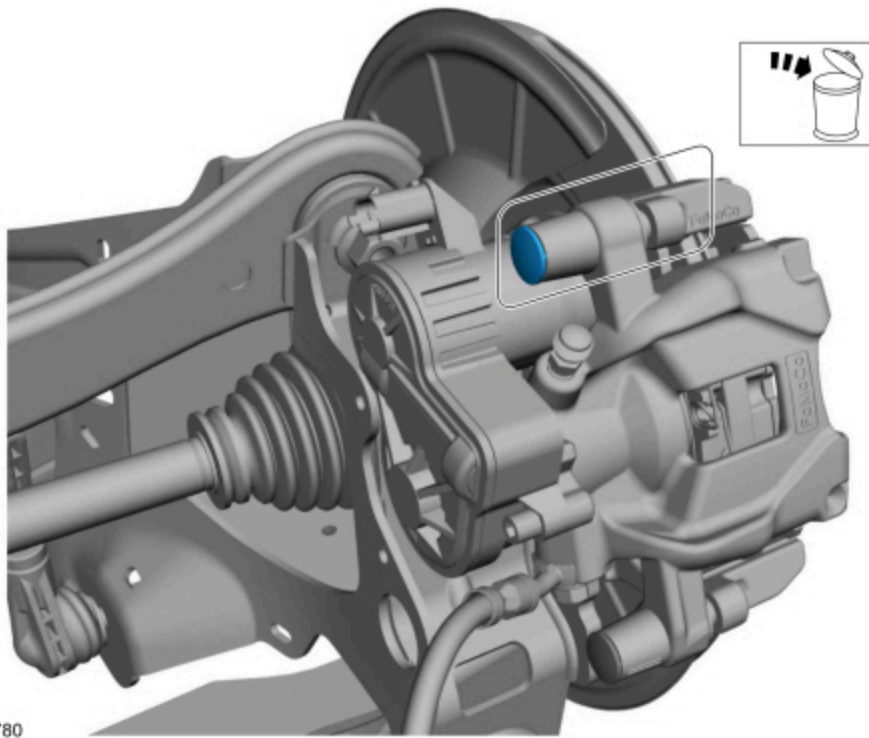

11. Rotate the caliper downwards to access to the bushing housing.
12. Using 6 inch slip joint pliers, remove and discard the standard bushing located beside the bleeder.
13. Install a new standard bushing.
  - (1). Use a ½ inch drum sander bit to clean the caliper bushing housing.
  - (2). Use Motorcraft® Metal Brake Parts Cleaner to remove any brake dust from the bushing housing.
  - (3). Lubricate the bushing and bushing housing with Motorcraft® Silicone brake caliper grease.
  - (4). Use an appropriate diameter socket, such as a 13 mm 3/8 drive chrome deep socket, to push the bushing into the caliper bushing housing.

**NOTE: Use a plastic trim tool to help guide the bushing into the housing.**

14. Remove the lower guide pin and position the brake caliper aside.
15. Remove and discard the rear brake caliper anchor plate bolts and position the rear anchor plate aside.
16. Measure the thickness of the rear brake discs. Refer to the WSM, Section 206-00 Brake System > General Information > Specifications. Are one or both rear brake discs below the minimum specification?
  - (1). Yes - remove and discard both rear brake discs. Refer to the WSM, Section 206-04 Rear Disc Brake > Removal and Installation. Proceed to Step 17.
  - (2). No - machine both rear brake discs. Refer to the WSM, Section 206-00 Brake System > General Information. Proceed to Step 19.
17. Clean the mating surfaces of the rear brake disc and wheel hub.
18. Install new rear brake discs.
19. Reinstall the rear brake caliper anchor plate.
  - (1). Install new brake caliper anchor plate bolts and tighten to 63 Nm (46 lb-ft).
20. Remove and discard the brake pads. Refer to the WSM, Section 206-04 Rear Disc Brake > Removal and Installation
21. Compress the brake caliper piston until the piston bottoms out in the brake caliper bore. (Figure 17)

Figure 17



E203783

**22.** Use Motorcraft® Metal Brake Parts Cleaner, wire brush and an abrasive pad (super fine grade) to clean the brake pad to anchor plate contact points. (Figure 18)

Figure 18

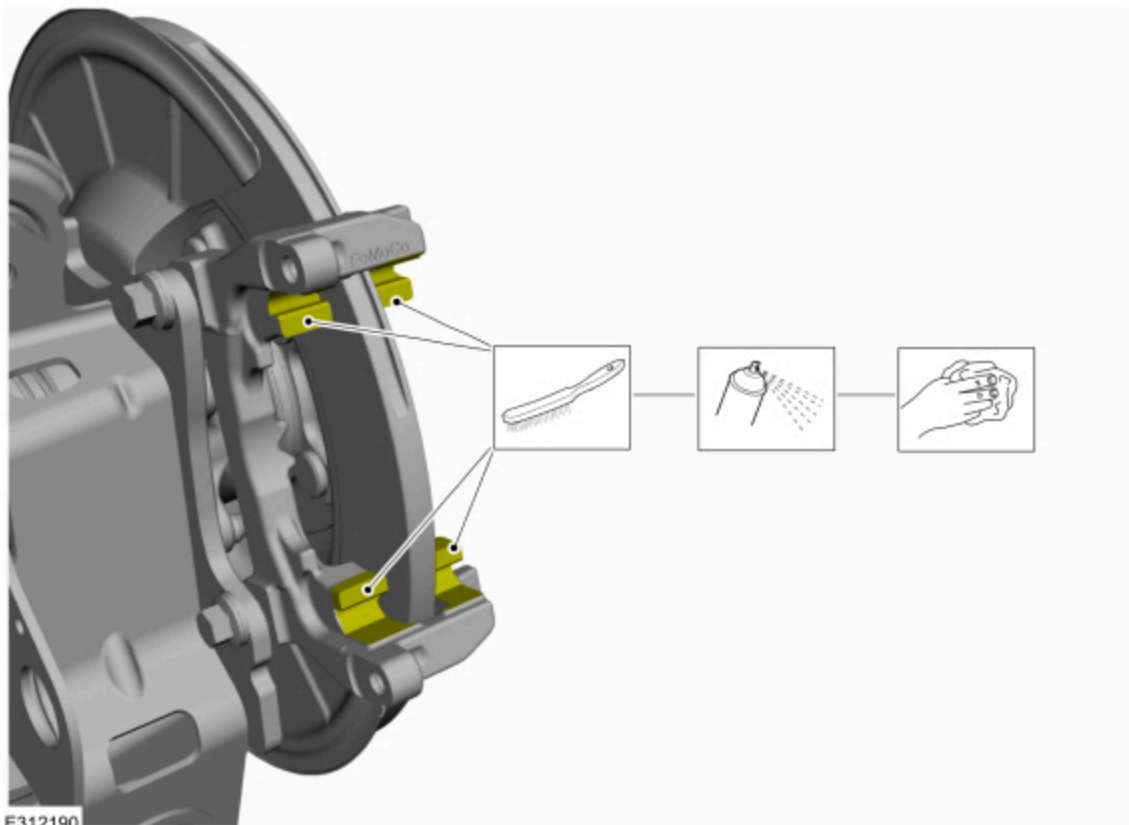

E312190

**23.** Use Motorcraft® Metal Brake Parts Cleaner and an abrasive pad (super fine grade) to clean the brake caliper. (Figure 19-20)

Figure 19

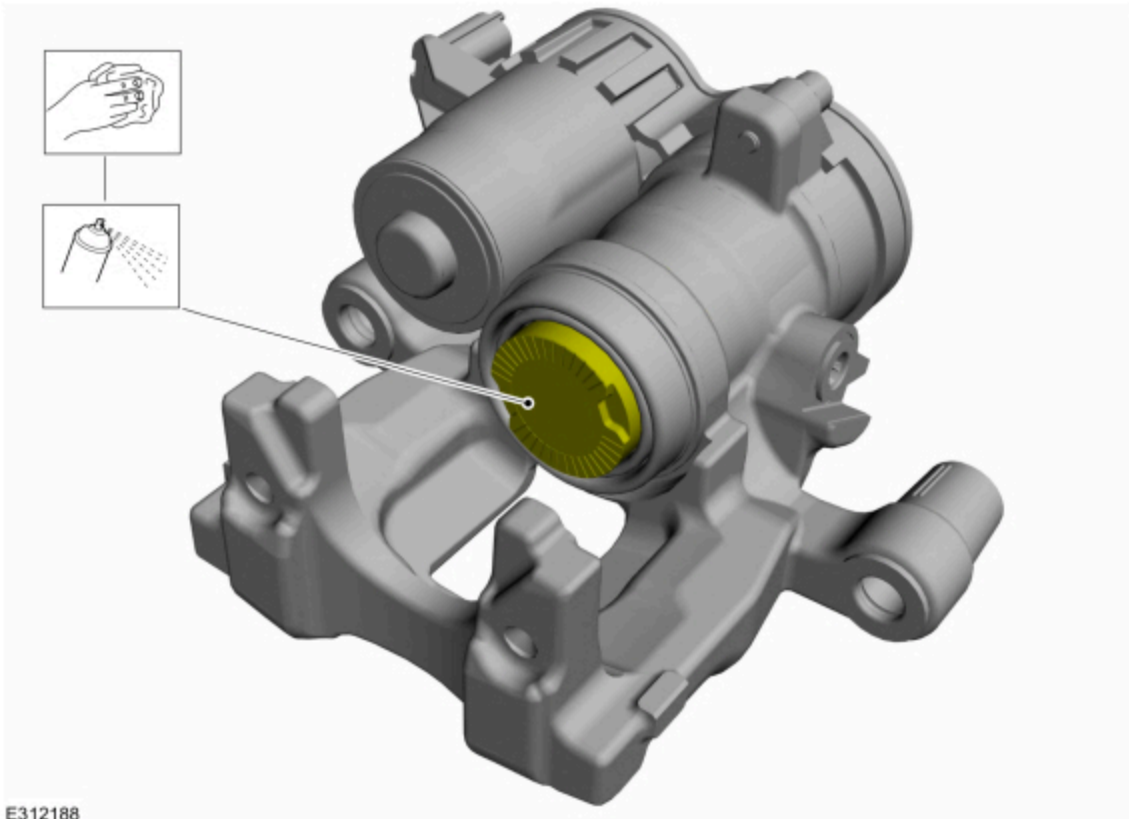

E312188

Figure 20

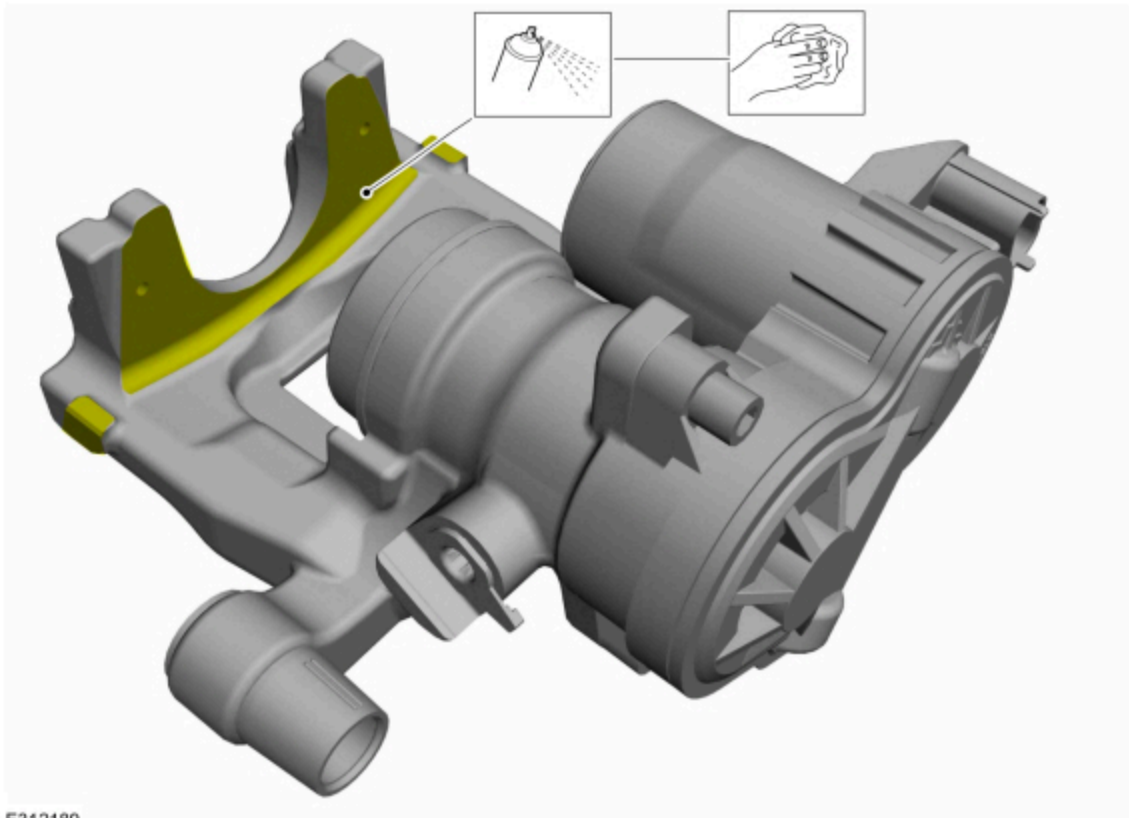

E312189

24. Use compressed air to completely dry the contact areas.

25. Apply Motorcraft® Silicone brake caliper grease to the anchor plate contact points. (Figure 21)

Figure 21

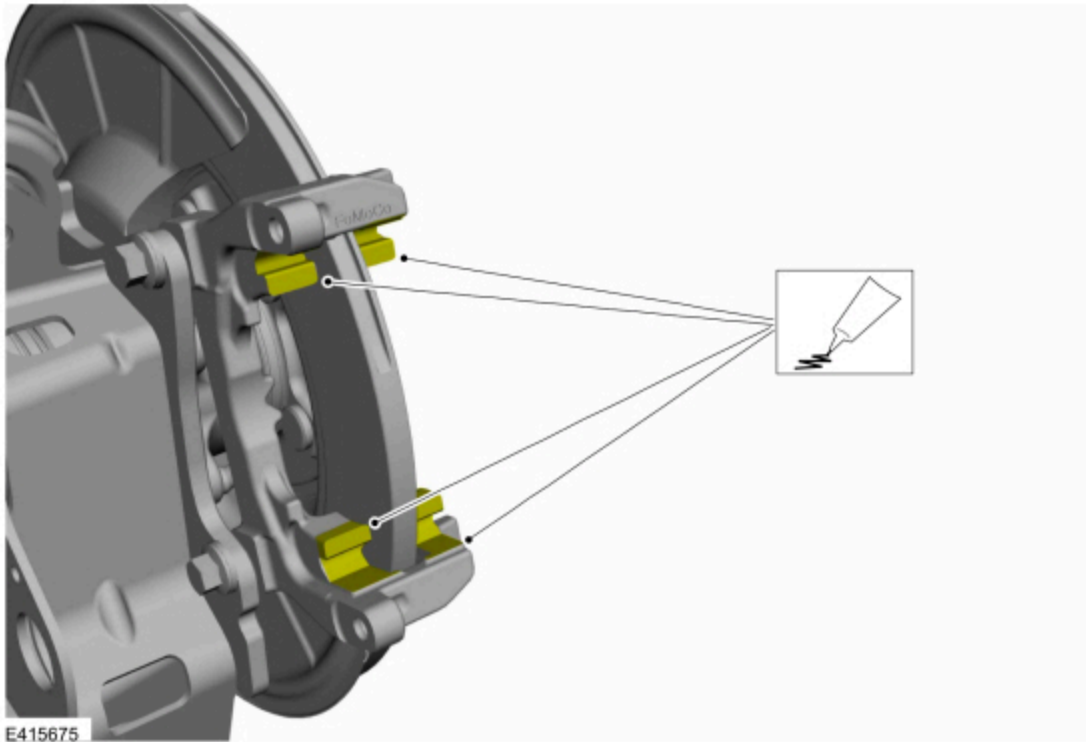

**26.** Install new brake pads in the caliper.

**27.** Position the brake pad clips. (Figure 22)

Figure 22

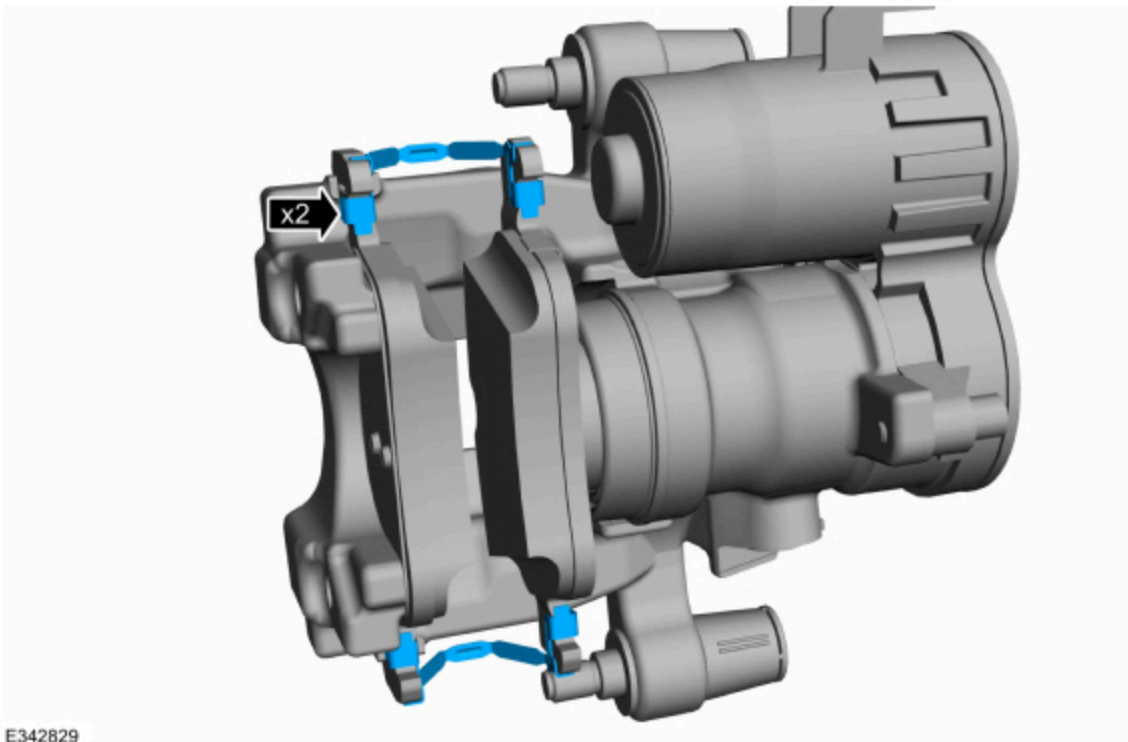

**28.** Position the rear caliper in place and install new guide pins.

(1). Lubricate the guide pins with Motorcraft® Silicone brake caliper grease.

(2). Tighten both guide pins to 28 Nm (21 lb-ft).

**29.** Install the new guide pin caps.

**30.** Reinstall the caliper spring.

**NOTE: Inspect the brake caliper spring for any damage. If the brake caliper spring is bent or damaged, install a new brake caliper spring.**

31. To assemble the vehicle, reverse the removal procedure.
32. Deactivate the brake service mode. Refer to the WSM, Section 206-00 Brake System > General Information > General Procedures.
33. Apply the brake pedal several times to verify correct brake system operation.

## **Procedure B: Installation Of Brake Pads And Clips - Vehicles Equipped With Reinforced Bushings**

**NOTE: Perform the following procedure on both rear calipers.**

1. Activate the brake service mode. Refer to the WSM, Section 206-00 Brake System > General Information > General Procedures.
2. Remove the wheel and tire. Refer to the WSM, Section 204-04A Wheels and Tires > Removal and Installation.
3. Remove the brake caliper spring.
4. Disconnect the parking brake electrical connector.
5. Remove both guide pin caps. (Figure 23)

Figure 23

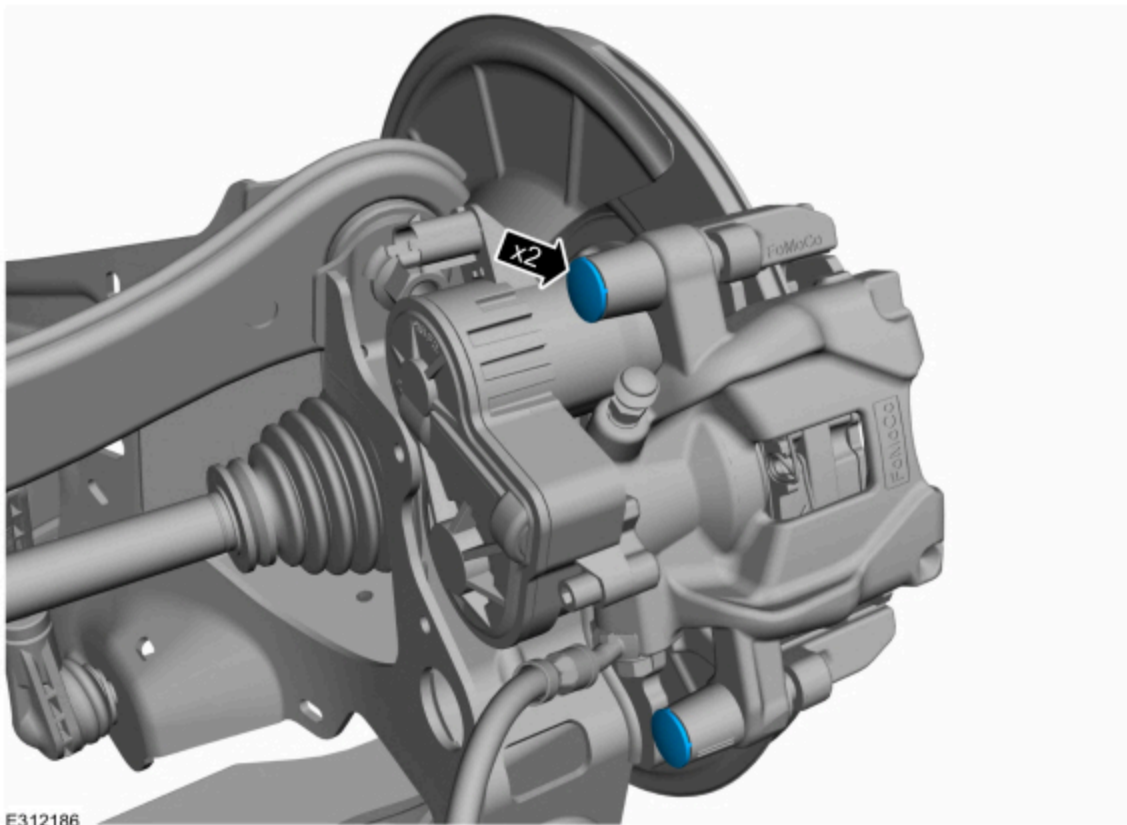

6. Remove both guide pins and position the brake caliper aside. (Figure 24)

Figure 24

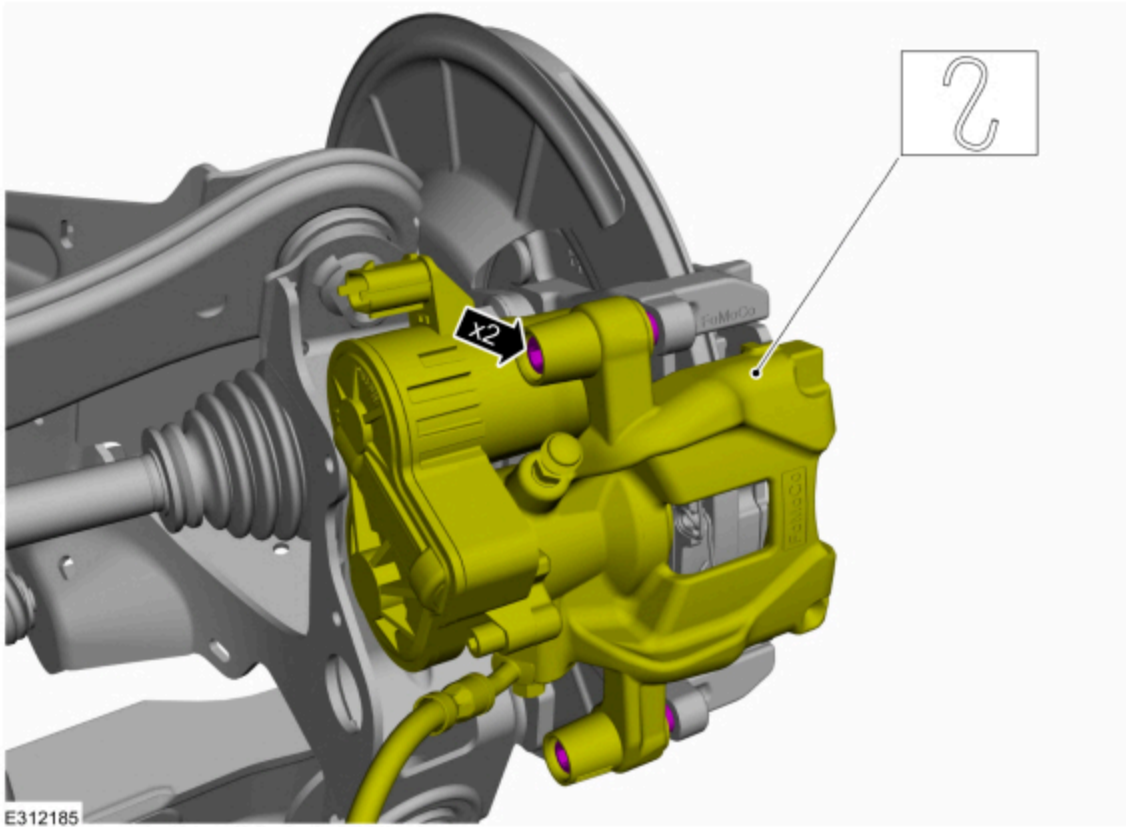

7. Remove and discard the rear caliper anchor plate bolts and position the rear anchor plate aside.
8. Measure the thickness of the rear brake discs. Refer to the WSM, Section 206-00 Brake System > General Information > Specifications. Are one or both rear brake discs below the minimum specification?
  - (1). Yes - remove and discard both rear brake discs. Refer to the WSM, Section 206-04 Rear Disc Brake > Removal and Installation. Proceed to Step 9.
  - (2). No - machine both rear brake discs. Refer to the WSM, Section 206-00 Brake System > General Information. Proceed to Step 11.
9. Clean the mating surfaces of the rear brake disc and wheel hub.
10. Install new rear brake discs.
11. Reinstall the rear brake caliper anchor plate.
  - (1). Install the new brake caliper anchor plate bolts and tighten to 63 Nm (46lb-ft)
12. Remove and discard the brake pads. (Figure 25)

Figure 25

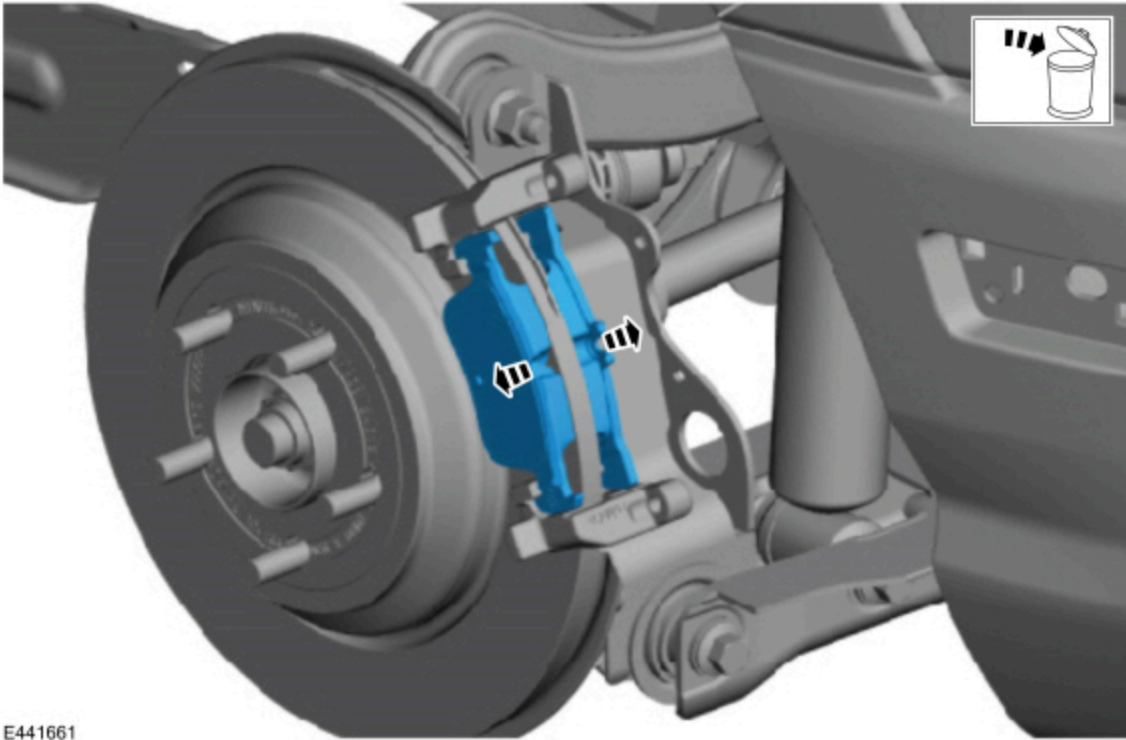

E441661

13. Compress the brake caliper piston until the piston bottoms out in the brake caliper bore. (Figure 26)  
Figure 26



E203783

14. Use Motorcraft® Metal Brake Parts Cleaner, wire brush and an abrasive pad (super fine grade) to clean the brake pad to anchor plate contact points. (Figures 27)

Figure 27

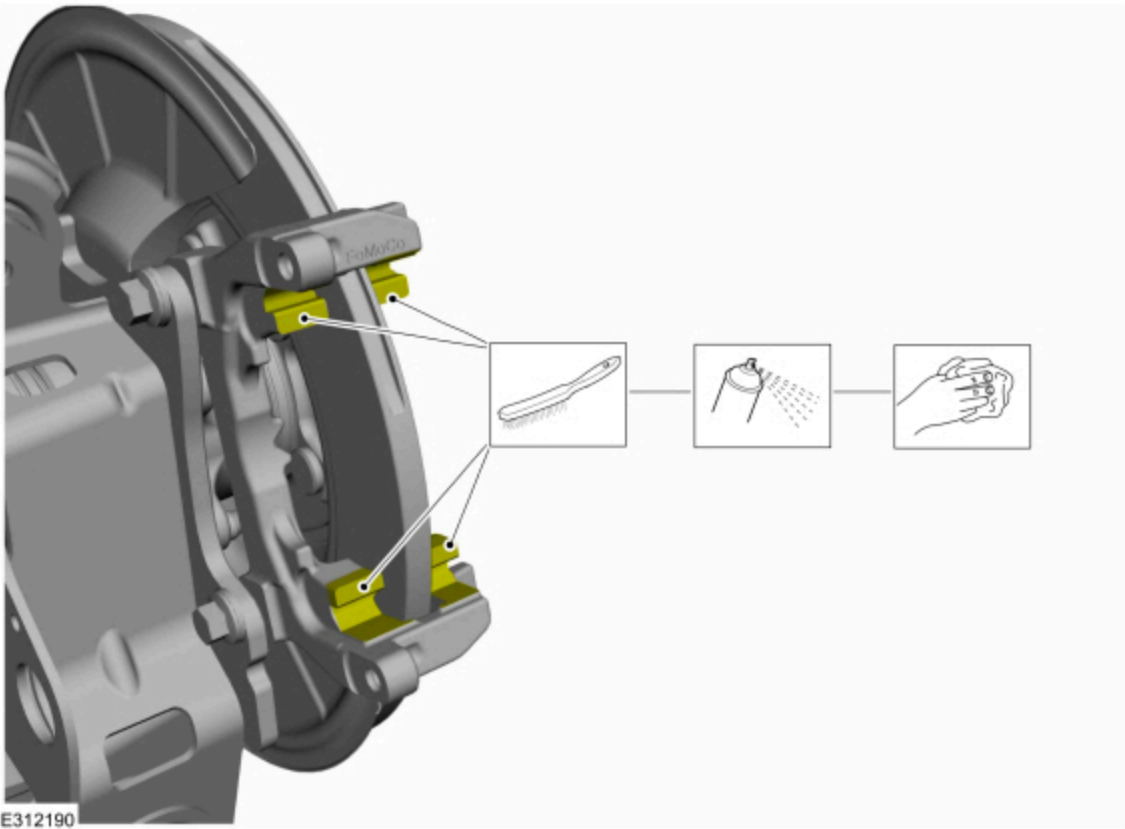

15. Use Motorcraft® Metal Brake Parts Cleaner and an abrasive pad (super fine grade) to clean the brake caliper. (Figure 28-29)

Figure 28

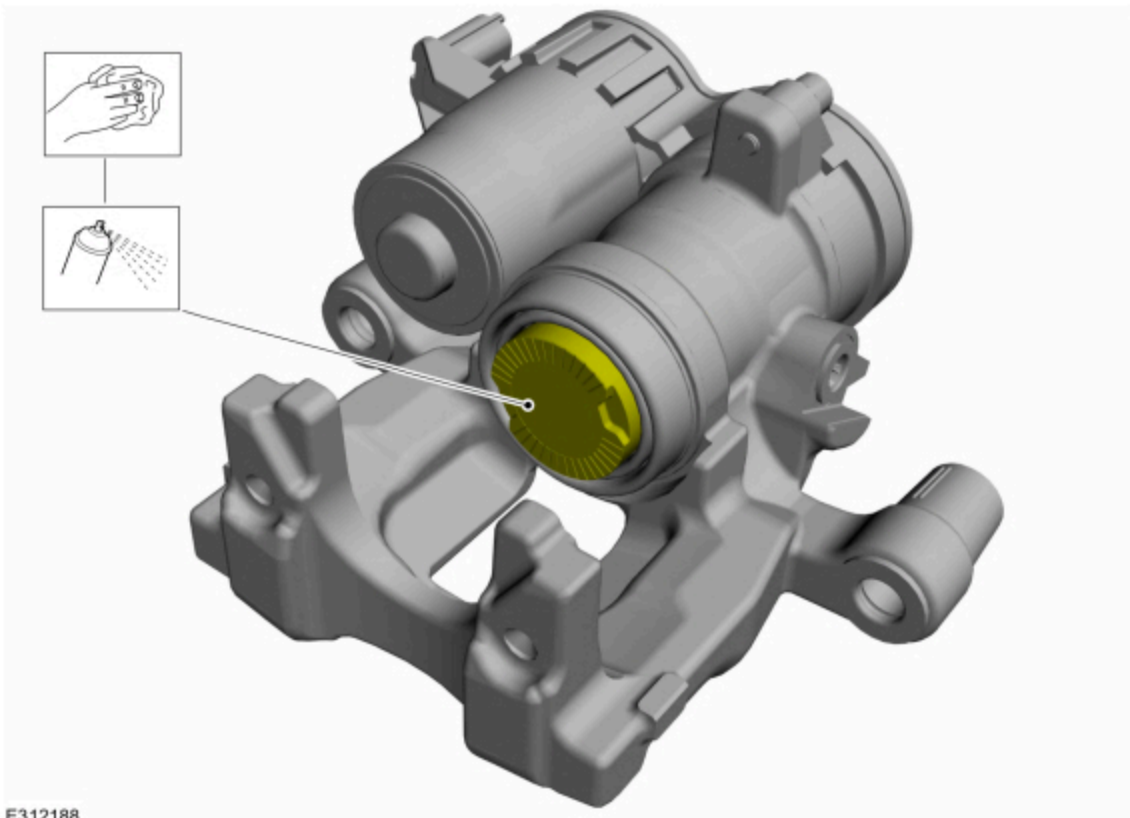
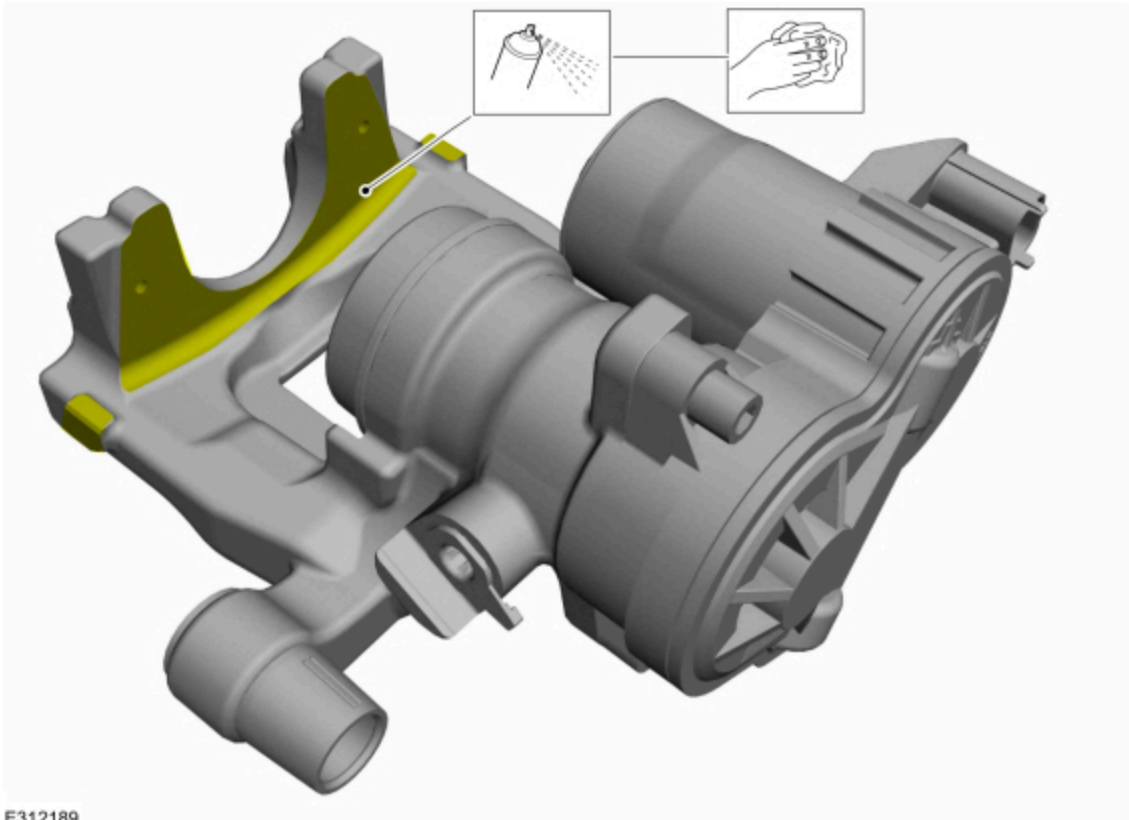

Figure 29



E312189

**16.** Use compressed air to completely dry the contact areas.

**17.** Apply Motorcraft® Silicone brake caliper grease to the anchor plate contact points (Figure 30)

Figure 30

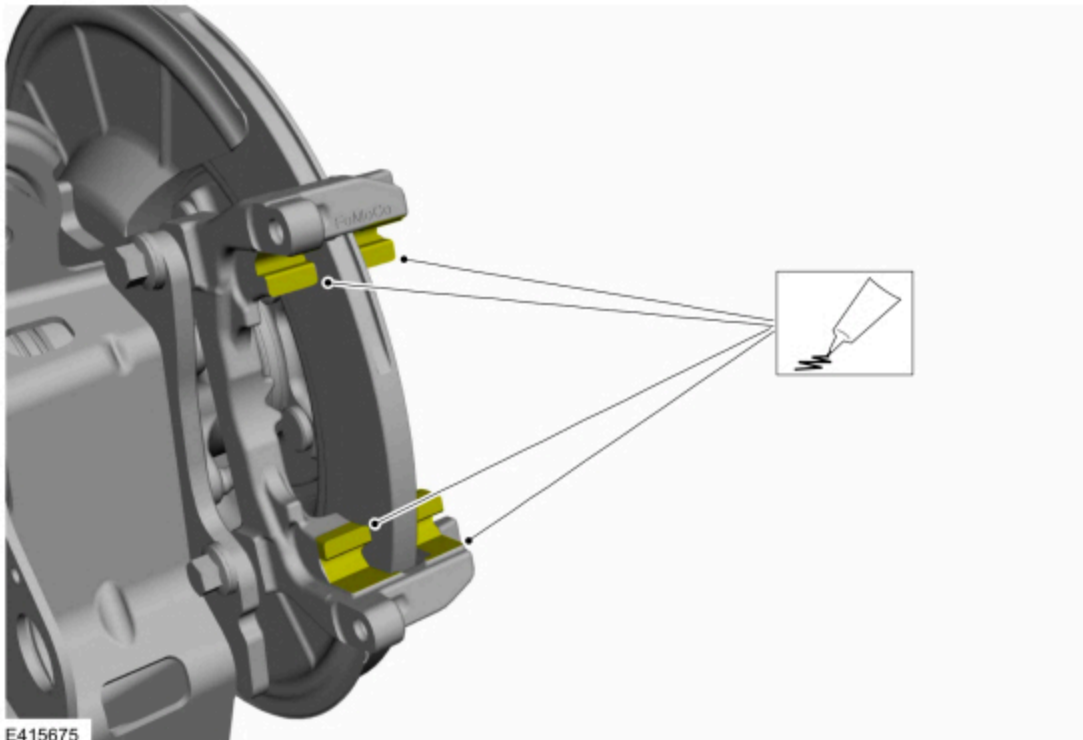

E415675

**18.** Install new brake pads in the caliper.

**19.** Position the brake pad clips. (Figure 31)

Figure 31

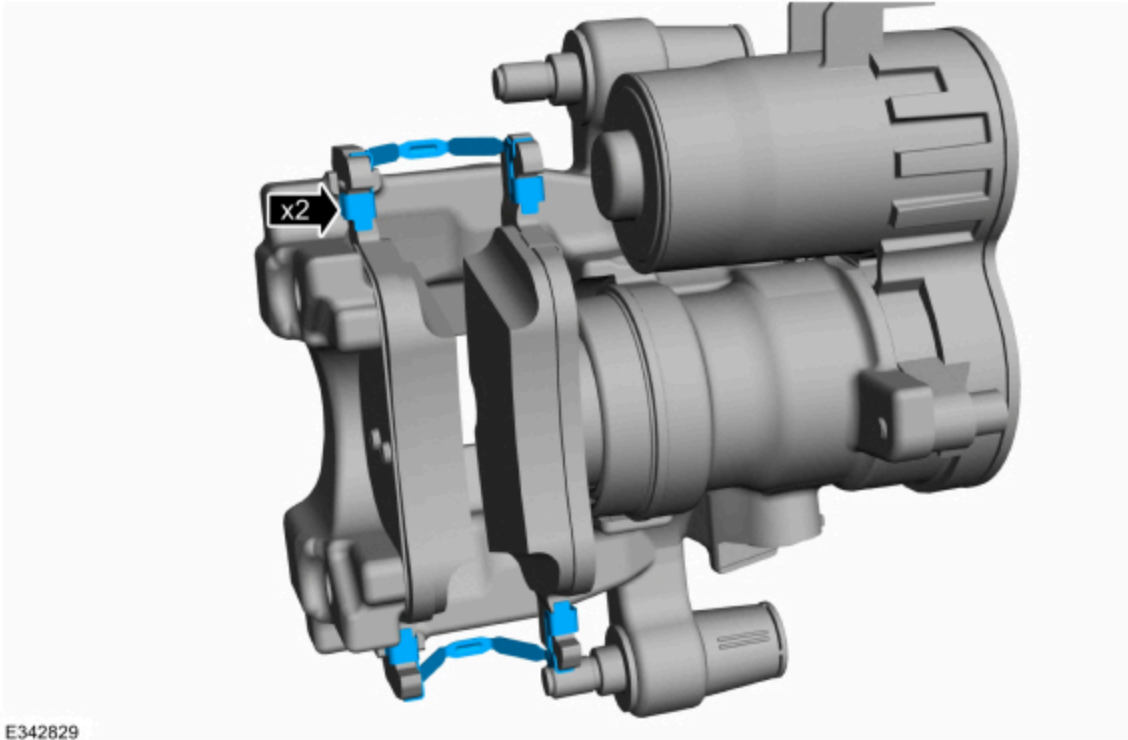

**20.** Position the rear caliper in place and reinstall guide pins.

- (1). Use Motorcraft® Metal Brake Parts Cleaner and clean the guide pins.
- (2). Lubricate the guide pins with Motorcraft® Silicone brake caliper grease.
- (3). Tighten both guide pins to 28 Nm (21 lb-ft).

**21.** Reinstall the guide pin caps.

**22.** Reinstall the brake caliper spring.

**NOTE: Inspect the brake caliper spring for any damage. If the brake caliper spring is bent or damaged, install a new brake caliper spring.**

**23.** To assemble the vehicle, reverse the removal procedure.

**24.** Deactivate the brake service mode. Refer to the [WSM](#), Section 206-00 Brake System > General Information > General Procedures.

**25.** Apply the brake pedal several times to verify correct brake system operation.

---

© 2025 Ford Motor Company

All rights reserved.

NOTE: The information in Technical Service Bulletins is intended for use by trained, professional technicians with the knowledge, tools, and equipment to do the job properly and safely. It informs these technicians of conditions that may occur on some vehicles, or provides information that could assist in proper vehicle service. The procedures should not be performed by "do-it-yourselfers". Do not assume that a condition described affects your car or truck. Contact a Ford or Lincoln dealership to determine whether the Bulletin applies to your vehicle. Warranty Policy and Extended Service Plan documentation determine Warranty and/or Extended Service Plan coverage unless stated otherwise in the TSB article. The information in this Technical Service Bulletin (TSB) was current at the time of printing. Ford Motor Company reserves the right to supersede this information with updates. The most recent information is available through Ford Motor Company's on-line technical resources.